



Windows Internals

Part 2

7

SEVENTH
EDITION



Andrea Allievi
Alex Ionescu
Mark E. Russinovich
David A. Solomon

Professional



Windows Internals

Seventh Edition

Part 2

Andrea Allievi
Alex Ionescu
Mark E. Russinovich
David A. Solomon

© WINDOWS INTERNALS, SEVENTH EDITION, PART 2

Published with the authorization of Microsoft Corporation by:
Pearson Education, Inc.

Copyright © 2022 by Pearson Education, Inc.

All rights reserved. This publication is protected by copyright, and permission must be obtained from the publisher prior to any prohibited reproduction, storage in a retrieval system, or transmission in any form or by any means, electronic, mechanical, photocopying, recording, or likewise. For information regarding permissions, request forms, and the appropriate contacts within the Pearson Education Global Rights & Permissions Department, please visit www.pearson.com/permissions.

No patent liability is assumed with respect to the use of the information contained herein. Although every precaution has been taken in the preparation of this book, the publisher and author assume no responsibility for errors or omissions. Nor is any liability assumed for damages resulting from the use of the information contained herein.

ISBN-13: 978-0-13-546240-9

ISBN-10: 0-13-546240-1

Library of Congress Control Number: 2021939878

ScoutAutomatedPrintCode

TRADEMARKS

Microsoft and the trademarks listed at <http://www.microsoft.com> on the "Trademarks" webpage are trademarks of the Microsoft group of companies. All other marks are property of their respective owners.

WARNING AND DISCLAIMER

Every effort has been made to make this book as complete and as accurate as possible, but no warranty or fitness is implied. The information provided is on an "as is" basis. The author, the publisher, and Microsoft Corporation shall have neither liability nor responsibility to any person or entity with respect to any loss or damages arising from the information contained in this book or from the use of the programs accompanying it.

SPECIAL SALES

For information about buying this title in bulk quantities, or for special sales opportunities (which may include electronic versions; custom cover designs; and content particular to your business, training goals, marketing focus, or branding interests), please contact our corporate sales department at corp-sales@pearsoned.com or (800) 382-3419.

For government sales inquiries,
please contact governmentsales@pearsoned.com.

For questions about sales outside the U.S.,
please contact intlcs@pearson.com.

Editor-in-Chief: Brett Bartow

Development Editor: Mark Renfrow

Managing Editor: Sandra Schroeder

Senior Project Editor: Tracey Croom

Executive Editor: Loretta Yates

Production Editor: Dan Foster

Copy Editor: Charlotte Kughen

Indexer: Valerie Haynes Perry

Proofreader: Dan Foster

Technical Editor: Christophe Nasarre

Editorial Assistant: Cindy Teeters

Cover Designer: Twist Creative, Seattle

Compositor: Danielle Foster

Graphics: Vived Graphics

To my parents, Gabriella and Danilo, and to my brother, Luca, who all always believed in me and pushed me in following my dreams.

—ANDREA ALLIEVI

To my wife and daughter, who never give up on me and are a constant source of love and warmth. To my parents, for inspiring me to chase my dreams and making the sacrifices that gave me opportunities.

—ALEX IONESCU

Contents at a Glance

	<i>About the Authors</i>	<i>xviii</i>
	<i>Foreword</i>	<i>xx</i>
	<i>Introduction</i>	<i>xxiii</i>
CHAPTER 8	System mechanisms	1
CHAPTER 9	Virtualization technologies	267
CHAPTER 10	Management, diagnostics, and tracing	391
CHAPTER 11	Caching and file systems	565
CHAPTER 12	Startup and shutdown	777
	<i>Contents of Windows Internals, Seventh Edition, Part 1</i>	<i>851</i>
	<i>Index</i>	<i>861</i>

Contents

<i>About the Authors</i>	<i>xviii</i>
<i>Foreword</i>	<i>xx</i>
<i>Introduction</i>	<i>xxiii</i>

Chapter 8	System mechanisms	1
Processor execution model		2
Segmentation		2
Task state segments		6
Hardware side-channel vulnerabilities		9
Out-of-order execution		10
The CPU branch predictor		11
The CPU cache(s)		12
Side-channel attacks		13
Side-channel mitigations in Windows		18
KVA Shadow		18
Hardware indirect branch controls (IBRS, IBPB, STIBP, SSBD)		21
Retpoline and import optimization		23
STIBP pairing		26
Trap dispatching		30
Interrupt dispatching		32
Line-based versus message signaled-based interrupts		50
Timer processing		66
System worker threads		81
Exception dispatching		85
System service handling		91
WoW64 (Windows-on-Windows)		104
The WoW64 core		106
File system redirection		109
Registry redirection		110
X86 simulation on AMD64 platforms		111
ARM		113

Memory models.....	114
ARM32 simulation on ARM64 platforms.....	115
X86 simulation on ARM64 platforms.....	115
Object Manager.....	125
Executive objects.....	127
Object structure.....	131
Synchronization.....	170
High-IRQL synchronization.....	172
Low-IRQL synchronization.....	177
Advanced local procedure call.....	209
Connection model.....	210
Message model.....	212
Asynchronous operation.....	214
Views, regions, and sections.....	215
Attributes.....	216
Blobs, handles, and resources.....	217
Handle passing.....	218
Security.....	219
Performance.....	220
Power management.....	221
ALPC direct event attribute.....	222
Debugging and tracing.....	222
Windows Notification Facility.....	224
WNF features.....	225
WNF users.....	226
WNF state names and storage.....	233
WNF event aggregation.....	237
User-mode debugging.....	239
Kernel support.....	239
Native support.....	240
Windows subsystem support.....	242
Packaged applications.....	243
UWP applications.....	245
Centennial applications.....	246

The Host Activity Manager	249
The State Repository	251
The Dependency Mini Repository	255
Background tasks and the Broker Infrastructure	256
Packaged applications setup and startup	258
Package activation	259
Package registration	265
Conclusion	266

Chapter 9 Virtualization technologies 267

The Windows hypervisor	267
Partitions, processes, and threads	269
The hypervisor startup	274
The hypervisor memory manager	279
Hyper-V schedulers	287
Hypercalls and the hypervisor TLFS	299
Intercepts	300
The synthetic interrupt controller (SynIC)	301
The Windows hypervisor platform API and EXO partitions	304
Nested virtualization	307
The Windows hypervisor on ARM64	313
The virtualization stack	315
Virtual machine manager service and worker processes	315
The VID driver and the virtualization stack memory manager	317
The birth of a Virtual Machine (VM)	318
VMBus	323
Virtual hardware support	329
VA-backed virtual machines	336
Virtualization-based security (VBS)	340
Virtual trust levels (VTLs) and Virtual Secure Mode (VSM)	340
Services provided by the VSM and requirements	342
The Secure Kernel	345
Virtual interrupts	345
Secure intercepts	348

VSM system calls	349
Secure threads and scheduling	356
The Hypervisor Enforced Code Integrity	358
UEFI runtime virtualization	358
VSM startup	360
The Secure Kernel memory manager	363
Hot patching	368
Isolated User Mode	371
Trustlets creation	372
Secure devices	376
VBS-based enclaves	378
System Guard runtime attestation	386
Conclusion	390

Chapter 10 Management, diagnostics, and tracing **391**

The registry	391
Viewing and changing the registry	391
Registry usage	392
Registry data types	393
Registry logical structure	394
Application hives	402
Transactional Registry (TxR)	403
Monitoring registry activity	404
Process Monitor internals	405
Registry internals	406
Hive reorganization	414
The registry namespace and operation	415
Stable storage	418
Registry filtering	422
Registry virtualization	422
Registry optimizations	425
Windows services	426
Service applications	426
Service accounts	433
The Service Control Manager (SCM)	446

Service control programs	450
Autostart services startup	451
Delayed autostart services	457
Triggered-start services	458
Startup errors	459
Accepting the boot and last known good	460
Service failures	462
Service shutdown	464
Shared service processes	465
Service tags	468
User services	469
Packaged services	473
Protected services	474
Task scheduling and UBPM	475
The Task Scheduler	476
Unified Background Process Manager (UBPM)	481
Task Scheduler COM interfaces	486
Windows Management Instrumentation	486
WMI architecture	487
WMI providers	488
The Common Information Model and the Managed Object Format Language	489
Class association	493
WMI implementation	496
WMI security	498
Event Tracing for Windows (ETW)	499
ETW initialization	501
ETW sessions	502
ETW providers	506
Providing events	509
ETW Logger thread	511
Consuming events	512
System loggers	516
ETW security	522

Dynamic tracing (DTrace)	525
Internal architecture	528
DTrace type library	534
Windows Error Reporting (WER).....	535
User applications crashes	537
Kernel-mode (system) crashes.....	543
Process hang detection	551
Global flags	554
Kernel shims	557
Shim engine initialization	557
The shim database	559
Driver shims.....	560
Device shims	564
Conclusion	564

Chapter 11 Caching and file systems 565

Terminology	565
Key features of the cache manager	566
Single, centralized system cache.....	567
The memory manager	567
Cache coherency	568
Virtual block caching	569
Stream-based caching	569
Recoverable file system support	570
NTFS MFT working set enhancements	571
Memory partitions support	571
Cache virtual memory management.....	572
Cache size.....	574
Cache virtual size	574
Cache working set size.....	574
Cache physical size	574
Cache data structures.....	576
Systemwide cache data structures	576
Per-file cache data structures.....	579

File system interfaces	582
Copying to and from the cache.....	584
Caching with the mapping and pinning interfaces.....	584
Caching with the direct memory access interfaces.....	584
Fast I/O	585
Read-ahead and write-behind	586
Intelligent read-ahead	587
Read-ahead enhancements	588
Write-back caching and lazy writing.....	589
Disabling lazy writing for a file	595
Forcing the cache to write through to disk	595
Flushing mapped files.....	595
Write throttling.....	596
System threads	597
Aggressive write behind and low-priority lazy writes	598
Dynamic memory	599
Cache manager disk I/O accounting	600
File systems	602
Windows file system formats	602
CDFS.....	602
UDF.....	603
FAT12, FAT16, and FAT32	603
exFAT	606
NTFS.....	606
ReFS	608
File system driver architecture.....	608
Local FSDs.....	608
Remote FSDs	610
File system operations	618
Explicit file I/O.....	619
Memory manager's modified and mapped page writer.....	622
Cache manager's lazy writer.....	622
Cache manager's read-ahead thread	622
Memory manager's page fault handler	623
File system filter drivers and minifilters.....	623

Filtering named pipes and mailslots	625
Controlling reparse point behavior	626
Process Monitor	627
The NT File System (NTFS)	628
High-end file system requirements	628
Recoverability	629
Security	629
Data redundancy and fault tolerance	629
Advanced features of NTFS	630
Multiple data streams	631
Unicode-based names	633
General indexing facility	633
Dynamic bad-cluster remapping	633
Hard links	634
Symbolic (soft) links and junctions	634
Compression and sparse files	637
Change logging	637
Per-user volume quotas	638
Link tracking	639
Encryption	640
POSIX-style delete semantics	641
Defragmentation	643
Dynamic partitioning	646
NTFS support for tiered volumes	647
NTFS file system driver	652
NTFS on-disk structure	654
Volumes	655
Clusters	655
Master file table	656
File record numbers	660
File records	661
File names	664
Tunneling	666
Resident and nonresident attributes	667
Data compression and sparse files	670

Compressing sparse data	671
Compressing nonsparse data.....	673
Sparse files	675
The change journal file.....	675
Indexing	679
Object IDs.....	681
Quota tracking	681
Consolidated security.....	682
Reparse points	684
Storage reserves and NTFS reservations.....	685
Transaction support	688
Isolation	689
Transactional APIs	690
On-disk implementation.....	691
Logging implementation	693
NTFS recovery support	694
Design	694
Metadata logging	695
Log file service	695
Log record types	697
Recovery.....	699
Analysis pass	700
Redo pass.....	701
Undo pass.....	701
NTFS bad-cluster recovery	703
Self-healing	706
Online check-disk and fast repair	707
Encrypted file system	710
Encrypting a file for the first time.....	713
The decryption process	715
Backing up encrypted files	716
Copying encrypted files.....	717
BitLocker encryption offload	717
Online encryption support.....	719

Direct Access (DAX) disks	720
DAX driver model	721
DAX volumes	722
Cached and noncached I/O in DAX volumes	723
Mapping of executable images	724
Block volumes	728
File system filter drivers and DAX	730
Flushing DAX mode I/Os	731
Large and huge pages support	732
Virtual PM disks and storages spaces support	736
Resilient File System (ReFS)	739
Minstore architecture	740
B+ tree physical layout	742
Allocators	743
Page table	745
Minstore I/O	746
ReFS architecture	748
ReFS on-disk structure	751
Object IDs	752
Security and change journal	753
ReFS advanced features	754
File's block cloning (snapshot support) and sparse VDL	754
ReFS write-through	757
ReFS recovery support	759
Leak detection	761
Shingled magnetic recording (SMR) volumes	762
ReFS support for tiered volumes and SMR	764
Container compaction	766
Compression and ghosting	769
Storage Spaces	770
Spaces internal architecture	771
Services provided by Spaces	772
Conclusion	776

Chapter 12 Startup and shutdown

777

Boot process	777
The UEFI boot	777
The BIOS boot process	781
Secure Boot	781
The Windows Boot Manager	785
The Boot menu	799
Launching a boot application	800
Measured Boot	801
Trusted execution	805
The Windows OS Loader	808
Booting from iSCSI	811
The hypervisor loader	811
VSM startup policy	813
The Secure Launch	816
Initializing the kernel and executive subsystems	818
Kernel initialization phase 1	824
Smss, Csrss, and Wininit	830
ReadyBoot	835
Images that start automatically	837
Shutdown	837
Hibernation and Fast Startup	840
Windows Recovery Environment (WinRE)	845
Safe mode	847
Driver loading in safe mode	848
Safe-mode-aware user programs	849
Boot status file	850
Conclusion	850
<i>Contents of Windows Internals, Seventh Edition, Part 1</i>	851
<i>Index</i>	861

About the Authors



ANDREA ALLIEVI is a system-level developer and security research engineer with more than 15 years of experience. He graduated from the University of Milano-Bicocca in 2010 with a bachelor's degree in computer science. For his thesis, he developed a Master Boot Record (MBR) Bootkit entirely in 64-bits, capable of defeating all the Windows 7 kernel-protections (PatchGuard and Driver Signing enforcement).

Andrea is also a reverse engineer who specializes in operating systems internals, from kernel-level code all the way to user-mode code. He

is the original designer of the first UEFI Bootkit (developed for research purposes and published in 2012), multiple PatchGuard bypasses, and many other research papers and articles. He is the author of multiple system tools and software used for removing malware and advanced persistent threads. In his career, he has worked in various computer security companies—Italian TgSoft, Saferbytes (now MalwareBytes), and Talos group of Cisco Systems Inc. He originally joined Microsoft in 2016 as a security research engineer in the Microsoft Threat Intelligence Center (MSTIC) group. Since January 2018, Andrea has been a senior core OS engineer in the Kernel Security Core team of Microsoft, where he mainly maintains and develops new features (like Retpoline or the Speculation Mitigations) for the NT and Secure Kernel.

Andrea continues to be active in the security research community, authoring technical articles on new kernel features of Windows in the Microsoft Windows Internals blog, and speaking at multiple technical conferences, such as Recon and Microsoft BlueHat. Follow Andrea on Twitter at @aall86.



ALEX IONESCU is the vice president of endpoint engineering at CrowdStrike, Inc., where he started as its founding chief architect. Alex is a world-class security architect and consultant expert in low-level system software, kernel development, security training, and reverse engineering. Over more than two decades, his security research work has led to the repair of dozens of critical security vulnerabilities in the Windows kernel and its related components, as well as multiple behavioral bugs.

Previously, Alex was the lead kernel developer for ReactOS, an open-source Windows clone written from scratch, for which he wrote most of the Windows NT-based subsystems. During his studies in computer science, Alex worked at Apple on the iOS kernel, boot loader, and drivers on the original core platform team behind the iPhone, iPad, and AppleTV. Alex is also the founder of Winsider Seminars & Solutions, Inc., a company that specializes in low-level system software, reverse engineering, and security training for various institutions.

Alex continues to be active in the community and has spoken at more than two dozen events around the world. He offers Windows Internals training, support, and resources to organizations and individuals worldwide. Follow Alex on Twitter at @aionescu and his blogs at www.alex-ionescu.com and www.windows-internals.com/blog.

Foreword

Having used and explored the internals of the wildly successful Windows 3.1 operating system, I immediately recognized the world-changing nature of Windows NT 3.1 when Microsoft released it in 1993. David Cutler, the architect and engineering leader for Windows NT, had created a version of Windows that was secure, reliable, and scalable, but with the same user interface and ability to run the same software as its older yet more immature sibling. Helen Custer's book *Inside Windows NT* was a fantastic guide to its design and architecture, but I believed that there was a need for and interest in a book that went deeper into its working details. *VAX/VMS Internals and Data Structures*, the definitive guide to David Cutler's previous creation, was a book as close to source code as you could get with text, and I decided that I was going to write the Windows NT version of that book.

Progress was slow. I was busy finishing my PhD and starting a career at a small software company. To learn about Windows NT, I read documentation, reverse-engineered its code, and wrote systems monitoring tools like Regmon and Filemon that helped me understand the design by coding them and using them to observe the under-the-hood views they gave me of Windows NT's operation. As I learned, I shared my newfound knowledge in a monthly "NT Internals" column in *Windows NT Magazine*, the magazine for Windows NT administrators. Those columns would serve as the basis for the chapter-length versions that I'd publish in *Windows Internals*, the book I'd contracted to write with IDG Press.

My book deadlines came and went because my book writing was further slowed by my full-time job and time I spent writing Sysinternals (then NTInternals) freeware and commercial software for Winternals Software, my startup. Then, in 1996, I had a shock when Dave Solomon published *Inside Windows NT*, 2nd Edition. I found the book both impressive and depressing. A complete rewrite of the Helen's book, it went deeper and broader into the internals of Windows NT like I was planning on doing, and it incorporated novel labs that used built-in tools and diagnostic utilities from the Windows NT Resource Kit and Device Driver Development Kit (DDK) to demonstrate key concepts and behaviors. He'd raised the bar so high that I knew that writing a book that matched the quality and depth he'd achieved was even more monumental than what I had planned.

As the saying goes, if you can't beat them, join them. I knew Dave from the Windows conference speaking circuit, so within a couple of weeks of the book's publication I sent him an email proposing that I join him to coauthor the next edition, which would document what was then called Windows NT 5 and would eventually be renamed as

Windows 2000. My contribution would be new chapters based on my NT Internals column about topics Dave hadn't included, and I'd also write about new labs that used my Sysinternals tools. To sweeten the deal, I suggested including the entire collection of Sysinternals tools on a CD that would accompany the book—a common way to distribute software with books and magazines.

Dave was game. First, though, he had to get approval from Microsoft. I had caused Microsoft some public relations complications with my public revelations that Windows NT Workstation and Windows NT Server were the same exact code with different behaviors based on a Registry setting. And while Dave had full Windows NT source access, I didn't, and I wanted to keep it that way so as not to create intellectual property issues with the software I was writing for Sysinternals or Winternals, which relied on undocumented APIs. The timing was fortuitous because by the time Dave asked Microsoft, I'd been repairing my relationship with key Windows engineers, and Microsoft tacitly approved.

Writing *Inside Windows 2000* with Dave was incredibly fun. Improbably and completely coincidentally, he lived about 20 minutes from me (I lived in Danbury, Connecticut and he lived in Sherman, Connecticut). We'd visit each other's houses for marathon writing sessions where we'd explore the internals of Windows together, laugh at geeky jokes and puns, and pose technical questions that would pit him and me in races to find the answer with him scouring source code while I used a disassembler, debugger, and Sysinternals tools. (Don't rub it in if you talk to him, but I always won.)

Thus, I became a coauthor to the definitive book describing the inner workings of one of the most commercially successful operating systems of all time. We brought in Alex Ionescu to contribute to the fifth edition, which covered Windows XP and Windows Vista. Alex is among the best reverse engineers and operating systems experts in the world, and he added both breadth and depth to the book, matching or exceeding our high standards for legibility and detail. The increasing scope of the book, combined with Windows itself growing with new capabilities and subsystems, resulted in the 6th Edition exceeding the single-spine publishing limit we'd run up against with the 5th Edition, so we split it into two volumes.

I had already moved to Azure when writing for the sixth edition got underway, and by the time we were ready for the seventh edition, I no longer had time to contribute to the book. Dave Solomon had retired, and the task of updating the book became even more challenging when Windows went from shipping every few years with a major release and version number to just being called Windows 10 and releasing constantly with feature and functionality upgrades. Pavel Yosifovitch stepped in to help Alex with Part 1, but he too became busy with other projects and couldn't contribute to Part 2. Alex was also busy with his startup CrowdStrike, so we were unsure if there would even be a Part 2.

Fortunately, Andrea came to the rescue. He and Alex have updated a broad swath of the system in Part 2, including the startup and shutdown process, Registry subsystem, and UWP. Not just content to provide a refresh, they've also added three new chapters that detail Hyper-V, caching and file systems, and diagnostics and tracing. The legacy of the *Windows Internals* book series being the most technically deep and accurate word on the inner workings on Windows, one of the most important software releases in history, is secure, and I'm proud to have my name still listed on the byline.

A memorable moment in my career came when we asked David Cutler to write the foreword for *Inside Windows 2000*. Dave Solomon and I had visited Microsoft a few times to meet with the Windows engineers and had met David on a few of the trips. However, we had no idea if he'd agree, so were thrilled when he did. It's a bit surreal to now be on the other side, in a similar position to his when we asked David, and I'm honored to be given the opportunity. I hope the endorsement my foreword represents gives you the same confidence that this book is authoritative, clear, and comprehensive as David Cutler's did for buyers of *Inside Windows 2000*.

Mark Russinovich
Azure Chief Technology Officer and Technical Fellow
Microsoft

March 2021
Bellevue, Washington

Introduction

Windows Internals, Seventh Edition, Part 2 is intended for advanced computer professionals (developers, security researchers, and system administrators) who want to understand how the core components of the Microsoft Windows 10 (up to and including the May 2021 Update, a.k.a. 21H1) and Windows Server (from Server 2016 up to Server 2022) operating systems work internally, including many components that are shared with Windows 11X and the Xbox Operating System.

With this knowledge, developers can better comprehend the rationale behind design choices when building applications specific to the Windows platform and make better decisions to create more powerful, scalable, and secure software. They will also improve their skills at debugging complex problems rooted deep in the heart of the system, all while learning about tools they can use for their benefit.

System administrators can leverage this information as well because understanding how the operating system works “under the hood” facilitates an understanding of the expected performance behavior of the system. This makes troubleshooting system problems much easier when things go wrong and empowers the triage of critical issues from the mundane.

Finally, security researchers can figure out how software applications and the operating system can misbehave and be misused, causing undesirable behavior, while also understanding the mitigations and security features offered by modern Windows systems against such scenarios. Forensic experts can learn which data structures and mechanisms can be used to find signs of tampering, and how Windows itself detects such behavior.

Whoever the reader might be, after reading this book, they will have a better understanding of how Windows works and why it behaves the way it does.

History of the book

This is the seventh edition of a book that was originally called *Inside Windows NT* (Microsoft Press, 1992), written by Helen Custer (prior to the initial release of Microsoft Windows NT 3.1). *Inside Windows NT* was the first book ever published about Windows NT and provided key insights into the architecture and design of the system. *Inside Windows NT, Second Edition* (Microsoft Press, 1998) was written by David Solomon. It updated the original book to cover Windows NT 4.0 and had a greatly increased level of technical depth.

Inside Windows 2000, Third Edition (Microsoft Press, 2000) was authored by David Solomon and Mark Russinovich. It added many new topics, such as startup and shutdown, service internals, registry internals, file-system drivers, and networking. It also covered kernel changes in Windows 2000, such as the Windows Driver Model (WDM), Plug and Play, power management, Windows Management Instrumentation (WMI), encryption, the job object, and Terminal Services. *Windows Internals, Fourth Edition* (Microsoft Press, 2004) was the Windows XP and Windows Server 2003 update and added more content focused on helping IT professionals make use of their knowledge of Windows internals, such as using key tools from Windows SysInternals and analyzing crash dumps.

Windows Internals, Fifth Edition (Microsoft Press, 2009) was the update for Windows Vista and Windows Server 2008. It saw Mark Russinovich move on to a full-time job at Microsoft (where he is now the Azure CTO) and the addition of a new co-author, Alex Ionescu. New content included the image loader, user-mode debugging facility, Advanced Local Procedure Call (ALPC), and Hyper-V. The next release, *Windows Internals, Sixth Edition* (Microsoft Press, 2012), was fully updated to address the many kernel changes in Windows 7 and Windows Server 2008 R2, with many new hands-on experiments to reflect changes in the tools as well.

Seventh edition changes

The sixth edition was also the first to split the book into two parts, due to the length of the manuscript having exceeded modern printing press limits. This also had the benefit of allowing the authors to publish parts of the book more quickly than others (March 2012 for Part 1, and September 2012 for Part 2). At the time, however, this split was purely based on page counts, with the same overall chapters returning in the same order as prior editions.

After the sixth edition, Microsoft began a process of OS convergence, which first brought together the Windows 8 and Windows Phone 8 kernels, and eventually incorporated the modern application environment in Windows 8.1, Windows RT, and Windows Phone 8.1. The convergence story was complete with Windows 10, which runs on desktops, laptops, cell phones, servers, Xbox One, HoloLens, and various Internet of Things (IoT) devices. With this grand unification completed, the time was right for a new edition of the series, which could now finally catch up with almost half a decade of changes.

With the seventh edition (Microsoft Press, 2017), the authors did just that, joined for the first time by Pavel Yosifovich, who took over David Solomon's role as the "Microsoft insider" and overall book manager. Working alongside Alex Ionescu, who like Mark, had moved on to his own full-time job at CrowdStrike (where is now the VP of endpoint

engineering), Pavel made the decision to refactor the book's chapters so that the two parts could be more meaningfully cohesive manuscripts instead of forcing readers to wait for Part 2 to understand concepts introduced in Part 1. This allowed Part 1 to stand fully on its own, introducing readers to the key concepts of Windows 10's system architecture, process management, thread scheduling, memory management, I/O handling, plus user, data, and platform security. Part 1 covered aspects of Windows 10 up to and including Version 1703, the May 2017 Update, as well as Windows Server 2016.

Changes in Part 2

With Alex Ionescu and Mark Russinovich consumed by their full-time jobs, and Pavel moving on to other projects, Part 2 of this edition struggled for many years to find a champion. The authors are grateful to Andrea Allievi for having eventually stepped up to carry on the mantle and complete the series. Working with advice and guidance from Alex, but with full access to Microsoft source code as past coauthors had and, for the first time, being a full-fledged developer in the Windows Core OS team, Andrea turned the book around and brought his own vision to the series.

Realizing that chapters on topics such as networking and crash dump analysis were beyond today's readers' interests, Andrea instead added exciting new content around Hyper-V, which is now a key part of the Windows platform strategy, both on Azure and on client systems. This complements fully rewritten chapters on the boot process, on new storage technologies such as ReFS and DAX, and expansive updates on both system and management mechanisms, alongside the usual hands-on experiments, which have been fully updated to take advantage of new debugger technologies and tooling.

The long delay between Parts 1 and 2 made it possible to make sure the book was fully updated to cover the latest public build of Windows 10, Version 2103 (May 2021 Update / 21H1), including Windows Server 2019 and 2022, such that readers would not be "behind" after such a long gap long gap. As Windows 11 builds upon the foundation of the same operating system kernel, readers will be adequately prepared for this upcoming version as well.

Hands-on experiments

Even without access to the Windows source code, you can glean much about Windows internals from the kernel debugger, tools from SysInternals, and the tools developed specifically for this book. When a tool can be used to expose or demonstrate some aspect of the internal behavior of Windows, the steps for trying the tool yourself are listed in special "EXPERIMENT" sections. These appear throughout the book, and we

encourage you to try them as you're reading. Seeing visible proof of how Windows works internally will make much more of an impression on you than just reading about it will.

Topics not covered

Windows is a large and complex operating system. This book doesn't cover everything relevant to Windows internals but instead focuses on the base system components. For example, this book doesn't describe COM+, the Windows distributed object-oriented programming infrastructure, or the Microsoft .NET Framework, the foundation of managed code applications. Because this is an "internals" book and not a user, programming, or system administration book, it doesn't describe how to use, program, or configure Windows.

A warning and a caveat

Because this book describes undocumented behavior of the internal architecture and the operation of the Windows operating system (such as internal kernel structures and functions), this content is subject to change between releases. By "subject to change," we don't necessarily mean that details described in this book will change between releases, but you can't count on them not changing. Any software that uses these undocumented interfaces, or insider knowledge about the operating system, might not work on future releases of Windows. Even worse, software that runs in kernel mode (such as device drivers) and uses these undocumented interfaces might experience a system crash when running on a newer release of Windows, resulting in potential loss of data to users of such software.

In short, you should never use any internal Windows functionality, registry key, behavior, API, or other undocumented detail mentioned in this book during the development of any kind of software designed for end-user systems or for any other purpose other than research and documentation. Always check with the Microsoft Software Development Network (MSDN) for official documentation on a particular topic first.

Assumptions about you

The book assumes the reader is comfortable with working on Windows at a power-user level and has a basic understanding of operating system and hardware concepts, such as CPU registers, memory, processes, and threads. Basic understanding of functions, pointers, and similar C programming language constructs is beneficial in some sections.

Organization of this book

The book is divided into two parts (as was the sixth edition), the second of which you're holding in your hands.

- Chapter 8, "System mechanisms," provides information about the important internal mechanisms that the operating system uses to provide key services to device drivers and applications, such as ALPC, the Object Manager, and synchronization routines. It also includes details about the hardware architecture that Windows runs on, including trap processing, segmentation, and side channel vulnerabilities, as well as the mitigations required to address them.
- Chapter 9, "Virtualization technologies," describes how the Windows OS uses the virtualization technologies exposed by modern processors to allow users to create and use multiple virtual machines on the same system. Virtualization is also extensively used by Windows to provide a new level of security. Thus, the Secure Kernel and Isolated User Mode are extensively discussed in this chapter.
- Chapter 10, "Management, diagnostics, and tracing," details the fundamental mechanisms implemented in the operating system for management, configuration, and diagnostics. In particular, the Windows registry, Windows services, WMI, and Task Scheduling are introduced along with diagnostics services like Event Tracing for Windows (ETW) and DTrace.
- Chapter 11, "Caching and file systems," shows how the most important "storage" components, the cache manager and file system drivers, interact to provide to Windows the ability to work with files, directories, and disk devices in an efficient and fault-safe way. The chapter also presents the file systems that Windows supports, with particular detail on NTFS and ReFS.
- Chapter 12, "Startup and shutdown," describes the flow of operations that occurs when the system starts and shuts down, and the operating system components that are involved in the boot flow. The chapter also analyzes the new technologies brought on by UEFI, such as Secure Boot, Measured Boot, and Secure Launch.

Conventions

The following conventions are used in this book:

- **Boldface** type is used to indicate text that you type as well as interface items that you are instructed to click or buttons that you are instructed to press.

- *Italic* type is used to indicate new terms.
- Code elements appear in italics or in a monospaced font, depending on context.
- The first letters of the names of dialog boxes and dialog box elements are capitalized—for example, the Save As dialog box.
- Keyboard shortcuts are indicated by a plus sign (+) separating the key names. For example, Ctrl+Alt+Delete means that you press the Ctrl, Alt, and Delete keys at the same time.

About the companion content

We have included companion content to enrich your learning experience. You can download the companion content for this book from the following page:

MicrosoftPressStore.com/WindowsInternals7ePart2/downloads

Acknowledgments

The book contains complex technical details, as well as their reasoning, which are often hard to describe and understand from an outsider's perspective. Throughout its history, this book has always had the benefit of both proving an outsider's reverse-engineering view as well as that of an internal Microsoft contractor or employee to fill in the gaps and to provide access to the vast swath of knowledge that exists within the company and the rich development history behind the Windows operating system. For this Seventh Edition, Part 2, the authors are grateful to Andrea Allievi for having joined as a main author and having helped spearhead most of the book and its updated content.

Apart from Andrea, this book wouldn't contain the depth of technical detail or the level of accuracy it has without the review, input, and support of key members of the Windows development team, other experts at Microsoft, and other trusted colleagues, friends, and experts in their own domains.

It is worth noting that the newly written Chapter 9, "Virtualization technologies" wouldn't have been so complete and detailed without the help of Alexander Grest and Jon Lange, who are world-class subject experts and deserve a special thanks, in particular for the days that they spent helping Andrea understand the inner details of the most obscure features of the hypervisor and the Secure Kernel.

Alex would like to particularly bring special thanks to Arun Kishan, Mehmet Iyigun, David Weston, and Andy Luhrs, who continue to be advocates for the book and Alex's inside access to people and information to increase the accuracy and completeness of the book.

Furthermore, we want to thank the following people, who provided technical review and/or input to the book or were simply a source of support and help to the authors: Saar Amar, Craig Barkhouse, Michelle Bergeron, Joe Bialek, Kevin Broas, Omar Carey, Neal Christiansen, Chris Fernald, Stephen Finnigan, Elia Florio, James Forshaw, Andrew Harper, Ben Hillis, Howard Kapustein, Saruhan Karademir, Chris Kleynhans, John Lambert, Attilio Mainetti, Bill Messmer, Matt Miller, Jake Oshins, Simon Pope, Jordan Rabet, Loren Robinson, Arup Roy, Yarden Shafir, Andrey Shedel, Jason Shirk, Axel Souchet, Atul Talesara, Satoshi Tanda, Pedro Teixeira, Gabrielle Viala, Nate Warfield, Matthew Woolman, and Adam Zabrocki.

We continue to thank Ilfak Guilfanov of Hex-Rays (<http://www.hex-rays.com>) for the IDA Pro Advanced and Hex-Rays licenses granted to Alex Ionescu, including most recently a lifetime license, which is an invaluable tool for speeding up the reverse engineering of the Windows kernel. The Hex-Rays team continues to support Alex's research and builds relevant new decompiler features in every release, which make writing a book such as this possible without source code access.

Finally, the authors would like to thank the great staff at Microsoft Press (Pearson) who have been behind turning this book into a reality. Loretta Yates, Charvi Arora, and their support staff all deserve a special mention for their unlimited patience from turning a contract signed in 2018 into an actual book two and a half years later.

Errata and book support

We've made every effort to ensure the accuracy of this book and its companion content. You can access updates to this book—in the form of a list of submitted errata and their related corrections at

MicrosoftPressStore.com/WindowsInternals7ePart2/errata

If you discover an error that is not already listed, please submit it to us at the same page.

For additional book support and information, please visit

<http://www.MicrosoftPressStore.com/Support>.

Please note that product support for Microsoft software and hardware is not offered through the previous addresses. For help with Microsoft software or hardware, go to

<http://support.microsoft.com>.

Stay in touch

Let's keep the conversation going! We're on Twitter: @MicrosoftPress.

System mechanisms

The Windows operating system provides several base mechanisms that kernel-mode components such as the executive, the kernel, and device drivers use. This chapter explains the following system mechanisms and describes how they are used:

- Processor execution model, including ring levels, segmentation, task states, trap dispatching, including interrupts, deferred procedure calls (DPCs), asynchronous procedure calls (APCs), timers, system worker threads, exception dispatching, and system service dispatching
- Speculative execution barriers and other software-side channel mitigations
- The executive Object Manager
- Synchronization, including spinlocks, kernel dispatcher objects, wait dispatching, and user-mode-specific synchronization primitives such as address-based waits, conditional variables, and slim reader-writer (SRW) locks
- Advanced Local Procedure Call (ALPC) subsystem
- Windows Notification Facility (WNF)
- WoW64
- User-mode debugging framework

Additionally, this chapter also includes detailed information on the Universal Windows Platform (UWP) and the set of user-mode and kernel-mode services that power it, such as the following:

- Packaged Applications and the AppX Deployment Service
- Centennial Applications and the Windows Desktop Bridge
- Process State Management (PSM) and the Process Lifetime Manager (PLM)
- Host Activity Moderator (HAM) and Background Activity Moderator (BAM)

Processor execution model

This section takes a deep look at the internal mechanics of Intel i386–based processor architecture and its extension, the AMD64-based architecture used on modern systems. Although the two respective companies first came up with these designs, it's worth noting that both vendors now implement each other's designs, so although you may still see these suffixes attached to Windows files and registry keys, the terms x86 (32-bit) and x64 (64-bit) are more common in today's usage.

We discuss concepts such as segmentation, tasks, and ring levels, which are critical mechanisms, and we discuss the concept of traps, interrupts, and system calls.

Segmentation

High-level programming languages such as C/C++ and Rust are compiled down to machine-level code, often called *assembler* or *assembly code*. In this low-level language, processor registers are accessed directly, and there are often three primary types of registers that programs access (which are visible when debugging code):

- The Program Counter (PC), which in x86/x64 architecture is called the Instruction Pointer (IP) and is represented by the EIP (x86) and RIP (x64) register. This register always points to the line of assembly code that is executing (except for certain 32-bit ARM architectures).
- The Stack Pointer (SP), which is represented by the ESP (x86) and RSP (x64) register. This register points to the location in memory that is holding the current stack location.
- Other General Purpose Registers (GPRs) include registers such as EAX/RAX, ECX/RCX, EDX/RDX, ESI/RSI and R8, R14, just to name a few examples.

Although these registers can contain address values that point to memory, additional registers are involved when accessing these memory locations as part of a mechanism called *protected mode segmentation*. This works by checking against various *segment registers*, also called *selectors*:

- All accesses to the program counter are first verified by checking against the code segment (CS) register.
- All accesses to the stack pointer are first verified by checking against the stack segment (SS) register.
- Accesses to other registers are determined by a *segment override*, which encoding can be used to force checking against a specific register such as the data segment (DS), extended segment (ES), or F segment (FS).

These selectors live in 16-bit segment registers and are looked up in a data structure called the Global Descriptor Table (GDT). To locate the GDT, the processor uses yet another CPU register, the GDT Register, or GDTR. The format of these selectors is as shown in Figure 8-1.

28-bit Offset	Table Indicator (TI)	Ring Level (0-3)
---------------	----------------------------	------------------------

FIGURE 8-1 Format of an x86 segment selector.

The offset located in the segment selector is thus looked up in the GDT, unless the TI bit is set, in which case a different structure, the *Local Descriptor Table* is used, which is identified by the LDTR register instead and is not used anymore in the modern Windows OS. The result is in a segment entry being discovered—or alternatively, an invalid entry, which will issue a General Protection Fault (#GP) or Segment Fault (#SF) exception.

This entry, called segment descriptor in modern operating systems, serves two critical purposes:

- For a code segment, it indicates the *ring level*, also called the *Code Privilege Level* (CPL) at which code running with this segment selector loaded will execute. This ring level, which can be from 0 to 3, is then cached in the bottom two bits of the actual selector, as was shown in Figure 8-1. Operating systems such as Windows use Ring 0 to run kernel mode components and drivers, and Ring 3 to run applications and services.

Furthermore, on x64 systems, the code segment also indicates whether this is a *Long Mode* or *Compatibility Mode* segment. The former is used to allow the native execution of x64 code, whereas the latter activates legacy compatibility with x86. A similar mechanism exists on x86 systems, where a segment can be marked as a 16-bit segment or a 32-bit segment.

- For other segments, it indicates the ring level, also called the *Descriptor Privilege Level* (DPL), that is required to access this segment. Although largely an anachronistic check in today's modern systems, the processor still enforces (and applications still expect) this to be set up correctly.

Finally, on x86 systems, segment entries can also have a 32-bit *base address*, which will add that value to any value already loaded in a register that is referencing this segment with an override. A corresponding *segment limit* is then used to check if the underlying register value is beyond a fixed cap. Because this base address was set to 0 (and limit to 0xFFFFFFFF) on most operating systems, the x64 architecture does away with this concept, apart from the FS and GS selectors, which operate a little bit differently:

- If the Code Segment is a Long Mode code segment, then get the base address for the FS segment from the FS_BASE Model Specific Register (MSR)—0C0000100h. For the GS segment, look at the current *swap state*, which can be modified with the **swaps** instruction, and load either the GS_BASE MSR—0C0000101h or the GS_SWAP MSR—0C0000102h.

If the TI bit is set in the FS or GS segment selector register, then get its value from the LDT entry at the appropriate offset, which is limited to a 32-bit base address only. This is done for compatibility reasons with certain operating systems, and the limit is ignored.

- If the Code Segment is a Compatibility Mode segment, then read the base address as normal from the appropriate GDT entry (or LDT entry if the TI bit is set). The limit is enforced and validated against the offset in the register following the segment override.

This interesting behavior of the FS and GS segments is used by operating systems such as Windows to achieve a sort of *thread-local register* effect, where specific data structures can be pointed to by the segment base address, allowing simple access to specific offsets/fields within it.

For example, Windows stores the address of the Thread Environment Block (TEB), which was described in Part 1, Chapter 3, “Processes and jobs,” in the FS segment on x86 and in the GS (swapped) segment on x64. Then, while executing kernel-mode code on x86 systems, the FS segment is manually modified to a different segment entry that contains the address of the Kernel Processor Control Region (KPCR) instead, whereas on x64, the GS (non-swapped) segment stores this address.

Therefore, segmentation is used to achieve these two effects on Windows—encode and enforce the level of privilege that a piece of code can execute with at the processor level and provide direct access to the TEB and KPCR data structures from user-mode and/or kernel-mode code, as appropriate. Note that since the GDT is pointed to by a CPU register—the GDTR—each CPU can have its own GDT. In fact, this is exactly what Windows uses to make sure the appropriate per-processor KPCR is loaded for each GDT, and that the TEB of the currently executing thread on the current processor is equally present in its segment.

EXPERIMENT: Viewing the GDT on an x64 system

You can view the contents of the GDT, including the state of all segments and their base addresses (when relevant) by using the **dg** debugger command, if you are doing remote debugging or analyzing a crash dump (which is also the case when using LiveKD). This command accepts the starting segment and the ending segment, which will be 10 and 50 in this example:

```
0: kd> dg 10 50
```

Se1	Base	Limit	Type	P	Si	Gr	Pr	Lo	Flags
				l	ze	an	es	ng	
0010	00000000`00000000	00000000`00000000	Code RE	Ac	0	Nb	By	P	Lo 0000029b
0018	00000000`00000000	00000000`00000000	Data RW	Ac	0	Bg	By	P	Nl 00000493
0020	00000000`00000000	00000000`ffffffff	Code RE	Ac	3	Bg	Pg	P	Nl 00000cfb
0028	00000000`00000000	00000000`ffffffff	Data RW	Ac	3	Bg	Pg	P	Nl 00000cf3
0030	00000000`00000000	00000000`00000000	Code RE	Ac	3	Nb	By	P	Lo 000002fb
0050	00000000`00000000	00000000`00003c00	Data RW	Ac	3	Bg	By	P	Nl 000004f3

The key segments here are 10h, 18h, 20h, 28h, 30h, and 50h. (This output was cleaned up a bit to remove entries that are not relevant to this discussion.)

At 10h (KGDT64_R0_CODE), you can see a Ring 0 Long Mode code segment, identified by the number 0 under the PI column, the letters “Lo” under the Long column, and the type being Code RE. Similarly, at 20h (KGDT64_R3_CMCODE), you’ll note a Ring 3 NI segment (not long—i.e., compatibility mode), which is the segment used for executing x86 code under the WoW64 subsystem, while at 30h (KGDT64_R3_CODE), you’ll find an equivalent Long Mode segment. Next, note the 18h (KGDT64_R0_DATA) and 28h (KGDT64_R3_DATA) segments, which correspond to the stack, data, and extended segment.

There's one last segment at 50h (KGDT_R3_CMTEB), which typically has a base address of zero, unless you're running some x86 code under WoW64 while dumping the GDT. This is where the base address of the TEB will be stored when running under compatibility mode, as was explained earlier.

To see the 64-bit TEB and KPCR segments, you'd have to dump the respective MSRs instead, which can be done with the following commands if you are doing local or remote kernel debugging (these commands will not work with a crash dump):

```
!kd> rdmsr c0000101
msr[c0000101] = fffffb401`a3b80000
```

```
!kd> rdmsr c0000102
msr[c0000102] = 000000e5`6dbe9000
```

You can compare these values with those of @\$pcr and @\$teb, which should show you the same values, as below:

```
!kd> dx -r0 @$pcr
@$pcr : 0xfffffb401a3b80000 [Type: _KPCR *]
```

```
!kd> dx -r0 @$teb
@$teb : 0xe56dbe9000 [Type: _TEB *]
```

EXPERIMENT: Viewing the GDT on an x86 system

On an x86 system, the GDT is laid out with similar segments, but at different selectors, additionally, due to usage of a dual FS segment instead of the *swaps* functionality, and due to the lack of Long Mode, the number of selectors is a little different, as you can see here:

```
kd> dg 8 38
```

Sel	Base	Limit	Type	P	Si	Gr	Pr	Lo	Flags
				1	ze	an	es	ng	
0008	00000000	ffffffff	Code RE Ac	0	Bg	Pg	P	N1	00000c9b
0010	00000000	ffffffff	Data RW Ac	0	Bg	Pg	P	N1	00000c93
0018	00000000	ffffffff	Code RE		3	Bg	Pg	P	N1 00000cfa
0020	00000000	ffffffff	Data RW Ac	3	Bg	Pg	P	N1	00000cf3
0030	80a9e000	00006020	Data RW Ac	0	Bg	By	P	N1	00000493
0038	00000000	00000fff	Data RW		3	Bg	By	P	N1 000004f2

The key segments here are 8h, 10h, 18h, 20h, 30h, and 38h. At 08h (KGDT_R0_CODE), you can see a Ring 0 code segment. Similarly, at 18h (KGDT_R3_CODE), note a Ring 3 segment. Next, note the 10h (KGDT_R0_DATA) and 20h (KGDT_R3_DATA) segments, which correspond to the stack, data, and extended segment.

On x86, you'll find at segment 30h (KGDT_R0_PCR) the base address of the KPCR, and at segment 38h (KGDT_R3_TEB), the base address of the current thread's TEB. There are no MSRs used for segmentation on these systems.

Lazy segment loading

Based on the description and values of the segments described earlier, it may be surprising to investigate the values of DS and ES on an x86 and/or x64 system and find that they do not necessarily match the defined values for their respective ring levels. For example, an x86 user-mode thread would have the following segments:

CS = 1Bh (18h | 3)

ES, DS = 23 (20h | 3)

FS = 3Bh (38h | 3)

Yet, during a system call in Ring 0, the following segments would be found:

CS = 08h (08h | 0)

ES, DS = 23 (20h | 3)

FS = 30h (30h | 0)

Similarly, an x64 thread executing in kernel mode would also have its ES and DS segments set to 2Bh (28h | 3). This discrepancy is due to a feature known as *lazy segment loading* and reflects the meaninglessness of the Descriptor Privilege Level (DPL) of a data segment when the current Code Privilege Level (CPL) is 0 combined with a system operating under a flat memory model. Since a higher CPL can always access data of a lower DPL—but not the contrary—setting DS and/or ES to their “proper” values upon entering the kernel would also require restoring them when returning to user mode.

Although the MOV DS, 10h instruction seems trivial, the processor’s microcode needs to perform a number of selector correctness checks when encountering it, which would add significant processing costs to system call and interrupt handling. As such, Windows always uses the Ring 3 data segment values, avoiding these associated costs.

Task state segments

Other than the code and data segment registers, there is an additional special register on both x86 and x64 architectures: the Task Register (TR), which is also another 16-bit selector that acts as an offset in the GDT. In this case, however, the segment entry is not associated with code or data, but rather with a *task*. This represents, to the processor’s internal state, the current executing piece of code, which is called the *Task State*—in the case of Windows, the current thread. These task states, represented by segments (Task State Segment, or TSS), are used in modern x86 operating systems to construct a variety of tasks that can be associated with critical processor traps (which we’ll see in the upcoming section). At minimum, a TSS represents a page directory (through the CR3 register), such as a PML4 on x64 systems (see Part 1, Chapter 5, “Memory management,” for more information on paging), a Code Segment, a Stack Segment, an Instruction Pointer, and up to four Stack Pointers (one for each ring level). Such TSSs are used in the following scenarios:

- To represent the current execution state when there is no specific trap occurring. This is then used by the processor to correctly handle interrupts and exceptions by loading the Ring 0 stack from the TSS if the processor was currently running in Ring 3.

- To work around an architectural race condition when dealing with Debug Faults (#DB), which requires a dedicated TSS with a custom debug fault handler and kernel stack.
- To represent the execution state that should be loaded when a Double Fault (#DF) trap occurs. This is used to switch to the Double Fault handler on a safe (backup) kernel stack instead of the current thread's kernel stack, which may be the reason why a fault has happened.
- To represent the execution state that should be loaded when a Non Maskable Interrupt (#NMI) occurs. Similarly, this is used to load the NMI handler on a safe kernel stack.
- Finally, to a similar task that is also used during Machine Check Exceptions (#MCE), which, for the same reasons, can run on a dedicated, safe, kernel stack.

On x86 systems, you'll find the main (current) TSS at selector 028h in the GDT, which explains why the TR register will be 028h during normal Windows execution. Additionally, the #DF TSS is at 58h, the NMI TSS is at 50h, and the #MCE TSS is at 0A0h. Finally, the #DB TSS is at 0A8h.

On x64 systems, the ability to have multiple TSSs was removed because the functionality had been relegated to mostly this one need of executing trap handlers that run on a dedicated kernel stack. As such, only a single TSS is now used (in the case of Windows, at 040h), which now has an array of eight possible stack pointers, called the Interrupt Stack Table (IST). Each of the preceding traps is now associated with an IST Index instead of a custom TSS. In the next section, as we dump a few IDT entries, you will see the difference between x86 and x64 systems and their handling of these traps.

EXPERIMENT: Viewing the TSSs on an x86 system

On an x86 system, we can look at the system-wide TSS at 28h by using the same **dg** command utilized earlier:

```
kd> dg 28 28
```

Se1	Base	Limit	Type	P	Si	Gr	Pr	Lo	Flags
				l	ze	an	es	ng	
0028	8116e400	000020ab	TSS32	Busy	0	Nb	By	P	N1 0000008b

This returns the virtual address of the KTSS data structure, which can then be dumped with the **dx** or **dt** commands:

```
kd> dx (nt!_KTSS*)0x8116e400
(nt!_KTSS*)0x8116e400 : 0x8116e400 [Type: _KTSS *]
[+0x000] Backlink : 0x0 [Type: unsigned short]
[+0x002] Reserved0 : 0x0 [Type: unsigned short]
[+0x004] Esp0 : 0x81174000 [Type: unsigned long]
[+0x008] Ss0 : 0x10 [Type: unsigned short]
```

Note that the only fields that are set in the structure are the *Esp0* and *Ss0* fields because Windows never uses hardware-based task switching outside of the trap conditions described earlier. As such, the only use for this particular TSS is to load the appropriate kernel stack during a hardware interrupt.

As you'll see in the "Trap dispatching" section, on systems that do not suffer from the "Meltdown" architectural processor vulnerability, this stack pointer will be the kernel stack pointer of the current thread (based on the KTHREAD structure seen in Part 1, Chapter 5), whereas on systems that are vulnerable, this will point to the transition stack inside of the Processor Descriptor Area. Meanwhile, the Stack Segment is always set to 10h, or KGDT_R0_DATA.

Another TSS is used for Machine Check Exceptions (#MC) as described above. We can use **dg** to look at it:

```
kd> dg a0 a0
```

Sel	Base	Limit	Type	P	Si	Gr	Pr	Lo	Flags
-----	-----	-----	-----	1	ze	an	es	ng	-----
00A0	81170590	00000067	TSS32 Avl	0	Nb	By	P	N1	00000089

This time, however, we'll use the **.tss** command instead of **dx**, which will format the various fields in the KTSS structure and display the task as if it were the currently executing thread. In this case, the input parameter is the task selector (A0h).

```
kd> .tss a0
```

```

eax=00000000 ebx=00000000 ecx=00000000 edx=00000000 esi=00000000 edi=00000000
eip=81e1a718 esp=820f5470 ebp=00000000 iopl=0         nv up di pl nz na po nc
cs=0008  ss=0010  ds=0023  es=0023  fs=0030  gs=0000             efl=00000000

hal!HalpMcaExceptionHandlerWrapper:
81e1a718 fa             cli

```

Note how the segment registers are set up as described in the "Lazy segment loading" section earlier, and how the program counter (EIP) is pointing to the handler for #MC. Additionally, the stack is configured to point to a safe stack in the kernel binary that should be free from memory corruption. Finally, although not visible in the **.tss** output, CR3 is configured to the System Page Directory. In the "Trap dispatching" section, we revisit this TSS when using the **!idt** command.

EXPERIMENT: Viewing the TSS and the IST on an x64 system

On an x64 system, the **dg** command unfortunately has a bug that does not correctly show 64-bit segment base addresses, so obtaining the TSS segment (40h) base address requires dumping what appear to be two segments, and combining the high, middle, and low base address bytes:

```
0: kd> dg 40 48
```

Sel	Base	Limit	Type	P	Si	Gr	Pr	Lo	Flags
-----	-----	-----	-----	1	ze	an	es	ng	-----
0040	00000000`7074d000	00000000`00000067	TSS32 Busy	0	Nb	By	P	N1	0000008b
0048	00000000`0000ffff	00000000`0000f802	<Reserved>	0	Nb	By	Np	N1	00000000

In this example, the `KTSS64` is therefore at **0xFFFFF8027074D000**. To showcase yet another way of obtaining it, note that the `KPCR` of each processor has a field called `TssBase`, which contains a pointer to the `KTSS64` as well:

```
0: kd> dx @$pcr->TssBase
@$pcr->TssBase           : 0xfffff8027074d000 [Type: _KTSS64 *]
    [+0x000] Reserved0    : 0x0 [Type: unsigned long]
    [+0x004] Rsp0         : 0xfffff80270757c90 [Type: unsigned __int64]
```

Note how the virtual address is the same as the one visible in the GDT. Next, you'll also notice how all the fields are zero except for `RSP0`, which, similarly to x86, contains the address of the kernel stack for the current thread (on systems without the "Meltdown" hardware vulnerability) or the address of the transition stack in the Processor Descriptor Area.

On the system on which this experiment was done, a 10th Generation Intel processor was used; therefore, `RSP0` is the current kernel stack:

```
0: kd> dx @$thread->Tcb.InitialStack
@$thread->Tcb.InitialStack : 0xfffff80270757c90 [Type: void *]
```

Finally, by looking at the Interrupt Stack Table, we can see the various stacks that are associated with the `#DF`, `#MC`, `#DB`, and `NMI` traps, and in the Trap Dispatching section, we'll see how the Interrupt Dispatch Table (IDT) references these stacks:

```
0: kd> dx @$pcr->TssBase->Ist
@$pcr->TssBase->Ist      [Type: unsigned __int64 [8]]
    [0]                  : 0x0 [Type: unsigned __int64]
    [1]                  : 0xfffff80270768000 [Type: unsigned __int64]
    [2]                  : 0xfffff8027076c000 [Type: unsigned __int64]
    [3]                  : 0xfffff8027076a000 [Type: unsigned __int64]
    [4]                  : 0xfffff8027076e000 [Type: unsigned __int64]
```

Now that the relationship between ring level, code execution, and some of the key segments in the GDT has been clarified, we'll take a look at the actual transitions that can occur between different code segments (and their ring level) in the upcoming section on trap dispatching. Before discussing trap dispatching, however, let's analyze how the TSS configuration changes in systems that are vulnerable to the Meltdown hardware side-channels attack.

Hardware side-channel vulnerabilities

Modern CPUs can compute and move data between their internal registers very quickly (in the order of pico-seconds). A processor's registers are a scarce resource. So, the OS and applications' code always instruct the CPU to move data from the CPU registers into the main memory and vice versa. There are different kinds of memory that are accessible from the main CPU. Memory located inside the CPU package and accessible directly from the CPU execution engine is called cache and has the characteristic of being fast and expensive. Memory that is accessible from the CPU through an external bus is usually the RAM (Random Access Memory) and has the characteristic of being slower, cheaper, and big

in size. The locality of the memory in respect to the CPU defines a so-called memory hierarchy based on memories of different speeds and sizes (the more memory is closer to the CPU, the more memory is faster and smaller in size). As shown in Figure 8-2, CPUs of modern computers usually include three different levels of fast cache memory, which is directly accessible by the execution engine of each physical core: L1, L2, and L3 cache. L1 and L2 caches are the closest to a CPU's core and are private per each core. L3 cache is the farthest one and is always shared between all CPU's cores (note that on embedded processors, the L3 cache usually does not exist).

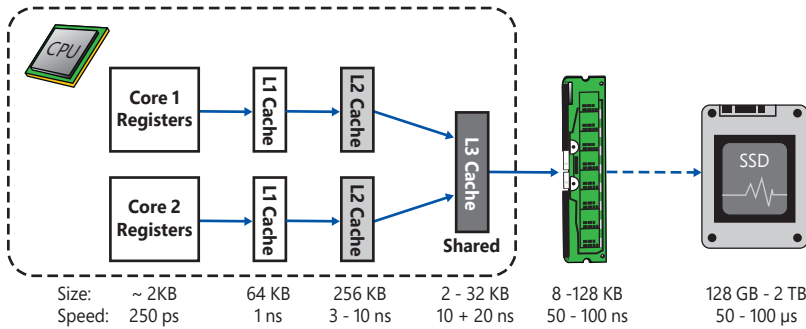

FIGURE 8-2 Caches and storage memory of modern CPUs and their average size and access time.

One of main characteristics of cache is its access time, which is comparable to CPU's registers (even though it is still slower). Access time to the main memory is instead a hundred times slower. This means that in case the CPU executes all the instructions in order, many times there would be huge slowdowns due to instructions accessing data located in the main memory. To overcome this problem, modern CPUs implement various strategies. Historically, those strategies have led to the discovery of side-channel attacks (also known as speculative attacks), which have been proven to be very effective against the overall security of the end-user systems.

To correctly describe side-channel hardware attacks and how Windows mitigates them, we should discuss some basic concepts regarding how the CPU works internally.

Out-of-order execution

A modern microprocessor executes machine instructions thanks to its pipeline. The pipeline contains many stages, including instruction fetch, decoding, register allocation and renaming, instructions reordering, execution, and retirement. A common strategy used by the CPUs to bypass the memory slowdown problem is the capability of their execution engine to execute instructions out of order as soon as the required resources are available. This means that the CPU does not execute the instructions in a strictly sequential order, maximizing the utilization of all the execution units of the CPU core as exhaustive as possible. A modern processor can execute hundreds of instructions speculatively before it is certain that those instructions will be needed and committed (retired).

One problem of the described out-of-order execution regards branch instructions. A conditional branch instruction defines two possible paths in the machine code. The correct path to be taken depends on the previously executed instructions. When calculating the condition depends on previous

instructions that access slow RAM memory, there can be slowdowns. In that case, the execution engine waits for the retirement of the instructions defining the conditions (which means waiting for the memory bus to complete the memory access) before being able to continue in the out-of-order execution of the following instructions belonging to the correct path. A similar problem happens in the case of indirect branches. In this case, the execution engine of the CPU does not know the target of a branch (usually a jump or a call) because the address must be fetched from the main memory. In this context, the term *speculative execution* means that the CPU's pipeline decodes and executes multiple instructions in parallel or in an out-of-order way, but the results are not retired into permanent registers, and memory writes remain pending until the branch instruction is finally resolved.

The CPU branch predictor

How does the CPU know which branch (path) should be executed before the branch condition has been completely evaluated? (The issue is similar with indirect branches, where the target address is not known). The answer lies in two components located in the CPU package: the branch predictor and the branch target predictor.

The branch predictor is a complex digital circuit of a CPU that tries to guess which path a branch will go before it is known definitively. In a similar way, the branch target predictor is the part of the CPU that tries to predict the target of indirect branches before it is known. While the actual hardware implementation heavily depends on the CPU manufacturer, the two components both use an internal cache called Branch Target Buffer (BTB), which records the target address of branches (or information about what the conditional branch has previously done in the past) using an address tag generated through an indexing function, similar to how the cache generates the tag, as explained in the next section. The target address is stored in the BTB the first time a branch instruction is executed. Usually, at the first time, the execution pipeline is stalled, forcing the CPU to wait for the condition or target address to be fetched from the main memory. The second time the same branch is executed, the target address in the BTB is used for fetching the predicted target into the pipeline. Figure 8-3 shows a simple scheme of an example branch target predictor.

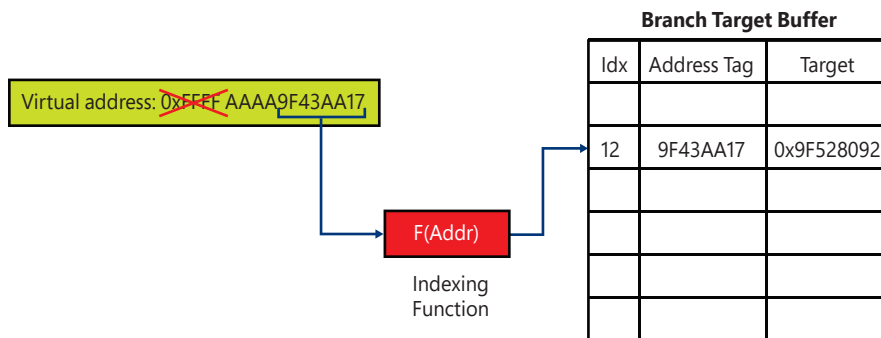

FIGURE 8-3 The scheme of a sample CPU branch predictor.

In case the prediction was wrong, and the wrong path was executed speculatively, then the instruction pipeline is flushed, and the results of the speculative execution are discarded. The other path is fed into the CPU pipeline and the execution restarts from the correct branch. This case is called *branch*

misprediction. The total number of wasted CPU cycles is not worse than an in-order execution waiting for the result of a branch condition or indirect address evaluation. However, different side effects of the speculative execution can still happen in the CPU, like the pollution of the CPU cache lines. Unfortunately, some of these side effects can be measured and exploited by attackers, compromising the overall security of the system.

The CPU cache(s)

As introduced in the previous section, the CPU cache is a fast memory that reduces the time needed for data or instructions fetch and store. Data is transferred between memory and cache in blocks of fixed sizes (usually 64 or 128 bytes) called *lines* or *cache blocks*. When a cache line is copied from memory into the cache, a cache entry is created. The cache entry will include the copied data as well as a tag identifying the requested memory location. Unlike the branch target predictor, the cache is always indexed through physical addresses (otherwise, it would be complex to deal with multiple mappings and changes of address spaces). From the cache perspective, a physical address is split in different parts. Whereas the higher bits usually represent the tag, the lower bits represent the cache line and the offset into the line. A tag is used to uniquely identify which memory address the cache block belongs to, as shown in Figure 8-4.

When the CPU reads or writes a location in memory, it first checks for a corresponding entry in the cache (in any cache lines that might contain data from that address. Some caches have different *ways* indeed, as explained later in this section). If the processor finds that the memory content from that location is in the cache, a cache hit has occurred, and the processor immediately reads or writes the data from/in the cache line. Otherwise, a cache miss has occurred. In this case, the CPU allocates a new entry in the cache and copies data from main memory before accessing it.

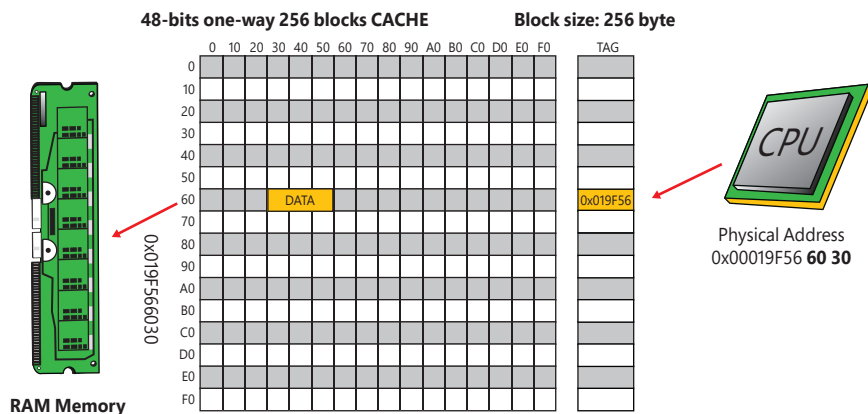

FIGURE 8-4 A sample 48-bit one-way CPU cache.

In Figure 8-4, a one-way CPU cache is shown, and it's capable of addressing a maximum 48-bits of virtual address space. In the sample, the CPU is reading 48 bytes of data located at virtual address 0x19F566030. The memory content is initially read from the main memory into the cache block 0x60. The block is entirely filled, but the requested data is located at offset 0x30. The sample cache has just

256 blocks of 256 bytes, so multiple physical addresses can fill block number 0x60. The tag (0x19F56) uniquely identifies the physical address where data is stored in the main memory.

In a similar way, when the CPU is instructed to write some new content to a memory address, it first updates the cache line(s) that the memory address belongs to. At some point, the CPU writes the data back to the physical RAM as well, depending on the caching type (write-back, write-through, uncached, and so on) applied to the memory page. (Note that this has an important implication in multiprocessor systems: A cache coherency protocol must be designed to prevent situations in which another CPU will operate on stale data after the main CPU has updated a cache block. (Multiple CPU cache coherency algorithms exist and are not covered in this book.)

To make room for new entries on cache misses, the CPU sometime should evict one of the existing cache blocks. The algorithm the cache uses to choose which entry to evict (which means which block will host the new data) is called the *placement policy*. If the placement policy can replace only one block for a particular virtual address, the cache is called *direct mapped* (the cache in Figure 8-4 has only one way and is direct mapped). Otherwise, if the cache is free to choose any entry (with the same block number) to hold the new data, the cache is called *fully associative*. Many caches implement a compromise in which each entry in main memory can go to any one of N places in the cache and are described as N-ways set associative. A *way* is thus a subdivision of a cache, with each way being of equal size and indexed in the same fashion. Figure 8-5 shows a four-way set associative cache. The cache in the figure can store data belonging to four different physical addresses indexing the same cache block (with different tags) in four different cache sets.

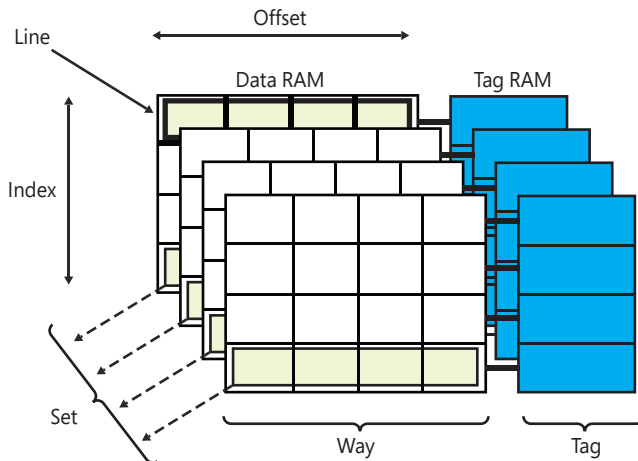

FIGURE 8-5 A four-way set associative cache.

Side-channel attacks

As discussed in the previous sections, the execution engine of modern CPUs does not write the result of the computation until the instructions are actually retired. This means that, although multiple instructions are executed out of order and do not have any visible architectural effects on CPU registers and memory, they have microarchitectural side effects, especially on the CPU cache. At the end of the year

2017, novel attacks were demonstrated against the CPU out-of-order engines and their branch predictors. These attacks relied on the fact that microarchitectural side effects can be measured, even though they are not directly accessible by any software code.

The two most destructive and effective hardware side-channel attacks were named Meltdown and Spectre.

Meltdown

Meltdown (which has been later called Rogue Data Cache load, or RDCL) allowed a malicious user-mode process to read all memory, even kernel memory, when it was not authorized to do so. The attack exploited the out-of-order execution engine of the processor and an inner race condition between the memory access and privilege check during a memory access instruction processing.

In the Meltdown attack, a malicious user-mode process starts by flushing the entire cache (instructions that do so are callable from user mode). The process then executes an illegal kernel memory access followed by instructions that fill the cache in a controlled way (using a *probe array*). The process cannot access the kernel memory, so an exception is generated by the processor. The exception is caught by the application. Otherwise, it would result in the termination of the process. However, due to the out-of-order execution, the CPU has already executed (but not retired, meaning that no architectural effects are observable in any CPU registers or RAM) the instructions following the illegal memory access that have filled the cache with the illegally requested kernel memory content.

The malicious application then probes the entire cache by measuring the time needed to access each page of the array used for filling the CPU cache's block. If the access time is behind a certain threshold, the data is in the cache line, so the attacker can infer the exact byte read from the kernel memory. Figure 8-6, which is taken from the original Meltdown research paper (available at the <https://meltdownattack.com/> web page), shows the access time of a 1 MB probe array (composed of 256 4KB pages):

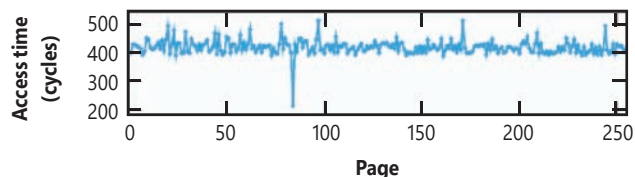

FIGURE 8-6 CPU time employed for accessing a 1 MB probe array.

Figure 8-6 shows that the access time is similar for each page, except for one. Assuming that secret data can be read one byte per time and one byte can have only 256 values, knowing the exact page in the array that led to a cache hit allows the attacker to know which byte is stored in the kernel memory.

Spectre

The Spectre attack is similar to Meltdown, meaning that it still relies on the out-of-order execution flaw explained in the previous section, but the main CPU components exploited by Spectre are the branch predictor and branch target predictor. Two variants of the Spectre attack were initially presented. Both are summarized by three phases:

1. In the setup phase, from a low-privileged process (which is attacker-controlled), the attacker performs multiple repetitive operations that mistrain the CPU branch predictor. The goal is to train the CPU to execute a (legit) path of a conditional branch or a well-defined target of an indirect branch.
2. In the second phase, the attacker forces a victim high-privileged application (or the same process) to speculatively execute instructions that are part of a mispredicted branch. Those instructions usually transfer confidential information from the victim context into a microarchitectural channel (usually the CPU cache).
3. In the final phase, from the low-privileged process, the attacker recovers the sensitive information stored in the CPU cache (microarchitectural channel) by probing the entire cache (the same methods employed in the Meltdown attack). This reveals secrets that should be secured in the victim high-privileged address space.

The first variant of the Spectre attack can recover secrets stored in a victim process's address space (which can be the same or different than the address space that the attacker controls), by forcing the CPU branch predictor to execute the wrong branch of a conditional branch speculatively. The branch is usually part of a function that performs a bound check before accessing some nonsecret data contained in a memory buffer. If the buffer is located adjacent to some secret data, and if the attacker controls the offset supplied to the branch condition, she can repetitively train the branch predictor supplying legal offset values, which satisfies the bound check and allows the CPU to execute the correct path.

The attacker then prepares in a well-defined way the CPU cache (such that the size of the memory buffer used for the bound check wouldn't be in the cache) and supplies an illegal offset to the function that implements the bound check branch. The CPU branch predictor is trained to always follow the initial legit path. However, this time, the path would be wrong (the other should be taken). The instructions accessing the memory buffer are thus speculatively executed and result in a read outside the boundaries, which targets the secret data. The attacker can thus read back the secrets by probing the entire cache (similar to the Meltdown attack).

The second variant of Spectre exploits the CPU branch target predictor; indirect branches can be poisoned by an attacker. The mispredicted path of an indirect branch can be used to read arbitrary memory of a victim process (or the OS kernel) from an attacker-controlled context. As shown in Figure 8-7, for variant 2, the attacker mistrains the branch predictor with malicious destinations, allowing the CPU to build enough information in the BTB to speculatively execute instructions located at an address chosen by the attacker. In the victim address space, that address should point to a gadget. A *gadget* is a group of instructions that access a secret and store it in a buffer that is cached in a controlled way (the attacker needs to indirectly control the content of one or more CPU registers in the victim, which is a common case when an API accepts untrusted input data).

After the attacker has trained the branch target predictor, she flushes the CPU cache and invokes a service provided by the target higher-privileged entity (a process or the OS kernel). The code that implements the service must implement similar indirect branches as the attacker-controlled process. The CPU branch target predictor in this case speculatively executes the gadget located at the wrong target address. This, as for Variant 1 and Meltdown, creates microarchitectural side effects in the CPU cache, which can be read from the low-privileged context.

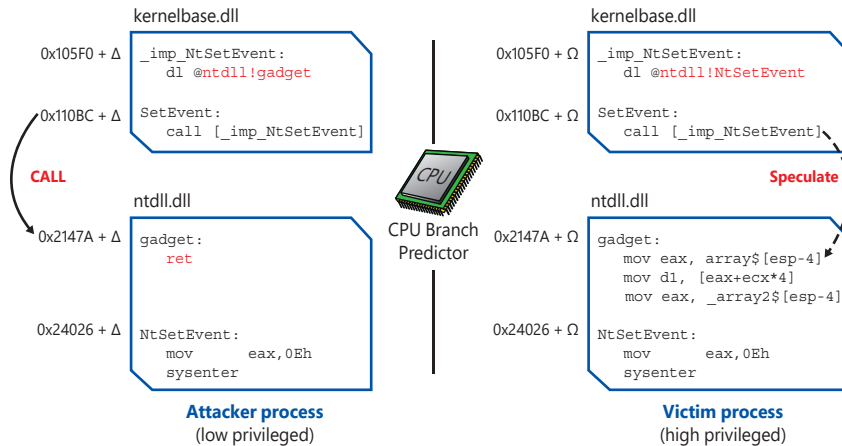

FIGURE 8-7 A scheme of Spectre attack Variant 2.

Other side-channel attacks

After Spectre and Meltdown attacks were originally publicly released, multiple similar side-channel hardware attacks were discovered. Even though they were less destructive and effective compared to Meltdown and Spectre, it is important to at least understand the overall methodology of those new side-channel attacks.

Speculative store bypass (SSB) arises due to a CPU optimization that can allow a load instruction, which the CPU evaluated not to be dependent on a previous store, to be speculatively executed before the results of the store are retired. If the prediction is not correct, this can result in the load operation reading stale data, which can potentially store secrets. The data can be forwarded to other operations executed during speculation. Those operations can access memory and generate microarchitectural side effects (usually in the CPU cache). An attacker can thus measure the side effects and recover the secret value.

The Foreshadow (also known as *LITF*) is a more severe attack that was originally designed for stealing secrets from a hardware enclave (SGX) and then generalized also for normal user-mode software executing in a non-privileged context. Foreshadow exploited two hardware flaws of the speculative execution engine of modern CPUs. In particular:

- **Speculation on inaccessible virtual memory.** In this scenario, when the CPU accesses some data stored at a virtual address described by a Page table entry (PTE) that does not include the present bit (meaning that the address is not valid) an exception is correctly generated. However, if the entry contains a valid address translation, the CPU can speculatively execute the instructions that depend on the read data. As for all the other side-channel attacks, those instructions are not retired by the processor, but they produce measurable side effects. In this scenario, a user-mode application would be able to read secret data stored in kernel memory. More seriously, the application, under certain circumstances, would also be able to read data belonging

to another virtual machine: when the CPU encounters a nonpresent entry in the Second Level Address Translation table (SLAT) while translating a guest physical address (GPA), the same side effects can happen. (More information on the SLAT, GPAs, and translation mechanisms are present in Chapter 5 of Part 1 and in Chapter 9, “Virtualization technologies”).

- Speculation on the logical (hyper-threaded) processors of a CPU’s core. Modern CPUs can have more than one execution pipeline per physical core, which can execute in an out-of-order way multiple instruction streams using a single shared execution engine (this is Symmetric multi-threading, or SMT, as explained later in Chapter 9.) In those processors, two logical processors (LPs) share a single cache. Thus, while an LP is executing some code in a high-privileged context, the other sibling LP can read the side effects produced by the high-privileged code executed by the other LP. This has very severe effects on the global security posture of a system. Similar to the first Foreshadow variant, an LP executing the attacker code on a low-privileged context can even spoil secrets stored in another high-security virtual-machine just by waiting for the virtual machine code that will be scheduled for execution by the sibling LP. This variant of Foreshadow is part of the Group 4 vulnerabilities.

Microarchitectural side effects are not always targeting the CPU cache. Intel CPUs use other intermediate high-speed buffers with the goal to better access cached and noncached memory and reorder micro-instructions. (Describing all those buffers is outside the scope of this book.) The Microarchitectural Data Sampling (MDS) group of attacks exposes secrets data located in the following microarchitectural structures:

- **Store buffers** While performing store operations, processors write data into an internal temporary microarchitectural structure called store buffer, enabling the CPU to continue to execute instructions before the data is actually written in the cache or main memory (for noncached memory access). When a load operation reads data from the same memory address as an earlier store, the processor may be able to forward data directly from the store buffer.
- **Fill buffers** A fill buffer is an internal processor structure used to gather (or write) data on a first level data cache miss (and on I/O or special registers operations). Fill buffers are the intermediary between the CPU cache and the CPU out-of-order execution engine. They may retain data from prior memory requests, which may be speculatively forwarded to a load operation.
- **Load ports** Load ports are temporary internal CPU structures used to perform load operations from memory or I/O ports.

Microarchitectural buffers usually belong to a single CPU core and are shared between SMT threads. This implies that, even if attacks on those structures are hard to achieve in a reliable way, the speculative extraction of secret data stored into them is also potentially possible across SMT threads (under specific conditions).

In general, the outcome of all the hardware side-channel vulnerabilities is the same: secrets will be spoiled from the victim address space. Windows implements various mitigations for protecting against Spectre, Meltdown, and almost all the described side-channel attacks.

Side-channel mitigations in Windows

This section takes a peek at how Windows implements various mitigations for defending against side-channel attacks. In general, some side-channel mitigations are implemented by CPU manufacturers through microcode updates. Not all of them are always available, though; some mitigations need to be enabled by the software (Windows kernel).

KVA Shadow

Kernel virtual address shadowing, also known as KVA shadow (or KPTI in the Linux world, which stands for Kernel Page Table Isolation) mitigates the Meltdown attack by creating a distinct separation between the kernel and user page tables. Speculative execution allows the CPU to spoil kernel data when the processor is not at the correct privilege level to access it, but it requires that a valid page frame number be present in the page table translating the target kernel page. The kernel memory targeted by the Meltdown attack is generally translated by a valid leaf entry in the system page table, which indicates only supervisor privilege level is allowed. (Page tables and virtual address translation are covered in Chapter 5 of Part 1.) When KVA shadow is enabled, the system allocates and uses two top-level page tables for each process:

- The kernel page tables map the entire process address space, including kernel and user pages. In Windows, user pages are mapped as nonexecutable to prevent kernel code to execute memory allocated in user mode (an effect similar to the one brought by the hardware SMEP feature).
- The User page tables (also called shadow page tables) map only user pages and a minimal set of kernel pages, which do not contain any sort of secrets and are used to provide a minimal functionality for switching page tables, kernel stacks, and to handle interrupts, system calls, and other transitions and traps. This set of kernel pages is called *transition* address space.

In the transition address space, the NT kernel usually maps a data structure included in the processor's PRCB, called `KPROCESSOR_DESCRIPTOR_AREA`, which includes data that needs to be shared between the user (or shadow) and kernel page tables, like the processor's TSS, GDT, and a copy of the kernel mode GS segment base address. Furthermore, the transition address space includes all the *shadow* trap handlers located in the `“.KVASCODE”` section of the NT Kernel image.

A system with KVA shadow enabled runs unprivileged user-mode threads (i.e., running without Administrator-level privileges) in processes that do not have mapped any kernel page that may contain secrets. The Meltdown attack is not effective anymore; kernel pages are not mapped as valid in the process's page table, and any sort of speculation in the CPU targeting those pages simply cannot happen. When the user process invokes a system call, or when an interrupt happens while the CPU is executing code in the user-mode process, the CPU builds a trap frame on a *transition stack*, which, as specified before, is mapped in both the user and kernel page tables. The CPU then executes the code of the shadow trap handler that handles the interrupt or system call. The latter normally switches to the kernel page tables, copies the trap frame on the kernel stack, and then jumps to the original trap handler (this implies that a well-defined algorithm for flushing stale entries in the TLB must be properly implemented. The TLB flushing algorithm is described later in this section.) The original trap handler is executed with the entire address space mapped.

Initialization

The NT kernel determines whether the CPU is susceptible to Meltdown attack early in phase -1 of its initialization, after the processor feature bits are calculated, using the internal *KiDetectKvaLeakage* routine. The latter obtains processor's information and sets the internal *KiKvaLeakage* variable to 1 for all Intel processors except Atoms (which are in-order processors).

In case the internal *KiKvaLeakage* variable is set, KVA shadowing is enabled by the system via the *KiEnableKvaShadowing* routine, which prepares the processor's TSS (Task State Segment) and transition stacks. The RSP0 (kernel) and IST stacks of the processor's TSS are set to point to the proper transition stacks. Transition stacks (which are 512 bytes in size) are prepared by writing a small data structure, called *KIST_BASE_FRAME* on the base of the stack. The data structure allows the transition stack to be linked against its nontransition kernel stack (accessible only after the page tables have been switched), as illustrated by Figure 8-8. Note that the data structure is not needed for the regular non-IST kernel stacks. The OS obtains all the needed data for the user-to-kernel switch from the CPU's PRCB. Each thread has a proper kernel stack. The scheduler set a kernel stack as active by linking it in the processor PRCB when a new thread is selected to be executed. This is a key difference compared to the IST stacks, which exist as one per processor.

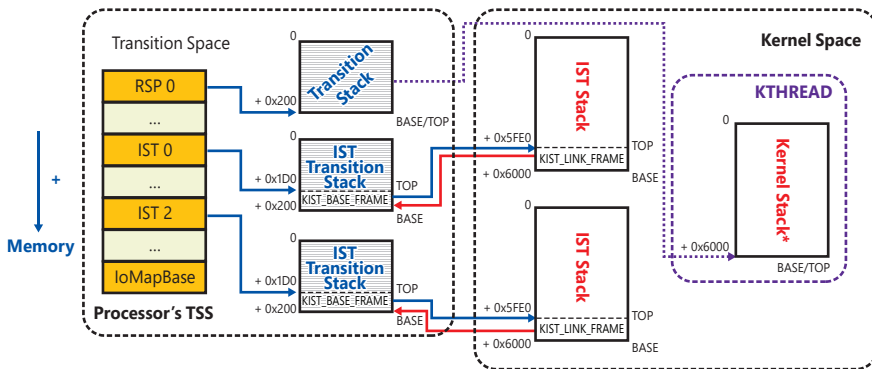

FIGURE 8-8 Configuration of the CPU's Task State Segment (TSS) when KVA shadowing is active.

The *KiEnableKvaShadowing* routine also has the important duty of determining the proper TLB flush algorithm (explained later in this section). The result of the determination (global entries or PCIDs) is stored in the global *KiKvaShadowMode* variable. Finally, for non-boot processors, the routine invokes *KiShadowProcessorAllocation*, which maps the per-processor shared data structures in the shadow page tables. For the BSP processor, the mapping is performed later in phase 1, after the SYSTEM process and its shadow page tables are created (and the IRQL is dropped to passive level). The shadow trap handlers are mapped in the user page tables only in this case (they are global and not per-processor specific).

Shadow page tables

Shadow (or user) page tables are allocated by the memory manager using the internal *MiAllocateProcessShadow* routine only when a process's address space is being created. The shadow page tables for the new process are initially created empty. The memory manager then copies all the kernel shadow top-level page table entries of the SYSTEM process in the new process shadow page table.

This allows the OS to quickly map the entire transition address space (which lives in kernel and is shared between all user-mode processes) in the new process. For the SYSTEM process, the shadow page tables remain empty. As introduced in the previous section, they will be filled thanks to the *KiShadowProcessorAllocation* routine, which uses memory manager services to map individual chunks of memory in the shadow page tables and to rebuild the entire page hierarchy.

The shadow page tables are updated by the memory manager only in specific cases. Only the kernel can write in the process page tables to map or unmap chunks of memory. When a request to allocate or map new memory into a user process address space, it may happen that the top-level page table entry for a particular address would be missing. In this case, the memory manager allocates all the pages for the entire page-table hierarchy and stores the new top-level PTE in the kernel page tables. However, in case KVA shadow is enabled, this is not enough; the memory manager must also write the top-level PTE on the shadow page table. Otherwise, the address will be not present in the user-mapping after the trap handler correctly switches the page tables before returning to user mode.

Kernel addresses are mapped in a different way in the transition address space compared to the kernel page tables. To prevent false sharing of addresses close to the chunk of memory being mapped in the transition address space, the memory manager always recreates the page table hierarchy mapping for the PTE(s) being shared. This implies that every time the kernel needs to map some new pages in the transition address space of a process, it *must* replicate the mapping in all the processes' shadow page tables (the internal *MiCopyTopLevelMappings* routine performs exactly this operation).

TLB flushing algorithm

In the x86 architecture, switching page tables usually results in the flushing of the current processor's TLB (translation look-aside buffer). The TLB is a cache used by the processor to quickly translate the virtual addresses that are used while executing code or accessing data. A valid entry in the TLB allows the processor to avoid consulting the page tables chain, making execution faster. In systems without KVA shadow, the entries in the TLB that translate kernel addresses do not need to be explicitly flushed: in Windows, the kernel address space is mostly unique and shared between all processes. Intel and AMD introduced different techniques to avoid flushing kernel entries on every page table switching, like the global/non-global bit and the Process-Context Identifiers (PCIDs). The TLB and its flushing methodologies are described in detail in the Intel and AMD architecture manuals and are not further discussed in this book.

Using the new CPU features, the operating system is able to only flush user entries and keep performance fast. This is clearly not acceptable in KVA shadow scenarios where a thread is obligated to switch page tables even when entering or exiting the kernel. In systems with KVA enabled, Windows employs an algorithm able to explicitly flush kernel and user TLB entries only when needed, achieving the following two goals:

- No valid kernel entries will be ever maintained in the TLB when executing a thread user-code. Otherwise, this could be leveraged by an attacker with the same speculation techniques used in Meltdown, which could lead her to read secret kernel data.
- Only the minimum amount of TLB entries will be flushed when switching page tables. This will keep the performance degradation introduced by KVA shadowing acceptable.

The TLB flushing algorithm is implemented in mainly three scenarios: context switch, trap entry, and trap exit. It can run on a system that either supports only the global/non-global bit or also PCIDs. In the former case, differently from the non-KVA shadow configurations, all the kernel pages are labeled as non-global, whereas the transition and user pages are labeled as global. Global pages are not flushed while a page table switch happens (the system changes the value of the CR3 register). Systems with PCID support label kernel pages with PCID 2, whereas user pages are labelled with PCID 1. The global and non-global bits are ignored in this case.

When the current-executing thread ends its quantum, a context switch is initialized. When the kernel schedules execution for a thread belonging to another process address space, the TLB algorithm assures that all the user pages are removed from the TLB (which means that in systems with global/non-global bit a full TLB flush is needed. User pages are indeed marked as global). On kernel trap exits (when the kernel finishes code execution and returns to user mode) the algorithm assures that all the kernel entries are removed (or invalidated) from the TLB. This is easily achievable: on processors with global/non-global bit support, just a reload of the page tables forces the processor to invalidate all the non-global pages, whereas on systems with PCID support, the user-page tables are reloaded using the User PCID, which automatically invalidates all the stale kernel TLB entries.

The strategy allows kernel trap entries, which can happen when an interrupt is generated while the system was executing user code or when a thread invokes a system call, not to invalidate anything in the TLB. A scheme of the described TLB flushing algorithm is represented in Table 8-1.

TABLE 8-1 KVA shadowing TLB flushing strategies

Configuration Type	User Pages	Kernel Pages	Transition Pages
KVA shadowing disabled	Non-global	Global	N / D
KVA shadowing enabled, PCID strategy	PCID 1, non-global	PCID 2, non-global	PCID 1, non-global
KVA shadowing enabled, global/non-global strategy	Global	Non-global	Global

Hardware indirect branch controls (IBRS, IBPB, STIBP, SSBD)

Processor manufacturers have designed hardware mitigations for various side-channel attacks. Those mitigations have been designed to be used with the software ones. The hardware mitigations for side-channel attacks are mainly implemented in the following indirect branch controls mechanisms, which are usually exposed through a bit in CPU model-specific registers (MSR):

- Indirect Branch Restricted Speculation (IBRS)** completely disables the branch predictor (and clears the branch predictor buffer) on switches to a different security context (user vs kernel mode or VM root vs VM non-root). If the OS sets IBRS after a transition to a more privileged mode, predicted targets of indirect branches cannot be controlled by software that was executed in a less privileged mode. Additionally, when IBRS is on, the predicted targets of indirect branches cannot be controlled by another logical processor. The OS usually sets IBRS to 1 and keeps it on until it returns to a less privileged security context.

The implementation of IBRS depends on the CPU manufacturer: some CPUs completely disable branch predictors buffers when IBRS is set to on (describing an inhibit behavior), while some

others just flush the predictor's buffers (describing a flush behavior). In those CPUs the IBRS mitigation control works in a very similar way to IBPB, so usually the CPU implement only IBRS.

- **Indirect Branch Predictor Barrier (IBPB)** flushes the content of the branch predictors when it is set to 1, creating a barrier that prevents software that executed previously from controlling the predicted targets of indirect branches on the same logical processor.
- **Single Thread Indirect Branch Predictors (STIBP)** restricts the sharing of branch prediction between logical processors on a physical CPU core. Setting STIBP to 1 on a logical processor prevents the predicted targets of indirect branches on a current executing logical processor from being controlled by software that executes (or executed previously) on another logical processor of the same core.
- **Speculative Store Bypass Disable (SSBD)** instructs the processor to not speculatively execute loads until the addresses of all older stores are known. This ensures that a load operation does not speculatively consume stale data values due to bypassing an older store on the same logical processor, thus protecting against Speculative Store Bypass attack (described earlier in the "Other side-channel attacks" section).

The NT kernel employs a complex algorithm to determine the value of the described indirect branch controls, which usually changes in the same scenarios described for KVA shadowing: context switches, trap entries, and trap exits. On compatible systems, the system runs kernel code with IBRS always on (except when Retpoline is enabled). When no IBRS is available (but IBPB and STIBP are supported), the kernel runs with STIBP on, flushing the branch predictor buffers (with an IBPB) on every trap entry (in that way the branch predictor can't be influenced by code running in user mode or by a sibling thread running in another security context). SSBD, when supported by the CPU, is always enabled in kernel mode.

For performance reasons, user-mode threads are generally executed with no hardware speculation mitigations enabled or just with STIBP on (depending on STIBP pairing being enabled, as explained in the next section). The protection against Speculative Store Bypass must be manually enabled if needed through the global or per-process Speculation feature. Indeed, all the speculation mitigations can be fine-tuned through the global HKLM\System\CurrentControlSet\Control\Session Manager\Memory Management\FeatureSettings registry value. The value is a 32-bit bitmask, where each bit corresponds to an individual setting. Table 8-2 describes individual feature settings and their meaning.

TABLE 8-2 Feature settings and their values

Name	Value	Meaning
FEATURE_SETTINGS_DISABLE_IBRS_EXCEPT_HVROOT	0x1	Disable IBRS except for non-nested root partition (default setting for Server SKUs)
FEATURE_SETTINGS_DISABLE_KVA_SHADOW	0x2	Force KVA shadowing to be disabled
FEATURE_SETTINGS_DISABLE_IBRS	0x4	Disable IBRS, regardless of machine configuration
FEATURE_SETTINGS_SET_SSB Always	0x8	Always set SSBD in kernel and user
FEATURE_SETTINGS_SET_SSB In Kernel	0x10	Set SSBD only in kernel mode (leaving user-mode code to be vulnerable to SSB attacks)
FEATURE_SETTINGS_USER_STIBP Always	0x20	Always keep STIBP on for user-threads, regardless of STIBP pairing

Name	Value	Meaning
FEATURE_SETTINGS_DISABLE_USER_TO_USER	0x40	Disables the default speculation mitigation strategy (for AMD systems only) and enables the user-to-user only mitigation. When this flag is set, no speculation controls are set when running in kernel mode.
FEATURE_SETTINGS_DISABLE_STIBP_PAIRING	0x80	Always disable STIBP pairing
FEATURE_SETTINGS_DISABLE_RETPOLINE	0x100	Always disable Retpoline
FEATURE_SETTINGS_FORCE_ENABLE_RETPOLINE	0x200	Enable Retpoline regardless of the CPU support of IBPB or IBRS (Retpoline needs at least IBPB to properly protect against Spectre v2)
FEATURE_SETTINGS_DISABLE_IMPORT_LINKING	0x20000	Disable Import Optimization regardless of Retpoline

Retpoline and import optimization

Keeping hardware mitigations enabled has strong performance penalties for the system, simply because the CPU's branch predictor is limited or disabled when the mitigations are enabled. This was not acceptable for games and mission-critical applications, which were running with a lot of performance degradation. The mitigation that was bringing most of the performance degradation was IBRS (or IBPB), while used for protecting against Spectre. Protecting against the first variant of Spectre was possible without using any hardware mitigations thanks to the memory fence instructions. A good example is the LFENCE, available in the x86 architecture. Those instructions force the processor not to execute any new operations speculatively before the fence itself completes. Only when the fence completes (and all the instructions located before it have been retired) will the processor's pipeline restart to execute (and to speculate) new opcodes. The second variant of Spectre was still requiring hardware mitigations, though, which implies all the performance problems brought by IBRS and IBPB.

To overcome the problem, Google engineers designed a novel binary-modification technique called Retpoline. The Retpoline sequence, shown in Figure 8-9, allows indirect branches to be isolated from speculative execution. Instead of performing a vulnerable indirect call, the processor jumps to a safe control sequence, which dynamically modifies the stack, captures eventual speculation, and lands to the new target thanks to a "return" operation.

```

Trampoline:
    call SetupTarget    ; push address of CaptureSpec on the stack

CaptureSpec:
    int 3              ; Breakpoint to capture speculation
    jmp CaptureSpec    ; (similar to a LFENCE barrier)

SetupTarget:
    mov QWORD PTR [rsp], r10 ; Overwrite return address on the stack
    ret                ; Return

```

FIGURE 8-9 Retpoline code sequence of x86 CPUs.

In Windows, Retpoline is implemented in the NT kernel, which can apply the Retpoline code sequence to itself and to external driver images dynamically through the Dynamic Value Relocation Table (DVRT). When a kernel image is compiled with Retpoline enabled (through a compatible compiler), the

compiler inserts an entry in the image's DVRT for each indirect branch that exists in the code, describing its address and type. The opcode that performs the indirect branch is kept as it is in the final code but augmented with a variable size padding. The entry in the DVRT includes all the information that the NT kernel needs to modify the indirect branch's opcode dynamically. This architecture ensures that external drivers compiled with Retpoline support can run also on older OS versions, which will simply skip parsing the entries in the DVRT table.



Note The DVRT was originally developed for supporting kernel ASLR (Address Space Layout Randomization, discussed in Chapter 5 of Part 1). The table was later extended to include Retpoline descriptors. The system can identify which version of the table an image includes.

In phase -1 of its initialization, the kernel detects whether the processor is vulnerable to Spectre, and, in case the system is compatible and enough hardware mitigations are available, it enables Retpoline and applies it to the NT kernel image and the HAL. The *RtlPerformRetpolineRelocationsOnImage* routine scans the DVRT and replaces each indirect branch described by an entry in the table with a direct branch, which is not vulnerable to speculative attacks, targeting the Retpoline code sequence. The original target address of the indirect branch is saved in a CPU register (R10 in AMD and Intel processors), with a single instruction that overwrites the padding generated by the compiler. The Retpoline code sequence is stored in the RETPOL section of the NT kernel's image. The page backing the section is mapped in the end of each driver's image.

Before being started, boot drivers are physically relocated by the internal *MiReloadBootLoadedDrivers* routine, which also applies the needed fixups to each driver's image, including Retpoline. All the boot drivers, the NT kernel, and HAL images are allocated in a contiguous virtual address space by the Windows Loader and do not have an associated control area, rendering them not pageable. This means that all the memory backing the images is always resident, and the NT kernel can use the same *RtlPerformRetpolineRelocationsOnImage* function to modify each indirect branch in the code directly. If HVCI is enabled, the system must call the Secure Kernel to apply Retpoline (through the *PERFORM_RETPOLINE_RELOCATIONS* secure call). Indeed, in that scenario, the drivers' executable memory is protected against any modification, following the W^X principle described in Chapter 9. Only the Secure Kernel is allowed to perform the modification.



Note Retpoline and Import Optimization fixups are applied by the kernel to boot drivers before Patchguard (also known as Kernel Patch Protection; see Part 1, Chapter 7, "Security," for further details) initializes and protects some of them. It is illegal for drivers and the NT kernel itself to modify code sections of protected drivers.

Runtime drivers, as explained in Chapter 5 of Part 1, are loaded by the NT memory manager, which creates a section object backed by the driver's image file. This implies that a control area, including a prototype PTEs array, is created to track the pages of the memory section. For driver sections, some of the physical pages are initially brought in memory just for code integrity verification and then moved in the standby list. When the section is later mapped and the driver's pages are accessed for the first

time, physical pages from the standby list (or from the backing file) are materialized on-demand by the page fault handler. Windows applies Retpoline on the *shared* pages pointed by the prototype PTEs. If the same section is also mapped by a user-mode application, the memory manager creates new *private* pages and copies the content of the shared pages in the private ones, reverting Retpoline (and Import Optimization) fixups.



Note Some newer Intel processors also speculate on “return” instructions. For those CPUs, Retpoline cannot be enabled because it would not be able to protect against Spectre v2. In this situation, only hardware mitigations can be applied. Enhanced IBRS (a new hardware mitigation) solves the performance problems of IBRS.

The Retpoline bitmap

One of the original design goals (restraints) of the Retpoline implementation in Windows was to support a mixed environment composed of drivers compatible with Retpoline and drivers not compatible with it, while maintaining the overall system protection against Spectre v2. This implies that drivers that do not support Retpoline should be executed with IBRS on (or STIBP followed by an IBPB on kernel entry, as discussed previously in the “Hardware indirect branch controls” section), whereas others can run without any hardware speculation mitigations enabled (the protection is brought by the Retpoline code sequences and memory fences).

To dynamically achieve compatibility with older drivers, in the phase 0 of its initialization, the NT kernel allocates and initializes a dynamic bitmap that keeps track of each 64 KB chunk that compose the entire kernel address space. In this model, a bit set to 1 indicates that the 64-KB chunk of address space contains Retpoline compatible code; a 0 means the opposite. The NT kernel then sets to 1 the bits referring to the address spaces of the HAL and NT images (which are always Retpoline compatible). Every time a new kernel image is loaded, the system tries to apply Retpoline to it. If the application succeeds, the respective bits in the Retpoline bitmap are set to 1.

The Retpoline code sequence is augmented to include a bitmap check: Every time an indirect branch is performed, the system checks whether the original call target resides in a Retpoline-compatible module. In case the check succeeds (and the relative bit is 1), the system executes the Retpoline code sequence (shown in Figure 8-9) and lands in the target address securely. Otherwise (when the bit in the Retpoline bitmap is 0), a Retpoline exit sequence is initialized. The `RUNNING_NON_RETPOLINE_CODE` flag is set in the current CPU’s PRCB (needed for context switches), IBRS is enabled (or STIBP, depending on the hardware configuration), an IBPB and LFENCE are emitted if needed, and the `SPEC_CONTROL` kernel event is generated. Finally, the processor lands on the target address, still in a secure way (hardware mitigations provide the needed protection).

When the thread quantum ends, and the scheduler selects a new thread, it saves the Retpoline status (represented by the presence of the `RUNNING_NON_RETPOLINE_CODE` flag) of the current processors in the `KTHREAD` data structure of the old thread. In this way, when the old thread is selected again for execution (or a kernel trap entry happens), the system knows that it needs to re-enable the needed hardware speculation mitigations with the goal of keeping the system always protected.

Import optimization

Retpoline entries in the DVRT also describe indirect branches targeting imported functions. An imported control transfer entry in the DVRT describes this kind of branch by using an index referring to the correct entry in the IAT. (The IAT is the Image Import Address Table, an array of imported functions' pointers compiled by the loader.) After the Windows loader has compiled the IAT, it is unlikely that its content would have changed (excluding some rare scenarios). As shown in Figure 8-10, it turns out that it is not needed to transform an indirect branch targeting an imported function to a Retpoline one because the NT kernel can ensure that the virtual addresses of the two images (caller and callee) are close enough to directly invoke the target (less than 2 GB).

```
StandardCall:
    call QWORD PTR [IAT+ExAllocatePoolOffset] ; 7 bytes
    nop DWORD PTR [RAX+RAX] ; 5 bytes

ImportOptimizedCall:
    mov R10, QWORD PTR [IAT+ExAllocatePoolOffset] ; 7 bytes
    call ExAllocatePool ; Direct call (5 bytes)

RetpolineOnly:
    mov R10, QWORD PTR [IAT+ExAllocatePoolWithTagOffset] ; 7 bytes
    call _retpoline_import_r10 ; Direct call (5 bytes)
```

FIGURE 8-10 Different indirect branches on the *ExAllocatePool* function.

Import optimization (internally also known as “import linking”) is the feature that uses Retpoline dynamic relocations to transform indirect calls targeting imported functions into direct branches. If a direct branch is used to divert code execution to an imported function, there is no need to apply Retpoline because direct branches are not vulnerable to speculation attacks. The NT kernel applies Import Optimization at the same time it applies Retpoline, and even though the two features can be configured independently, they use the same DVRT entries to work correctly. With Import Optimization, Windows has been able to gain a performance boost even on systems that are not vulnerable to Spectre v2. (A direct branch does not require any additional memory access.)

STIBP pairing

In hyperthreaded systems, for protecting user-mode code against Spectre v2, the system should run user threads with at least STIBP on. On nonhyperthreaded systems, this is not needed: protection against a previous user-mode thread speculation is already achieved thanks to the IBRS being enabled while previously executing kernel-mode code. In case Retpoline is enabled, the needed IBPB is emitted in the first kernel trap return executed after a cross-process thread switch. This ensures that the CPU branch prediction buffer is empty before executing the code of the user thread.

Leaving STIBP enabled in a hyper-threaded system has a performance penalty, so by default it is disabled for user-mode threads, leaving a thread to be potentially vulnerable by speculation from a sibling SMT thread. The end-user can manually enable STIBP for user threads through the

USER_STIBP_ALWAYS feature setting (see the “Hardware Indirect Branch Controls” section previously in this chapter for more details) or through the RESTRICT_INDIRECT_BRANCH_PREDICTION process mitigation option.

The described scenario is not ideal. A better solution is implemented in the STIBP pairing mechanism. STIBP pairing is enabled by the I/O manager in phase 1 of the NT kernel initialization (using the *KeOptimizeSpecCtrlSettings* function) only under certain conditions. The system should have hyper-threading enabled, and the CPU should support IBRS and STIBP. Furthermore, STIBP pairing is compatible only on non-nested virtualized environments or when Hyper-V is disabled (refer to Chapter 9 for further details.)

In an STIBP pairing scenario, the system assigns to each process a security domain identifier (stored in the *EPROCESS* data structure), which is represented by a 64-bit number. The *system* security domain identifier (which equals 0) is assigned only to processes running under the System or a fully administrative token. Nonsystem security domains are assigned at process creation time (by the internal *PspInitializeProcessSecurity* function) following these rules:

- If the new process is created without a new primary token explicitly assigned to it, it obtains the same security domain of the parent process that creates it.
- In case a new primary token is explicitly specified for the new process (by using the *CreateProcessAsUser* or *CreateProcessWithLogon* APIs, for example), a new user security domain ID is generated for the new process, starting from the internal *PsNextSecurityDomain* symbol. The latter is incremented every time a new domain ID is generated (this ensures that during the system lifetime, no security domains can collide).
- Note that a new primary token can be also assigned using the *NtSetInformationProcess* API (with the *ProcessAccessToken* information class) after the process has been initially created. For the API to succeed, the process should have been created as suspended (no threads run in it). At this stage, the process still has its original token in an unfrozen state. A new security domain is assigned following the same rules described earlier.

Security domains can also be assigned manually to different processes belonging to the same group. An application can replace the security domain of a process with another one of a process belonging to the same group using the *NtSetInformationProcess* API with the *ProcessCombineSecurityDomainsInformation* class. The API accepts two process handles and replaces the security domain of the first process only if the two tokens are frozen, and the two processes can open each other with the *PROCESS_VM_WRITE* and *PROCESS_VM_OPERATION* access rights.

Security domains allow the STIBP pairing mechanism to work. STIBP pairing links a logical processor (LP) with its sibling (both share the same physical core). In this section, we use the term LP and CPU interchangeably). Two LPs are paired by the STIBP pairing algorithm (implemented in the internal *KiUpdateStibpPairing* function) only when the security domain of the local CPU is the same as the one of the remote CPU, or one of the two LPs is Idle. In these cases, both the LPs can run without STIBP being set and still be implicitly protected against speculation (there is no advantage in attacking a sibling CPU running in the same security context).

The STIBP pairing algorithm is implemented in the *KiUpdateStibpPairing* function and includes a full state machine. The routine is invoked by the trap exit handler (invoked when the system exits the kernel for executing a user-mode thread) only in case the pairing state stored in the CPU's PRCB is stale. The pairing state of an LP can become stale mainly for two reasons:

- The NT scheduler has selected a new thread to be executed in the current CPU. If the new thread security domain is different than the previous one, the CPU's PRCB pairing state is marked as stale. This allows the STIBP pairing algorithm to re-evaluate the pairing state of the two.
- When the sibling CPU exits from its idle state, it requests the remote CPU to re-evaluate its STIBP pairing state.

Note that when an LP is running code with STIBP enabled, it is protected from the sibling CPU speculation. STIBP pairing has been developed based also on the opposite notion: when an LP executes with STIBP enabled, it is guaranteed that its sibling CPU is protected against itself. This implies that when a context switches to a different security domain, there is no need to interrupt the sibling CPU even though it is running user-mode code with STIBP disabled.

The described scenario is not true only when the scheduler selects a VP-dispatch thread (backing a virtual processor of a VM in case the Root scheduler is enabled; see Chapter 9 for further details) belonging to the VMMEM process. In this case, the system immediately sends an IPI to the sibling thread for updating its STIBP pairing state. Indeed, a VP-dispatch thread runs guest-VM code, which can always decide to disable STIBP, moving the sibling thread in an unprotected state (both runs with STIBP disabled).

EXPERIMENT: Querying system side-channel mitigation status

Windows exposes side-channel mitigation information through the *SystemSpeculationControlInformation* and *SystemSecureSpeculationControlInformation* information classes used by the *NtQuerySystemInformation* native API. Multiple tools exist that interface with this API and show to the end user the system side-channel mitigation status:

- The *SpeculationControl* PowerShell script, developed by Matt Miller and officially supported by Microsoft, which is open source and available at the following GitHub repository: <https://github.com/microsoft/SpeculationControl>
- The *SpecuCheck* tool, developed by Alex Ionescu (one of the authors of this book), which is open source and available at the following GitHub repository: <https://github.com/ionescu007/SpecuCheck>
- The *SkTool*, developed by Andrea Allievi (one of the authors of this book) and distributed (at the time of this writing) in newer Insider releases of Windows.

All of the three tools yield more or less the same results. Only the *SkTool* is able to show the side-channel mitigations implemented in the Secure Kernel, though (the hypervisor and the Secure Kernel are described in detail in Chapter 9.) In this experiment, you will understand which

mitigations have been enabled in your system. Download SpecuCheck and execute it by opening a command prompt window (type cmd in the Cortana search box). You should get output like the following:

```
SpecuCheck v1.1.1 -- Copyright(c) 2018 Alex Ionescu
https://ionescu007.github.io/SpecuCheck/ -- @aionescu
```

```
-----
Mitigations for CVE-2017-5754 [rogue data cache load]
-----
```

```
[-] Kernel VA Shadowing Enabled:          yes
    > Unnecessary due lack of CPU vulnerability:  no
    > With User Pages Marked Global:           no
    > With PCID Support:                       yes
    > With PCID Flushing Optimization (INVPCID): yes
```

```
Mitigations for CVE-2018-3620 [L1 terminal fault]
```

```
[-] L1TF Mitigation Enabled:             yes
    > Unnecessary due lack of CPU vulnerability:  no
    > CPU Microcode Supports Data Cache Flush:   yes
    > With KVA Shadow and Invalid PTE Bit:       yes
```

(The output has been trimmed for space reasons.)

You can also download the latest Windows Insider release and try the SkTool. When launched with no command-line arguments, by default the tool displays the status of the hypervisor and Secure Kernel. To show the status of all the side-channel mitigations, you should invoke the tool with the /mitigations command-line argument:

```
Hypervisor / Secure Kernel / Secure Mitigations Parser Tool 1.0
```

```
Querying Speculation Features... Success!
This system supports Secure Speculation Controls.
```

```
System Speculation Features.
```

```
Enabled: 1
Hardware support: 1
IBRS Present: 1
STIBP Present: 1
SMEP Enabled: 1
Speculative Store Bypass Disable (SSBD) Available: 1
Speculative Store Bypass Disable (SSBD) Supported by OS: 1
Branch Predictor Buffer (BPB) flushed on Kernel/User transition: 1
Retpoline Enabled: 1
Import Optimization Enabled: 1
SystemGuard (Secure Launch) Enabled: 0 (Capable: 0)
SystemGuard SMM Protection (Intel PPAM / AMD SMI monitor) Enabled: 0
```

```
Secure system Speculation Features.
```

```
KVA Shadow supported: 1
KVA Shadow enabled: 1
KVA Shadow TLB flushing strategy: PCIDs
Minimum IBPB Hardware support: 0
IBRS Present: 0 (Enhanced IBRS: 0)
```



```
STIBP Present: 0
SSBD Available: 0 (Required: 0)
Branch Predictor Buffer (BPB) flushed on Kernel/User transition: 0
Branch Predictor Buffer (BPB) flushed on User/Kernel and VTL 1 transition: 0
L1TF mitigation: 0
Microarchitectural Buffers clearing: 1
```

Trap dispatching

Interrupts and exceptions are operating system conditions that divert the processor to code outside the normal flow of control. Either hardware or software can generate them. The term *trap* refers to a processor's mechanism for capturing an executing thread when an exception or an interrupt occurs and transferring control to a fixed location in the operating system. In Windows, the processor transfers control to a *trap handler*, which is a function specific to a particular interrupt or exception. Figure 8-11 illustrates some of the conditions that activate trap handlers.

The kernel distinguishes between interrupts and exceptions in the following way. An *interrupt* is an asynchronous event (one that can occur at any time) that is typically unrelated to what the processor is executing. Interrupts are generated primarily by I/O devices, processor clocks, or timers, and they can be enabled (turned on) or disabled (turned off). An *exception*, in contrast, is a synchronous condition that usually results from the execution of a specific instruction. (*Aborts*, such as machine checks, are a type of processor exception that's typically not associated with instruction execution.) Both exceptions and aborts are sometimes called *faults*, such as when talking about a *page fault* or a *double fault*. Running a program for a second time with the same data under the same conditions can reproduce exceptions. Examples of exceptions include memory-access violations, certain debugger instructions, and divide-by-zero errors. The kernel also regards system service calls as exceptions (although technically they're system traps).

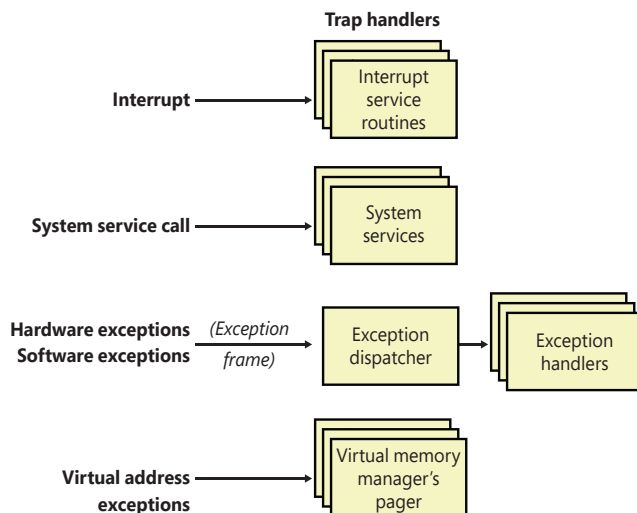

FIGURE 8-11 Trap dispatching.

Either hardware or software can generate exceptions and interrupts. For example, a bus error exception is caused by a hardware problem, whereas a divide-by-zero exception is the result of a software bug. Likewise, an I/O device can generate an interrupt, or the kernel itself can issue a software interrupt (such as an APC or DPC, both of which are described later in this chapter).

When a hardware exception or interrupt is generated, x86 and x64 processors first check whether the current Code Segment (CS) is in CPL 0 or below (i.e., if the current thread was running in kernel mode or user mode). In the case where the thread was already running in Ring 0, the processor saves (or *pushes*) on the current stack the following information, which represents a kernel-to-kernel transition.

- The current processor flags (EFLAGS/RFLAGS)
- The current code segment (CS)
- The current program counter (EIP/RIP)
- Optionally, for certain kind of exceptions, an *error code*

In situations where the processor was actually running user-mode code in Ring 3, the processor first looks up the current TSS based on the Task Register (TR) and switches to the SS0/ESP0 on x86 or simply RSP0 on x64, as described in the “Task state segments” section earlier in this chapter. Now that the processor is executing on the kernel stack, it saves the previous SS (the user-mode value) and the previous ESP (the user-mode stack) first and then saves the same data as during kernel-to-kernel transitions.

Saving this data has a twofold benefit. First, it records enough machine state on the kernel stack to return to the original point in the current thread’s control flow and continue execution as if nothing had happened. Second, it allows the operating system to know (based on the saved CS value) where the trap came from—for example, to know if an exception came from user-mode code or from a kernel system call.

Because the processor saves only enough information to restore control flow, the rest of the machine state—including registers such as EAX, EBX, ECX, EDI, and so on is saved in a trap frame, a data structure allocated by Windows in the thread’s kernel stack. The trap frame stores the execution state of the thread, and is a superset of a thread’s complete context, with additional state information. You can view its definition by using the `dt nt!_KTRAP_FRAME` command in the kernel debugger, or, alternatively, by downloading the Windows Driver Kit (WDK) and examining the NTDDK.H header file, which contains the definition with additional commentary. (Thread context is described in Chapter 5 of Part 1.) The kernel handles software interrupts either as part of hardware interrupt handling or synchronously when a thread invokes kernel functions related to the software interrupt.

In most cases, the kernel installs front-end, trap-handling functions that perform general trap-handling tasks before and after transferring control to other functions that field the trap. For example, if the condition was a device interrupt, a kernel hardware interrupt trap handler transfers control to the *interrupt service routine* (ISR) that the device driver provided for the interrupting device. If the condition was caused by a call to a system service, the general system service trap handler transfers control to the specified system service function in the executive.

In unusual situations, the kernel can also receive traps or interrupts that it doesn’t expect to see or handle. These are sometimes called *spurious* or *unexpected* traps. The trap handlers typically execute

the system function *KeBugCheckEx*, which halts the computer when the kernel detects problematic or incorrect behavior that, if left unchecked, could result in data corruption. The following sections describe interrupt, exception, and system service dispatching in greater detail.

Interrupt dispatching

Hardware-generated interrupts typically originate from I/O devices that must notify the processor when they need service. Interrupt-driven devices allow the operating system to get the maximum use out of the processor by overlapping central processing with I/O operations. A thread starts an I/O transfer to or from a device and then can execute other useful work while the device completes the transfer. When the device is finished, it interrupts the processor for service. Pointing devices, printers, keyboards, disk drives, and network cards are generally interrupt driven.

System software can also generate interrupts. For example, the kernel can issue a software interrupt to initiate thread dispatching and to break into the execution of a thread asynchronously. The kernel can also disable interrupts so that the processor isn't interrupted, but it does so only infrequently—at critical moments while it's programming an interrupt controller or dispatching an exception, for example.

The kernel installs interrupt trap handlers to respond to device interrupts. Interrupt trap handlers transfer control either to an external routine (the ISR) that handles the interrupt or to an internal kernel routine that responds to the interrupt. Device drivers supply ISRs to service device interrupts, and the kernel provides interrupt-handling routines for other types of interrupts.

In the following subsections, you'll find out how the hardware notifies the processor of device interrupts, the types of interrupts the kernel supports, how device drivers interact with the kernel (as a part of interrupt processing), and the software interrupts the kernel recognizes (plus the kernel objects that are used to implement them).

Hardware interrupt processing

On the hardware platforms supported by Windows, external I/O interrupts come into one of the inputs on an interrupt controller, for example an I/O Advanced Programmable Interrupt Controller (IOAPIC). The controller, in turn, interrupts one or more processors' Local Advanced Programmable Interrupt Controllers (LAPIC), which ultimately interrupt the processor on a single input line.

Once the processor is interrupted, it queries the controller to get the *global system interrupt vector* (GSIV), which is sometimes represented as an *interrupt request* (IRQ) number. The interrupt controller translates the GSIV to a processor interrupt vector, which is then used as an index into a data structure called the *interrupt dispatch table* (IDT) that is stored in the CPU's IDT Register, or IDTR, which returns the matching IDT entry for the interrupt vector.

Based on the information in the IDT entry, the processor can transfer control to an appropriate interrupt dispatch routine running in Ring 0 (following the process described at the start of this section), or it can even load a new TSS and update the Task Register (TR), using a process called an *interrupt gate*.

In the case of Windows, at system boot time, the kernel fills in the IDT with pointers to both dedicated kernel and HAL routines for each exception and internally handled interrupt, as well as with pointers to *thunk* kernel routines called KilsrThunk, that handle external interrupts that third-party device drivers can register for. On x86 and x64-based processor architectures, the first 32 IDT entries, associated with interrupt vectors 0–31 are marked as reserved for processor traps, which are described in Table 8-3.

TABLE 8-3 Processor traps

Vector (Mnemonic)	Meaning
0 (#DE)	Divide error
1 (#DB)	Debug trap
2 (NMI)	Nonmaskable interrupt
3 (#BP)	Breakpoint trap
4 (#OF)	Overflow fault
5 (#BR)	Bound fault
6 (#UD)	Undefined opcode fault
7 (#NM)	FPU error
8 (#DF)	Double fault
9 (#MF)	Coprocessor fault (no longer used)
10 (#TS)	TSS fault
11 (#NP)	Segment fault
12 (#SS)	Stack fault
13 (#GP)	General protection fault
14 (#PF)	Page fault
15	Reserved
16 (#MF)	Floating point fault
17 (#AC)	Alignment check fault
18 (#MC)	Machine check abort
19 (#XM)	SIMD fault
20 (#VE)	Virtualization exception
21 (#CP)	Control protection exception
22-31	Reserved

The remainder of the IDT entries are based on a combination of hardcoded values (for example, vectors 30 to 34 are always used for Hyper-V-related VMBus interrupts) as well as negotiated values between the device drivers, hardware, interrupt controller(s), and platform software such as ACPI. For example, a keyboard controller might send interrupt vector 82 on one particular Windows system and 67 on a different one.

EXPERIMENT: Viewing the 64-bit IDT

You can view the contents of the IDT, including information on what trap handlers Windows has assigned to interrupts (including exceptions and IRQs), using the **!idt** kernel debugger command. The **!idt** command with no flags shows simplified output that includes only registered hardware interrupts (and, on 64-bit machines, the processor trap handlers).

The following example shows what the output of the **!idt** command looks like on an x64 system:

```
0: kd> !idt
```

```
Dumping IDT: fffff8027074c000
```

```
00: fffff8026e1bc700 nt!KiDivideErrorFault
01: fffff8026e1bca00 nt!KiDebugTrapOrFault Stack = 0xFFFFF8027076E000
02: fffff8026e1bce00 nt!KiNmiInterrupt Stack = 0xFFFFF8027076A000
03: fffff8026e1bd380 nt!KiBreakpointTrap
04: fffff8026e1bd680 nt!KiOverflowTrap
05: fffff8026e1bd980 nt!KiBoundFault
06: fffff8026e1bde80 nt!KiInvalidOpcodeFault
07: fffff8026e1be340 nt!KiNpxNotAvailableFault
08: fffff8026e1be600 nt!KiDoubleFaultAbort Stack = 0xFFFFF80270768000
09: fffff8026e1be8c0 nt!KiNpxSegmentOverrunAbort
0a: fffff8026e1beb80 nt!KiInvalidTssFault
0b: fffff8026e1bee40 nt!KiSegmentNotPresentFault
0c: fffff8026e1bf1c0 nt!KiStackFault
0d: fffff8026e1bf500 nt!KiGeneralProtectionFault
0e: fffff8026e1bf840 nt!KiPageFault
10: fffff8026e1bfe80 nt!KiFloatingErrorFault
11: fffff8026e1c0200 nt!KiAlignmentFault
12: fffff8026e1c0500 nt!KiMcheckAbort Stack = 0xFFFFF8027076C000
13: fffff8026e1c0fc0 nt!KiXmmException
14: fffff8026e1c1380 nt!KiVirtualizationException
15: fffff8026e1c1840 nt!KiControlProtectionFault
1f: fffff8026e1b5f50 nt!KiApcInterrupt
20: fffff8026e1b7b00 nt!KiSwInterrupt
29: fffff8026e1c1d00 nt!KiRaiseSecurityCheckFailure
2c: fffff8026e1c2040 nt!KiRaiseAssertion
2d: fffff8026e1c2380 nt!KiDebugServiceTrap
2f: fffff8026e1b80a0 nt!KiDpcInterrupt
30: fffff8026e1b64d0 nt!KiHvInterrupt
31: fffff8026e1b67b0 nt!KiVmbusInterrupt0
32: fffff8026e1b6a90 nt!KiVmbusInterrupt1
33: fffff8026e1b6d70 nt!KiVmbusInterrupt2
34: fffff8026e1b7050 nt!KiVmbusInterrupt3
35: fffff8026e1b48b8 hal!HalpInterruptCmciService (KINTERRUPT fffff8026ea59fe0)
b0: fffff8026e1b4c90 ACPI!ACPIInterruptServiceRoutine (KINTERRUPT fffff8026ea598dc0)
ce: fffff8026e1b4d80 hal!HalpIommuInterruptRoutine (KINTERRUPT fffff8026ea5a9e0)
d1: fffff8026e1b4d98 hal!HalpTimerClockInterrupt (KINTERRUPT fffff8026ea5a7e0)
d2: fffff8026e1b4da0 hal!HalpTimerClockIpiRoutine (KINTERRUPT fffff8026ea5a6e0)
d7: fffff8026e1b4dc8 hal!HalpInterruptRebootService (KINTERRUPT fffff8026ea5a4e0)
d8: fffff8026e1b4dd0 hal!HalpInterruptStubService (KINTERRUPT fffff8026ea5a2e0)
df: fffff8026e1b4e08 hal!HalpInterruptSpuriousService (KINTERRUPT fffff8026ea5a1e0)
e1: fffff8026e1b8570 nt!KiIpiInterrupt
e2: fffff8026e1b4e20 hal!HalpInterruptLocalErrorService (KINTERRUPT fffff8026ea5a3e0)
```

```
e3:      fffff8026e1b4e28  hal!HalpInterruptDeferredRecoveryService
          (KINTERRUPT fffff8026ea5a0e0)
fd:      fffff8026e1b4ef8  hal!HalpTimerProfileInterrupt (KINTERRUPT fffff8026ea5a8e0)
fe:      fffff8026e1b4f00  hal!HalpPerfInterrupt (KINTERRUPT fffff8026ea5a5e0)
```

On the system used to provide the output for this experiment, the ACPI SCI ISR is at interrupt number B0h. You can also see that interrupt 14 (0Eh) corresponds to *KiPageFault*, which is a type of predefined CPU trap, as explained earlier.

You can also note that some of the interrupts—specifically 1, 2, 8, and 12—have a Stack pointer next to them. These correspond to the traps explained in the section on “Task state segments” from earlier, which require dedicated safe kernel stacks for processing. The debugger knows these stack pointers by dumping the IDT entry, which you can do as well by using the **dx** command and dereferencing one of the interrupt vectors in the IDT. Although you can obtain the IDT from the processor’s IDTR, you can also obtain it from the kernel’s KPCR structure, which has a pointer to it in a field called *IdtBase*.

```
0: kd> dx @$pcr->IdtBase[2].IstIndex
@$pcr->IdtBase[2].IstIndex : 0x3 [Type: unsigned short]
```

```
0: kd> dx @$pcr->IdtBase[0x12].IstIndex
@$pcr->IdtBase[0x12].IstIndex : 0x2 [Type: unsigned short]
```

If you compare the IDT Index values seen here with the previous experiment on dumping the x64 TSS, you should find the matching kernel stack pointers associated with this experiment.

Each processor has a separate IDT (pointed to by their own IDTR) so that different processors can run different ISRs, if appropriate. For example, in a multiprocessor system, each processor receives the clock interrupt, but only one processor updates the system clock in response to this interrupt. All the processors, however, use the interrupt to measure thread quantum and to initiate rescheduling when a thread’s quantum ends. Similarly, some system configurations might require that a particular processor handle certain device interrupts.

Programmable interrupt controller architecture

Traditional x86 systems relied on the i8259A Programmable Interrupt Controller (PIC), a standard that originated with the original IBM PC. The i8259A PIC worked only with uniprocessor systems and had only eight interrupt lines. However, the IBM PC architecture defined the addition of a second PIC, called the *secondary*, whose interrupts are multiplexed into one of the primary PIC’s interrupt lines. This provided 15 total interrupts (7 on the primary and 8 on the secondary, multiplexed through the master’s eighth interrupt line). Because PICs had such a quirky way of handling more than 8 devices, and because even 15 became a bottleneck, as well as due to various electrical issues (they were prone to spurious interrupts) and the limitations of uniprocessor support, modern systems eventually phased out this type of interrupt controller, replacing it with a variant called the i82489 Advanced Programmable Interrupt Controller (APIC).

Because APICs work with multiprocessor systems, Intel and other companies defined the Multiprocessor Specification (MPS), a design standard for x86 multiprocessor systems that centered on the use of

APIC and the integration of both an I/O APIC (IOAPIC) connected to external hardware devices to a Local APIC (LAPIC), connected to the processor core. With time, the MPS standard was folded into the Advanced Configuration and Power Interface (ACPI)—a similar acronym to APIC by chance. To provide compatibility with uniprocessor operating systems and boot code that starts a multiprocessor system in uniprocessor mode, APICs support a PIC compatibility mode with 15 interrupts and delivery of interrupts to only the primary processor. Figure 8-12 depicts the APIC architecture.

As mentioned, the APIC consists of several components: an I/O APIC that receives interrupts from devices, local APICs that receive interrupts from the I/O APIC on the bus and that interrupt the CPU they are associated with, and an i8259A-compatible interrupt controller that translates APIC input into PIC-equivalent signals. Because there can be multiple I/O APICs on the system, motherboards typically have a piece of core logic that sits between them and the processors. This logic is responsible for implementing interrupt routing algorithms that both balance the device interrupt load across processors and attempt to take advantage of locality, delivering device interrupts to the same processor that has just fielded a previous interrupt of the same type. Software programs can reprogram the I/O APICs with a fixed routing algorithm that bypasses this piece of chipset logic. In most cases, Windows will reprogram the I/O APIC with its own routing logic to support various features such as *interrupt steering*, but device drivers and firmware also have a say.

Because the x64 architecture is compatible with x86 operating systems, x64 systems must provide the same interrupt controllers as the x86. A significant difference, however, is that the x64 versions of Windows refused to run on systems that did not have an APIC because they use the APIC for interrupt control, whereas x86 versions of Windows supported both PIC and APIC hardware. This changed with Windows 8 and later versions, which only run on APIC hardware regardless of CPU architecture. Another difference on x64 systems is that the APIC's Task Priority Register, or TPR, is now directly tied to the processor's Control Register 8 (CR8). Modern operating systems, including Windows, now use this register to store the current software interrupt priority level (in the case of Windows, called the IRQL) and to inform the IOAPIC when it makes routing decisions. More information on IRQL handling will follow shortly.

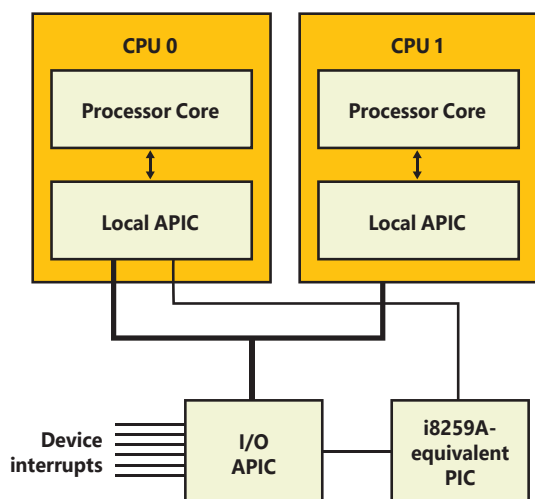

FIGURE 8-12 APIC architecture.

EXPERIMENT: Viewing the PIC and APIC

You can view the configuration of the PIC on a uniprocessor and the current local APIC on a multiprocessor by using the **!pic** and **!apic** kernel debugger commands, respectively. Here's the output of the **!pic** command on a uniprocessor. Note that even on a system with an APIC, this command still works because APIC systems always have an associated PIC-equivalent for emulating legacy hardware.

```
lkd> !pic
----- IRQ Number ----- 00 01 02 03 04 05 06 07 08 09 0A 0B 0C 0D 0E 0F
Physically in service:  Y . . . . . Y Y Y . . . .
Physically masked:     Y Y Y Y Y Y Y Y Y Y Y Y Y Y Y Y
Physically requested:  Y . . . . . Y Y Y . . . .
Level Triggered:      . . . . . . . . . . . . . .
```

Here's the output of the **!apic** command on a system running with Hyper-V enabled, which you can see due to the presence of the **SINTI** entries, referring to Hyper-V's Synthetic Interrupt Controller (SynIC), described in Chapter 9. Note that during local kernel debugging, this command shows the APIC associated with the current processor—in other words, whichever processor the debugger's thread happens to be running on as you enter the command. When looking at a crash dump or remote system, you can use the **~** (tilde) command followed by the processor number to switch the processor of whose local APIC you want to see. In either case, the number next to the **ID:** label will tell you which processor you are looking at.

```
lkd> !apic
Apic (x2Apic mode) ID:1 (50014) LogDesc:00000002 TPR 00
TimeCnt: 00000000c1k SpurVec:df FaultVec:e2 error:0
Ipi Cmd: 00000000`0004001f Vec:1f FixedDel Dest=Self edg high
Timer..: 00000000`000300d8 Vec:D8 FixedDel Dest=Self edg high m
Linti0.: 00000000`000100d8 Vec:D8 FixedDel Dest=Self edg high m
Linti1.: 00000000`00000400 Vec:00 NMI Dest=Self edg high
Sinti0.: 00000000`00020030 Vec:30 FixedDel Dest=Self edg high
Sinti1.: 00000000`00010000 Vec:00 FixedDel Dest=Self edg high m
Sinti2.: 00000000`00010000 Vec:00 FixedDel Dest=Self edg high m
Sinti3.: 00000000`000000d1 Vec:D1 FixedDel Dest=Self edg high
Sinti4.: 00000000`00020030 Vec:30 FixedDel Dest=Self edg high
Sinti5.: 00000000`00020031 Vec:31 FixedDel Dest=Self edg high
Sinti6.: 00000000`00020032 Vec:32 FixedDel Dest=Self edg high
Sinti7.: 00000000`00010000 Vec:00 FixedDel Dest=Self edg high m
Sinti8.: 00000000`00010000 Vec:00 FixedDel Dest=Self edg high m
Sinti9.: 00000000`00010000 Vec:00 FixedDel Dest=Self edg high m
Sintia.: 00000000`00010000 Vec:00 FixedDel Dest=Self edg high m
Sintib.: 00000000`00010000 Vec:00 FixedDel Dest=Self edg high m
Sintic.: 00000000`00010000 Vec:00 FixedDel Dest=Self edg high m
Sintid.: 00000000`00010000 Vec:00 FixedDel Dest=Self edg high m
Sintie.: 00000000`00010000 Vec:00 FixedDel Dest=Self edg high m
Sintif.: 00000000`00010000 Vec:00 FixedDel Dest=Self edg high m
TMR: 95, A5, B0
IRR:
ISR:
```

The various numbers following the *Vec* labels indicate the associated vector in the IDT with the given command. For example, in this output, interrupt number 0x1F is associated with the Interrupt Processor Interrupt (IPI) vector, and interrupt number 0xE2 handles APIC errors. Going back to the **!idt** output from the earlier experiment, you can notice that 0x1F is the kernel's APC Interrupt (meaning that an IPI was recently used to send an APC from one processor to another), and 0xE2 is the HAL's Local APIC Error Handler, as expected.

The following output is for the **!ioapic** command, which displays the configuration of the I/O APICs, the interrupt controller components connected to devices. For example, note how GSIV/IRQ 9 (the System Control Interrupt, or SCI) is associated with vector B0h, which in the **!idt** output from the earlier experiment was associated with ACPI.SYS.

```
0: kd> !ioapic
Controller at 0xfffff7a8c0000898 I/O APIC at VA 0xfffff7a8c0012000
IoApic @ FEC00000 ID:8 (11) Arb:0
Inti00.: 00000000`000100ff Vec:FF FixedDe1 Ph:00000000      edg high      m
Inti01.: 00000000`000100ff Vec:FF FixedDe1 Ph:00000000      edg high      m
Inti02.: 00000000`000100ff Vec:FF FixedDe1 Ph:00000000      edg high      m
Inti03.: 00000000`000100ff Vec:FF FixedDe1 Ph:00000000      edg high      m
Inti04.: 00000000`000100ff Vec:FF FixedDe1 Ph:00000000      edg high      m
Inti05.: 00000000`000100ff Vec:FF FixedDe1 Ph:00000000      edg high      m
Inti06.: 00000000`000100ff Vec:FF FixedDe1 Ph:00000000      edg high      m
Inti07.: 00000000`000100ff Vec:FF FixedDe1 Ph:00000000      edg high      m
Inti08.: 00000000`000100ff Vec:FF FixedDe1 Ph:00000000      edg high      m
Inti09.: ff000000`000089b0 Vec:B0 LowestD1 Lg:ff000000      lvl high
Inti0A.: 00000000`000100ff Vec:FF FixedDe1 Ph:00000000      edg high      m
Inti0B.: 00000000`000100ff Vec:FF FixedDe1 Ph:00000000      edg high      m
```

Software interrupt request levels (IRQLs)

Although interrupt controllers perform interrupt prioritization, Windows imposes its own interrupt priority scheme known as *interrupt request levels* (IRQLs). The kernel represents IRQLs internally as a number from 0 through 31 on x86 and from 0 to 15 on x64 (and ARM/ARM64), with higher numbers representing higher-priority interrupts. Although the kernel defines the standard set of IRQLs for software interrupts, the HAL maps hardware-interrupt numbers to the IRQLs. Figure 8-13 shows IRQLs defined for the x86 architecture and for the x64 (and ARM/ARM64) architecture.

Interrupts are serviced in priority order, and a higher-priority interrupt preempts the servicing of a lower-priority interrupt. When a high-priority interrupt occurs, the processor saves the interrupted thread's state and invokes the trap dispatchers associated with the interrupt. The trap dispatcher raises the IRQL and calls the interrupt's service routine. After the service routine executes, the interrupt dispatcher lowers the processor's IRQL to where it was before the interrupt occurred and then loads the saved machine state. The interrupted thread resumes executing where it left off. When the kernel lowers the IRQL, lower-priority interrupts that were masked might materialize. If this happens, the kernel repeats the process to handle the new interrupts.

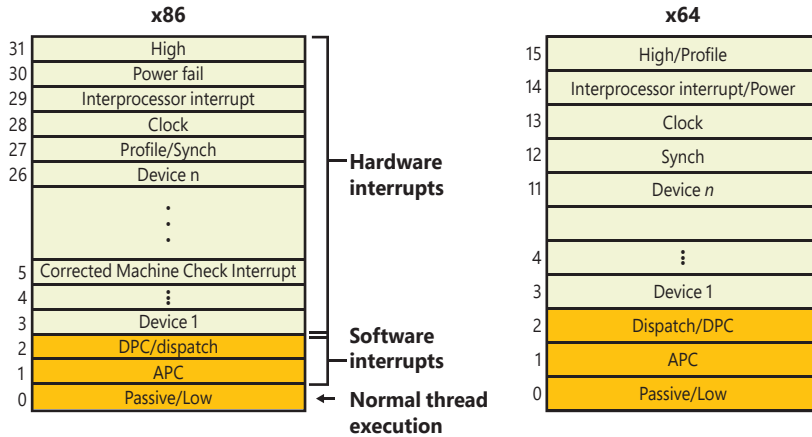

FIGURE 8-13 x86 and x64 interrupt request levels (IRQLs).

IRQL priority levels have a completely different meaning than thread-scheduling priorities (which are described in Chapter 5 of Part 1). A scheduling priority is an attribute of a thread, whereas an IRQL is an attribute of an interrupt source, such as a keyboard or a mouse. In addition, each processor has an IRQL setting that changes as operating system code executes. As mentioned earlier, on x64 systems, the IRQL is stored in the CR8 register that maps back to the TPR on the APIC.

Each processor's IRQL setting determines which interrupts that processor can receive. IRQLs are also used to synchronize access to kernel-mode data structures. (You'll find out more about synchronization later in this chapter.) As a kernel-mode thread runs, it raises or lowers the processor's IRQL directly by calling *KeRaiseIrql* and *KeLowerIrql* or, more commonly, indirectly via calls to functions that acquire kernel synchronization objects. As Figure 8-14 illustrates, interrupts from a source with an IRQL above the current level interrupt the processor, whereas interrupts from sources with IRQLs equal to or below the current level are *masked* until an executing thread lowers the IRQL.

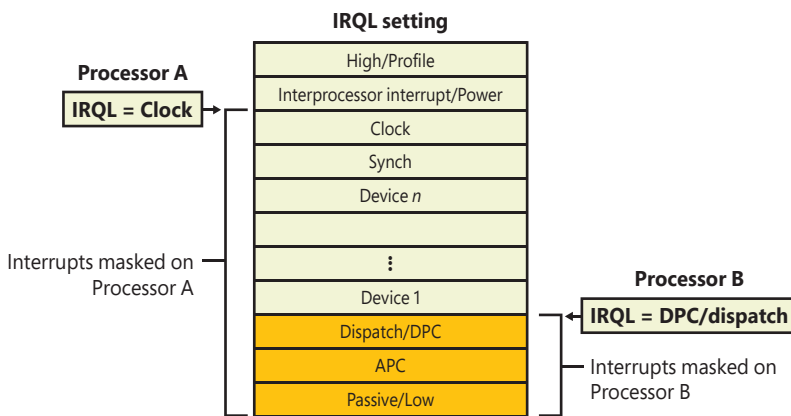

FIGURE 8-14 Masking interrupts.

A kernel-mode thread raises and lowers the IRQL of the processor on which it's running, depending on what it's trying to do. For example, when an interrupt occurs, the trap handler (or perhaps the processor, depending on its architecture) raises the processor's IRQL to the assigned IRQL of the interrupt source. This elevation masks all interrupts at and below that IRQL (on that processor only), which ensures that the processor servicing the interrupt isn't waylaid by an interrupt at the same level or a lower level. The masked interrupts are either handled by another processor or held back until the IRQL drops. Therefore, all components of the system, including the kernel and device drivers, attempt to keep the IRQL at *passive* level (sometimes called *low* level). They do this because device drivers can respond to hardware interrupts in a timelier manner if the IRQL isn't kept unnecessarily elevated for long periods. Thus, when the system is not performing any interrupt work (or needs to synchronize with it) or handling a software interrupt such as a DPC or APC, the IRQL is always 0. This obviously includes any user-mode processing because allowing user-mode code to touch the IRQL would have significant effects on system operation. In fact, returning to a user-mode thread with the IRQL above 0 results in an immediate system crash (*bugcheck*) and is a serious driver bug.

Finally, note that dispatcher operations themselves—such as context switching from one thread to another due to preemption—run at IRQL 2 (hence the name *dispatch level*), meaning that the processor behaves in a single-threaded, cooperative fashion at this level and above. It is, for example, illegal to wait on a dispatcher object (more on this in the “Synchronization” section that follows) at this IRQL, as a context switch to a different thread (or the idle thread) would never occur. Another restriction is that only nonpaged memory can be accessed at IRQL DPC/dispatch level or higher.

This rule is actually a side effect of the first restriction because attempting to access memory that isn't resident results in a page fault. When a page fault occurs, the memory manager initiates a disk I/O and then needs to wait for the file system driver to read the page in from disk. This wait would, in turn, require the scheduler to perform a context switch (perhaps to the idle thread if no user thread is waiting to run), thus violating the rule that the scheduler can't be invoked (because the IRQL is still DPC/dispatch level or higher at the time of the disk read). A further problem results in the fact that I/O completion typically occurs at APC_LEVEL, so even in cases where a wait wouldn't be required, the I/O would never complete because the completion APC would not get a chance to run.

If either of these two restrictions is violated, the system crashes with an *IRQL_NOT_LESS_OR_EQUAL* or a *DRIVER_IRQL_NOT_LESS_OR_EQUAL* crash code. (See Chapter 10, “Management, diagnostics, and tracing” for a thorough discussion of system crashes.) Violating these restrictions is a common bug in device drivers. The Windows Driver Verifier has an option you can set to assist in finding this particular type of bug.

Conversely, this also means that when working at IRQL 1 (also called *APC level*), preemption is still active and context switching can occur. This makes IRQL 1 essentially behave as a *thread-local* IRQL instead of a *processor-local* IRQL, since a wait operation or preemption operation at IRQL 1 will cause the scheduler to save the current IRQL in the thread's control block (in the *KTHREAD* structure, as seen in Chapter 5), and restore the processor's IRQL to that of the newly executed thread. This means that a thread at passive level (IRQL 0) can still preempt a thread running at APC level (IRQL 1), because below IRQL 2, the scheduler decides which thread controls the processor.

EXPERIMENT: Viewing the IRQL

You can view a processor's saved IRQL with the **!irq** debugger command. The saved IRQL represents the IRQL at the time just before the break-in to the debugger, which raises the IRQL to a static, meaningless value:

```
kd> !irq  
Debugger saved IRQL for processor 0x0 -- 0 (LOW_LEVEL)
```

Note that the IRQL value is saved in two locations. The first, which represents the current IRQL, is the processor control region (PCR), whereas its extension, the processor region control block (PRCB), contains the saved IRQL in the *DebuggerSavedIRQL* field. This trick is used because using a remote kernel debugger will raise the IRQL to *HIGH_LEVEL* to stop any and all asynchronous processor operations while the user is debugging the machine, which would cause the output of **!irq** to be meaningless. This "saved" value is thus used to indicate the IRQL right before the debugger is attached.

Each interrupt level has a specific purpose. For example, the kernel issues an *interprocessor interrupt* (IPI) to request that another processor perform an action, such as dispatching a particular thread for execution or updating its translation look-aside buffer (TLB) cache. The system clock generates an interrupt at regular intervals, and the kernel responds by updating the clock and measuring thread execution time. The HAL provides interrupt levels for use by interrupt-driven devices; the exact number varies with the processor and system configuration. The kernel uses software interrupts (described later in this chapter) to initiate thread scheduling and to asynchronously break into a thread's execution.

Mapping interrupt vectors to IRQLs

On systems without an APIC-based architecture, the mapping between the GSIV/IRQ and the IRQL had to be strict. To avoid situations where the interrupt controller might think an interrupt line is of higher priority than another, when in Windows's world, the IRQLs reflected an opposite situation. Thankfully, with APICs, Windows can easily expose the IRQL as part of the APIC's TPR, which in turn can be used by the APIC to make better delivery decisions. Further, on APIC systems, the priority of each hardware interrupt is not tied to its GSIV/IRQ, but rather to the interrupt vector: the upper 4 bits of the vector map back to the priority. Since the IDT can have up to 256 entries, this gives a space of 16 possible priorities (for example, vector 0x40 would be priority 4), which are the same 16 numbers that the TPR can hold, which map back to the same 16 IRQLs that Windows implements!

Therefore, for Windows to determine what IRQL to assign to an interrupt, it must first determine the appropriate interrupt vector for the interrupt, and program the IOAPIC to use that vector for the associated hardware GSIV. Or, conversely, if a specific IRQL is needed for a hardware device, Windows must choose an interrupt vector that maps back to that priority. These decisions are performed by the Plug and Play manager working in concert with a type of device driver called a *bus driver*, which determines the presence of devices on its bus (PCI, USB, and so on) and what interrupts can be assigned to a device.

The bus driver reports this information to the Plug and Play manager, which decides—after taking into account the acceptable interrupt assignments for all other devices—which interrupt will be assigned to each device. Then it calls a Plug and Play interrupt arbiter, which maps interrupts to IRQs. This arbiter is exposed by the HAL, which also works with the ACPI bus driver and the PCI bus driver to collectively determine the appropriate mapping. In most cases, the ultimate vector number is selected in a round-robin fashion, so there is no computable way to figure it out ahead of time. However, an experiment later in this section shows how the debugger can query this information from the interrupt arbiter.

Outside of arbitrated interrupt vectors associated with hardware interrupts, Windows also has a number of predefined interrupt vectors that are always at the same index in the IDT, which are defined in Table 8-4.

TABLE 8-4 Predefined interrupt vectors

Vector	Usage
0x1F	APC interrupt
0x2F	DPC interrupt
0x30	Hypervisor interrupt
0x31-0x34	VMbus interrupt(s)
0x35	CMCI interrupt
0xCD	Thermal interrupt
0xCE	IOMMU interrupt
0xCF	DMA interrupt
0xD1	Clock timer interrupt
0xD2	Clock IPI interrupt
0xD3	Clock always on interrupt
0xD7	Reboot Interrupt
0xD8	Stub interrupt
0xD9	Test interrupt
0xDF	Spurious interrupt
0xE1	IPI interrupt
0xE2	LAPIC error interrupt
0xE3	DRS interrupt
0xF0	Watchdog interrupt
0xFB	Hypervisor HPET interrupt
0xFD	Profile interrupt
0xFE	Performance interrupt

You'll note that the vector number's priority (recall that this is stored in the upper 4 bits, or nibble) typically matches the IRQs shown in the Figure 8-14—for example, the APC interrupt is 1, the DPC

interrupt is 2, while the IPI interrupt is 14, and the profile interrupt is 15. On this topic, let's see what the predefined IRQLs are on a modern Windows system.

Predefined IRQLs

Let's take a closer look at the use of the predefined IRQLs, starting from the highest level shown in Figure 8-13:

- The kernel typically uses *high* level only when it's halting the system in *KeBugCheckEx* and masking out all interrupts or when a remote kernel debugger is attached. The *profile* level shares the same value on non-x86 systems, which is where the profile timer runs when this functionality is enabled. The performance interrupt, associated with such features as Intel Processor Trace (Intel PT) and other hardware performance monitoring unit (PMU) capabilities, also runs at this level.
- *Interprocessor interrupt* level is used to request another processor to perform an action, such as updating the processor's TLB cache or modifying a control register on all processors. The *Deferred Recovery Service* (DRS) level also shares the same value and is used on x64 systems by the Windows Hardware Error Architecture (WHEA) for performing recovery from certain Machine Check Errors (MCE).
- *Clock* level is used for the system's clock, which the kernel uses to track the time of day as well as to measure and allot CPU time to threads.
- The *synchronization* IRQL is internally used by the dispatcher and scheduler code to protect access to global thread scheduling and wait/synchronization code. It is typically defined as the highest level right after the device IRQLs.
- The *device* IRQLs are used to prioritize device interrupts. (See the previous section for how hardware interrupt levels are mapped to IRQLs.)
- The *corrected machine check interrupt* level is used to signal the operating system after a serious but corrected hardware condition or error that was reported by the CPU or firmware through the *Machine Check Error* (MCE) interface.
- *DPC/dispatch*-level and *APC*-level interrupts are software interrupts that the kernel and device drivers generate. (DPCs and APCs are explained in more detail later in this chapter.)
- The lowest IRQL, *passive* level, isn't really an interrupt level at all; it's the setting at which normal thread execution takes place and all interrupts can occur.

Interrupt objects

The kernel provides a portable mechanism—a kernel control object called an *interrupt object*, or *KINTERRUPT*—that allows device drivers to register ISRs for their devices. An interrupt object contains all the information the kernel needs to associate a device ISR with a particular hardware interrupt, including the address of the ISR, the polarity and trigger mode of the interrupt, the IRQL at which the device interrupts, sharing state, the GSIV and other interrupt controller data, as well as a host of performance statistics.

These interrupt objects are allocated from a common pool of memory, and when a device driver registers an interrupt (with *IoConnectInterrupt* or *IoConnectInterruptEx*), one is initialized with all the necessary information. Based on the number of processors eligible to receive the interrupt (which is indicated by the device driver when specifying the *interrupt affinity*), a KINTERRUPT object is allocated for each one—in the typical case, this means for every processor on the machine. Next, once an interrupt vector has been selected, an array in the KPRCB (called *InterruptObject*) of each eligible processor is updated to point to the allocated KINTERRUPT object that's specific to it.

As the KINTERRUPT is allocated, a check is made to validate whether the chosen interrupt vector is a shareable vector, and if so, whether an existing KINTERRUPT has already claimed the vector. If yes, the kernel updates the *DispatchAddress* field (of the *KINTERRUPT* data structure) to point to the function *KiChainedDispatch* and adds this KINTERRUPT to a linked list (*InterruptListEntry*) contained in the first existing KINTERRUPT already associated with the vector. If this is an exclusive vector, on the other hand, then *KiInterruptDispatch* is used instead.

The interrupt object also stores the IRQL associated with the interrupt so that *KiInterruptDispatch* or *KiChainedDispatch* can raise the IRQL to the correct level before calling the ISR and then lower the IRQL after the ISR has returned. This two-step process is required because there's no way to pass a pointer to the interrupt object (or any other argument for that matter) on the initial dispatch because the initial dispatch is done by hardware.

When an interrupt occurs, the IDT points to one of 256 copies of the *KiIsrThunk* function, each one having a different line of assembly code that pushes the interrupt vector on the kernel stack (because this is not provided by the processor) and then calling a shared *KiIsrLinkage* function, which does the rest of the processing. Among other things, the function builds an appropriate trap frame as explained previously, and eventually calls the dispatch address stored in the KINTERRUPT (one of the two functions above). It finds the KINTERRUPT by reading the current KPRCB's *InterruptObject* array and using the interrupt vector on the stack as an index, dereferencing the matching pointer. On the other hand, if a KINTERRUPT is not present, then this interrupt is treated as an unexpected interrupt. Based on the value of the registry value *BugCheckUnexpectedInterrupts* in the HKLM\SYSTEM\CurrentControlSet\Control\Session Manager\Kernel key, the system might either crash with *KeBugCheckEx*, or the interrupt is silently ignored, and execution is restored back to the original control point.

On x64 Windows systems, the kernel optimizes interrupt dispatch by using specific routines that save processor cycles by omitting functionality that isn't needed, such as *KiInterruptDispatchNoLock*, which is used for interrupts that do not have an associated kernel-managed spinlock (typically used by drivers that want to synchronize with their ISRs), *KiInterruptDispatchNoLockNoEtw* for interrupts that do not want ETW performance tracing, and *KiSpuriousDispatchNoEOI* for interrupts that are not required to send an end-of-interrupt signal since they are spurious.

Finally, *KiInterruptDispatchNoEOI*, which is used for interrupts that have programmed the APIC in *Auto-End-of-Interrupt* (Auto-EOI) mode—because the interrupt controller will send the EOI signal automatically, the kernel does not need the extra code to perform the EOI itself. For example, many HAL interrupt routines take advantage of the “no-lock” dispatch code because the HAL does not require the kernel to synchronize with its ISR.

Another kernel interrupt handler is *KiFloatingDispatch*, which is used for interrupts that require saving the floating-point state. Unlike kernel-mode code, which typically is not allowed to use floating-point (MMX, SSE, 3DNow!) operations because these registers won't be saved across context switches, ISRs might need to use these registers (such as the video card ISR performing a quick drawing operation). When connecting an interrupt, drivers can set the *FloatingSave* argument to *TRUE*, requesting that the kernel use the floating-point dispatch routine, which will save the floating registers. (However, this greatly increases interrupt latency.) Note that this is supported only on 32-bit systems.

Regardless of which dispatch routine is used, ultimately a call to the *ServiceRoutine* field in the *KINTERRUPT* will be made, which is where the driver's ISR is stored. Alternatively, for *message signaled interrupts* (MSI), which are explained later, this is a pointer to *KiInterruptMessageDispatch*, which will then call the *MessageServiceRoutine* pointer in *KINTERRUPT* instead. Note that in some cases, such as when dealing with Kernel Mode Driver Framework (KMDF) drivers, or certain miniport drivers such as those based on NDIS or StorPort (more on driver frameworks is explained in Chapter 6 of Part 1, "I/O system"), these routines might be specific to the framework and/or port driver, which will do further processing before calling the final underlying driver.

Figure 8-15 shows typical interrupt control flow for interrupts associated with interrupt objects.

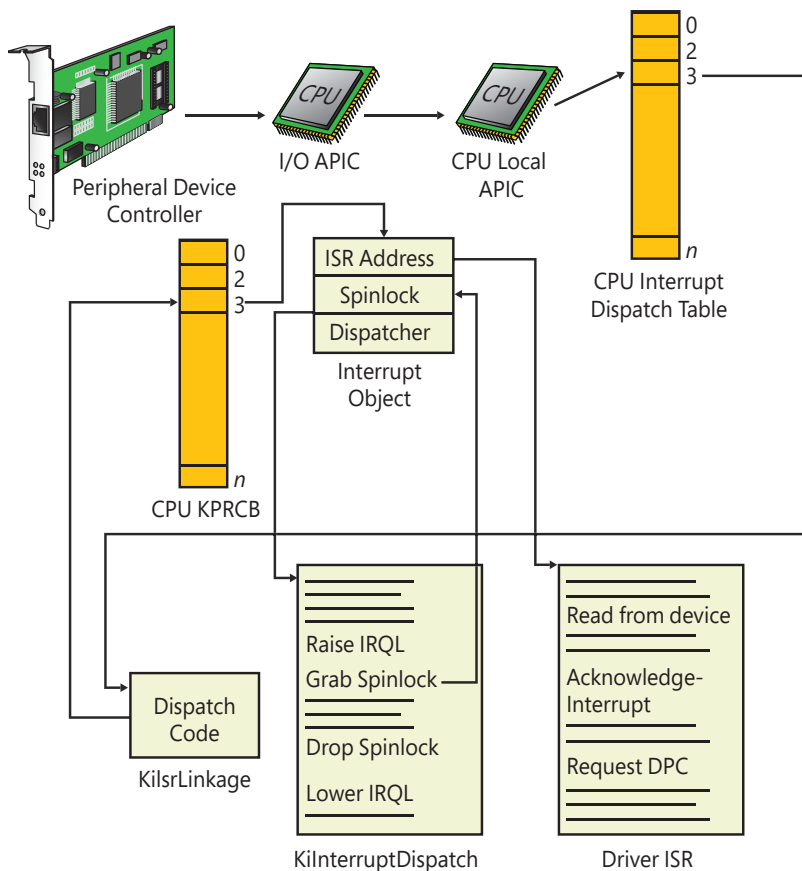

FIGURE 8-15 Typical interrupt control flow.

Associating an ISR with a particular level of interrupt is called *connecting an interrupt object*, and dissociating an ISR from an IDT entry is called *disconnecting an interrupt object*. These operations, accomplished by calling the kernel functions `IoConnectInterruptEx` and `IoDisconnectInterruptEx`, allow a device driver to “turn on” an ISR when the driver is loaded into the system and to “turn off” the ISR if the driver is unloaded.

As was shown earlier, using the interrupt object to register an ISR prevents device drivers from fiddling directly with interrupt hardware (which differs among processor architectures) and from needing to know any details about the IDT. This kernel feature aids in creating portable device drivers because it eliminates the need to code in assembly language or to reflect processor differences in device drivers. Interrupt objects provide other benefits as well. By using the interrupt object, the kernel can synchronize the execution of the ISR with other parts of a device driver that might share data with the ISR. (See Chapter 6 in Part 1 for more information about how device drivers respond to interrupts.)

We also described the concept of a *chained* dispatch, which allows the kernel to easily call more than one ISR for any interrupt level. If multiple device drivers create interrupt objects and connect them to the same IDT entry, the `KiChainedDispatch` routine calls each ISR when an interrupt occurs at the specified interrupt line. This capability allows the kernel to easily support *daisy-chain* configurations, in which several devices share the same interrupt line. The chain breaks when one of the ISRs claims ownership for the interrupt by returning a status to the interrupt dispatcher.

If multiple devices sharing the same interrupt require service at the same time, devices not acknowledged by their ISRs will interrupt the system again once the interrupt dispatcher has lowered the IRQL. Chaining is permitted only if all the device drivers wanting to use the same interrupt indicate to the kernel that they can share the interrupt (indicated by the `ShareVector` field in the `KINTERRUPT` object); if they can't, the Plug and Play manager reorganizes their interrupt assignments to ensure that it honors the sharing requirements of each.

EXPERIMENT: Examining interrupt internals

Using the kernel debugger, you can view details of an interrupt object, including its IRQL, ISR address, and custom interrupt-dispatching code. First, execute the `!idt` debugger command and check whether you can locate an entry that includes a reference to `I8042KeyboardInterruptService`, the ISR routine for the PS2 keyboard device. Alternatively, you can look for entries pointing to `Stornvme.sys` or `Scsiport.sys` or any other third-party driver you recognize. In a Hyper-V virtual machine, you may simply want to use the `Acpi.sys` entry. Here's a system with a PS2 keyboard device entry:

```
70:      fffff8045675a600 i8042prt!I8042KeyboardInterruptService (KINTERRUPT ffff8e01cbe3b280)
```

To view the contents of the interrupt object associated with the interrupt, you can simply click on the link that the debugger offers, which uses the `dt` command, or you can manually use the `dx` command as well. Here's the `KINTERRUPT` from the machine used in the experiment:

```
6: kd> dt nt!_KINTERRUPT ffff8e01cbe3b280
+0x000 Type           : 0n22
+0x002 Size           : 0n256
+0x008 InterruptListEntry : _LIST_ENTRY [ 0x00000000`00000000 - 0x00000000`00000000 ]
```

```

+0x018 ServiceRoutine      : 0xfffff804`65e56820
                             unsigned char i8042prt!I8042KeyboardInterruptService
+0x020 MessageServiceRoutine : (null)
+0x028 MessageIndex       : 0
+0x030 ServiceContext     : 0xfffffe50f`9dfe9040 Void
+0x038 SpinLock           : 0
+0x040 TickCount          : 0
+0x048 ActualLock         : 0xfffffe50f`9dfe91a0 -> 0
+0x050 DispatchAddress    : 0xfffff804`565ca320 void nt!KiInterruptDispatch+0
+0x058 Vector             : 0x70
+0x05c Irq1               : 0x7 ''
+0x05d SynchronizeIrq1   : 0x7 ''
+0x05e FloatingSave       : 0 ''
+0x05f Connected         : 0x1 ''
+0x060 Number             : 6
+0x064 ShareVector        : 0 ''
+0x065 EmulateActiveBoth  : 0 ''
+0x066 ActiveCount        : 0
+0x068 InternalState      : 0n4
+0x06c Mode                : 1 ( Latched )
+0x070 Polarity           : 0 ( InterruptPolarityUnknown )
+0x074 ServiceCount       : 0
+0x078 DispatchCount     : 0
+0x080 PassiveEvent       : (null)
+0x088 TrapFrame          : (null)
+0x090 DisconnectData    : (null)
+0x098 ServiceThread     : (null)
+0x0a0 ConnectionData     : 0xfffffe50f`9db3bd90 _INTERRUPT_CONNECTION_DATA
+0x0a8 IntTrackEntry      : 0xfffffe50f`9d091d90 Void
+0x0b0 IsrDpcStats        : _ISRDPCCSTATS
+0x0f0 RedirectObject     : (null)
+0x0f8 Padding            : [8] ""

```

In this example, the IRQ that Windows assigned to the interrupt is 7, which matches the fact that the interrupt vector is 0x70 (and hence the upper 4 bits are 7). Furthermore, you can see from the *DispatchAddress* field that this is a regular *KiInterruptDispatch*-style interrupt with no additional optimizations or sharing.

If you wanted to see which GSIV (IRQ) was associated with the interrupt, there are two ways in which you can obtain this data. First, recent versions of Windows now store this data as an *INTERRUPT_CONNECTION_DATA* structure embedded in the *ConnectionData* field of the *KINTERRUPT*, as shown in the preceding output. You can use the **dt** command to dump the pointer from your system as follows:

```

6: kd> dt 0xfffffe50f`9db3bd90 _INTERRUPT_CONNECTION_DATA Vectors[0]..
nt!_INTERRUPT_CONNECTION_DATA
+0x008 Vectors          : [0]
+0x000 Type             : 0 ( InterruptTypeControllerInput )
+0x004 Vector           : 0x70
+0x008 Irq1            : 0x7 ''
+0x00c Polarity         : 1 ( InterruptActiveHigh )
+0x010 Mode             : 1 ( Latched )
+0x018 TargetProcessors :

```

```

+0x000 Mask          : 0xff
+0x008 Group         : 0
+0x00a Reserved      : [3] 0
+0x028 IntRemapInfo :
+0x000 IrtIndex      : 0y00000000000000000000000000000000 (0)
+0x000 FlagHalInternal : 0y0
+0x000 FlagTranslated : 0y0
+0x004 u             : <anonymous-tag>
+0x038 ControllerInput :
+0x000 Gsiv          : 1

```

The *Type* indicates that this is a traditional line/controller-based input, and the *Vector* and *Irql* fields confirm earlier data seen in the KINTERRUPT already. Next, by looking at the *ControllerInput* structure, you can see that the GSIV is 1 (i.e., IRQ 1). If you'd been looking at a different kind of interrupt, such as a Message Signaled Interrupt (more on this later), you would dereference the *MessageRequest* field instead, for example.

Another way to map GSIV to interrupt vectors is to recall that Windows keeps track of this translation when managing device resources through what are called *arbiters*. For each resource type, an arbiter maintains the relationship between virtual resource usage (such as an interrupt vector) and physical resources (such as an interrupt line). As such, you can query the ACPI IRQ arbiter and obtain this mapping. Use the **!acpiirqarb** command to obtain information on the ACPI IRQ arbiter:

```

6: kd> !acpiirqarb

Processor 0 (0, 0):
Device Object: 0000000000000000
Current IDT Allocation:
...
000000070 - 000000070 D fffffe50f9959baf0 (i8042prt) A:ffffce0717950280 IRQ(GSIV):1
...

```

Note that the GSIV for the keyboard is IRQ 1, which is a legacy number from back in the IBM PC/AT days that has persisted to this day. You can also use **!arbiter 4** (4 tells the debugger to display only IRQ arbiters) to see the specific entry underneath the ACPI IRQ arbiter:

```

6: kd> !arbiter 4

DEVNODE fffffe50f97445c70 (ACPI_HAL\PNP0C08\0)
Interrupt Arbiter "ACPI_IRQ" at fffff804575415a0
Allocated ranges:
0000000000000001 - 0000000000000001 fffffe50f9959baf0 (i8042prt)

```

In this case, note that the range represents the GSIV (IRQ), not the interrupt vector. Further, note that in either output, you are given the owner of the vector, in the type of a *device object* (in this case, 0xFFFFE50F9959BAF0). You can then use the **!devobj** command to get information on the i8042prt device in this example (which corresponds to the PS/2 driver):

```

6: kd> !devobj 0xFFFFE50F9959BAF0
Device object (ffffe50f9959baf0) is for:
00000049 \Driver\ACPI DriverObject fffffe50f974356f0

```

```

Current Irp 00000000 RefCount 1 Type 00000032 Flags 00001040
SecurityDescriptor fffffe0711ebf3e0 DevExt fffffe50f995573f0 DevObjExt fffffe50f9959bc40
DevNode fffffe50f9959e670
ExtensionFlags (0x00000800) DOE_DEFAULT_SD_PRESENT
Characteristics (0x00000080) FILE_AUTOGENERATED_DEVICE_NAME
AttachedDevice (Upper) fffffe50f9dfe9040 \Driver\i8042prt
Device queue is not busy.

```

The device object is associated to a *device node*, which stores all the device's physical resources. You can now dump these resources with the **!devnode** command, and using the **0xf** flag to ask for both raw and translated resource information:

```

6: kd> !devnode fffffe50f9959e670 f
DevNode 0xfffffe50f9959e670 for PDO 0xfffffe50f9959baf0
InstancePath is "ACPI\LEN0071\4&36899b7b&0"
ServiceName is "i8042prt"
TargetDeviceNotify List - f 0xfffffce0717307b20 b 0xfffffce0717307b20
State = DeviceNodeStarted (0x308)
Previous State = DeviceNodeEnumerateCompletion (0x30d)
CmResourceList at 0xfffffce0713518330 Version 1.1 Interface 0xf Bus #0
Entry 0 - Port (0x1) Device Exclusive (0x1)
Flags (PORT_MEMORY PORT_IO 16_BIT_DECODE
Range starts at 0x60 for 0x1 bytes
Entry 1 - Port (0x1) Device Exclusive (0x1)
Flags (PORT_MEMORY PORT_IO 16_BIT_DECODE
Range starts at 0x64 for 0x1 bytes
Entry 2 - Interrupt (0x2) Device Exclusive (0x1)
Flags (LATCHED
Level 0x1, Vector 0x1, Group 0, Affinity 0xffffffff
...
TranslatedResourceList at 0xfffffce0713517bb0 Version 1.1 Interface 0xf Bus #0
Entry 0 - Port (0x1) Device Exclusive (0x1)
Flags (PORT_MEMORY PORT_IO 16_BIT_DECODE
Range starts at 0x60 for 0x1 bytes
Entry 1 - Port (0x1) Device Exclusive (0x1)
Flags (PORT_MEMORY PORT_IO 16_BIT_DECODE
Range starts at 0x64 for 0x1 bytes
Entry 2 - Interrupt (0x2) Device Exclusive (0x1)
Flags (LATCHED
Level 0x7, Vector 0x70, Group 0, Affinity 0xff

```

The device node tells you that this device has a resource list with three entries, one of which is an interrupt entry corresponding to IRQ 1. (The *level* and *vector* numbers represent the GSIV rather than the interrupt vector.) Further down, the translated resource list now indicates the IRQ as 7 (this is the *level* number) and the interrupt vector as 0x70.

On ACPI systems, you can also obtain this information in a slightly easier way by reading the extended output of the **!acpiirqarb** command introduced earlier. As part of its output, it displays the IRQ to IDT mapping table:

```

Interrupt Controller (Inputs: 0x0-0x77):
(01)Cur:IDT-70 Ref-1 Boot-0 edg hi Pos:IDT-00 Ref-0 Boot-0 lev unk
(02)Cur:IDT-80 Ref-1 Boot-1 edg hi Pos:IDT-00 Ref-0 Boot-1 lev unk
(08)Cur:IDT-90 Ref-1 Boot-0 edg hi Pos:IDT-00 Ref-0 Boot-0 lev unk

```

(09)Cur:IDT-b0 Ref-1 Boot-0 lev hi	Pos:IDT-00 Ref-0 Boot-0 lev unk
(0e)Cur:IDT-a0 Ref-1 Boot-0 lev low	Pos:IDT-00 Ref-0 Boot-0 lev unk
(10)Cur:IDT-b5 Ref-2 Boot-0 lev low	Pos:IDT-00 Ref-0 Boot-0 lev unk
(11)Cur:IDT-a5 Ref-1 Boot-0 lev low	Pos:IDT-00 Ref-0 Boot-0 lev unk
(12)Cur:IDT-95 Ref-1 Boot-0 lev low	Pos:IDT-00 Ref-0 Boot-0 lev unk
(14)Cur:IDT-64 Ref-2 Boot-0 lev low	Pos:IDT-00 Ref-0 Boot-0 lev unk
(17)Cur:IDT-54 Ref-1 Boot-0 lev low	Pos:IDT-00 Ref-0 Boot-0 lev unk
(1f)Cur:IDT-a6 Ref-1 Boot-0 lev low	Pos:IDT-00 Ref-0 Boot-0 lev unk
(41)Cur:IDT-96 Ref-1 Boot-0 edg hi	Pos:IDT-00 Ref-0 Boot-0 lev unk

As expected, IRQ 1 is associated with IDT entry 0x70. For more information on device objects, resources, and other related concepts, see Chapter 6 in Part 1.

Line-based versus message signaled–based interrupts

Shared interrupts are often the cause of high interrupt latency and can also cause stability issues. They are typically undesirable and a side effect of the limited number of physical interrupt lines on a computer. For example, in the case of a 4-in-1 media card reader that can handle USB, Compact Flash, Sony Memory Stick, Secure Digital, and other formats, all the controllers that are part of the same physical device would typically be connected to a single interrupt line, which is then configured by the different device drivers as a shared interrupt vector. This adds latency as each one is called in a sequence to determine the actual controller that is sending the interrupt for the media device.

A much better solution is for each device controller to have its own interrupt and for one driver to manage the different interrupts, knowing which device they came from. However, consuming four traditional IRQ lines for a single device quickly leads to IRQ line exhaustion. Additionally, PCI devices are each connected to only one IRQ line anyway, so the media card reader cannot use more than one IRQ in the first place even if it wanted to.

Other problems with generating interrupts through an IRQ line is that incorrect management of the IRQ signal can lead to interrupt storms or other kinds of deadlocks on the machine because the signal is driven “high” or “low” until the ISR acknowledges it. (Furthermore, the interrupt controller must typically receive an EOI signal as well.) If either of these does not happen due to a bug, the system can end up in an interrupt state forever, further interrupts could be masked away, or both. Finally, line-based interrupts provide poor scalability in multiprocessor environments. In many cases, the hardware has the final decision as to which processor will be interrupted out of the possible set that the Plug and Play manager selected for this interrupt, and device drivers can do little about it.

A solution to all these problems was first introduced in the PCI 2.2 standard called *message-signaled interrupts (MSI)*. Although it was an optional component of the standard that was seldom found in client machines (and mostly found on servers for network card and storage controller performance), most modern systems, thanks to PCI Express 3.0 and later, fully embrace this model. In the MSI world, a device delivers a message to its driver by writing to a specific memory address over the PCI bus; in fact, this is essentially treated like a Direct Memory Access (DMA) operation as far as hardware is concerned. This action causes an interrupt, and Windows then calls the ISR with the message content (value) and

the address where the message was delivered. A device can also deliver multiple messages (up to 32) to the memory address, delivering different payloads based on the event.

For even more performance and latency-sensitive systems, MSI-X, an extension to the MSI model, which is introduced in PCI 3.0, adds support for 32-bit messages (instead of 16-bit), a maximum of 2048 different messages (instead of just 32), and more importantly, the ability to use a different address (which can be dynamically determined) for each of the MSI payloads. Using a different address allows the MSI payload to be written to a different physical address range that belongs to a different processor, or a different set of target processors, effectively enabling nonuniform memory access (NUMA)-aware interrupt delivery by sending the interrupt to the processor that initiated the related device request. This improves latency and scalability by monitoring both load and the closest NUMA node during interrupt completion.

In either model, because communication is based across a memory value, and because the content is delivered with the interrupt, the need for IRQ lines is removed (making the total system limit of MSIs equal to the number of interrupt vectors, not IRQ lines), as is the need for a driver ISR to query the device for data related to the interrupt, decreasing latency. Due to the large number of device interrupts available through this model, this effectively nullifies any benefit of sharing interrupts, decreasing latency further by directly delivering the interrupt data to the concerned ISR.

This is also one of the reasons why you've seen this text, as well as most of the debugger commands, utilize the term "GSIV" instead of IRQ because it more generically describes an MSI vector (which is identified by a negative number), a traditional IRQ-based line, or even a General Purpose Input Output (GPIO) pin on an embedded device. And, additionally, on ARM and ARM64 systems, neither of these models are used, and a Generic Interrupt Controller, or GIC, architecture is leveraged instead. In Figure 8-16, you can see the Device Manager on two computer systems showing both traditional IRQ-based GSIV assignments, as well as MSI values, which are negative.

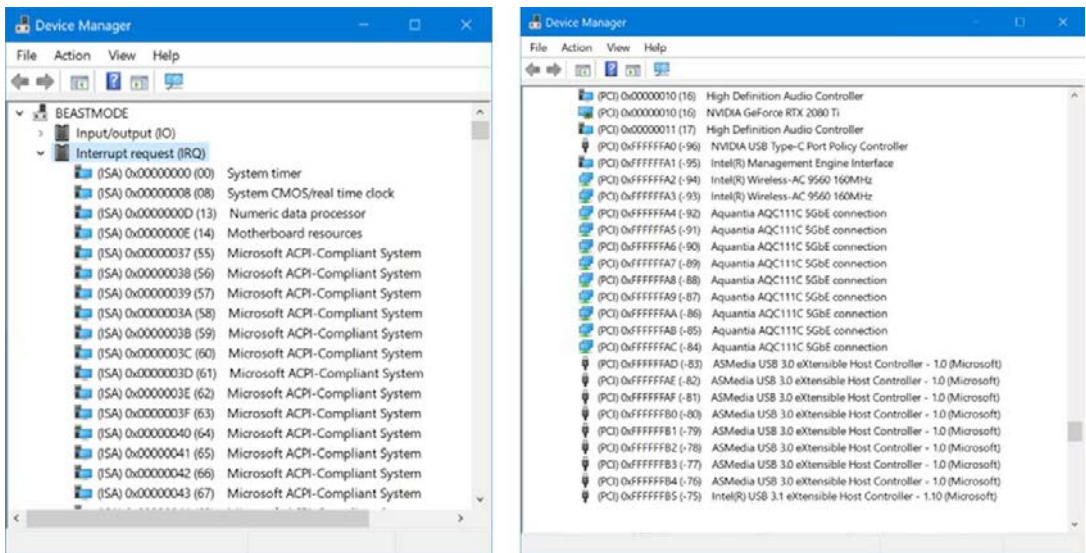

FIGURE 8-16 IRQ and MSI-based GSIV assignment.

Interrupt steering

On client (that is, excluding Server SKUs) systems that are not running virtualized, and which have between 2 and 16 processors in a single processor group, Windows enables a piece of functionality called *interrupt steering* to help with power and latency needs on modern consumer systems. Thanks to this feature, interrupt load can be spread across processors as needed to avoid bottlenecking a single CPU, and the core parking engine, which was described in Chapter 6 of Part 1, can also steer interrupts *away* from parked cores to avoid interrupt distribution from keeping too many processors awake at the same time.

Interrupt steering capabilities are dependent on interrupt controllers— for example, on ARM systems with a GIC, both level sensitive and edge (latched) triggered interrupts can be steered, whereas on APIC systems (unless running under Hyper-V), only level-sensitive interrupts can be steered. Unfortunately, because MSIs are always level edge-triggered, this would reduce the benefits of the technology, which is why Windows also implements an additional *interrupt redirection* model to handle these situations.

When *steering* is enabled, the interrupt controller is simply reprogrammed to deliver the GSIV to a different processor's LAPIC (or equivalent in the ARM GIC world). When *redirection* must be used, then all processors are delivery targets for the GSIV, and whichever processor received the interrupt manually issues an IPI to the target processor to which the interrupt should be steered toward.

Outside of the core parking engine's use of interrupt steering, Windows also exposes the functionality through a system information class that is handled by *KeIntSteerAssignCpuSetForG Siv* as part of the Real-Time Audio capabilities of Windows 10 and the CPU Set feature that was described in the "Thread scheduling" section in Chapter 4 of Part 1. This allows a particular GSIV to be steered to a specific group of processors that can be chosen by the user-mode application, as long as it has the *Increase Base Priority* privilege, which is normally only granted to administrators or local service accounts.

Interrupt affinity and priority

Windows enables driver developers and administrators to somewhat control the processor affinity (selecting the processor or group of processors that receives the interrupt) and affinity policy (selecting how processors will be chosen and which processors in a group will be chosen). Furthermore, it enables a primitive mechanism of interrupt prioritization based on IRQ selection. Affinity policy is defined according to Table 8-5, and it's configurable through a registry value called *InterruptPolicyValue* in the Interrupt Management\Affinity Policy key under the device's instance key in the registry. Because of this, it does not require any code to configure—an administrator can add this value to a given driver's key to influence its behavior. Interrupt affinity is documented on Microsoft Docs at <https://docs.microsoft.com/en-us/windows-hardware/drivers/kernel/interrupt-affinity-and-priority>.

TABLE 8-5 IRQ affinity policies

Policy	Meaning
<i>IrqPolicyMachineDefault</i>	The device does not require a particular affinity policy. Windows uses the default machine policy, which (for machines with less than eight logical processors) is to select any available processor on the machine.
<i>IrqPolicyAllCloseProcessors</i>	On a NUMA machine, the Plug and Play manager assigns the interrupt to all the processors that are close to the device (on the same node). On non-NUMA machines, this is the same as <i>IrqPolicyAllProcessorsInMachine</i> .
<i>IrqPolicyOneCloseProcessor</i>	On a NUMA machine, the Plug and Play manager assigns the interrupt to one processor that is close to the device (on the same node). On non-NUMA machines, the chosen processor will be any available processor on the system.
<i>IrqPolicyAllProcessorsInMachine</i>	The interrupt is processed by any available processor on the machine.
<i>IrqPolicySpecifiedProcessors</i>	The interrupt is processed only by one of the processors specified in the affinity mask under the AssignmentSetOverride registry value.
<i>IrqPolicySpreadMessagesAcrossAllProcessors</i>	Different message-signaled interrupts are distributed across an optimal set of eligible processors, keeping track of NUMA topology issues, if possible. This requires MSI-X support on the device and platform.
<i>IrqPolicyAllProcessorsInGroupWhenSteered</i>	The interrupt is subject to <i>interrupt steering</i> , and as such, the interrupt should be assigned to all processor IDTs as the target processor will be dynamically selected based on steering rules.

Other than setting this affinity policy, another registry value can also be used to set the interrupt's priority, based on the values in Table 8-6.

TABLE 8-6 IRQ priorities

Priority	Meaning
<i>IrqPriorityUndefined</i>	No particular priority is required by the device. It receives the default priority (<i>IrqPriorityNormal</i>).
<i>IrqPriorityLow</i>	The device can tolerate high latency and should receive a lower IRQL than usual (3 or 4).
<i>IrqPriorityNormal</i>	The device expects average latency. It receives the default IRQL associated with its interrupt vector (5 to 11).
<i>IrqPriorityHigh</i>	The device requires as little latency as possible. It receives an elevated IRQL beyond its normal assignment (12).

As discussed earlier, it is important to note that Windows is not a real-time operating system, and as such, these IRQ priorities are hints given to the system that control only the IRQL associated with the interrupt and provide no extra priority other than the Windows IRQL priority-scheme mechanism. Because the IRQ priority is also stored in the registry, administrators are free to set these values for drivers should there be a requirement of lower latency for a driver not taking advantage of this feature.

Software interrupts

Although hardware generates most interrupts, the Windows kernel also generates software interrupts for a variety of tasks, including these:

- Initiating thread dispatching
- Non-time-critical interrupt processing
- Handling timer expiration
- Asynchronously executing a procedure in the context of a particular thread
- Supporting asynchronous I/O operations

These tasks are described in the following subsections.

Dispatch or deferred procedure call (DPC) interrupts

A DPC is typically an interrupt-related function that performs a processing task after all device interrupts have already been handled. The functions are called *deferred* because they might not execute immediately. The kernel uses DPCs to process timer expiration (and release threads waiting for the timers) and to reschedule the processor after a thread's quantum expires (note that this happens at DPC IRQL but not really through a regular kernel DPC). Device drivers use DPCs to process interrupts and perform actions not available at higher IRQLs. To provide timely service for hardware interrupts, Windows—with the cooperation of device drivers—attempts to keep the IRQL below device IRQL levels. One way that this goal is achieved is for device driver ISRs to perform the minimal work necessary to acknowledge their device, save volatile interrupt state, and defer data transfer or other less time-critical interrupt processing activity for execution in a DPC at DPC/dispatch IRQL. (See Chapter 6 in Part 1 for more information on the I/O system.)

In the case where the IRQL is passive or at APC level, DPCs will immediately execute and block all other non-hardware-related processing, which is why they are also often used to force immediate execution of high-priority system code. Thus, DPCs provide the operating system with the capability to generate an interrupt and execute a system function in kernel mode. For example, when a thread can no longer continue executing, perhaps because it has terminated or because it voluntarily enters a wait state, the kernel calls the dispatcher directly to perform an immediate context switch. Sometimes, however, the kernel detects that rescheduling should occur when it is deep within many layers of code. In this situation, the kernel requests dispatching but defers its occurrence until it completes its current activity. Using a DPC software interrupt is a convenient way to achieve this delayed processing.

The kernel always raises the processor's IRQL to DPC/dispatch level or above when it needs to synchronize access to scheduling-related kernel structures. This disables additional software interrupts and thread dispatching. When the kernel detects that dispatching should occur, it requests a DPC/dispatch-level interrupt; but because the IRQL is at or above that level, the processor holds the interrupt in check. When the kernel completes its current activity, it sees that it will lower the IRQL below DPC/dispatch level and checks to see whether any dispatch interrupts are pending. If there are, the IRQL drops to DPC/dispatch level, and the dispatch interrupts are processed. Activating the thread dispatcher by

using a software interrupt is a way to defer dispatching until conditions are right. A DPC is represented by a *DPC object*, a kernel control object that is not visible to user-mode programs but is visible to device drivers and other system code. The most important piece of information the DPC object contains is the address of the system function that the kernel will call when it processes the DPC interrupt. DPC routines that are waiting to execute are stored in kernel-managed queues, one per processor, called *DPC queues*. To request a DPC, system code calls the kernel to initialize a DPC object and then places it in a DPC queue.

By default, the kernel places DPC objects at the end of one of two DPC queues belonging to the processor on which the DPC was requested (typically the processor on which the ISR executed). A device driver can override this behavior, however, by specifying a DPC priority (low, medium, medium-high, or high, where medium is the default) and by targeting the DPC at a particular processor. A DPC aimed at a specific CPU is known as a *targeted DPC*. If the DPC has a high priority, the kernel inserts the DPC object at the front of the queue; otherwise, it is placed at the end of the queue for all other priorities.

When the processor's IRQL is about to drop from an IRQL of DPC/dispatch level or higher to a lower IRQL (APC or passive level), the kernel processes DPCs. Windows ensures that the IRQL remains at DPC/dispatch level and pulls DPC objects off the current processor's queue until the queue is empty (that is, the kernel "drains" the queue), calling each DPC function in turn. Only when the queue is empty will the kernel let the IRQL drop below DPC/dispatch level and let regular thread execution continue. DPC processing is depicted in Figure 8-17.

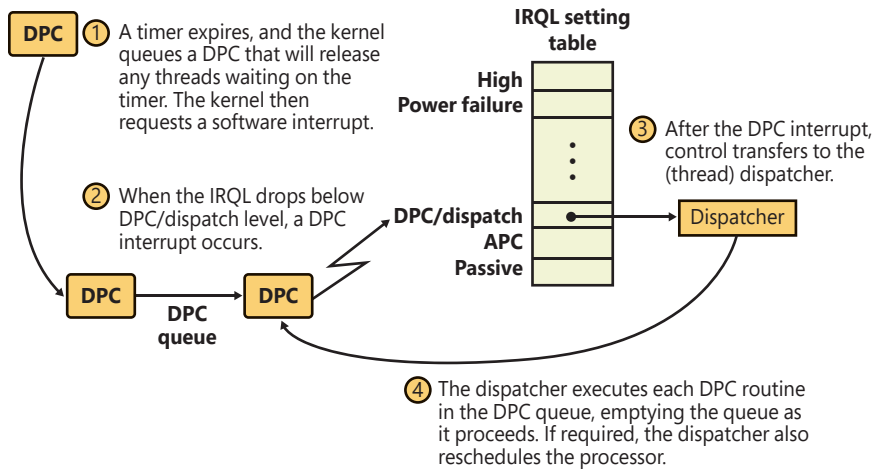

FIGURE 8-17 Delivering a DPC.

DPC priorities can affect system behavior another way. The kernel usually initiates DPC queue draining with a DPC/dispatch-level interrupt. The kernel generates such an interrupt only if the DPC is directed at the current processor (the one on which the ISR executes) and the DPC has a priority higher than low. If the DPC has a low priority, the kernel requests the interrupt only if the number of outstanding DPC requests (stored in the *DpcQueueDepth* field of the KPRCB) for the processor rises above a threshold (called *MaximumDpcQueueDepth* in the KPRCB) or if the number of DPCs requested on the processor within a time window is low.

If a DPC is targeted at a CPU different from the one on which the ISR is running and the DPC's priority is either high or medium-high, the kernel immediately signals the target CPU (by sending it a dispatch IPI) to drain its DPC queue, but only as long as the target processor is idle. If the priority is medium or low, the number of DPCs queued on the target processor (this being the *DpcQueueDepth* again) must exceed a threshold (the *MaximumDpcQueueDepth*) for the kernel to trigger a DPC/dispatch interrupt. The system idle thread also drains the DPC queue for the processor it runs on. Although DPC targeting and priority levels are flexible, device drivers rarely need to change the default behavior of their DPC objects. Table 8-7 summarizes the situations that initiate DPC queue draining. Medium-high and high appear, and are, in fact, equal priorities when looking at the generation rules. The difference comes from their insertion in the list, with high interrupts being at the head and medium-high interrupts at the tail.

TABLE 8-7 DPC interrupt generation rules

DPC Priority	DPC Targeted at ISR's Processor	DPC Targeted at Another Processor
Low	DPC queue length exceeds maximum DPC queue length, or DPC request rate is less than minimum DPC request rate	DPC queue length exceeds maximum DPC queue length, or system is idle
Medium	Always	DPC queue length exceeds maximum DPC queue length, or system is idle
Medium-High	Always	Target processor is idle
High	Always	Target processor is idle

Additionally, Table 8-8 describes the various DPC adjustment variables and their default values, as well as how they can be modified through the registry. Outside of the registry, these values can also be set by using the *SystemDpcBehaviorInformation* system information class.

TABLE 8-8 DPC interrupt generation variables

Variable	Definition	Default	Override Value
KiMaximumDpcQueueDepth	Number of DPCs queued before an interrupt will be sent even for Medium or below DPCs	4	DpcQueueDepth
KiMinimumDpcRate	Number of DPCs per clock tick where low DPCs will not cause a local interrupt to be generated	3	MinimumDpcRate
KiIdealDpcRate	Number of DPCs per clock tick before the maximum DPC queue depth is decremented if DPCs are pending but no interrupt was generated	20	IdealDpcRate
KiAdjustDpcThreshold	Number of clock ticks before the maximum DPC queue depth is incremented if DPCs aren't pending	20	AdjustDpcThreshold

Because user-mode threads execute at low IRQL, the chances are good that a DPC will interrupt the execution of an ordinary user's thread. DPC routines execute without regard to what thread is running, meaning that when a DPC routine runs, it can't assume what process address space is currently mapped. DPC routines can call kernel functions, but they can't call system services, generate page faults, or create or wait for dispatcher objects (explained later in this chapter). They can, however, access nonpaged system memory addresses, because system address space is always mapped regardless of what the current process is.

Because all user-mode memory is pageable and the DPC executes in an arbitrary process context, DPC code should never access user-mode memory in any way. On systems that support Supervisor Mode Access Protection (SMAP) or Privileged Access Neven (PAN), Windows activates these features for the duration of the DPC queue processing (and routine execution), ensuring that any user-mode memory access will immediately result in a bugcheck.

Another side effect of DPCs interrupting the execution of threads is that they end up “stealing” from the run time of the thread; while the scheduler thinks that the current thread is executing, a DPC is executing instead. In Chapter 4, Part 1, we discussed mechanisms that the scheduler uses to make up for this lost time by tracking the precise number of CPU cycles that a thread has been running and deducting DPC and ISR time, when applicable.

While this ensures the thread isn’t penalized in terms of its quantum, it does still mean that from the user’s perspective, the *wall time* (also sometimes called *clock time*—the real-life passage of time) is still being spent on something else. Imagine a user currently streaming their favorite song off the Internet: If a DPC were to take 2 seconds to run, those 2 seconds would result in the music skipping or repeating in a small loop. Similar impacts can be felt on video streaming or even keyboard and mouse input. Because of this, DPCs are a primary cause for perceived system unresponsiveness of client systems or workstation workloads because even the highest-priority thread will be interrupted by a running DPC. For the benefit of drivers with long-running DPCs, Windows supports *threaded DPCs*. Threaded DPCs, as their name implies, function by executing the DPC routine at passive level on a real-time priority (priority 31) thread. This allows the DPC to preempt most user-mode threads (because most application threads don’t run at real-time priority ranges), but it allows other interrupts, nonthreaded DPCs, APCs, and other priority 31 threads to preempt the routine.

The threaded DPC mechanism is enabled by default, but you can disable it by adding a DWORD value named *ThreadDpcEnable* in the HKEY_LOCAL_MACHINE\System\CurrentControlSet\Control\Session Manager\Kernel key, and setting it to 0. A threaded DPC must be initialized by a developer through the *KeInitializeThreadedDpc* API, which sets the DPC internal type to *ThreadedDpcObject*. Because threaded DPCs can be disabled, driver developers who make use of threaded DPCs must write their routines following the same rules as for nonthreaded DPC routines and cannot access paged memory, perform dispatcher waits, or make assumptions about the IRQL level at which they are executing. In addition, they must not use the *KeAcquire/ReleaseSpinLockAtDpcLevel* APIs because the functions assume the CPU is at dispatch level. Instead, threaded DPCs must use *KeAcquire/ReleaseSpinLockForDpc*, which performs the appropriate action after checking the current IRQL.

While threaded DPCs are a great feature for driver developers to protect the system’s resources when possible, they are an opt-in feature—both from the developer’s point of view and even the system administrator. As such, the vast majority of DPCs still execute nonthreaded and can result in perceived system lag. Windows employs a vast arsenal of performance tracking mechanisms to diagnose and assist with DPC-related issues. The first of these, of course, is to track DPC (and ISR) time both through performance counters, as well as through precise ETW tracing.

EXPERIMENT: Monitoring DPC activity

You can use Process Explorer to monitor DPC activity by opening the System Information dialog box and switching to the CPU tab, where it lists the number of interrupts and DPCs executed each time Process Explorer refreshes the display (1 second by default):

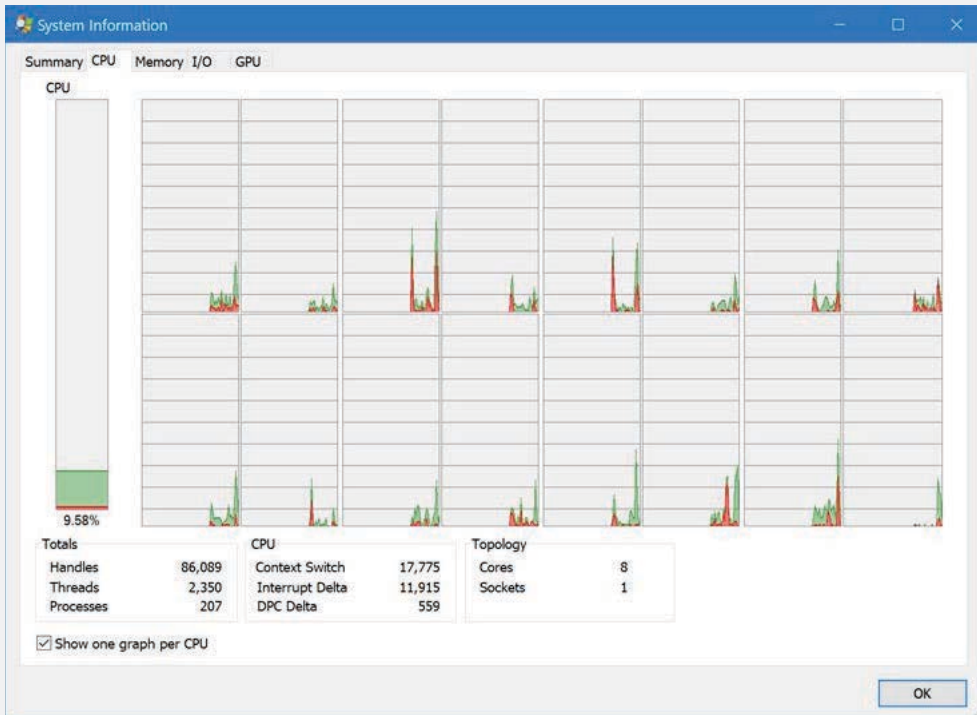

Process Explorer - Sysinternals: www.sysinternals.com [BEASTMODE\alice]

Process	CPU	Private Bytes	Working Set	PID	Description
System Idle Process	93.68	60 K	8 K	0	
System	0.26	44 K	1,920 K	4	
Interrupts	0.28	0 K	0 K	n/a	Hardware Interrupts and DPCs
smss.exe		1,088 K	1,244 K	604	
Memory Compressi...		672 K	45,336 K	3148	
csrss.exe	< 0.01	2,128 K	5,064 K	888	
wininit.exe		1,416 K	6,248 K	992	

CPU Usage: 6.32% Commit Charge: 24.74% Processes: 233 Physical Usage: 34.02%

You can also use the kernel debugger to investigate the various fields in the KPRCB that start with *Dpc*, such as *DpcRequestRate*, *DpcLastCount*, *DpcTime*, and *DpcData* (which contains the *DpcQueueDepth* and *DpcCount* for both nonthreaded and threaded DPCs). Additionally, newer versions of Windows also include an *IsrDpcStats* field that is a pointer to an *_ISRDPSTATS* structure that is present in the public symbol files. For example, the following command will show you the total number of DPCs that have been queued on the current KPRCB (both threaded and nonthreaded) versus the number that have *executed*:

```
1kd> dx new { QueuedDpcCount = @$prcb->DpcData[0].DpcCount + @$prcb->DpcData[1].DpcCount,
ExecutedDpcCount = ((nt!_ISRDPSTATS*)@$prcb->IsrDpcStats)->DpcCount },d
QueuedDpcCount : 3370380
ExecutedDpcCount : 1766914 [Type: unsigned __int64]
```

The discrepancy you see in the example output is expected; drivers might have queued a DPC that was already in the queue, a condition that Windows handles safely. Additionally, a DPC initially queued for a specific processor (but not targeting any specific one), may in some cases execute on a different processor, such as when the driver uses *KeSetTargetProcessorDpc* (the API allows a driver to *target* the DPC to a particular processor.)

Windows doesn't just expect users to manually look into latency issues caused by DPCs; it also includes built-in mechanisms to address a few common scenarios that can cause significant problems. The first is the DPC Watchdog and DPC Timeout mechanism, which can be configured through certain registry values in `HKEY_LOCAL_MACHINE\SYSTEM\CurrentControlSet\Control\Session Manager\Kernel` such as *DPCTimeout*, *DpcWatchdogPeriod*, and *DpcWatchdogProfileOffset*.

The DPC Watchdog is responsible for monitoring *all* execution of code at *DISPATCH_LEVEL* or above, where a drop in IRQL has not been registered for quite some time. The DPC Timeout, on the other hand, monitors the execution time of a specific DPC. By default, a specific DPC times out after 20 seconds, and all *DISPATCH_LEVEL* (and above) execution times out after 2 minutes. Both limits are configurable with the registry values mentioned earlier (*DPCTimeout* controls a specific DPC time limit, whereas the *DpcWatchdogPeriod* controls the combined execution of all the code running at high IRQL). When these thresholds are hit, the system will either bugcheck with *DPC_WATCHDOG_VIOLATION* (indicating which of the situations was encountered), or, if a kernel debugger is attached, raise an assertion that can be continued.

Driver developers who want to do their part in avoiding these situations can use the *KeQueryDpcWatchdogInformation* API to see the current values configured and the time remaining. Furthermore, the *KeShouldYieldProcessor* API takes these values (and other system state values) into consideration and returns to the driver a hint used for making a decision whether to continue its DPC work later, or if possible, drop the IRQL back to *PASSIVE_LEVEL* (in the case where a DPC wasn't executing, but the driver was holding a lock or synchronizing with a DPC in some way).

On the latest builds of Windows 10, each PRCB also contains a DPC Runtime History Table (*DpcRuntimeHistoryHashTable*), which contains a hash table of buckets tracking specific DPC callback functions that have recently executed and the amount of CPU cycles that they spent running. When

analyzing a memory dump or remote system, this can be useful in figuring out latency issues without access to a UI tool, but more importantly, this data is also now used by the kernel.

When a driver developer queues a DPC through *KeInsertQueueDpc*, the API will enumerate the processor's table and check whether this DPC has been seen executing before with a particularly long runtime (a default of 100 microseconds but configurable through the *LongDpcRuntimeThreshold* registry value in HKEY_LOCAL_MACHINE\SYSTEM\CurrentControlSet\Control\Session Manager\Kernel). If this is the case, the *LongDpcPresent* field will be set in the *DpcData* structure mentioned earlier.

For each idle thread (See Part 1, Chapter 4 for more information on thread scheduling and the idle thread), the kernel now also creates a DPC Delegate Thread. These are highly unique threads that belong to the System Idle Process—just like Idle Threads—and are never part of the scheduler's default thread selection algorithms. They are merely kept in the back pocket of the kernel for its own purposes. Figure 8-18 shows a system with 16 logical processors that now has 16 idle threads as well as 16 DPC delegate threads. Note that in this case, these threads have a real Thread ID (TID), and the Processor column should be treated as such for them.

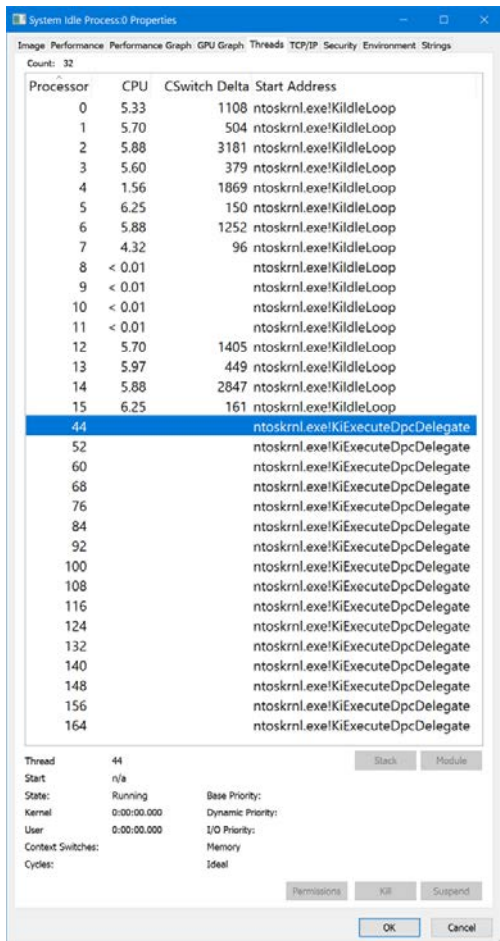

FIGURE 8-18 The DPC delegate threads on a 16-CPU system.

Whenever the kernel is dispatching DPCs, it checks whether the DPC queue depth has passed the threshold of such *long-running* DPCs (this defaults to 2 but is also configurable through the same registry key we've shown a few times). If this is the case, a decision is made to try to mitigate the issue by looking at the properties of the currently executing thread: Is it idle? Is it a real-time thread? Does its affinity mask indicate that it typically runs on a different processor? Depending on the results, the kernel may decide to schedule the DPC delegate thread instead, essentially swapping the DPC from its thread-starving position into a dedicated thread, which has the highest priority possible (still executing at *DISPATCH_LEVEL*). This gives a chance to the old preempted thread (or any other thread in the standby list) to be rescheduled to some other CPU.

This mechanism is similar to the Threaded DPCs we explained earlier, with some exceptions. The delegate thread still runs at *DISPATCH_LEVEL*. Indeed, when it is created and started in phase 1 of the NT kernel initialization (see Chapter 12 for more details), it raises its own IRQL to *DISPATCH level*, saves it in the *WaitIrql* field of its kernel thread data structure, and voluntarily asks the scheduler to perform a context switch to another standby or ready thread (via the *KiSwapThread* routine.) Thus, the delegate DPCs provide an automatic balancing action that the system takes, instead of an opt-in that driver developers must judiciously leverage on their own.

If you have a newer Windows 10 system with this capability, you can run the following command in the kernel debugger to take a look at how often the delegate thread was needed, which you can infer from the amount of context switches that have occurred since boot:

```

!kd> dx @$cursession.Processes[0].Threads.Where(t => t.KernelObject.ThreadName->
ToDisplayString().Contains("DPC Delegate Thread")).Select(t => t.KernelObject.Tcb.
ContextSwitches),d
    [44]           : 2138 [Type: unsigned long]
    [52]           : 4 [Type: unsigned long]
    [60]           : 11 [Type: unsigned long]
    [68]           : 6 [Type: unsigned long]
    [76]           : 13 [Type: unsigned long]
    [84]           : 3 [Type: unsigned long]
    [92]           : 16 [Type: unsigned long]
    [100]          : 19 [Type: unsigned long]
    [108]          : 2 [Type: unsigned long]
    [116]          : 1 [Type: unsigned long]
    [124]          : 2 [Type: unsigned long]
    [132]          : 2 [Type: unsigned long]
    [140]          : 3 [Type: unsigned long]
    [148]          : 2 [Type: unsigned long]
    [156]          : 1 [Type: unsigned long]
    [164]          : 1 [Type: unsigned long]

```

Asynchronous procedure call interrupts

Asynchronous procedure calls (APCs) provide a way for user programs and system code to execute in the context of a particular user thread (and hence a particular process address space). Because APCs are queued to execute in the context of a particular thread, they are subject to thread scheduling rules and do not operate within the same environment as DPCs—namely, they do not operate at *DISPATCH_LEVEL* and can be preempted by higher priority threads, perform blocking waits, and access pageable memory.

That being said, because APCs are still a type of software *interrupt*, they must somehow still be able to wrangle control away from the thread's primary execution path, which, as shown in this section, is in part done by operating at a specific IRQL called *APC_LEVEL*. This means that although APCs don't operate under the same restrictions as a DPC, there are still certain limitations imposed that developers must be wary of, which we'll cover shortly.

APCs are described by a kernel control object, called an *APC object*. APCs waiting to execute reside in one of two kernel-managed *APC queues*. Unlike the DPC queues, which are per-processor (and divided into threaded and nonthreaded), the APC queues are per-thread—with each thread having two APC queues: one for kernel APCs and one for user APCs.

When asked to queue an APC, the kernel looks at the *mode* (user or kernel) of the APC and then inserts it into the appropriate queue belonging to the thread that will execute the APC routine. Before looking into how and when this APC will execute, let's look at the differences between the two modes. When an APC is queued against a thread, that thread may be in one of the three following situations:

- The thread is currently running (and may even be the current thread).
- The thread is currently waiting.
- The thread is doing something else (ready, standby, and so on).

First, you might recall from Part 1, Chapter 4, "Thread scheduling," that a thread has an *alertable* state whenever performing a wait. Unless APCs have been completely disabled for a thread, for *kernel* APCs, this state is ignored—the APC always aborts the wait, with consequences that will be explained later in this section. For *user* APCs however, the thread is interrupted only if the wait was alertable and instantiated on behalf of a user-mode component or if there are other pending user APCs that already started aborting the wait (which would happen if there were lots of processors trying to queue an APC to the same thread).

User APCs also never interrupt a thread that's already running in user mode; the thread needs to either perform an alertable wait or go through a ring transition or context switch that revisits the User APC queue. Kernel APCs, on the other hand, request an interrupt on the processor of the target thread, raising the IRQL to *APC_LEVEL*, notifying the processor that it must look at the kernel APC queue of its currently running thread. And, in both scenarios, if the thread was doing "something else," some transition that takes it into either the running or waiting state needs to occur. As a practical result of this, suspended threads, for example, don't execute APCs that are being queued to them.

We mentioned that APCs could be disabled for a thread, outside of the previously described scenarios around alertability. Kernel and driver developers can choose to do so through two mechanisms, one being to simply keep their IRQL at *APC_LEVEL* or above while executing some piece of code. Because the thread is in a running state, an interrupt is normally delivered, but as per the IRQL rules we've explained, if the processor is already at *APC_LEVEL* (or higher), the interrupt is masked out. Therefore, it is only once the IRQL has dropped to *PASSIVE_LEVEL* that the pending interrupt is delivered, causing the APC to execute.

The second mechanism, which is strongly preferred because it avoids changing interrupt controller state, is to use the kernel API *KeEnterGuardedRegion*, pairing it with *KeLeaveGuardedRegion* when you want to restore APC delivery back to the thread. These APIs are recursive and can be called multiple times in a nested fashion. It is safe to context switch to another thread while still in such a region because the state updates a field in the thread object (KTHREAD) structure—*SpecialApcDisable* and not per-processor state.

Similarly, context switches can occur while at *APC_LEVEL*, even though this is per-processor state. The dispatcher saves the IRQL in the KTHREAD using the field *WaitIrql* and then sets the processor IRQL to the *WaitIrql* of the new incoming thread (which could be *PASSIVE_LEVEL*). This creates an interesting scenario where technically, a *PASSIVE_LEVEL* thread can preempt an *APC_LEVEL* thread. Such a possibility is common and entirely normal, proving that when it comes to thread execution, the scheduler outweighs any IRQL considerations. It is only by raising to *DISPATCH_LEVEL*, which disables thread preemption, that IRQLs supersede the scheduler. Since *APC_LEVEL* is the only IRQL that ends up behaving this way, it is often called a *thread-local IRQL*, which is not entirely accurate but is a sufficient approximation for the behavior described herein.

Regardless of how APCs are disabled by a kernel developer, one rule is paramount: Code can neither return to user mode with the APC at anything above *PASSIVE_LEVEL* nor can *SpecialApcDisable* be set to anything but 0. Such situations result in an immediate bugcheck, typically meaning some driver has forgotten to release a lock or leave its guarded region.

In addition to two APC *modes*, there are two *types* of APCs for each mode—normal APCs and special APCs—both of which behave differently depending on the mode. We describe each combination:

- **Special Kernel APC** This combination results in an APC that is always inserted at the tail of all other existing special kernel APCs in the APC queue but before any normal kernel APCs. The *kernel routine* receives a *pointer* to the arguments and to the *normal routine* of the APC and operates at *APC_LEVEL*, where it can choose to queue a new, normal APC.
- **Normal Kernel APC** This type of APC is always inserted at the tail end of the APC queue, allowing for a special kernel APC to queue a new normal kernel APC that will execute soon thereafter, as described in the earlier example. These kinds of APCs can not only be disabled through the mechanisms presented earlier but also through a third API called *KeEnterCriticalRegion* (paired with *KeLeaveCriticalRegion*), which updates the *KernelApcDisable* counter in KTHREAD but not *SpecialApcDisable*.
- These APCs first execute their *kernel routine* at *APC_LEVEL*, sending it pointers to the arguments and the *normal routine*. If the normal routine hasn't been cleared as a result, they then drop the IRQL to *PASSIVE_LEVEL* and execute the normal routine as well, with the input arguments passed in by value this time. Once the normal routine returns, the IRQL is raised back to *APC_LEVEL* again.
- **Normal User APC** This typical combination causes the APC to be inserted at the tail of the APC queue and for the *kernel routine* to first execute at *APC_LEVEL* in the same way as the preceding bullet. If a *normal routine* is still present, then the APC is prepared for user-mode

delivery (obviously, at *PASSIVE_LEVEL*) through the creation of a trap frame and exception frame that will eventually cause the user-mode APC dispatcher in *Ntdll.dll* to take control of the thread once back in user mode, and which will call the supplied user pointer. Once the user-mode APC returns, the dispatcher uses the *NtContinue* or *NtContinueEx* system call to return to the original trap frame.

- Note that if the kernel routine ended up clearing out the normal routine, then the thread, if alerted, loses that state, and, conversely, if not alerted, becomes alerted, and the user APC pending flag is set, potentially causing other user-mode APCs to be delivered soon. This is performed by the *KeTestAlertThread* API to essentially still behave as if the normal APC would've executed in user mode, even though the kernel routine cancelled the dispatch.
- **Special User APC** This combination of APC is a recent addition to newer builds of Windows 10 and generalizes a special dispensation that was done for the thread termination APC such that other developers can make use of it as well. As we'll soon see, the act of terminating a remote (noncurrent) thread requires the use of an APC, but it must also only occur once all kernel-mode code has finished executing. Delivering the termination code as a User APC would fit the bill quite well, but it would mean that a user-mode developer could avoid termination by performing a nonalertable wait or filling their queue with other User APCs instead.

To fix this scenario, the kernel long had a hard-coded check to validate if the *kernel routine* of a User APC was *KiSchedulerApcTerminate*. In this situation, the User APC was recognized as being "special" and put at the head of the queue. Further, the status of the thread was ignored, and the "user APC pending" state was always set, which forced execution of the APC at the next user-mode ring transition or context switch to this thread.

This functionality, however, being solely reserved for the termination code path, meant that developers who want to similarly guarantee the execution of their User APC, regardless of alertability state, had to resort to using more complex mechanisms such as manually changing the context of the thread using *SetThreadContext*, which is error-prone at best. In response, the *QueueUserAPC2* API was created, which allows passing in the *QUEUE_USER_APC_FLAGS_SPECIAL_USER_APC* flag, officially exposing similar functionality to developers as well. Such APCs will always be added before any other user-mode APCs (except the termination APC, which is now extra special) and will ignore the alertable flag in the case of a waiting thread. Additionally, the APC will first be inserted exceptionally as a Special Kernel APC such that its kernel routine will execute almost instantaneously to then reregister the APC as a special user APC.

Table 8-9 summarizes the APC insertion and delivery behavior for each type of APC.

The executive uses kernel-mode APCs to perform operating system work that must be completed within the address space (in the context) of a particular thread. It can use special kernel-mode APCs to direct a thread to stop executing an interruptible system service, for example, or to record the results of an asynchronous I/O operation in a thread's address space. Environment subsystems use special kernel-mode APCs to make a thread suspend or terminate itself or to get or set its user-mode execution context. The Windows Subsystem for Linux (WSL) uses kernel-mode APCs to emulate the delivery of UNIX signals to Subsystem for UNIX Application processes.

TABLE 8-9 APC insertion and delivery

APC Type	Insertion Behavior	Delivery Behavior
Special (kernel)	Inserted right after the last special APC (at the head of all other normal APCs)	Kernel routine delivered at APC level as soon as IRQL drops, and the thread is not in a guarded region. It is given pointers to arguments specified when inserting the APC.
Normal (kernel)	Inserted at the tail of the kernel-mode APC list	Kernel routine delivered at <i>APC_LEVEL</i> as soon as IRQL drops, and the thread is not in a critical (or guarded) region. It is given pointers to arguments specified when inserting the APC. Executes the normal routine, if any, at <i>PASSIVE_LEVEL</i> after the associated kernel routine was executed. It is given arguments returned by the associated kernel routine (which can be the original arguments used during insertion or new ones).
Normal (user)	Inserted at the tail of the user-mode APC list	Kernel routine delivered at <i>APC_LEVEL</i> as soon as IRQL drops and the thread has the “user APC pending” flag set (indicating that an APC was queued while the thread was in an alertable wait state). It is given pointers to arguments specified when inserting the APC. Executes the normal routine, if any, in user mode at <i>PASSIVE_LEVEL</i> after the associated kernel routine is executed. It is given arguments returned by the associated kernel routine (which can be the original arguments used during insertion or new ones). If the normal routine was cleared by the kernel routine, it performs a <i>test-alert</i> against the thread.
User Thread Terminate APC (<i>KiSchedulerApcTerminate</i>)	Inserted at the head of the user-mode APC list	Immediately sets the “user APC pending” flag and follows similar rules as described earlier but delivered at <i>PASSIVE_LEVEL</i> on return to user mode, no matter what. It is given arguments returned by the thread-termination special APC.
Special (user)	Inserted at the head of the user-mode APC list but after the thread terminates APC, if any.	Same as above, but arguments are controlled by the caller of <i>QueueUserAPC2</i> (<i>NtQueueApcThreadEx2</i>). Kernel routine is internal <i>KeSpecialUserApcKernelRoutine</i> function that re-inserts the APC, converting it from the initial special kernel APC to a special user APC.

Another important use of kernel-mode APCs is related to thread suspension and termination. Because these operations can be initiated from arbitrary threads and directed to other arbitrary threads, the kernel uses an APC to query the thread context as well as to terminate the thread. Device drivers often block APCs or enter a critical or guarded region to prevent these operations from occurring while they are holding a lock; otherwise, the lock might never be released, and the system would hang.

Device drivers also use kernel-mode APCs. For example, if an I/O operation is initiated and a thread goes into a wait state, another thread in another process can be scheduled to run. When the device finishes transferring data, the I/O system must somehow get back into the context of the thread that initiated the I/O so that it can copy the results of the I/O operation to the buffer in the address space of the process containing that thread. The I/O system uses a special kernel-mode APC to perform this action unless the application used the *SetFileIoOverlappedRange* API or I/O completion ports. In that case, the buffer will either be global in memory or copied only after the thread pulls a completion item from the port. (The use of APCs in the I/O system is discussed in more detail in Chapter 6 of Part 1.)

Several Windows APIs—such as *ReadFileEx*, *WriteFileEx*, and *QueueUserAPC*—use user-mode APCs. For example, the *ReadFileEx* and *WriteFileEx* functions allow the caller to specify a completion routine to be called when the I/O operation finishes. The I/O completion is implemented by queuing an APC to the thread that issued the I/O. However, the callback to the completion routine doesn't necessarily take place when the APC is queued because user-mode APCs are delivered to a thread only when it's in an *alertable wait state*. A thread can enter a wait state either by waiting for an object handle and specifying that its wait is alertable (with the Windows *WaitForMultipleObjectsEx* function) or by testing directly whether it has a pending APC (using *SleepEx*). In both cases, if a user-mode APC is pending, the kernel interrupts (alerts) the thread, transfers control to the APC routine, and resumes the thread's execution when the APC routine completes. Unlike kernel-mode APCs, which can execute at *APC_LEVEL*, user-mode APCs execute at *PASSIVE_LEVEL*.

APC delivery can reorder the wait queues—the lists of which threads are waiting for what, and in what order they are waiting. (Wait resolution is described in the section “Low-IRQL synchronization,” later in this chapter.) If the thread is in a wait state when an APC is delivered, after the APC routine completes, the wait is reissued or re-executed. If the wait still isn't resolved, the thread returns to the wait state, but now it will be at the end of the list of objects it's waiting for. For example, because APCs are used to suspend a thread from execution, if the thread is waiting for any objects, its wait is removed until the thread is resumed, after which that thread will be at the end of the list of threads waiting to access the objects it was waiting for. A thread performing an alertable kernel-mode wait will also be woken up during thread termination, allowing such a thread to check whether it woke up as a result of termination or for a different reason.

Timer processing

The system's clock interval timer is probably the most important device on a Windows machine, as evidenced by its high IRQL value (*CLOCK_LEVEL*) and due to the critical nature of the work it is responsible for. Without this interrupt, Windows would lose track of time, causing erroneous results in calculations of uptime and clock time—and worse, causing timers to no longer expire, and threads never to consume their quantum. Windows would also not be a preemptive operating system, and unless the current running thread yielded the CPU, critical background tasks and scheduling could never occur on a given processor.

Timer types and intervals

Traditionally, Windows programmed the system clock to fire at some appropriate interval for the machine, and subsequently allowed drivers, applications, and administrators to modify the clock interval for their needs. This system clock thus fired in a fixed, periodic fashion, maintained by either by the Programmable Interrupt Timer (PIT) chip that has been present on all computers since the PC/AT or the Real Time Clock (RTC). The PIT works on a crystal that is tuned at one-third the NTSC color carrier frequency (because it was originally used for TV-Out on the first CGA video cards), and the HAL uses various achievable multiples to reach millisecond-unit intervals, starting at 1 ms all the way up to 15 ms. The RTC, on the other hand, runs at 32.768 kHz, which, by being a power of two, is easily configured to run at various intervals that are also powers of two. On RTC-based systems, the APIC Multiprocessor HAL configured the RTC to fire every 15.6 milliseconds, which corresponds to about 64 times a second.

The PIT and RTC have numerous issues: They are slow, external devices on legacy buses, have poor granularity, force all processors to synchronize access to their hardware registers, are a pain to emulate, and are increasingly no longer found on embedded hardware devices, such as IoT and mobile. In response, hardware vendors created new types of timers, such as the ACPI Timer, also sometimes called the Power Management (PM) Timer, and the APIC Timer (which lives directly on the processor). The ACPI Timer achieved good flexibility and portability across hardware architectures, but its latency and implementation bugs caused issues. The APIC Timer, on the other hand, is highly efficient but is often already used by other platform needs, such as for profiling (although more recent processors now have dedicated profiling timers).

In response, Microsoft and the industry created a specification called the High Performance Event Timer, or HPET, which is a much-improved version of the RTC. On systems with an HPET, it is used instead of the RTC or PIC. Additionally, ARM64 systems have their own timer architecture, called the Generic Interrupt Timer (GIT). All in all, the HAL maintains a complex hierarchy of finding the best possible timer on a given system, using the following order:

1. Try to find a synthetic hypervisor timer to avoid any kind of emulation if running inside of a virtual machine.
2. On physical hardware, try to find a GIT. This is expected to work only on ARM64 systems.
3. If possible, try to find a per-processor timer, such as the Local APIC timer, if not already used.
4. Otherwise, find an HPET—going from an MSI-capable HPET to a legacy periodic HPET to any kind of HPET.
5. If no HPET was found, use the RTC.
6. If no RTC is found, try to find some other kind of timer, such as the PIT or an SFI Timer, first trying to find ones that support MSI interrupts, if possible.
7. If no timer has yet been found, the system doesn't actually have a Windows compatible timer, which should never happen.

The HPET and the LAPIC Timer have one more advantage—other than only supporting the typical *periodic* mode we described earlier, they can also be configured in a *one shot* mode. This capability will allow recent versions of Windows to leverage a *dynamic tick* model, which we explain later.

Timer granularity

Some types of Windows applications require very fast response times, such as multimedia applications. In fact, some multimedia tasks require rates as low as 1 ms. For this reason, Windows from early on implemented APIs and mechanisms that enable lowering the interval of the system's clock interrupt, which results in more frequent clock interrupts. These APIs do not adjust a particular timer's specific rate (that functionality was added later, through *enhanced* timers, which we cover in an upcoming section); instead, they end up increasing the resolution of all timers in the system, potentially causing other timers to expire more frequently, too.

That being said, Windows tries its best to restore the clock timer back to its original value whenever it can. Each time a process requests a clock interval change, Windows increases an internal reference count and associates it with the process. Similarly, drivers (which can also change the clock rate) get added to the global reference count. When all drivers have restored the clock and all processes that modified the clock either have exited or restored it, Windows restores the clock to its default value (or barring that, to the next highest value that's been required by a process or driver).

EXPERIMENT: Identifying high-frequency timers

Due to the problems that high-frequency timers can cause, Windows uses Event Tracing for Windows (ETW) to trace all processes and drivers that request a change in the system's clock interval, displaying the time of the occurrence and the requested interval. The current interval is also shown. This data is of great use to both developers and system administrators in identifying the causes of poor battery performance on otherwise healthy systems, as well as to decrease overall power consumption on large systems. To obtain it, simply run **powercfg /energy**, and you should obtain an HTML file called *energy-report.html*, similar to the one shown here:

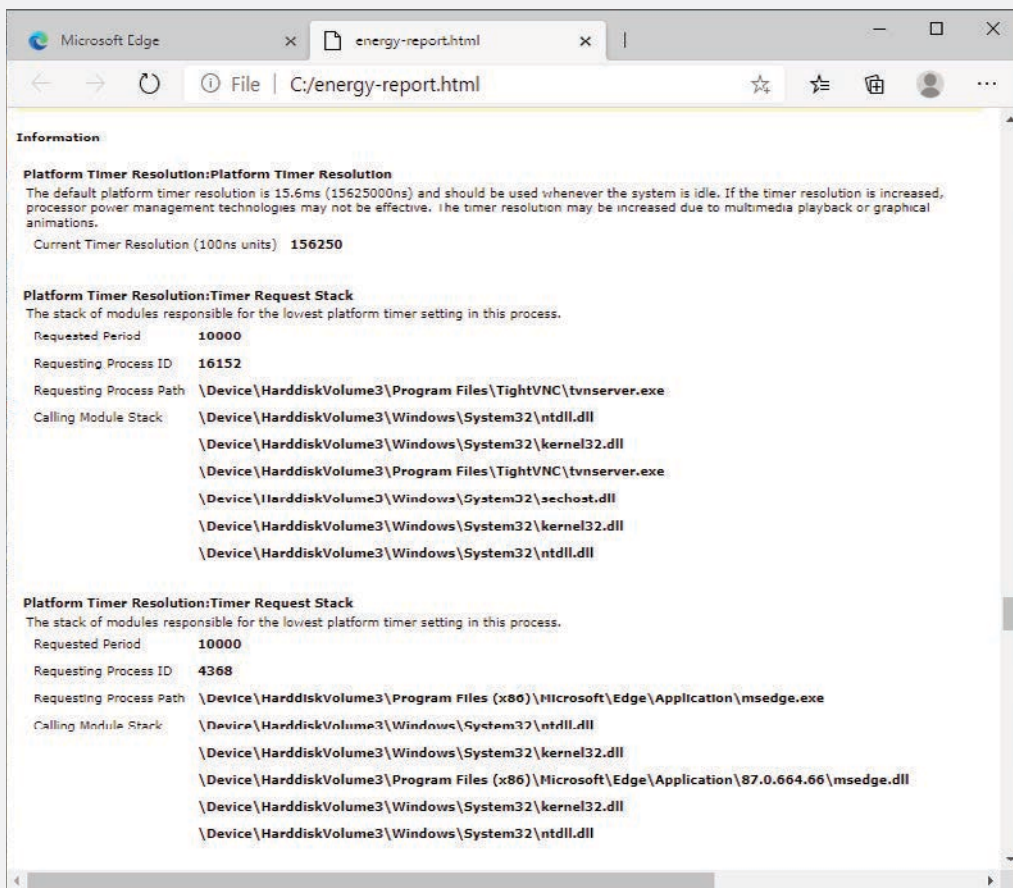

Scroll down to the Platform Timer Resolution section, and you see all the applications that have modified the timer resolution and are still active, along with the call stacks that caused this call. Timer resolutions are shown in hundreds of nanoseconds, so a period of 20,000 corresponds to 2 ms. In the sample shown, two applications—namely, Microsoft Edge and the TightVNC remote desktop server—each requested a higher resolution.

You can also use the debugger to obtain this information. For each process, the *EPROCESS* structure contains the fields shown next that help identify changes in timer resolution:

```
+0x4a8 TimerResolutionLink : _LIST_ENTRY [ 0xfffffa80'05218fd8 - 0xfffffa80'059cd508 ]
+0x4b8 RequestedTimerResolution : 0
+0x4bc ActiveThreadsHighWatermark : 0x1d
+0x4c0 SmallestTimerResolution : 0x2710
+0x4c8 TimerResolutionStackRecord : 0xfffff8a0'0476ecd0 _PO_DIAG_STACK_RECORD
```

Note that the debugger shows you an additional piece of information: the smallest timer resolution that was ever requested by a given process. In this example, the process shown corresponds to PowerPoint 2010, which typically requests a lower timer resolution during slideshows but not during slide editing mode. The *EPROCESS* fields of PowerPoint, shown in the preceding code, prove this, and the stack could be parsed by dumping the *PO_DIAG_STACK_RECORD* structure.

Finally, the *TimerResolutionLink* field connects all processes that have made changes to timer resolution, through the *ExpTimerResolutionListHead* doubly linked list. Parsing this list with the debugger data model can reveal all processes on the system that have, or had, made changes to the timer resolution, when the *powercfg* command is unavailable or information on past processes is required. For example, this output shows that Edge, at various points, requested a 1 ms resolution, as did the Remote Desktop Client, and Cortana. WinDbg Preview, however, now only previously requested it but is still requesting it at the moment this command was written.

```
lkd> dx -g Debugger.Utility.Collections.FromListEntry(*(nt!_LIST_ENTRY*)&nt!ExpTimerResolutionListHead, "nt!_EPROCESS", "TimerResolutionLink").Select(p => new { Name = ((char*) p.ImageFileName).ToString("sb"), Smallest = p.SmallestTimerResolution, Requested = p.RequestedTimerResolution}),d
```

```
=====
=           = Name           = Smallest = Requested =
=====
= [0]      - msedge.exe       - 10000   - 0         =
= [1]      - msedge.exe       - 10000   - 0         =
= [2]      - msedge.exe       - 10000   - 0         =
= [3]      - msedge.exe       - 10000   - 0         =
= [4]      - mstsc.exe        - 10000   - 0         =
= [5]      - msedge.exe       - 10000   - 0         =
= [6]      - msedge.exe       - 10000   - 0         =
= [7]      - msedge.exe       - 10000   - 0         =
= [8]      - DbgX.Shell.exe   - 10000   - 10000    =
= [9]      - msedge.exe       - 10000   - 0         =
= [10]     - msedge.exe       - 10000   - 0         =
= [11]     - msedge.exe       - 10000   - 0         =
= [12]     - msedge.exe       - 10000   - 0         =
= [13]     - msedge.exe       - 10000   - 0         =
= [14]     - msedge.exe       - 10000   - 0         =
```



```

= [15] - msedge.exe - 10000 - 0 =
= [16] - msedge.exe - 10000 - 0 =
= [17] - msedge.exe - 10000 - 0 =
= [18] - msedge.exe - 10000 - 0 =
= [19] - SearchApp.exe - 40000 - 0 =
=====

```

Timer expiration

As we said, one of the main tasks of the ISR associated with the interrupt that the clock source generates is to keep track of system time, which is mainly done by the *KeUpdateSystemTime* routine. Its second job is to keep track of logical run time, such as process/thread execution times and the system *tick time*, which is the underlying number used by APIs such as *GetTickCount* that developers use to time operations in their applications. This part of the work is performed by *KeUpdateRunTime*. Before doing any of that work, however, *KeUpdateRunTime* checks whether any timers have expired.

Windows timers can be either *absolute* timers, which implies a distinct expiration time in the future, or *relative* timers, which contain a negative expiration value used as a positive offset from the current time during timer insertion. Internally, all timers are converted to an absolute expiration time, although the system keeps track of whether this is the “true” absolute time or a converted relative time. This difference is important in certain scenarios, such as Daylight Savings Time (or even manual clock changes). An absolute timer would still fire at 8:00 p.m. if the user moved the clock from 1:00 p.m. to 7:00 p.m., but a relative timer—say, one set to expire “in two hours”—would not feel the effect of the clock change because two hours haven’t really elapsed. During system time-change events such as these, the kernel reprograms the absolute time associated with relative timers to match the new settings.

Back when the clock only fired in a periodic mode, since its expiration was at known interval multiples, each multiple of the system time that a timer could be associated with is an index called a hand, which is stored in the timer object’s dispatcher header. Windows used that fact to organize all driver and application timers into linked lists based on an array where each entry corresponds to a possible multiple of the system time. Because modern versions of Windows 10 no longer necessarily run on a periodic tick (due to the *dynamic tick* functionality), a hand has instead been redefined as the upper 46 bits of the due time (which is in 100 ns units). This gives each hand an approximate “time” of 28 ms. Additionally, because on a given tick (especially when not firing on a fixed periodic interval), multiple hands could have expiring timers, Windows can no longer just check the current hand. Instead, a bit-map is used to track each hand in each processor’s timer table. These pending hands are found using the bitmap and checked during every clock interrupt.

Regardless of method, these 256 linked lists live in what is called the *timer table*—which is in the PRCB—enabling each processor to perform its own independent timer expiration without needing to acquire a global lock, as shown in Figure 8-19. Recent builds of Windows 10 can have up to two timer tables, for a total of 512 linked lists.

Later, you will see what determines which logical processor’s timer table a timer is inserted on. Because each processor has its own timer table, each processor also does its own timer expiration

work. As each processor gets initialized, the table is filled with absolute timers with an infinite expiration time to avoid any incoherent state. Therefore, to determine whether a clock has expired, it is only necessary to check if there are any timers on the linked list associated with the current hand.

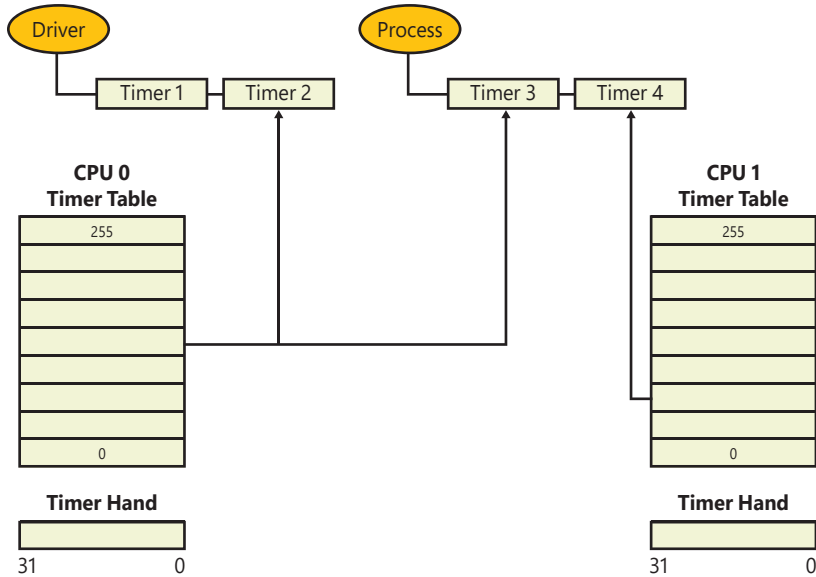

FIGURE 8-19 Example of per-processor timer lists.

Although updating counters and checking a linked list are fast operations, going through every timer and expiring it is a potentially costly operation—keep in mind that all this work is currently being performed at *CLOCK_LEVEL*, an exceptionally elevated IRQ. Similar to how a driver ISR queues a DPC to defer work, the clock ISR requests a DPC software interrupt, setting a flag in the PRCB so that the DPC draining mechanism knows timers need expiration. Likewise, when updating process/thread runtime, if the clock ISR determines that a thread has expired its quantum, it also queues a DPC software interrupt and sets a different PRCB flag. These flags are per-PRCB because each processor normally does its own processing of run-time updates because each processor is running a different thread and has different tasks associated with it. Table 8-10 displays the various fields used in timer expiration and processing.

DPCs are provided primarily for device drivers, but the kernel uses them, too. The kernel most frequently uses a DPC to handle quantum expiration. At every tick of the system clock, an interrupt occurs at clock IRQ. The *clock interrupt handler* (running at clock IRQ) updates the system time and then decrements a counter that tracks how long the current thread has run. When the counter reaches 0, the thread's time quantum has expired, and the kernel might need to reschedule the processor, a lower-priority task that should be done at DPC/dispatch IRQ. The clock interrupt handler queues a DPC to initiate thread dispatching and then finishes its work and lowers the processor's IRQ. Because the DPC interrupt has a lower priority than do device interrupts, any pending device interrupts that surface before the clock interrupt completes are handled before the DPC interrupt occurs.

Once the IRQ eventually drops back to *DISPATCH_LEVEL*, as part of DPC processing, these two flags will be picked up.

TABLE 8-10 Timer processing KPRCB fields

KPRCB Field	Type	Description
<i>LastTimerHand</i>	Index (up to 256)	The last timer hand that was processed by this processor. In recent builds, part of TimerTable because there are now two tables.
<i>ClockOwner</i>	Boolean	Indicates whether the current processor is the clock owner.
<i>TimerTable</i>	KTIMER_TABLE	List heads for the timer table lists (256, or 512 on more recent builds).
<i>DpcNormalTimerExpiration</i>	Bit	Indicates that a <i>DISPATCH_LEVEL</i> interrupt has been raised to request timer expiration.

Chapter 4 of Part 1 covers the actions related to thread scheduling and quantum expiration. Here, we look at the timer expiration work. Because the timers are linked together by hand, the expiration code (executed by the DPC associated with the PRCB in the *TimerExpirationDpc* field, usually *KiTimerExpirationDpc*) parses this list from head to tail. (At insertion time, the timers nearest to the clock interval multiple will be first, followed by timers closer and closer to the next interval but still within this hand.) There are two primary tasks to expiring a timer:

- The timer is treated as a dispatcher synchronization object (threads are waiting on the timer as part of a timeout or directly as part of a wait). The wait-testing and wait-satisfaction algorithms will be run on the timer. This work is described in a later section on synchronization in this chapter. This is how user-mode applications, and some drivers, make use of timers.
- The timer is treated as a control object associated with a DPC callback routine that executes when the timer expires. This method is reserved only for drivers and enables very low latency response to timer expiration. (The wait/dispatcher method requires all the extra logic of wait signaling.) Additionally, because timer expiration itself executes at *DISPATCH_LEVEL*, where DPCs also run, it is perfectly suited as a timer callback.

As each processor wakes up to handle the clock interval timer to perform system-time and run-time processing, it therefore also processes timer expirations after a slight latency/delay in which the IRQL drops from *CLOCK_LEVEL* to *DISPATCH_LEVEL*. Figure 8-20 shows this behavior on two processors—the solid arrows indicate the clock interrupt firing, whereas the dotted arrows indicate any timer expiration processing that might occur if the processor had associated timers.

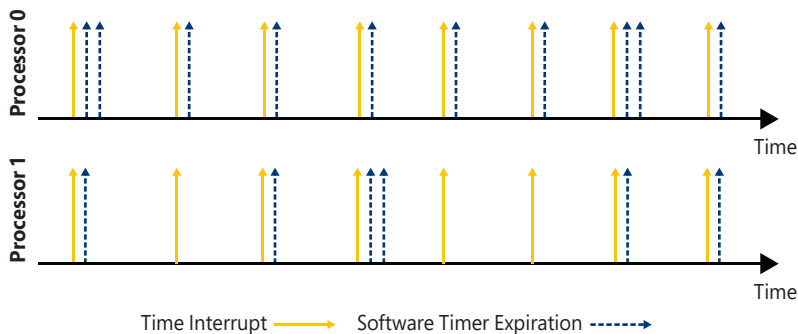

FIGURE 8-20 Timer expiration.

Processor selection

A critical determination that must be made when a timer is inserted is to pick the appropriate table to use—in other words, the most optimal processor choice. First, the kernel checks whether *timer serialization* is disabled. If it is, it then checks whether the timer has a DPC associated with its expiration, and if the DPC has been affinitized to a target processor, in which case it selects that processor's timer table. If the timer has no DPC associated with it, or if the DPC has not been bound to a processor, the kernel scans all processors in the current processor's group that have not been parked. (For more information on core parking, see Chapter 4 of Part 1.) If the current processor is parked, it picks the next closest neighboring unparked processor in the same NUMA node; otherwise, the current processor is used.

This behavior is intended to improve performance and scalability on server systems that make use of Hyper-V, although it can improve performance on any heavily loaded system. As system timers pile up—because most drivers do not affinitize their DPCs—CPU 0 becomes more and more congested with the execution of timer expiration code, which increases latency and can even cause heavy delays or missed DPCs. Additionally, timer expiration can start competing with DPCs typically associated with driver interrupt processing, such as network packet code, causing systemwide slowdowns. This process is exacerbated in a Hyper-V scenario, where CPU 0 must process the timers and DPCs associated with potentially numerous virtual machines, each with their own timers and associated devices.

By spreading the timers across processors, as shown in Figure 8-21, each processor's timer-expiration load is fully distributed among unparked logical processors. The timer object stores its associated processor number in the dispatcher header on 32-bit systems and in the object itself on 64-bit systems.

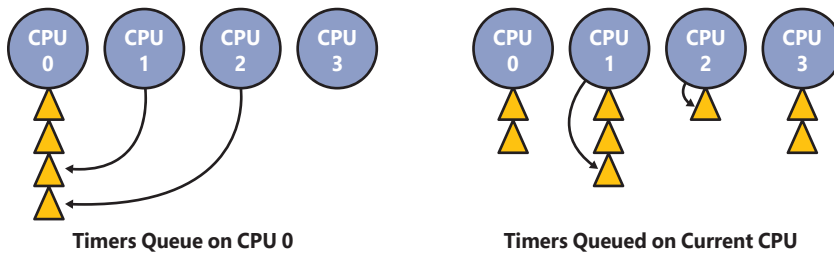

FIGURE 8-21 Timer queuing behaviors.

This behavior, although highly beneficial on servers, does not typically affect client systems that much. Additionally, it makes each timer expiration event (such as a clock tick) more complex because a processor may have gone idle but still have had timers associated with it, meaning that the processor(s) still receiving clock ticks need to potentially scan everyone else's processor tables, too. Further, as various processors may be cancelling and inserting timers simultaneously, it means there's inherent asynchronous behaviors in timer expiration, which may not always be desired. This complexity makes it nearly impossible to implement Modern Standby's resiliency phase because no one single processor can ultimately remain to manage the clock. Therefore, on client systems, *timer serialization* is enabled if Modern Standby is available, which causes the kernel to choose CPU 0 no matter what. This allows CPU 0 to behave as the default *clock owner*—the processor that will always be active to pick up clock interrupts (more on this later).



Note This behavior is controlled by the kernel variable *KiSerializeTimerExpiration*, which is initialized based on a registry setting whose value is different between a server and client installation. By modifying or creating the value *SerializeTimerExpiration* under HKLM\SYSTEM\CurrentControlSet\Control\Session Manager\Kernel and setting it to any value other than 0 or 1, serialization can be disabled, enabling timers to be distributed among processors. Deleting the value, or keeping it as 0, allows the kernel to make the decision based on Modern Standby availability, and setting it to 1 permanently enables serialization even on non-Modern Standby systems.

EXPERIMENT: Listing system timers

You can use the kernel debugger to dump all the current registered timers on the system, as well as information on the DPC associated with each timer (if any). See the following output for a sample:

```
0: kd> !timer
Dump system timers

Interrupt time: 250fdc0f 00000000 [12/21/2020 03:30:27.739]

PROCESSOR 0 (nt!_KTIMER_TABLE fffff8011bea6d80 - Type 0 - High precision)
List Timer                Interrupt Low/High Fire Time                DPC/thread

PROCESSOR 0 (nt!_KTIMER_TABLE fffff8011bea6d80 - Type 1 - Standard)
List Timer                Interrupt Low/High Fire Time                DPC/thread
 1 fffffdb08d6b2f0b0      0807e1fb 80000000 [          NEVER          ] thread fffffdb08d748f480
 4 fffffdb08d7837a20      6810de65 00000008 [12/21/2020 04:29:36.127]
 6 fffffdb08d2cfc6b0      4c18f0d1 00000000 [12/21/2020 03:31:33.230] netbt!TimerExpiry
                               (DPC @ fffffdb08d2cfc670)
 fffff8011fd3d8a8 A fc19cdd1 00589a19 [ 1/ 1/2100 00:00:00.054] nt!ExpCenturyDpcRoutine
                               (DPC @ fffff8011fd3d868)
 7 fffffdb08d8640440      3b22a3a3 00000000 [12/21/2020 03:31:04.772] thread fffffdb08d85f2080
 fffffdb08d0fef300      7723f6b5 00000001 [12/21/2020 03:39:54.941]
                               FLTMRG!FltpIrpCtrlStackProfilerTimer (DPC @ fffffdb08d0fef340)
11 fffff8011fcffe70      6c2d7643 00000000 [12/21/2020 03:32:27.052] nt!KdpTimeSlipDpcRoutine
                               (DPC @ fffff8011fcffe30)
 fffffdb08d75f0180      c42fec8e 00000000 [12/21/2020 03:34:54.707] thread fffffdb08d75f0080
14 fffff80123475420      283baec0 00000000 [12/21/2020 03:30:33.060] tcpip!IppTimeout
                               (DPC @ fffff80123475460)
. . .
58 fffffdb08d863e280 P 3fec06d0 00000000 [12/21/2020 03:31:12.803] thread fffffdb08d8730080
 fffff8011fd3d948 A 90eb4dd1 00000887 [ 1/ 1/2021 00:00:00.054] nt!ExpNextYearDpcRoutine
                               (DPC @ fffff8011fd3d908)
. . .
104 fffffdb08d27e6d78 P 25a25441 00000000 [12/21/2020 03:30:28.699]
                               tcpip!TcpPeriodicTimeoutHandler (DPC @ fffffdb08d27e6d38)
 fffffdb08d27e6f10 P 25a25441 00000000 [12/21/2020 03:30:28.699]
                               tcpip!TcpPeriodicTimeoutHandler (DPC @ fffffdb08d27e6ed0)
106 fffffdb08d29db048 P 251210d3 00000000 [12/21/2020 03:30:27.754]
                               CLASSPNP!ClassCleanupPacketTimerDpc (DPC @ fffffdb08d29db088)
```

```

fffff80122e9d110 258f6e00 00000000 [12/21/2020 03:30:28.575]
                    Ntfs!NtfsVolumeCheckpointDpc (DPC @ fffff80122e9d0d0)
108 fffff8011c6e6560 19b1caef 00000002 [12/21/2020 03:44:27.661]
                    tm!TmpCheckForProgressDpcRoutine (DPC @ fffff8011c6e65a0)
111 fffffdb08d27d5540 P 25920ab5 00000000 [12/21/2020 03:30:28.592]
                    storport!RaidUnitPendingDpcRoutine (DPC @ fffffdb08d27d5580)
fffffdb08d27da540 P 25920ab5 00000000 [12/21/2020 03:30:28.592]
                    storport!RaidUnitPendingDpcRoutine (DPC @ fffffdb08d27da580)
. . .

Total Timers: 221, Maximum List: 8
Current Hand: 139

```

In this example, which has been shortened for space reasons, there are multiple driver-associated timers, due to expire shortly, associated with the Netbt.sys and Tcip.sys drivers (both related to networking), as well as Ntfs, the storage controller driver drivers. There are also background housekeeping timers due to expire, such as those related to power management, ETW, registry flushing, and Users Account Control (UAC) virtualization. Additionally, there are a dozen or so timers that don't have any DPC associated with them, which likely indicates user-mode or kernel-mode timers that are used for wait dispatching. You can use **!thread** on the thread pointers to verify this.

Finally, three interesting timers that are always present on a Windows system are the timer that checks for Daylight Savings Time time-zone changes, the timer that checks for the arrival of the upcoming year, and the timer that checks for entry into the next century. One can easily locate them based on their typically distant expiration time, unless this experiment is performed on the eve of one of these events.

Intelligent timer tick distribution

Figure 8-20, which shows processors handling the clock ISR and expiring timers, reveals that processor 1 wakes up several times (the solid arrows) even when there are no associated expiring timers (the dotted arrows). Although that behavior is required as long as processor 1 is running (to update the thread/process run times and scheduling state), what if processor 1 is idle (and has no expiring timers)? Does it still need to handle the clock interrupt? Because the only other work required that was referenced earlier is to update the overall system time/clock ticks, it's sufficient to designate merely one processor as the time-keeping processor (in this case, processor 0) and allow other processors to remain in their sleep state; if they wake, any time-related adjustments can be performed by resynchronizing with processor 0.

Windows does, in fact, make this realization (internally called *intelligent timer tick distribution*), and Figure 8-22 shows the processor states under the scenario where processor 1 is sleeping (unlike earlier, when we assumed it was running code). As you can see, processor 1 wakes up only five times to handle its expiring timers, creating a much larger gap (sleeping period). The kernel uses a variable *KiPendingTimerBitmaps*, which contains an array of affinity mask structures that indicate which logical processors need to receive a clock interval for the given timer hand (clock-tick interval). It can then

appropriately program the interrupt controller, as well as determine to which processors it will send an IPI to initiate timer processing.

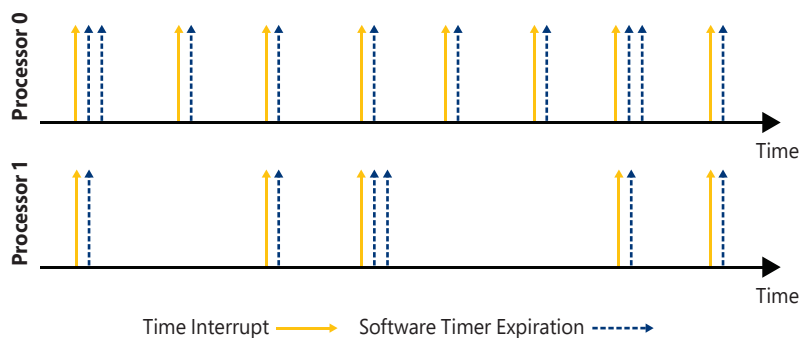

FIGURE 8-22 Intelligent timer tick distribution applied to processor 1.

Leaving as large a gap as possible is important due to the way power management works in processors: as the processor detects that the workload is going lower and lower, it decreases its power consumption (P states), until it finally reaches an idle state. The processor then can selectively turn off parts of itself and enter deeper and deeper idle/sleep states, such as turning off caches. However, if the processor has to wake again, it will consume energy and take time to power up; for this reason, processor designers will risk entering these lower idle/sleep states (C-states) only if the time spent in a given state outweighs the time and energy it takes to enter and exit the state. Obviously, it makes no sense to spend 10 ms to enter a sleep state that will last only 1 ms. By preventing clock interrupts from waking sleeping processors unless needed (due to timers), they can enter deeper C-states and stay there longer.

Timer coalescing

Although minimizing clock interrupts to sleeping processors during periods of no timer expiration gives a big boost to longer C-state intervals, with a timer granularity of 15 ms, many timers likely will be queued at any given hand and expire often, even if just on processor 0. Reducing the amount of software timer-expiration work would both help to decrease latency (by requiring less work at `DISPATCH_LEVEL`) as well as allow other processors to stay in their sleep states even longer. (Because we've established that the processors wake up only to handle expiring timers, fewer timer expirations result in longer sleep times.) In truth, it is not just the number of expiring timers that really affects sleep state (it does affect latency), but the periodicity of these timer expirations—six timers all expiring at the same hand is a better option than six timers expiring at six different hands. Therefore, to fully optimize idle-time duration, the kernel needs to employ a *coalescing* mechanism to combine separate timer hands into an individual hand with multiple expirations.

Timer coalescing works on the assumption that most drivers and user-mode applications do not particularly care about the exact firing period of their timers (except in the case of multimedia applications, for example). This “don't care” region grows as the original timer period grows—an application waking up every 30 seconds probably doesn't mind waking up every 31 or 29 seconds instead, while a driver polling every second could probably poll every second plus or minus 50 ms without too

many problems. The important guarantee most periodic timers depend on is that their firing period remains constant within a certain range—for example, when a timer has been changed to fire every second plus 50 ms, it continues to fire within that range forever, not sometimes at every two seconds and other times at half a second. Even so, not all timers are ready to be coalesced into coarser granularities, so Windows enables this mechanism only for timers that have marked themselves as coalescable, either through the *KeSetCoalescableTimer* kernel API or through its user-mode counterpart, *SetWaitableTimerEx*.

With these APIs, driver and application developers are free to provide the kernel with the maximum *tolerance* (or tolerably delay) that their timer will endure, which is defined as the maximum amount of time past the requested period at which the timer will still function correctly. (In the previous example, the 1-second timer had a tolerance of 50 ms.) The recommended minimum tolerance is 32 ms, which corresponds to about twice the 15.6 ms clock tick—any smaller value wouldn't really result in any coalescing because the expiring timer could not be moved even from one clock tick to the next. Regardless of the tolerance that is specified, Windows aligns the timer to one of four *preferred coalescing intervals*: 1 second, 250 ms, 100 ms, or 50 ms.

When a tolerable delay is set for a periodic timer, Windows uses a process called *shifting*, which causes the timer to drift between periods until it gets aligned to the most optimal multiple of the period interval within the preferred coalescing interval associated with the specified tolerance (which is then encoded in the dispatcher header). For absolute timers, the list of preferred coalescing intervals is scanned, and a preferred expiration time is generated based on the closest acceptable coalescing interval to the maximum tolerance the caller specified. This behavior means that absolute timers are always pushed out as far as possible past their real expiration point, which spreads out timers as far as possible and creates longer sleep times on the processors.

Now with timer coalescing, refer to Figure 8-20 and assume all the timers specified tolerances and are thus coalescable. In one scenario, Windows could decide to coalesce the timers as shown in Figure 8-23. Notice that now, processor 1 receives a total of only three clock interrupts, significantly increasing the periods of idle sleep, thus achieving a lower C-state. Furthermore, there is less work to do for some of the clock interrupts on processor 0, possibly removing the latency of requiring a drop to *DISPATCH_LEVEL* at each clock interrupt.

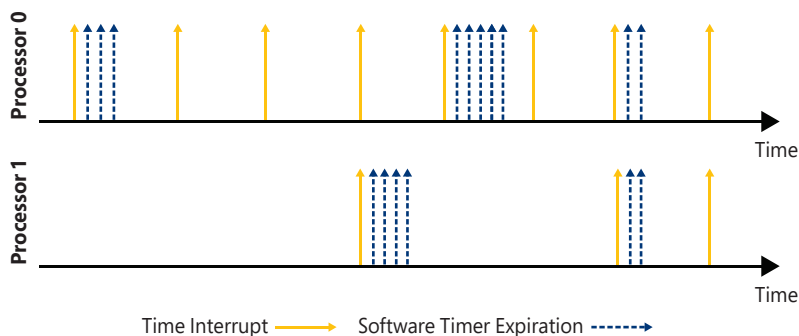

FIGURE 8-23 Timer coalescing.

Enhanced timers

Enhanced timers were introduced to satisfy a long list of requirements that previous timer system improvements had still not yet addressed. For one, although timer coalescing reduced power usage, it also made timers have inconsistent expiration times, even when there was no need to reduce power (in other words, coalescing was an all-or-nothing proposition). Second, the only mechanism in Windows for high-resolution timers was for applications and drivers to lower the clock tick globally, which, as we've seen, had significant negative impact on systems. And, ironically, even though the resolution of these timers was now higher, they were not necessarily more precise because regular time expiration can happen *before* the clock tick, regardless of how much more granular it's been made.

Finally, recall that the introduction of Connected/Modern Standby, described in Chapter 6 of Part 1, added features such as timer virtualization and the Desktop Activity Moderator (DAM), which actively delay the expiration of timers during the resiliency phase of Modern Standby to simulate S3 sleep. However, some key system timer activity must still be permitted to periodically run even during this phase.

These three requirements led to the creation of enhanced timers, which are also internally known as Timer2 objects, and the creation of new system calls such as *NtCreateTimer2* and *NtSetTimer2*, as well as driver APIs such as *ExAllocateTimer* and *ExSetTimer*. Enhanced timers support four modes of behavior, some of which are mutually exclusive:

- **No-wake** This type of enhanced timer is an improvement over timer coalescing because it provides for a tolerable delay that is only used in periods of sleep.
- **High-resolution** This type of enhanced timer corresponds to a high-resolution timer with a precise clock rate that is dedicated to it. The clock rate will only need to run at this speed when approaching the expiration of the timer.
- **Idle-resilient** This type of enhanced timer is still active even during deep sleep, such as the resiliency phase of modern standby.
- **Finite** This is the type for enhanced timers that do not share one of the previously described properties.

High-resolution timers can also be idle resilient, and vice-versa. Finite timers, on the other hand, cannot have any of the described properties. Therefore, if finite enhanced timers do not have any "special" behavior, why create them at all? It turns out that since the new Timer2 infrastructure was a rewrite of the legacy timer logic that's been there since the start of the kernel's life, it includes a few other benefits regardless of any special functionality:

- It uses self-balancing red-black binary trees instead of the linked lists that form the timer table.
- It allows drivers to specify an enable and disable callback without worrying about manually creating DPCs.
- It includes new, clean, ETW tracing entries for each operation, aiding in troubleshooting.
- It provides additional security-in-depth through certain pointer obfuscation techniques and additional assertions, hardening against data-only exploits and corruption.

Therefore, driver developers that are only targeting Windows 8.1 and later are highly recommended to use the new enhanced timer infrastructure, even if they do not require the additional capabilities.



Note The documented *ExAllocateTimer* API does not allow drivers to create idle-resilient timers. In fact, such an attempt crashes the system. Only Microsoft inbox drivers can create such timers through the *ExAllocateTimerInternal* API. Readers are discouraged from attempting to use this API because the kernel maintains a static, hard-coded list of every known legitimate caller, tracked by a unique identifier that must be provided, and further has knowledge of how many such timers the component is allowed to create. Any violations result in a system crash (blue screen of death).

Enhanced timers also have a more complex set of expiration rules than regular timers because they end up having two possible *due times*. The first, called the *minimum due time*, specifies the earliest system clock time at which point the timer is allowed to expire. The second, *maximum due time*, is the latest system clock time at which the timer should ever expire. Windows guarantees that the timer will expire somewhere between these two points in time, either because of a regular clock tick every interval (such as 15 ms), or because of an ad-hoc check for timer expiration (such as the one that the idle thread does upon waking up from an interrupt). This interval is computed by taking the expected expiration time passed in by the developer and adjusting for the possible “no wake tolerance” that was passed in. If unlimited wake tolerance was specified, then the timer does not have a maximum due time.

As such, a *Timer2* object lives in potentially up to two red-black tree nodes—node 0, for the minimum due time checks, and node 1, for the maximum due time checks. No-wake and high-resolution timers live in node 0, while finite and idle-resilient timers live in node 1.

Since we mentioned that some of these attributes can be combined, how does this fit in with the two nodes? Instead of a single red-black tree, the system obviously needs to have more, which are called *collections* (see the public *KTIMER2_COLLECTION_INDEX* data structure), one for each type of enhanced timer we’ve seen. Then, a timer can be inserted into node 0 or node 1, or both, or neither, depending on the rules and combinations shown in Table 8-11.

TABLE 8-11 Timer types and node collection indices

Timer type	Node 0 collection index	Node 1 collection index
No-wake	<i>NoWake</i> , if it has a tolerance	<i>NoWake</i> , if it has a non-unlimited or no tolerance
Finite	Never inserted in this node	<i>Finite</i>
High-resolution	<i>Hr</i> , always	<i>Finite</i> , if it has a non-unlimited or no tolerance
Idle-resilient	<i>NoWake</i> , if it has a tolerance	<i>Ir</i> , if it has a non-unlimited or no tolerance
High-resolution & Idle-resilient	<i>Hr</i> , always	<i>Ir</i> , if it has a non-unlimited or no tolerance

Think of node 1 as the one that mirrors the default legacy timer behavior—every clock tick, check if a timer is due to expire. Therefore, a timer is guaranteed to expire as long as it’s in at least node 1, which implies that its minimum due time is the same as its maximum due time. If it has unlimited tolerance;

however, it won't be in node 1 because, technically, the timer could never expire if the CPU remains sleeping forever.

High-resolution timers are the opposite; they are checked exactly at the "right" time they're supposed to expire and never earlier, so node 0 is used for them. However, if their precise expiration time is "too early" for the check in node 0, they might be in node 1 as well, at which point they are treated like a regular (finite) timer (that is, they expire a little bit later than expected). This can also happen if the caller provided a tolerance, the system is idle, and there is an opportunity to coalesce the timer.

Similarly, an idle-resilient timer, if the system isn't in the resiliency phase, lives in the *NoWake* collection if it's not also high resolution (the default enhanced timer state) or lives in the *Hr* collection otherwise. However, on the clock tick, which checks node 1, it must be in the special *Ir* collection to recognize that the timer needs to execute even though the system is in deep sleep.

Although it may seem confusing at first, this state combination allows all legal combinations of timers to behave correctly when checked either at the system clock tick (node 1—enforcing a maximum due time) or at the next closest due time computation (node 0—enforcing a minimum due time).

As each timer is inserted into the appropriate collection (*KTIMER2_COLLECTION*) and associated red-black tree node(s), the collection's *next due time* is updated to be the earliest due time of any timer in the collection, whereas a global variable (*KiNextTimer2Due*) reflects the earliest due time of any timer in *any* collection.

EXPERIMENT: Listing enhanced system timers

You also can use the same kernel debugger shown earlier to display enhanced timers (Timer2's), which are shown at the bottom of the output:

```

KTIMER2s:
Address,          Due time,          Exp. Type  Callback, Attributes,
fffffa4840f6070b0 1825b8f1f4 [11/30/2020 20:50:16.089] (Interrupt) [None] NWF (1826ea1ef4
[11/30/2020 20:50:18.089])
fffffa483ff903e48 1825c45674 [11/30/2020 20:50:16.164] (Interrupt) [None] NW P (27ef6380)
fffffa483fd824960 1825dd19e8 [11/30/2020 20:50:16.326] (Interrupt) [None] NWF (1828d80a68
[11/30/2020 20:50:21.326])
fffffa48410c07eb8 1825e2d9c6 [11/30/2020 20:50:16.364] (Interrupt) [None] NW P (27ef6380)
fffffa483f75bde38 1825e6f8c4 [11/30/2020 20:50:16.391] (Interrupt) [None] NW P (27ef6380)
fffffa48407108e60 1825ec5ae8 [11/30/2020 20:50:16.426] (Interrupt) [None] NWF (1828e74b68
[11/30/2020 20:50:21.426])
fffffa483f7a194a0 1825fe1d10 [11/30/2020 20:50:16.543] (Interrupt) [None] NWF (18272f4a10
[11/30/2020 20:50:18.543])
fffffa483fd29a8f8 18261691e3 [11/30/2020 20:50:16.703] (Interrupt) [None] NW P (11e1a300)
fffffa483ffcc2660 18261707d3 [11/30/2020 20:50:16.706] (Interrupt) [None] NWF (18265bd903
[11/30/2020 20:50:17.157])
fffffa483f7a19e30 182619f439 [11/30/2020 20:50:16.725] (Interrupt) [None] NWF (182914e4b9
[11/30/2020 20:50:21.725])
fffffa483ff9cfe48 182745de01 [11/30/2020 20:50:18.691] (Interrupt) [None] NW P (11e1a300)
fffffa483f3cfe740 18276567a9 [11/30/2020 20:50:18.897] (Interrupt)
Wdf01000!FxTimer::_FxTimerExtCallbackThunk (Context @ fffffa483f3db7360) NWF
(1827fdfe29 [11/30/2020 20:50:19.897]) P (02faf080)

```

```

fffffa48404c02938 18276c5890 [11/30/2020 20:50:18.943] (Interrupt) [None] NW P (27ef6380)
fffffa483fde8e300 1827a0f6b5 [11/30/2020 20:50:19.288] (Interrupt) [None] NWF (183091c835
[11/30/2020 20:50:34.288])
fffffa483fde88580 1827d4fcb5 [11/30/2020 20:50:19.628] (Interrupt) [None] NWF (18290629b5
[11/30/2020 20:50:21.628])

```

In this example, you can mostly see No-wake (NW) enhanced timers, with their minimum due time shown. Some are periodic (P) and will keep being reinserted at expiration time. A few also have a maximum due time, meaning that they have a tolerance specified, showing you the latest time at which they might expire. Finally, one enhanced timer has a callback associated with it, owned by the Windows Driver Foundation (WDF) framework (see Chapter 6 of Part 1 for more information on WDF drivers).

System worker threads

During system initialization, Windows creates several threads in the System process, called *system worker threads*, which exist solely to perform work on behalf of other threads. In many cases, threads executing at DPC/dispatch level need to execute functions that can be performed only at a lower IRQL. For example, a DPC routine, which executes in an arbitrary thread context (because DPC execution can usurp any thread in the system) at DPC/dispatch level IRQL, might need to access paged pool or wait for a dispatcher object used to synchronize execution with an application thread. Because a DPC routine can't lower the IRQL, it must pass such processing to a thread that executes at an IRQL below DPC/dispatch level.

Some device drivers and executive components create their own threads dedicated to processing work at passive level; however, most use system worker threads instead, which avoids the unnecessary scheduling and memory overhead associated with having additional threads in the system. An executive component requests a system worker thread's services by calling the executive functions *ExQueueWorkItem* or *IoQueueWorkItem*. Device drivers should use only the latter (because this associates the work item with a Device object, allowing for greater accountability and the handling of scenarios in which a driver unloads while its work item is active). These functions place a *work item* on a queue dispatcher object where the threads look for work. (Queue dispatcher objects are described in more detail in the section "I/O completion ports" in Chapter 6 in Part 1.)

The *IoQueueWorkItemEx*, *IoSizeofWorkItem*, *IoInitializeWorkItem*, and *IoUninitializeWorkItem* APIs act similarly, but they create an association with a driver's Driver object or one of its Device objects.

Work items include a pointer to a routine and a parameter that the thread passes to the routine when it processes the work item. The device driver or executive component that requires passive-level execution implements the routine. For example, a DPC routine that must wait for a dispatcher object can initialize a work item that points to the routine in the driver that waits for the dispatcher object. At some stage, a system worker thread will remove the work item from its queue and execute the driver's routine. When the driver's routine finishes, the system worker thread checks to see whether there are more work items to process. If there aren't any more, the system worker thread blocks until a work item

is placed on the queue. The DPC routine might or might not have finished executing when the system worker thread processes its work item.

There are many types of system worker threads:

- *Normal worker threads* execute at priority 8 but otherwise behave like delayed worker threads.
- *Background worker threads* execute at priority 7 and inherit the same behaviors as normal worker threads.
- *Delayed worker threads* execute at priority 12 and process work items that aren't considered time-critical.
- *Critical worker threads* execute at priority 13 and are meant to process time-critical work items.
- *Super-critical worker threads* execute at priority 14, otherwise mirroring their critical counterparts.
- *Hyper-critical worker threads* execute at priority 15 and are otherwise just like other critical threads.
- *Real-time worker threads* execute at priority 18, which gives them the distinction of operating in the real-time scheduling range (see Chapter 4 of Part 1 for more information), meaning they are not subject to priority boosting nor regular time slicing.

Because the naming of all of these worker queues started becoming confusing, recent versions of Windows introduced *custom priority worker threads*, which are now recommended for all driver developers and allow the driver to pass in their own priority level.

A special kernel function, *ExpLegacyWorkerInitialization*, which is called early in the boot process, appears to set an initial number of delayed and critical worker queue threads, configurable through optional registry parameters. You may even have seen these details in an earlier edition of this book. Note, however, that these variables are there only for compatibility with external instrumentation tools and are not actually utilized by any part of the kernel on modern Windows 10 systems and later. This is because recent kernels implemented a new kernel dispatcher object, the *priority queue (KPRIQUEUE)*, coupled it with a fully dynamic number of kernel worker threads, and further split what used to be a single queue of worker threads into per-NUMA node worker threads.

On Windows 10 and later, the kernel dynamically creates additional worker threads as needed, with a default maximum limit of 4096 (see *ExpMaximumKernelWorkerThreads*) that can be configured through the registry up to a maximum of 16,384 threads and down to a minimum of 32. You can set this using the *MaximumKernelWorkerThreads* value under the registry key `HKLM\SYSTEM\CurrentControlSet\Control\Session Manager\Executive`.

Each partition object, which we described in Chapter 5 of Part 1, contains an *executive partition*, which is the portion of the partition object relevant to the executive—namely, the system worker thread logic. It contains a data structure tracking the *work queue manager* for each NUMA node part of the partition (a queue manager is made up of the deadlock detection timer, the work queue item reaper, and a handle to the actual thread doing the management). It then contains an array of pointers to each of the eight possible work queues (*EX_WORK_QUEUE*). These queues are associated with an individual index and track the number of minimum (guaranteed) and maximum threads, as well as how many work items have been processed so far.

Every system includes two default work queues: the *ExPool* queue and the *IoPool* queue. The former is used by drivers and system components using the *ExQueueWorkItem* API, whereas the latter is meant for *IoAllocateWorkItem*-type APIs. Finally, up to six more queues are defined for internal system use, meant to be used by the internal (non-exported) *ExQueueWorkItemToPrivatePool* API, which takes in a *pool identifier* from 0 to 5 (making up queue indices 2 to 7). Currently, only the memory manager's Store Manager (see Chapter 5 of Part 1 for more information) leverages this capability.

The executive tries to match the number of critical worker threads with changing workloads as the system executes. Whenever work items are being processed or queued, a check is made to see if a new worker thread might be needed. If so, an event is signaled, waking up the *ExpWorkQueueManagerThread* for the associated NUMA node and partition. An additional worker thread is created in one of the following conditions:

- There are fewer threads than the minimum number of threads for this queue.
- The maximum thread count hasn't yet been reached, all worker threads are busy, and there are pending work items in the queue, or the last attempt to try to queue a work item failed.

Additionally, once every second, for each worker queue manager (that is, for each NUMA node on each partition) the *ExpWorkQueueManagerThread* can also *try to* determine whether a deadlock may have occurred. This is defined as an increase in work items queued during the last interval without a matching increase in the number of work items processed. If this is occurring, an additional worker thread will be created, regardless of any maximum thread limits, hoping to clear out the potential deadlock. This detection will then be disabled until it is deemed necessary to check again (such as if the maximum number of threads has been reached). Since processor topologies can change due to *hot add* dynamic processors, the thread is also responsible for updating any affinities and data structures to keep track of the new processors as well.

Finally, once every double the *worker thread timeout* minutes (by default 10, so once every 20 minutes), this thread also checks if it should destroy any system worker threads. Through the same registry key, this can be configured to be between 2 and 120 minutes instead, using the value *WorkerThreadTimeoutInSeconds*. This is called *reaping* and ensures that system worker thread counts do not get out of control. A system worker thread is reaped if it has been waiting for a long time (defined as the worker thread timeout value) and no further work items are waiting to be processed (meaning the current number of threads are clearing them all out in a timely fashion).

EXPERIMENT: Listing system worker threads

Unfortunately, due to the per-partition reshuffling of the system worker thread functionality (which is no longer per-NUMA node as before, and certainly no longer global), the kernel debugger's **!exqueue** command can no longer be used to see a listing of system worker threads classified by their type and will error out.

Since the *EPARTITION*, *EX_PARTITION*, and *EX_WORK_QUEUE* data structures are all available in the public symbols, the debugger data model can be used to explore the queues and their

manager. For example, here is how you can look at the NUMA Node 0 worker thread manager for the main (default) system partition:

```
1kd> dx ((nt!_EX_PARTITION*)(*(nt!_EPARTITION**)&nt!PspSystemPartition)->ExPartition)->
    WorkQueueManagers[0]
((nt!_EX_PARTITION*)(*(nt!_EPARTITION**)&nt!PspSystemPartition)->ExPartition)->
    WorkQueueManagers[0]      : 0xfffffa483ede99d0 [Type: _EX_WORK_QUEUE_MANAGER *]
    [+0x000] Partition        : 0xfffffa483ede51090 [Type: _EX_PARTITION *]
    [+0x008] Node              : 0xfffff80467f24440 [Type: _ENODE *]
    [+0x010] Event             [Type: _KEVENT]
    [+0x028] DeadlockTimer     [Type: _KTIMER]
    [+0x068] ReaperEvent       [Type: _KEVENT]
    [+0x080] ReaperTimer       [Type: _KTIMER2]
    [+0x108] ThreadHandle      : 0xffffffff80000008 [Type: void *]
    [+0x110] ExitThread         : 0x0 [Type: unsigned long]
    [+0x114] ThreadSeed        : 0x1 [Type: unsigned short]
```

Alternatively, here is the ExPool for NUMA Node 0, which currently has 15 threads and has processed almost 4 million work items so far!

```
1kd> dx ((nt!_EX_PARTITION*)(*(nt!_EPARTITION**)&nt!PspSystemPartition)->ExPartition)->
    WorkQueues[0][0],d
((nt!_EX_PARTITION*)(*(nt!_EPARTITION**)&nt!PspSystemPartition)->ExPartition)->
    WorkQueues[0][0],d      : 0xfffffa483ede4dc70 [Type: _EX_WORK_QUEUE *]
    [+0x000] WorkPriQueue     [Type: _KPRIQUEUE]
    [+0x2b0] Partition        : 0xfffffa483ede51090 [Type: _EX_PARTITION *]
    [+0x2b8] Node              : 0xfffff80467f24440 [Type: _ENODE *]
    [+0x2c0] WorkItemsProcessed : 3942949 [Type: unsigned long]
    [+0x2c4] WorkItemsProcessedLastPass : 3931167 [Type: unsigned long]
    [+0x2c8] ThreadCount      : 15 [Type: long]
    [+0x2cc (30: 0)] MinThreads : 0 [Type: long]
    [+0x2cc (31:31)] TryFailed  : 0 [Type: unsigned long]
    [+0x2d0] MaxThreads        : 4096 [Type: long]
    [+0x2d4] QueueIndex        : ExPoolUntrusted (0) [Type: _EXQUEUEINDEX]
    [+0x2d8] AllThreadsExitedEvent : 0x0 [Type: _KEVENT *]
```

You could then look into the *ThreadList* field of the *WorkPriQueue* to enumerate the worker threads associated with this queue:

```
1kd> dx -r0 @$queue = ((nt!_EX_PARTITION*)(*(nt!_EPARTITION**)&nt!PspSystemPartition)->
    ExPartition)->WorkQueues[0][0]
@$queue = ((nt!_EX_PARTITION*)(*(nt!_EPARTITION**)&nt!PspSystemPartition)->ExPartition)->
    WorkQueues[0][0]      : 0xfffffa483ede4dc70 [Type: _EX_WORK_QUEUE *]

1kd> dx Debugger.Utility.Collections.FromListEntry(@$queue->WorkPriQueue.ThreadListHead,
    "nt!_KTHREAD", "QueueListEntry")
Debugger.Utility.Collections.FromListEntry(@$queue->WorkPriQueue.ThreadListHead,
    "nt!_KTHREAD", "QueueListEntry")
    [0x0] [Type: _KTHREAD]
    [0x1] [Type: _KTHREAD]
    [0x2] [Type: _KTHREAD]
    [0x3] [Type: _KTHREAD]
    [0x4] [Type: _KTHREAD]
    [0x5] [Type: _KTHREAD]
    [0x6] [Type: _KTHREAD]
```

```

[0x7]          [Type: _KTHREAD]
[0x8]          [Type: _KTHREAD]
[0x9]          [Type: _KTHREAD]
[0xa]          [Type: _KTHREAD]
[0xb]          [Type: _KTHREAD]
[0xc]          [Type: _KTHREAD]
[0xd]          [Type: _KTHREAD]
[0xe]          [Type: _KTHREAD]
[0xf]          [Type: _KTHREAD]

```

That was only the ExPool. Recall that the system also has an IoPool, which would be the next index (1) on this NUMA Node (0). You can also continue the experiment by looking at private pools, such as the Store Manager's pool.

```

!kd> dx ((nt!_EX_PARTITION*)(*(nt!_EPARTITION**)&nt!PspSystemPartition)->ExPartition)->
WorkQueues[0][1],d
((nt!_EX_PARTITION*)(*(nt!_EPARTITION**)&nt!PspSystemPartition)->ExPartition)->
WorkQueues[0][1],d      : 0xfffffa483ede77c50 [Type: _EX_WORK_QUEUE *]
[+0x000] WorkPriQueue    [Type: _KPRIQUEUE]
[+0x2b0] Partition      : 0xfffffa483ede51090 [Type: _EX_PARTITION *]
[+0x2b8] Node           : 0xfffff80467f24440 [Type: _ENODE *]
[+0x2c0] WorkItemsProcessed : 1844267 [Type: unsigned long]
[+0x2c4] WorkItemsProcessedLastPass : 1843485 [Type: unsigned long]
[+0x2c8] ThreadCount     : 5 [Type: long]
[+0x2cc (30: 0)] MinThreads      : 0 [Type: long]
[+0x2cc (31:31)] TryFailed       : 0 [Type: unsigned long]
[+0x2d0] MaxThreads      : 4096 [Type: long]
[+0x2d4] QueueIndex      : IoPoolUntrusted (1) [Type: _EXQUEUEINDEX]
[+0x2d8] AllThreadsExitedEvent : 0x0 [Type: _KEVENT *]

```

Exception dispatching

In contrast to interrupts, which can occur at any time, exceptions are conditions that result directly from the execution of the program that is running. Windows uses a facility known as *structured exception handling*, which allows applications to gain control when exceptions occur. The application can then fix the condition and return to the place the exception occurred, unwind the stack (thus terminating execution of the subroutine that raised the exception), or declare back to the system that the exception isn't recognized, and the system should continue searching for an exception handler that might process the exception. This section assumes you're familiar with the basic concepts behind Windows structured exception handling—if you're not, you should read the overview in the Windows API reference documentation in the Windows SDK or Chapters 23 through 25 in Jeffrey Richter and Christophe Nasarre's book *Windows via C/C++* (Microsoft Press, 2007) before proceeding. Keep in mind that although exception handling is made accessible through language extensions (for example, the `__try` construct in Microsoft Visual C++), it is a system mechanism and hence isn't language specific.

On the x86 and x64 processors, all exceptions have predefined interrupt numbers that directly correspond to the entry in the IDT that points to the trap handler for a particular exception. Table 8-12 shows x86-defined exceptions and their assigned interrupt numbers. Because the first entries of the IDT are used for exceptions, hardware interrupts are assigned entries later in the table, as mentioned earlier.

All exceptions, except those simple enough to be resolved by the trap handler, are serviced by a kernel module called the *exception dispatcher*. The exception dispatcher's job is to find an exception handler that can dispose of the exception. Examples of architecture-independent exceptions that the kernel defines include memory-access violations, integer divide-by-zero, integer overflow, floating-point exceptions, and debugger breakpoints. For a complete list of architecture-independent exceptions, consult the Windows SDK reference documentation.

TABLE 8-12 x86 exceptions and their interrupt numbers

Interrupt Number	Exception	Mnemonic
0	Divide Error	#DE
1	Debug (Single Step)	#DB
2	Non-Maskable Interrupt (NMI)	-
3	Breakpoint	#BP
4	Overflow	#OF
5	Bounds Check (Range Exceeded)	#BR
6	Invalid Opcode	#UD
7	NPX Not Available	#NM
8	Double Fault	#DF
9	NPX Segment Overrun	-
10	Invalid Task State Segment (TSS)	#TS
11	Segment Not Present	#NP
12	Stack-Segment Fault	#SS
13	General Protection	#GP
14	Page Fault	#PF
15	Intel Reserved	-
16	x87 Floating Point	#MF
17	Alignment Check	#AC
18	Machine Check	#MC
19	SIMD Floating Point	#XM or #XF
20	Virtualization Exception	#VE
21	Control Protection (CET)	#CP

The kernel traps and handles some of these exceptions transparently to user programs. For example, encountering a breakpoint while executing a program being debugged generates an exception, which the kernel handles by calling the debugger. The kernel handles certain other exceptions by returning an unsuccessful status code to the caller.

A few exceptions are allowed to filter back, untouched, to user mode. For example, certain types of memory-access violations or an arithmetic overflow generate an exception that the operating system

doesn't handle. 32-bit applications can establish *frame-based exception handlers* to deal with these exceptions. The term *frame-based* refers to an exception handler's association with a particular procedure activation. When a procedure is invoked, a *stack frame* representing that activation of the procedure is pushed onto the stack. A stack frame can have one or more exception handlers associated with it, each of which protects a particular block of code in the source program. When an exception occurs, the kernel searches for an exception handler associated with the current stack frame. If none exists, the kernel searches for an exception handler associated with the previous stack frame, and so on, until it finds a frame-based exception handler. If no exception handler is found, the kernel calls its own default exception handlers.

For 64-bit applications, structured exception handling does not use frame-based handlers (the frame-based technology has been proven to be attackable by malicious users). Instead, a table of handlers for each function is built into the image during compilation. The kernel looks for handlers associated with each function and generally follows the same algorithm we described for 32-bit code.

Structured exception handling is heavily used within the kernel itself so that it can safely verify whether pointers from user mode can be safely accessed for read or write access. Drivers can make use of this same technique when dealing with pointers sent during I/O control codes (IOCTLs).

Another mechanism of exception handling is called *vectored exception handling*. This method can be used only by user-mode applications. You can find more information about it in the Windows SDK or Microsoft Docs at <https://docs.microsoft.com/en-us/windows/win32/debug/vectored-exception-handling>.

When an exception occurs, whether it is explicitly raised by software or implicitly raised by hardware, a chain of events begins in the kernel. The CPU hardware transfers control to the kernel trap handler, which creates a trap frame (as it does when an interrupt occurs). The trap frame allows the system to resume where it left off if the exception is resolved. The trap handler also creates an exception record that contains the reason for the exception and other pertinent information.

If the exception occurred in kernel mode, the exception dispatcher simply calls a routine to locate a frame-based exception handler that will handle the exception. Because unhandled kernel-mode exceptions are considered fatal operating system errors, you can assume that the dispatcher always finds an exception handler. Some traps, however, do not lead into an exception handler because the kernel always assumes such errors to be fatal; these are errors that could have been caused only by severe bugs in the internal kernel code or by major inconsistencies in driver code (that could have occurred only through deliberate, low-level system modifications that drivers should not be responsible for). Such fatal errors will result in a bug check with the `UNEXPECTED_KERNEL_MODE_TRAP` code.

If the exception occurred in user mode, the exception dispatcher does something more elaborate. The Windows subsystem has a debugger port (this is actually a debugger object, which will be discussed later) and an exception port to receive notification of user-mode exceptions in Windows processes. (In this case, by "port" we mean an ALPC port object, which will be discussed later in this chapter.) The kernel uses these ports in its default exception handling, as illustrated in Figure 8-24.

Debugger breakpoints are common sources of exceptions. Therefore, the first action the exception dispatcher takes is to see whether the process that incurred the exception has an associated debugger

process. If it does, the exception dispatcher sends a debugger object message to the *debug object* associated with the process (which internally the system refers to as a “port” for compatibility with programs that might rely on behavior in Windows 2000, which used an LPC port instead of a debug object).

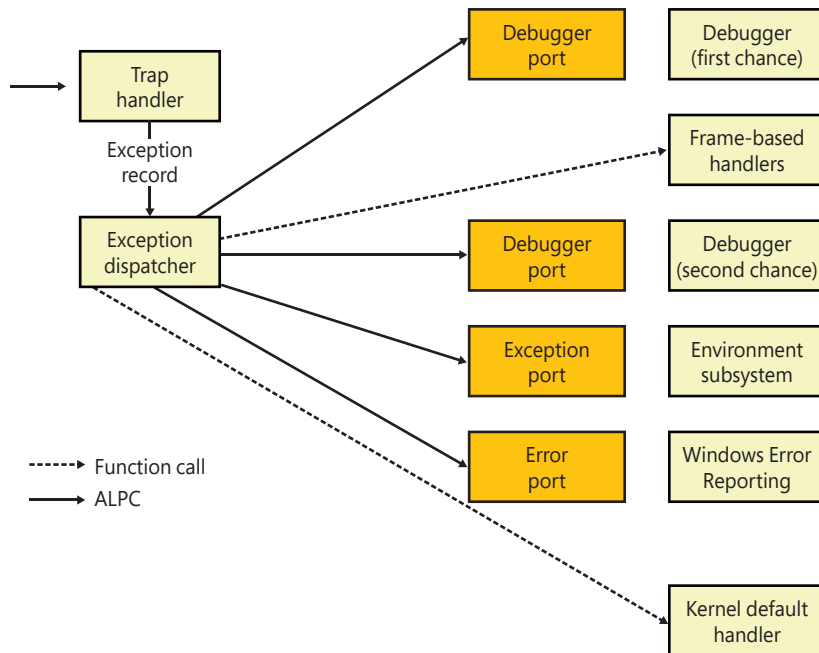

FIGURE 8-24 Dispatching an exception.

If the process has no debugger process attached or if the debugger doesn’t handle the exception, the exception dispatcher switches into user mode, copies the trap frame to the user stack formatted as a *CONTEXT* data structure (documented in the Windows SDK), and calls a routine to find a structured or vectored exception handler. If none is found or if none handles the exception, the exception dispatcher switches back into kernel mode and calls the debugger again to allow the user to do more debugging. (This is called the *second-chance notification*.)

If the debugger isn’t running and no user-mode exception handlers are found, the kernel sends a message to the exception port associated with the thread’s process. This exception port, if one exists, was registered by the environment subsystem that controls this thread. The exception port gives the environment subsystem, which presumably is listening at the port, the opportunity to translate the exception into an environment-specific signal or exception. However, if the kernel progresses this far in processing the exception and the subsystem doesn’t handle the exception, the kernel sends a message to a systemwide *error port* that Csrss (Client/Server Run-Time Subsystem) uses for Windows Error Reporting (WER)—which is discussed in Chapter 10—and executes a default exception handler that simply terminates the process whose thread caused the exception.

Unhandled exceptions

All Windows threads have an exception handler that processes unhandled exceptions. This exception handler is declared in the internal Windows *start-of-thread* function. The start-of-thread function runs when a user creates a process or any additional threads. It calls the environment-supplied thread start routine specified in the initial thread context structure, which in turn calls the user-supplied thread start routine specified in the *CreateThread* call.

The generic code for the internal start-of-thread functions is shown here:

```
VOID RtlUserThreadStart(VOID)
{
    LPVOID StartAddress = RCX; // Located in the initial thread context structure
    LPVOID Argument = RDX; // Located in the initial thread context structure
    LPVOID Win32StartAddr;
    if (Kernel32ThreadInitThunkFunction != NULL) {
        Win32StartAddr = Kernel32ThreadInitThunkFunction;
    } else {
        Win32StartAddr = StartAddress;
    }
    __try
    {
        DWORD ThreadExitCode = Win32StartAddr(Argument);
        RtlExitUserThread(ThreadExitCode);
    }
    __except(RtlpGetExceptionFilter(GetExceptionInformation()))
    {
        NtTerminateProcess(NtCurrentProcess(), GetExceptionCode());
    }
}
```

Notice that the Windows unhandled exception filter is called if the thread has an exception that it doesn't handle. The purpose of this function is to provide the system-defined behavior for what to do when an exception is not handled, which is to launch the WerFault.exe process. However, in a default configuration, the Windows Error Reporting service, described in Chapter 10, will handle the exception and this unhandled exception filter never executes.

EXPERIMENT: Viewing the real user start address for Windows threads

The fact that each Windows thread begins execution in a system-supplied function (and not the user-supplied function) explains why the start address for thread 0 is the same for every Windows process in the system (and why the start addresses for secondary threads are also the same). To see the user-supplied function address, use Process Explorer or the kernel debugger.

Because most threads in Windows processes start at one of the system-supplied wrapper functions, Process Explorer, when displaying the start address of threads in a process, skips the initial call frame that represents the wrapper function and instead shows the second frame on the stack. For example, notice the thread start address of a process running Notepad.exe:

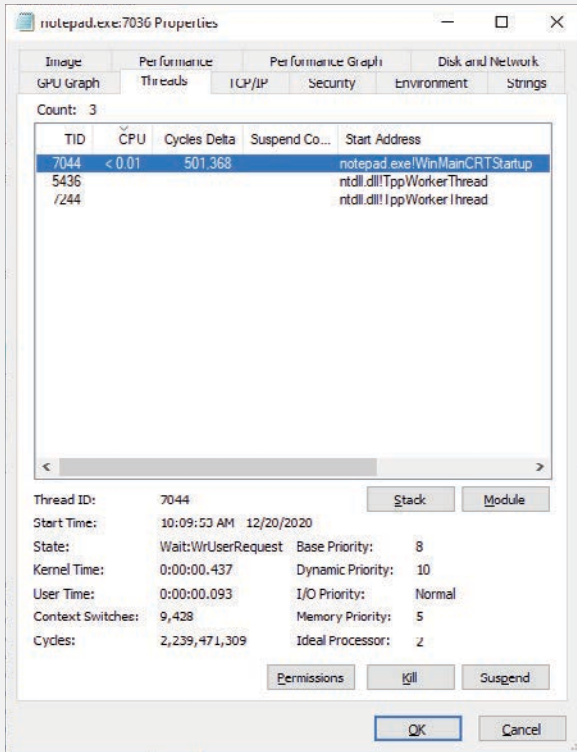

Process Explorer does display the complete call hierarchy when it displays the call stack. Notice the following results when the **Stack** button is clicked:

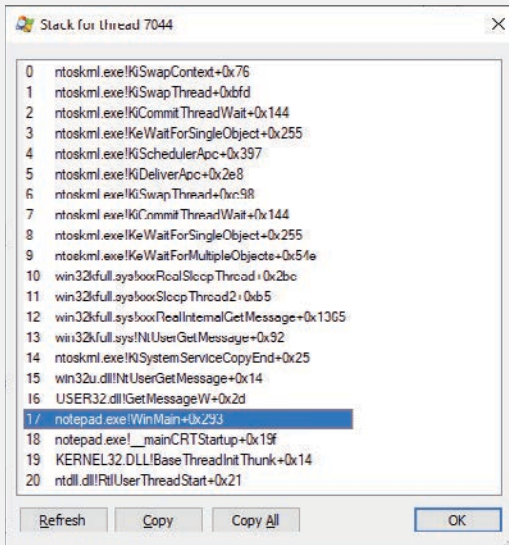

Line 20 in the preceding screen shot is the first frame on the stack—the start of the internal thread wrapper. The second frame (line 19) is the environment subsystem’s thread wrapper—in this case, kernel32, because you are dealing with a Windows subsystem application. The third frame (line 18) is the main entry point into Notepad.exe.

To show the correct function names, you should configure Process Explorer with the proper symbols. First you need to install the Debugging Tools, which are available in the Windows SDK or WDK. Then you should select the **Configure Symbols** menu item located in the **Options** menu. The dbghelp.dll path should point to the file located in the debugging tools folder (usually C:\Program Files\Windows Kits\10\Debuggers; note that the dbghelp.dll file located in C:\Windows\System32 would not work), and the Symbols path should be properly configured to download the symbols from the Microsoft symbols store in a local folder, as in the following figure:

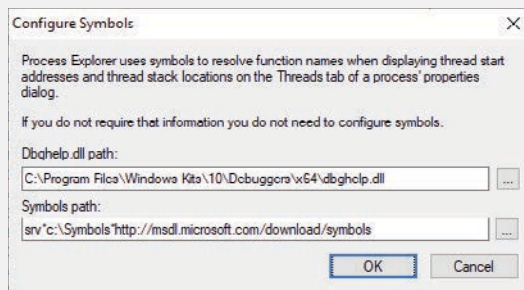

System service handling

As Figure 8-24 illustrated, the kernel’s trap handlers dispatch interrupts, exceptions, and system service calls. In the preceding sections, you saw how interrupt and exception handling work; in this section, you’ll learn about system services. A system service dispatch (shown in Figure 8-25) is triggered as a result of executing an instruction assigned to system service dispatching. The instruction that Windows uses for system service dispatching depends on the processor on which it is executing and whether Hypervisor Code Integrity (HVCI) is enabled, as you’re about to learn.

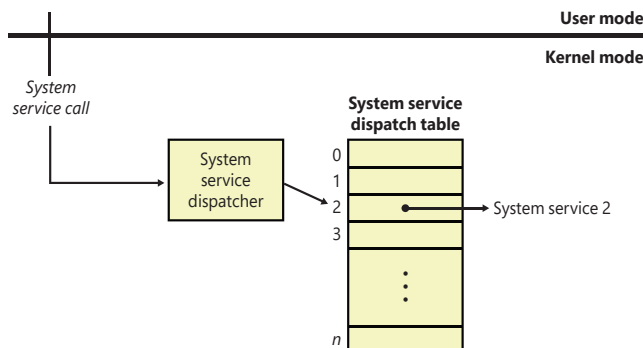

FIGURE 8-25 System service dispatching.

Architectural system service dispatching

On most x64 systems, Windows uses the *syscall* instruction, which results in the change of some of the key processor state we have learned about in this chapter, based on certain preprogrammed *model specific registers* (MSRs):

- 0xC0000081, known as STAR (SYSCALL Target Address Register)
- 0xC0000082, known as LSTAR (Long-Mode STAR)
- 0xC0000084, known as SFMASK (SYSCALL Flags Mask)

Upon encountering the *syscall* instruction, the processor acts in the following manner:

- The Code Segment (CS) is loaded from Bits 32 to 47 in STAR, which Windows sets to 0x0010 (KGDT64_R0_CODE).
- The Stack Segment (SS) is loaded from Bits 32 to 47 in STAR plus 8, which gives us 0x0018 (KGDT_R0_DATA).
- The Instruction Pointer (RIP) is saved in RCX, and the new value is loaded from LSTAR, which Windows sets to *KiSystemCall64* if the Meltdown (KVA Shadowing) mitigation is not needed, or *KiSystemCall64Shadow* otherwise. (More information on the Meltdown vulnerability was provided in the “Hardware side-channel vulnerabilities” section earlier in this chapter.)
- The current processor flags (RFLAGS) are saved in R11 and then masked with SFMASK, which Windows sets to 0x4700 (Trap Flag, Direction Flag, Interrupt Flag, and Nested Task Flag).
- The Stack Pointer (RSP) and all other segments (DS, ES, FS, and GS) are kept to their current user-space values.

Therefore, although the instruction executes in very few processor cycles, it does leave the processor in an insecure and unstable state—the user-mode stack pointer is still loaded, GS is still pointing to the TEB, but the Ring Level, or CPL, is now 0, enabling kernel mode privileges. Windows acts quickly to place the processor in a consistent operating environment. Outside of the KVA shadow-specific operations that might happen on legacy processors, these are the precise steps that *KiSystemCall64* must perform:

By using the *swaps* instruction, GS now points to the PCR, as described earlier in this chapter.

The current stack pointer (RSP) is saved into the *UserRsp* field of the PCR. Because GS has now correctly been loaded, this can be done without using any stack or register.

The new stack pointer is loaded from the *RspBase* field of the PRCB (recall that this structure is stored as part of the PCR).

Now that the kernel stack is loaded, the function builds a *trap frame*, using the format described earlier in the chapter. This includes storing in the frame the *SegSs* set to *KGDT_R3_DATA* (0x2B), *Rsp* from the *UserRsp* in the PCR, *EFlags* from R11, *SegCs* set to *KGDT_R3_CODE* (0x33), and storing *Rip* from RCX. Normally, a processor trap would’ve set these fields, but Windows must emulate the behavior based on how *syscall* operates.

Loading RCX from R10. Normally, the x64 ABI dictates that the first argument of any function (including a *syscall*) be placed in RCX—yet the *syscall* instruction overrides RCX with the instruction pointer of the caller, as shown earlier. Windows is aware of this behavior and copies RCX into R10 before issuing the *syscall* instruction, as you'll soon see, so this step restores the value.

The next steps have to do with processor mitigations such as Supervisor Mode Access Prevention (SMAP)—such as issuing the *stac* instruction—and the myriad processor side-channel mitigations, such as clearing the branch tracing buffers (BTB) or return store buffer (RSB). Additionally, on processors with Control-flow Enforcement Technology (CET), the shadow stack for the thread must also be synchronized correctly. Beyond this point, additional elements of the trap frame are stored, such as various nonvolatile registers and debug registers, and the nonarchitectural handling of the system call begins, which we discuss in more detail in just a bit.

Not all processors are x64, however, and it's worth pointing out that on x86 processors, for example, a different instruction is used, which is called *sysenter*. As 32-bit processors are increasingly rare, we don't spend too much time digging into this instruction other than mentioning that its behavior is similar—a certain amount of processor state is loaded from various MSRs, and the kernel does some additional work, such as setting up the trap frame. More details can be found in the relevant Intel processor manuals. Similarly, ARM-based processors use the *svc* instruction, which has its own behavior and OS-level handling, but these systems still represent only a small minority of Windows installations.

There is one more corner case that Windows must handle: processors without Mode Base Execution Controls (MBEC) operating while Hypervisor Code Integrity (HVCI) is enabled suffer from a design issue that violates the promises HVCI provides. (Chapter 9 covers HVCI and MBEC.) Namely, an attacker could allocate user-space executable memory, which HVCI allows (by marking the respective SLAT entry as executable), and then corrupt the PTE (which is not protected against kernel modification) to make the virtual address appear as a kernel page. Because the MMU would see the page as being kernel, Supervisor Mode Execution Prevention (SMEP) would not prohibit execution of the code, and because it was originally allocated as a user physical page, the SLAT entry wouldn't prohibit the execution either. The attacker has now achieved arbitrary kernel-mode code execution, violating the basic tenet of HVCI.

MBEC and its sister technologies (Restricted User Mode) fix this issue by introducing distinct kernel versus user executable bits in the SLAT entry data structures, allowing the hypervisor (or the Secure Kernel, through VTL1-specific hypercalls) to mark user pages as *kernel non executable* but *user executable*. Unfortunately, on processors without this capability, the hypervisor has no choice but to trap all code privilege level changes and swap between two different sets of SLAT entries—ones marking all user physical pages as nonexecutable, and ones marking them as executable. The hypervisor traps CPL changes by making the IDT appear empty (effectively setting its limit to 0) and decoding the underlying instruction, which is an expensive operation. However, as interrupts can directly be trapped by the hypervisor, avoiding these costs, the system call dispatch code in user space prefers issuing an interrupt if it detects an HVCI-enabled system without MBEC-like capabilities. The *SystemCall* bit in the Shared User Data structure described in Chapter 4, Part 1, is what determines this situation.

Therefore, when *SystemCall* is set to 1, x64 Windows uses the *int 0x2e* instruction, which results in a trap, including a fully built-out trap frame that does not require OS involvement. Interestingly, this happens to be the same instruction that was used on ancient x86 processors prior to the Pentium Pro,

and continues to still be supported on x86 systems for backward compatibility with three-decade-old software that had unfortunately hardcoded this behavior. On x64, however, *int 0x2e* can be used only in this scenario because the kernel will not fill out the relevant IDT entry otherwise.

Regardless of which instruction is ultimately used, the user-mode system call dispatching code always stores a *system call index* in a register—EAX on x86 and x64, R12 on 32-bit ARM, and X8 on ARM64—which will be further inspected by the nonarchitectural system call handling code we'll see next. And, to make things easy, the standard function call processor ABI (application binary interface) is maintained across the boundary—for example, arguments are placed on the stack on x86, and RCX (technically R10 due to the behavior of *syscall*), RDX, R8, R9 plus the stack for any arguments past the first four on x64.

Once dispatching completes, how does the processor return to its old state? For trap-based system calls that occurred through *int 0x2e*, the *iret* instruction restores the processor state based on the hardware trap frame on the stack. For *syscall* and *sysenter*, though, the processor once again leverages the MSRs and hardcoded registers we saw on entry, through specialized instructions called *sysret* and *sysexit*, respectively. Here's how the former behaves:

- The Stack Segment (SS) is loaded from bits 48 to 63 in STAR, which Windows sets to 0x0023 (*KGDT_R3_DATA*).
- The Code Segment (CS) is loaded from bits 48 to 63 in STAR plus 0x10, which gives us 0x0033 (*KGDT64_R3_CODE*).
- The Instruction Pointer (RIP) is loaded from RCX.
- The processor flags (RFLAGS) are loaded from R11.
- The Stack Pointer (RSP) and all other segments (DS, ES, FS, and GS) are kept to their current kernel-space values.

Therefore, just like for system call entry, the exit mechanics must also clean up some processor state. Namely, RSP is restored to the *Rsp* field that was saved on the manufactured hardware trap frame from the entry code we analyzed, similar to all the other saved registers. RCX register is loaded from the saved *Rip*, R11 is loaded from *EFlags*, and the *swaps* instruction is used right before issuing the *sysret* instruction. Because DS, ES, and FS were never touched, they maintain their original user-space values. Finally, EDX and XMM0 through XMM5 are zeroed out, and all other nonvolatile registers are restored from the trap frame before the *sysret* instruction. Equivalent actions are taken on for *sysexit* and ARM64's exit instruction (*eret*). Additionally, if CET is enabled, just like in the entry path, the shadow stack must correctly be synchronized on the exit path.

EXPERIMENT: Locating the system service dispatcher

As mentioned, x64 system calls occur based on a series of MSRs, which you can use the *rdmsr* debugger command to explore. First, take note of STAR, which shows *KGDT_R0_CODE* (0x0010) and *KGDT64_R3_DATA* (0x0023).

```
1kd> rdmsr c0000081
msr[c0000081] = 00230010`00000000
```

Next, you can investigate LSTAR, and then use the **ln** command to see if it's pointing to *KiSystemCall64* (for systems that don't require KVA Shadowing) or *KiSystemCall64Shadow* (for those that do):

```
1kd> rdmsr c0000082
msr[c0000082] = fffff804`7ebd3740

1kd> ln fffff804`7ebd3740
(fffff804`7ebd3740) nt!KiSystemCall64
```

Finally, you can look at SFMASK, which should have the values we described earlier:

```
1kd> rdmsr c0000084
msr[c0000084] = 00000000`00004700
```

x86 system calls occur through *sysenter*, which uses a different set of MSRs, including 0x176, which stores the 32-bit system call handler:

```
1kd> rdmsr 176
msr[176] = 00000000`8208c9c0

1kd> ln 00000000`8208c9c0
(8208c9c0) nt!KiFastCallEntry
```

Finally, on both x86 systems as well as x64 systems without MBEC but with HVCI, you can see the *int 0x2e* handler registered in the IDT with the **!idt 2e** debugger command:

```
1kd> !idt 2e

Dumping IDT: fffff8047af03000
2e:          fffff8047ebd3040 nt!KiSystemService
```

You can disassemble the *KiSystemService* or *KiSystemCall64* routine with the **u** command. For the interrupt handler, you'll eventually notice

```
nt!KiSystemService+0x227:
fffff804`7ebd3267 4883c408      add     rsp,8
fffff804`7ebd326b 0faee8       lfence
fffff804`7ebd326e 65c604255308000000 mov    byte ptr gs:[853h],0
fffff804`7ebd3277 e904070000    jmp    nt!KiSystemServiceUser (fffff804`7ebd3980)
```

while the MSR handler will fall in

```
nt!KiSystemCall64+0x227:
fffff804`7ebd3970 4883c408      add     rsp,8
fffff804`7ebd3974 0faee8       lfence
fffff804`7ebd3977 65c604255308000000 mov    byte ptr gs:[853h],0
nt!KiSystemServiceUser:
fffff804`7ebd3980 c645ab02     mov    byte ptr [rbp-55h],2
```

This shows you that eventually both code paths arrive in *KiSystemServiceUser*, which then does most common actions across all processors, as discussed in the next section.

Nonarchitectural system service dispatching

As Figure 8-25 illustrates, the kernel uses the system call number to locate the system service information in the *system service dispatch table*. On x86 systems, this table is like the interrupt dispatch table described earlier in the chapter except that each entry contains a pointer to a system service rather than to an interrupt-handling routine. On other platforms, including 32-bit ARM and ARM64, the table is implemented slightly differently; instead of containing pointers to the system service, it contains offsets relative to the table itself. This addressing mechanism is more suited to the x64 and ARM64 application binary interface (ABI) and instruction-encoding format, and the RISC nature of ARM processors in general.



Note System service numbers frequently change between OS releases. Not only does Microsoft occasionally add or remove system services, but the table is also often randomized and shuffled to break attacks that hardcode system call numbers to avoid detection.

Regardless of architecture, the system service dispatcher performs a few common actions on all platforms:

- Save additional registers in the trap frame, such as debug registers or floating-point registers.
- If this thread belongs to a pico process, forward to the system call pico provider routine (see Chapter 3, Part 1, for more information on pico providers).
- If this thread is an UMS scheduled thread, call *KiUmsCallEntry* to synchronize with the primary (see Chapter 1, Part 1, for an introduction on UMS). For UMS primary threads, set the *UmsPerformingSyscall* flag in the thread object.
- Save the first parameter of the system call in the *FirstArgument* field of the thread object and the system call number in *SystemCallNumber*.
- Call the shared user/kernel system call handler (*KiSystemServiceStart*), which sets the *TrapFrame* field of the thread object to the current stack pointer where it is stored.
- Enable interrupt delivery.

At this point, the thread is officially undergoing a system call, and its state is fully consistent and can be interrupted. The next step is to select the correct system call table and potentially upgrade the thread to a GUI thread, details of which will be based on the *GuiThread* and *RestrictedGuiThread* fields of the thread object, and which will be described in the next section. Following that, GDI Batching operations will occur for GUI threads, as long as the TEB's *GdiBatchCount* field is non-zero.

Next, the system call dispatcher must copy any of the caller's arguments that are not passed by register (which depends on the CPU architecture) from the thread's user-mode stack to its kernel-mode stack. This is needed to avoid having each system call manually copy the arguments (which would require assembly code and exception handling) and ensure that the user can't change the arguments as the kernel is accessing them. This operation is done within a special code block that is recognized by the exception handlers as being associated to user stack copying, ensuring that the kernel does not

crash in the case that an attacker, or incorrectly written program, is messing with the user stack. Since system calls can take an arbitrary number of arguments (well, almost), you see in the next section how the kernel knows how many to copy.

Note that this argument copying is *shallow*: If any of the arguments passed to a system service points to a buffer in user space, it must be *probed* for safe accessibility before kernel-mode code can read and/or write from it. If the buffer will be accessed multiple times, it may also need to be *captured*, or copied, into a local kernel buffer. The responsibility of this *probe and capture* operation lies with each individual system call and is not performed by the handler. However, one of the key operations that the system call dispatcher must perform is to set the *previous mode* of the thread. This value corresponds to either *KernelMode* or *UserMode* and must be synchronized whenever the current thread executes a trap, identifying the privilege level of the incoming exception, trap, or system call. This will allow the system call, using *ExGetPreviousMode*, to correctly handle user versus kernel callers.

Finally, two last steps are taken as part of the dispatcher's body. First, if DTrace is configured and system call tracing is enabled, the appropriate entry/exit callbacks are called around the system call. Alternatively, if ETW tracing is enabled but not DTrace, the appropriate ETW events are logged around the system call. Finally, if neither DTrace nor ETW are enabled, the system call is made without any additional logic. The second, and final, step is to increment the *KeSystemCalls* variable in the PRCB, which is exposed as a performance counter that you can track in the Performance & Reliability Monitor.

At this point, system call dispatching is complete, and the opposite steps will then be taken as part of *system call exit*. These steps will restore and copy user-mode state as appropriate, handle user-mode APC delivery as needed, address side-channel mitigations around various architectural buffers, and eventually return with one of the CPU instructions relevant for this platform.

Kernel-issued system call dispatching

Because system calls can be performed both by user-mode code and kernel mode, any pointers, handles, and behaviors should be treated as if coming from user mode—which is clearly not correct.

To solve this, the kernel exports specialized *Zw* versions of these calls—that is, instead of *NtCreateFile*, the kernel exports *ZwCreateFile*. Additionally, because *Zw* functions must be manually exported by the kernel, only the ones that Microsoft wishes to expose for third-party use are present. For example, *ZwCreateUserProcess* is not exported by name because kernel drivers are not expected to launch user applications. These exported APIs are not actually simple aliases or wrappers around the *Nt* versions. Instead, they are “trampolines” to the appropriate *Nt* system call, which use the same system call-dispatching mechanism.

Like *KiSystemCall64* does, they too build a fake hardware trap frame (pushing on the stack the data that the CPU would generate after an interrupt coming from kernel mode), and they also disable interrupts, just like a trap would. On x64 systems, for example, the *KGDT64_R0_CODE* (0x0010) selector is pushed as CS, and the current kernel stack as RSP. Each of the trampolines places the system call number in the appropriate register (for example, EAX on x86 and x64), and then calls *KiServiceInternal*, which saves additional data in the trap frame, reads the current previous mode, stores it in the trap frame, and then sets the previous mode to *KernelMode* (this is an important difference).

User-issued system call dispatching

As was already introduced in Chapter 1 of Part 1, the system service dispatch instructions for Windows executive services exist in the system library Ntdll.dll. Subsystem DLLs call functions in Ntdll to implement their documented functions. The exception is Windows USER and GDI functions, including DirectX Kernel Graphics, for which the system service dispatch instructions are implemented in Win32u.dll. Ntdll.dll is not involved. These two cases are shown in Figure 8-26.

As shown in the figure, the Windows *WriteFile* function in Kernel32.dll imports and calls the *WriteFile* function in API-MS-Win-Core-File-L1-1-0.dll, one of the MinWin redirection DLLs (see Chapter 3, Part 1, for more information on API redirection), which in turn calls the *WriteFile* function in KernelBase.dll, where the actual implementation lies. After some subsystem-specific parameter checks, it then calls the *NtWriteFile* function in Ntdll.dll, which in turn executes the appropriate instruction to cause a system service trap, passing the system service number representing *NtWriteFile*.

The system service dispatcher in Ntoskrnl.exe (in this example, *KiSystemService*) then calls the real *NtWriteFile* to process the I/O request. For Windows USER, GDI, and DirectX Kernel Graphics functions, the system service dispatch calls the function in the loadable kernel-mode part of the Windows subsystem, Win32k.sys, which might then filter the system call or forward it to the appropriate module, either Win32kbase.sys or Win32kfull.sys on Desktop systems, Win32kmin.sys on Windows 10X systems, or Dlxkrnl.sys if this was a DirectX call.

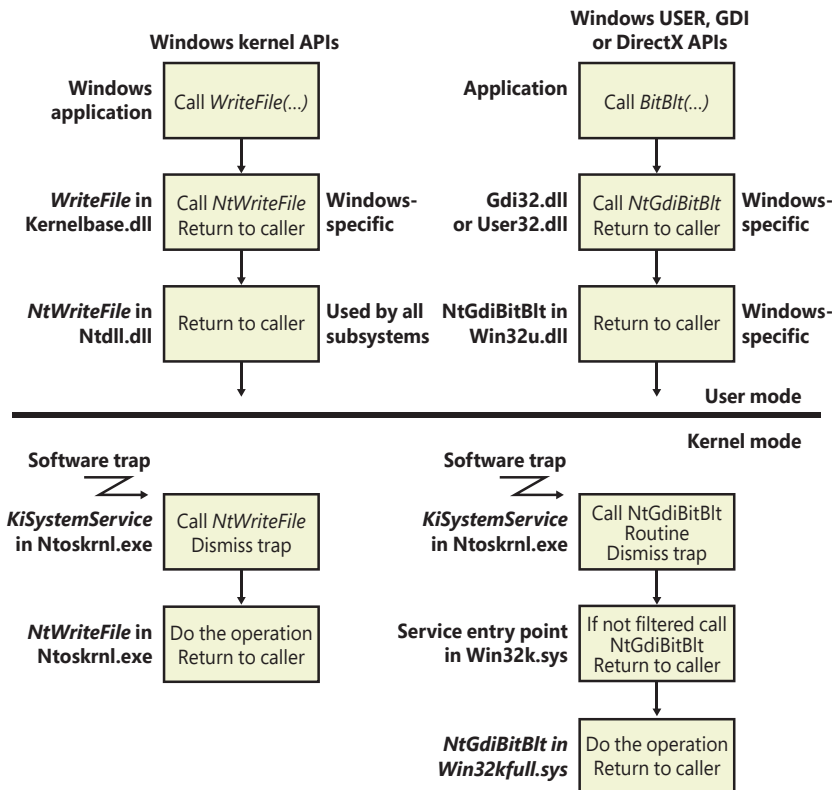

FIGURE 8-26 System service dispatching.

System call security

Since the kernel has the mechanisms that it needs for correctly synchronizing the previous mode for system call operations, each system call service can rely on this value as part of processing. We previously mentioned that these functions must first *probe* any argument that's a pointer to a user-mode buffer of any sort. By *probe*, we mean the following:

1. Making sure that the address is below *MmUserProbeAddress*, which is 64 KB below the highest user-mode address (such as 0x7FFF0000 on 32-bit).
2. Making sure that the address is aligned to a boundary matching how the caller intends to access its data—for example, 2 bytes for Unicode characters, 8 bytes for a 64-bit pointer, and so on.
3. If the buffer is meant to be used for output, making sure that, at the time the system call begins, it is actually writable.

Note that output buffers could become invalid or read-only at any future point in time, and the system call must always access them using SEH, which we described earlier in this chapter, to avoid crashing the kernel. For a similar reason, although input buffers aren't checked for readability, because they will likely be imminently used anyway, SEH must be used to ensure they can be safely read. SEH doesn't protect against alignment mismatches or wild kernel pointers, though, so the first two steps must still be taken.

It's obvious that the first check described above would fail for any kernel-mode caller right away, and this is the first part where previous mode comes in—probing is skipped for non-*UserMode* calls, and all buffers are assumed to be valid, readable and/or writable as needed. This isn't the only type of validation that a system call must perform, however, because some other dangerous situations can arise:

- The caller may have supplied a handle to an object. The kernel normally bypasses all security access checks when referencing objects, and it also has full access to kernel handles (which we describe later in the "Object Manager" section of this chapter), whereas user-mode code does not. The previous mode is used to inform the Object Manager that it should still perform access checks because the request came from user space.
- In even more complex cases, it's possible that flags such as *OBJ_FORCE_ACCESS_CHECK* need to be used by a driver to indicate that even though it is using the *Zw* API, which sets the previous mode to *KernelMode*, the Object Manager should still treat the request as if coming from *UserMode*.
- Similarly, the caller may have specified a file name. It's important for the system call, when opening the file, to potentially use the *IO_FORCE_ACCESS_CHECKING* flag, to force the security reference monitor to validate access to the file system, as otherwise a call such as *ZwCreateFile* would change the previous mode to *KernelMode* and bypass access checks. Potentially, a driver may also have to do this if it's creating a file on behalf of an IRP from user-space.
- File system access also brings risks with regard to symbolic links and other types of redirection attacks, where privileged kernel-mode code might be incorrectly using various process-specific/user-accessible reparse points.

- Finally, and in general, any operation that results in a chained system call, which is performed with the Zw interface, must keep in mind that this will reset the previous mode to *KernelMode* and respond accordingly.

Service descriptor tables

We previously mentioned that before performing a system call, the user-mode or kernel-mode trampolines will first place a system call number in a processor register such as RAX, R12, or X8. This number is technically composed of two elements, which are shown in Figure 8-27. The first element, stored in the bottom 12 bits, represents the system call *index*. The second, which uses the next higher 2 bits (12-13), is the *table identifier*. As you're about to see, this allows the kernel to implement up to four different types of system services, each stored in a table that can house up to 4096 system calls.

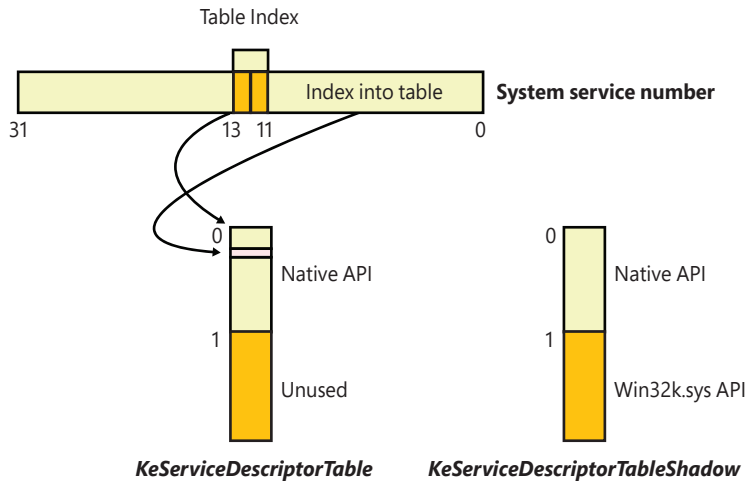

FIGURE 8-27 System service number to system service translation.

The kernel keeps track of the system service tables using three possible arrays—*KeServiceDescriptorTable*, *KeServiceDescriptorTableShadow*, and *KeServiceDescriptorTableFilter*. Each of these arrays can have up to two entries, which store the following three pieces of data:

- A pointer to the array of system calls implemented by this service table
- The number of system calls present in this service table, called the limit
- A pointer to the array of argument bytes for each of the system calls in this service table

The first array only ever has one entry, which points to *KiServiceTable* and *KiArgumentTable*, with a little over 450 system calls (the precise number depends on your version of Windows). All threads, by default, issue system calls that only access this table. On x86, this is enforced by the *ServiceTable* pointer in the thread object, while all other platforms hardcode the symbol *KeServiceDescriptorTable* in the system call dispatcher.

The first time that a thread makes a system call that's beyond the limit, the kernel calls *PsConvertToGuiThread*, which notifies the USER and GDI services in Win32k.sys about the thread and sets either the thread object's *GuiThread* flag or its *RestrictedGuiThread* flag after these return successfully. Which one is used depends on whether the *EnableFilteredWin32kSystemCalls* process mitigation option is enabled, which we described in the "Process-mitigation policies" section of Chapter 7, Part 1. On x86 systems, the thread object's *ServiceTable* pointer now changes to *KeServiceDescriptorTableShadow* or *KeServiceDescriptorTableFilter* depending on which of the flags is set, while on other platforms it is a hardcoded symbol chosen at each system call. (Although less performant, the latter avoids an obvious hooking point for malicious software to abuse.)

As you can probably guess, these other arrays include a second entry, which represents the Windows USER and GDI services implemented in the kernel-mode part of the Windows subsystem, Win32k.sys, and, more recently, the DirectX Kernel Subsystem services implemented by Ddxgkrnl.sys, albeit these still transit through Win32k.sys initially. This second entry points to *W32pServiceTable* or *W32pServiceTableFilter* and *W32pArgumentTable* or *W32pArgumentTableFilter*, respectively, and has about 1250 system calls or more, depending on your version of Windows.



Note Because the kernel does not link against Win32k.sys, it exports a *KeAddSystemServiceTable* function that allows the addition of an additional entry into the *KeServiceDescriptorTableShadow* and the *KeServiceDescriptorTableFilter* table if it has not already been filled out. If Win32k.sys has already called these APIs, the function fails, and PatchGuard protects the arrays once this function has been called, so that the structures effectively become read only.

The only material difference between the *Filter* entries is that they point to system calls in Win32k.sys with names like *stub_UserGetThreadState*, while the real array points to *NtUserGetThreadState*. The former stubs will check if Win32k.sys filtering is enabled for this system call, based, in part, on the filter set that's been loaded for the process. Based on this determination, they will either fail the call and return *STATUS_INVALID_SYSTEM_SERVICE* if the filter set prohibits it or end up calling the original function (such as *NtUserGetThreadState*), with potential telemetry if auditing is enabled.

The argument tables, on the other hand, are what help the kernel to know how many stack bytes need to be copied from the user stack into the kernel stack, as explained in the dispatching section earlier. Each entry in the argument table corresponds to the matching system call with that index and stores the count of bytes to copy (up to 255). However, kernels for platforms other than x86 employ a mechanism called *system call table compaction*, which combines the system call pointer from the call table with the byte count from the argument table into a single value. The feature works as follows:

1. Take the system call function pointer and compute the 32-bit difference from the beginning of the system call table itself. Because the tables are global variables inside of the same module that contains the functions, this range of ± 2 GB should be more than enough.

2. Take the stack byte count from the argument table and divide it by 4, converting it into an *argument count* (some functions might take 8-byte arguments, but for these purposes, they'll simply be considered as two "arguments").
3. Shift the 32-bit difference from the first step by 4 bits to the left, effectively making it a 28-bit difference (again, this is fine—no kernel component is more than 256 MB) and perform a *bit-wise or* operation to add the argument count from the second step.
4. Override the system call function pointer with the value obtained in step 3.

This optimization, although it may look silly at first, has a number of advantages: It reduces cache usage by not requiring two distinct arrays to be looked up during a system call, it simplifies the amount of pointer dereferences, and it acts as a layer of obfuscation, which makes it harder to hook or patch the system call table while making it easier for PatchGuard to defend it.

EXPERIMENT: Mapping system call numbers to functions and arguments

You can duplicate the same lookup performed by the kernel when dealing with a system call ID to figure out which function is responsible for handling it and how many arguments it takes. On an x86 system, you can just ask the debugger to dump each system call table, such as *KiServiceTable* with the **dps** command, which stands for *dump pointer symbol*, which will actually perform a lookup for you. You can then similarly dump the *KiArgumentTable* (or any of the Win32k.sys ones) with the **db** command or *dump bytes*.

A more interesting exercise, however, is dumping this data on an ARM64 or x64 system, due to the encoding we described earlier. The following steps will help you do that.

1. You can dump a specific system call by undoing the compaction steps described earlier. Take the base of the table and add it to the 28-bit offset that's stored at the desired index, as shown here, where system call 3 in the kernel's service table is revealed to be *NtMapUserPhysicalPagesScatter*:

```
1kd> ?? ((ULONG)(nt!KiServiceTable[3]) >> 4) + (int64)nt!KiServiceTable
unsigned int64 0xfffff803`1213e030
```

```
1kd> !n 0xfffff803`1213e030
(fffff803`1213e030) nt!NtMapUserPhysicalPagesScatter
```

2. You can see the number of stack-based 4-byte arguments this system call takes by taking the 4-bit argument count:

```
1kd> dx (((int*)&(nt!KiServiceTable))[3] & 0xF)
(((int*)&(nt!KiServiceTable))[3] & 0xF) : 0
```

3. Note that this doesn't mean the system call has no arguments. Because this is an x64 system, the call could take anywhere between 0 and 4 arguments, all of which are in registers (RCX, RDX, R8, and R9).

- You could also use the debugger data model to create a LINQ predicate using projection, dumping the entire table, leveraging the fact that the *KiServiceLimit* variable corresponds to the same limit field in the service descriptor table (just like *W32pServiceLimit* for the Win32k.sys entries in the shadow descriptor table). The output would look like this:

```

1kd> dx @$table = &nt!KiServiceTable
@$table = &nt!KiServiceTable : 0xffffffff8047ee24800 [Type: void *]

1kd> dx (((int(*)[90000])&(nt!KiServiceTable))>->Take(*(int*)&nt!KiServiceLimit)->
    Select(x => (x >> 4) + @$table)
(((int(*)[90000])&(nt!KiServiceTable))>->Take(*(int*)&nt!KiServiceLimit)->Select
    (x => (x >> 4) + @$table)
[0] : 0xffffffff8047eb081d0 [Type: void *]
[1] : 0xffffffff8047eb10940 [Type: void *]
[2] : 0xffffffff8047f0b7800 [Type: void *]
[3] : 0xffffffff8047f299f50 [Type: void *]
[4] : 0xffffffff8047f012450 [Type: void *]
[5] : 0xffffffff8047ebc5cc0 [Type: void *]
[6] : 0xffffffff8047f003b20 [Type: void *]

```

- You could use a more complex version of this command that would also allow you to convert the pointers into their symbolic forms, essentially reimplementing the **dps** command that works on x86 Windows:

```

1kd> dx @$symPrint = (x => Debugger.Utility.Control.ExecuteCommand(".printf \"%y\\n\"," +
    ((unsigned __int64)x).ToDisplayString("x")).First())
@$symPrint = (x => Debugger.Utility.Control.ExecuteCommand(".printf \"%y\\n\"," +
    ((unsigned __int64)x).ToDisplayString("x")).First())

1kd> dx (((int(*)[90000])&(nt!KiServiceTable))>->Take(*(int*)&nt!KiServiceLimit)->Select
    (x => @$symPrint((x >> 4) + @$table))
(((int(*)[90000])&(nt!KiServiceTable))>->Take(*(int*)&nt!KiServiceLimit)->Select(x =>
    @$symPrint((x >> 4) + @$table))
[0] : nt!NtAccessCheck (fffff804`7eb081d0)
[1] : nt!NtWorkerFactoryWorkerReady (fffff804`7eb10940)
[2] : nt!NtAcceptConnectPort (fffff804`7f0b7800)
[3] : nt!NtMapUserPhysicalPagesScatter (fffff804`7f299f50)
[4] : nt!NtWaitForSingleObject (fffff804`7f012450)
[5] : nt!NtCallbackReturn (fffff804`7ebc5cc0)

```

- Finally, as long as you're only interested in the kernel's service table and not the Win32k.sys entries, you can also use the **!chksvctbl -v** command in the debugger, whose output will include all of this data while also checking for inline hooks that a rootkit may have attached:

```

1kd> !chksvctbl -v
# ServiceTableEntry DecodedEntryTarget(Address) CompactedOffset
=====
0 0xffffffff8047ee24800 nt!NtAccessCheck(0xffffffff8047eb081d0) 0n-52191996
1 0xffffffff8047ee24804 nt!NtWorkerFactoryWorkerReady(0xffffffff8047eb10940) 0n-51637248
2 0xffffffff8047ee24808 nt!NtAcceptConnectPort(0xffffffff8047f0b7800) 0n43188226
3 0xffffffff8047ee2480c nt!NtMapUserPhysicalPagesScatter(0xffffffff8047f299f50) 0n74806528
4 0xffffffff8047ee24810 nt!NtWaitForSingleObject(0xffffffff8047f012450) 0n32359680

```

EXPERIMENT: Viewing system service activity

You can monitor system service activity by watching the System Calls/Sec performance counter in the System object. Run the Performance Monitor, click **Performance Monitor** under **Monitoring Tools**, and click the **Add** button to add a counter to the chart. Select the **System** object, select the **System Calls/Sec** counter, and then click the **Add** button to add the counter to the chart.

You'll probably want to change the maximum to a much higher value, as it's normal for a system to have hundreds of thousands of system calls a second, especially the more processors the system has. The figure below shows what this data looked like on the author's computer.

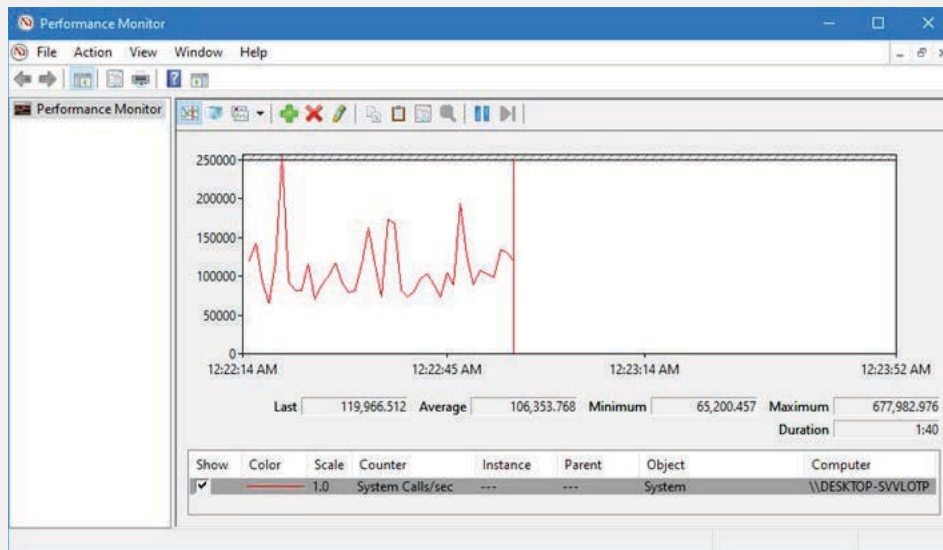

WoW64 (Windows-on-Windows)

WoW64 (Win32 emulation on 64-bit Windows) refers to the software that permits the execution of 32-bit applications on 64-bit platforms (which can also belong to a different architecture). WoW64 was originally a research project for running x86 code in old alpha and MIPS version of Windows NT 3.51. It has drastically evolved since then (that was around the year 1995). When Microsoft released Windows XP 64-bit edition in 2001, WoW64 was included in the OS for running old x86 32-bit applications in the new 64-bit OS. In modern Windows releases, WoW64 has been expanded to support also running ARM32 applications and x86 applications on ARM64 systems.

WoW64 core is implemented as a set of user-mode DLLs, with some support from the kernel for creating the target's architecture versions of what would normally only be 64-bit native data structures, such as the process environment block (PEB) and thread environment block (TEB). Changing WoW64 contexts through *Get/SetThreadContext* is also implemented by the kernel. Here are the core user-mode DLLs responsible for WoW64:

- **Wow64.dll** Implements the WoW64 core in user mode. Creates the thin software layer that acts as a kind of intermediary kernel for 32-bit applications and starts the simulation. Handles CPU context state changes and base system calls exported by Ntoskrnl.exe. It also implements file-system redirection and registry redirection.
- **Wow64win.dll** Implements thunking (conversion) for GUI system calls exported by Win32k.sys. Both Wow64win.dll and Wow64.dll include *thunking* code, which converts a calling convention from an architecture to another one.

Some other modules are architecture-specific and are used for translating machine code that belongs to a different architecture. In some cases (like for ARM64) the machine code needs to be emulated or jitted. In this book, we use the term *jitting* to refer to the just-in-time compilation technique that involves compilation of small code blocks (called compilation units) at runtime instead of emulating and executing one instruction at a time.

Here are the DLLs that are responsible in translating, emulating, or jitting the machine code, allowing it to be run by the target operating system:

- **Wow64cpu.dll** Implements the CPU simulator for running x86 32-bit code in AMD64 operating systems. Manages the 32-bit CPU context of each running thread inside WoW64 and provides processor architecture-specific support for switching CPU mode from 32-bit to 64-bit and vice versa.
- **Wowarmhw.dll** Implements the CPU simulator for running ARM32 (AArch32) applications on ARM64 systems. It represents the ARM64 equivalent of the Wow64cpu.dll used in x86 systems.
- **Xtajit.dll** Implements the CPU emulator for running x86 32-bit applications on ARM64 systems. Includes a full x86 emulator, a jitter (code compiler), and the communication protocol between the jitter and the XTA cache server. The jitter can create compilation blocks including ARM64 code translated from the x86 image. Those blocks are stored in a local cache.

The relationship of the WoW64 user-mode libraries (together with other core WoW64 components) is shown in Figure 8-28.

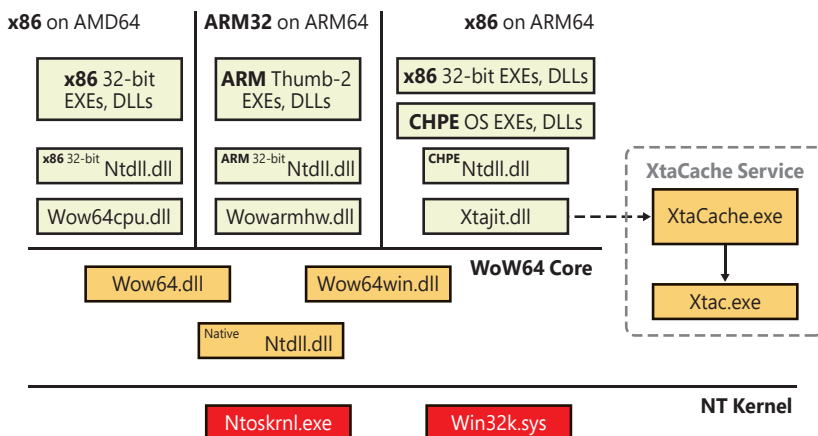

FIGURE 8-28 The WoW64 architecture.



Note Older Windows versions designed to run in Itanium machines included a full x86 emulator integrated in the WoW64 layer called Wowia32x.dll. Itanium processors were not able to natively execute x86 32-bit instructions in an efficient manner, so an emulator was needed. The Itanium architecture was officially discontinued in January 2019.

A newer Insider release version of Windows also supports executing 64-bit x86 code on ARM64 systems. A new jitter has been designed for that reason. However emulating AMD64 code in ARM systems is not performed through WoW64. Describing the architecture of the AMD64 emulator is outside the scope of this release of this book.

The WoW64 core

As introduced in the previous section, the WoW64 core is platform independent: It creates a software layer for managing the execution of 32-bit code in 64-bit operating systems. The actual translation is performed by another component called Simulator (also known as Binary Translator), which is platform specific. In this section, we will discuss the role of the WoW64 core and how it interoperates with the Simulator. While the core of WoW64 is almost entirely implemented in user mode (in the Wow64.dll library), small parts of it reside in the NT kernel.

WoW64 core in the NT kernel

During system startup (phase 1), the I/O manager invokes the *PsLocateSystemDlls* routine, which maps all the system DLLs supported by the system (and stores their base addresses in a global array) in the System process user address space. This also includes WoW64 versions of Ntdll, as described by Table 8-13. Phase 2 of the process manager (PS) startup resolves some entry points of those DLLs, which are stored in internal kernel variables. One of the exports, *LdrSystemDllInitBlock*, is used to transfer WoW64 information and function pointers to new WoW64 processes.

TABLE 8-13 Different Ntdll version list

Path	Internal Name	Description
c:\windows\system32\ntdll.dll	ntdll.dll	The system Ntdll mapped in every user process (except for minimal processes). This is the only version marked as required.
c:\windows\SysWow64\ntdll.dll	ntdll32.dll	32-bit x86 Ntdll mapped in WoW64 processes running in 64-bit x86 host systems.
c:\windows\SysArm32\ntdll.dll	ntdll32.dll	32-bit ARM Ntdll mapped in WoW64 processes running in 64-bit ARM host systems.
c:\windows\SyChpe32\ntdll.dll	ntdllwow.dll	32-bit x86 CHPE Ntdll mapped in WoW64 processes running in 64-bit ARM host systems.

When a process is initially created, the kernel determines whether it would run under WoW64 using an algorithm that analyzes the main process executable PE image and checks whether the correct Ntdll version is mapped in the system. In case the system has determined that the process is WoW64, when the kernel initializes its address space, it maps both the native Ntdll and the correct WoW64 version.

As explained in Chapter 3 of Part 1, each nonminimal process has a *PEB* data structure that is accessible from user mode. For WoW64 processes, the kernel also allocates the 32-bit version of the PEB and stores a pointer to it in a small data structure (*EWoW64PROCESS*) linked to the main *EPROCESS* representing the new process. The kernel then fills the data structure described by the 32-bit version of the *LdrSystemDllInitBlock* symbol, including pointers of Wow64 Ntdll exports.

When a thread is allocated for the process, the kernel goes through a similar process: along with the thread initial user stack (its initial size is specified in the PE header of the main image), another stack is allocated for executing 32-bit code. The new stack is called the thread's WoW64 stack. When the thread's TEB is built, the kernel will allocate enough memory to store both the 64-bit TEB, followed by a 32-bit TEB.

Furthermore, a small data structure (called WoW64 CPU Area Information) is allocated at the base of the 64-bit stack. The latter is composed of the target images machine identifier, a platform-dependent 32-bit CPU context (*X86_NT5_CONTEXT* or *ARM_CONTEXT* data structures, depending on the target architecture), and a pointer of the per-thread WoW64 CPU shared data, which can be used by the Simulator. A pointer to this small data structure is stored also in the thread's TLS slot 1 for fast referencing by the binary translator. Figure 8-29 shows the final configuration of a WoW64 process that contains an initial single thread.

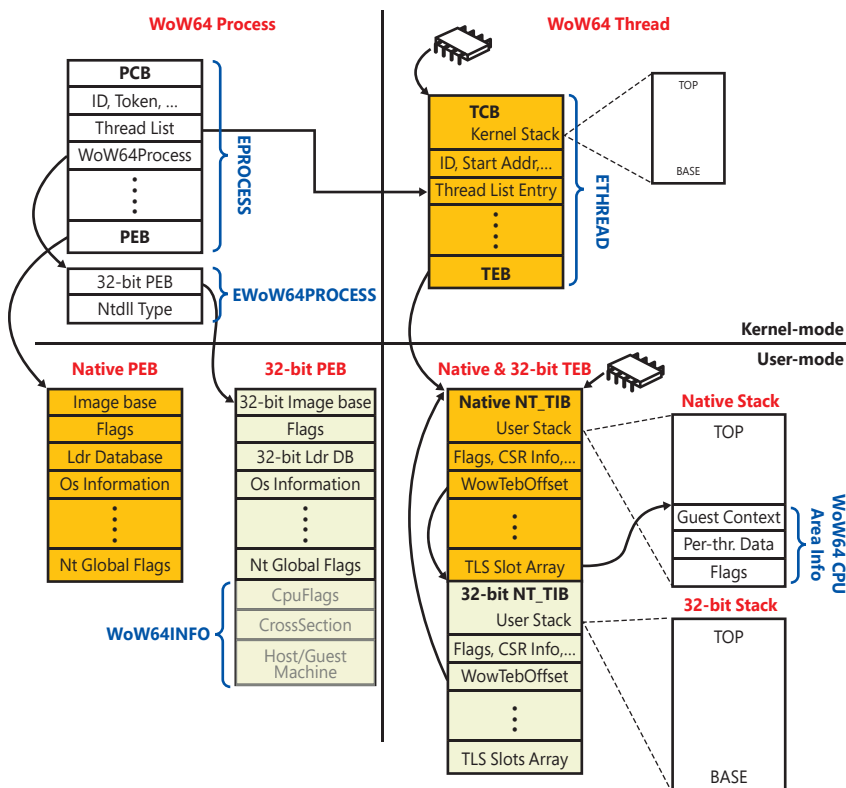

FIGURE 8-29 Internal configuration of a WoW64 process with only a single thread.

User-mode WoW64 core

Aside from the differences described in the previous section, the birth of the process and its initial thread happen in the same way as for non-WoW64 processes, until the main thread starts its execution by invoking the loader initialization function, *LdrpInitialize*, in the native version of Ntdll. When the loader detects that the thread is the first to be executed in the context of the new process, it invokes the process initialization routine, *LdrpInitializeProcess*, which, along with a lot of different things (see the “Early process initialization” section of Chapter 3 in Part 1 for further details), determines whether the process is a WoW64 one, based on the presence of the 32-bit TEB (located after the native TEB and linked to it). In case the check succeeded, the native Ntdll sets the internal *UseWoW64* global variable to 1, builds the path of the WoW64 core library, *wow64.dll*, and maps it above the 4 GB virtual address space limit (in that way it can’t interfere with the simulated 32-bit address space of the process.) It then gets the address of some WoW64 functions that deal with process/thread suspension and APC and exception dispatching and stores them in some of its internal variables.

When the process initialization routine ends, the Windows loader transfers the execution to the WoW64 Core via the exported *Wow64LdrpInitialize* routine, which will never return. From now on, each new thread starts through that entry point (instead of the classical *RtlUserThreadStart*). The WoW64 core obtains a pointer to the CPU WoW64 area stored by the kernel at the TLS slot 1. In case the thread is the first of the process, it invokes the WoW64 process initialization routine, which performs the following steps:

1. Tries to load the WoW64 Thunk Logging DLL (*wow64log.dll*). The DLL is used for logging WoW64 calls and is not included in commercial Windows releases, so it is simply skipped.
2. Looks up the Ntdll32 base address and function pointers thanks to the *LdrSystemDllInitBlock* filled by the NT kernel.
3. Initializes the files system and registry redirection. File system and registry redirection are implemented in the Syscall layer of WoW64 core, which intercepts 32-bit registry and files system requests and translates their path before invoking the native system calls.
4. Initializes the WoW64 service tables, which contains pointers to system services belonging to the NT kernel and Win32k GUI subsystem (similar to the standard kernel system services), but also Console and NLS service call (both WoW64 system service calls and redirection are covered later in this chapter.)
5. Fills the 32-bit version of the process’s PEB allocated by the NT kernel and loads the correct CPU simulator, based on the process main image’s architecture. The system queries the “default” registry value of the *HKLM\SOFTWARE\Microsoft\Wow64\<arch>* key (where *<arch>* can be *x86* or *arm*, depending on the target architecture), which contains the simulator’s main DLL name. The simulator is then loaded and mapped in the process’s address space. Some of its exported functions are resolved and stored in an internal array called *BtFuncs*. The array is the key that links the platform-specific binary translator to the WoW64 subsystem: WoW64 invokes simulator’s functions only through it. The *BtCpuProcessInit* function, for example, represents the simulator’s process initialization routine.

6. The thunking cross-process mechanism is initialized by allocating and mapping a 16 KB shared section. A synthesized work item is posted on the section when a WoW64 process calls an API targeting another 32-bit process (this operation propagates thunk operations across different processes).
7. The WoW64 layer informs the simulator (by invoking the exported *BtCpuNotifyMapViewOfSection*) that the main module, and the 32-bit version of Ntdll have been mapped in the address space.
8. Finally, the WoW64 core stores a pointer to the 32-bit system call dispatcher into the *Wow64Transition* exported variable of the 32-bit version of Ntdll. This allows the system call dispatcher to work.

When the process initialization routine ends, the thread is ready to start the CPU simulation. It invokes the Simulator's thread initialization function and prepares the new 32-bit context, translating the 64-bit one initially filled by the NT kernel. Finally, based on the new context, it prepares the 32-bit stack for executing the 32-bit version of the *LdrInitializeThunk* function. The simulation is started via the simulator's *BTCpuSimulate* exported function, which will never return to the caller (unless a critical error in the simulator happens).

File system redirection

To maintain application compatibility and to reduce the effort of porting applications from Win32 to 64-bit Windows, system directory names were kept the same. Therefore, the `\Windows\System32` folder contains native 64-bit images. WoW64, as it intercepts all the system calls, translates all the path related APIs and replaces various system paths with the WoW64 equivalent (which depends on the target process's architecture), as listed in Table 8-14. The table also shows paths redirected through the use of system environment variables. (For example, the `%PROGRAMFILES%` variable is also set to `\Program Files (x86)` for 32-bit applications, whereas it is set to the `\Program Files` folder for 64-bit applications.)

TABLE 8-14 WoW64 redirected paths

Path	Architecture	Redirected Location
c:\windows\system32	X86 on AMD64	C:\Windows\SysWow64
	X86 on ARM64	C:\Windows\SyChpe32 (or C:\Windows\SysWow64 if the target file does not exist in SyChpe32)
	ARM32	C:\Windows\SysArm32
%ProgramFiles%	Native	C:\Program Files
	X86	C:\Program Files (x86)
	ARM32	C:\Program Files (Arm)
%CommonProgramFiles%	Native	C:\Program Files\Common Files
	X86	C:\Program Files (x86)
	ARM32	C:\Program Files (Arm)\Common Files

C:\Windows\regedit.exe	X86	C:\Windows\SysWow64\regedit.exe
	ARM32	C:\Windows\SysArm32\regedit.exe
C:\Windows\LastGood\System32	X86	C:\Windows\LastGood\SysWow64
	ARM32	C:\Windows\LastGood\SysArm32

There are a few subdirectories of `\Windows\System32` that, for compatibility and security reasons, are exempted from being redirected such that access attempts to them made by 32-bit applications actually access the real one. These directories include the following:

- `%windir%\system32\catroot` and `%windir%\system32\catroot2`
- `%windir%\system32\driverstore`
- `%windir%\system32\drivers\etc`
- `%windir%\system32\hostdriverstore`
- `%windir%\system32\logfiles`
- `%windir%\system32\spool`

Finally, WoW64 provides a mechanism to control the file system redirection built into WoW64 on a per-thread basis through the *Wow64DisableWow64FsRedirection* and *Wow64RevertWow64FsRedirection* functions. This mechanism works by storing an enabled/disabled value on the TLS index 8, which is consulted by the internal *Wow64 RedirectPath* function. However, the mechanism can have issues with delay-loaded DLLs, opening files through the common file dialog and even internationalization—because once redirection is disabled, the system no longer uses it during internal loading either, and certain 64-bit-only files would then fail to be found. Using the `%SystemRoot%\Sysnative` path or some of the other consistent paths introduced earlier is usually a safer methodology for developers to use.



Note Because certain 32-bit applications might indeed be aware and able to deal with 64-bit images, a virtual directory, `\Windows\Sysnative`, allows any I/Os originating from a 32-bit application to this directory to be exempted from file redirection. This directory doesn't actually exist—it is a virtual path that allows access to the real `System32` directory, even from an application running under WoW64.

Registry redirection

Applications and components store their configuration data in the registry. Components usually write their configuration data in the registry when they are registered during installation. If the same component is installed and registered both as a 32-bit binary and a 64-bit binary, the last component registered will override the registration of the previous component because they both write to the same location in the registry.

To help solve this problem transparently without introducing any code changes to 32-bit components, the registry is split into two portions: Native and WoW64. By default, 32-bit components access the 32-bit view, and 64-bit components access the 64-bit view. This provides a safe execution environment for 32-bit and 64-bit components and separates the 32-bit application state from the 64-bit one, if it exists.

As discussed later in the “System calls” section, the WoW64 system call layer intercepts all the system calls invoked by a 32-bit process. When WoW64 intercepts the registry system calls that open or create a registry key, it translates the key path to point to the WoW64 view of the registry (unless the caller explicitly asks for the 64-bit view.) WoW64 can keep track of the redirected keys thanks to multiple tree data structures, which store a list of shared and split registry keys and subkeys (an anchor tree node defines where the system should begin the redirection). WoW64 redirects the registry at these points:

- HKLM\SOFTWARE
- HKEY_CLASSES_ROOT

Not the entire hive is split. Subkeys belonging to those root keys can be stored in the private WoW64 part of the registry (in this case, the subkey is a split key). Otherwise, the subkey can be kept shared between 32-bit and 64-bit apps (in this case, the subkey is a shared key). Under each of the split keys (in the position tracked by an anchor node), WoW64 creates a key called *Wow6432Node* (for x86 application) or *WowAA32Node* (for ARM32 applications). Under this key is stored 32-bit configuration information. All other portions of the registry are shared between 32-bit and 64-bit applications (for example, HKLM\SYSTEM).

As extra help, if an x86 32-bit application writes a REG_SZ or REG_EXPAND_SZ value that starts with the data “%ProgramFiles%” or %CommonProgramFiles%” to the registry, WoW64 modifies the actual values to “%ProgramFiles(x86)%” and %CommonProgramFiles(x86)%” to match the file system redirection and layout explained earlier. The 32-bit application must write exactly these strings using this case—any other data will be ignored and written normally.

For applications that need to explicitly specify a registry key for a certain view, the following flags on the *RegOpenKeyEx*, *RegCreateKeyEx*, *RegOpenKeyTransacted*, *RegCreateKeyTransacted*, and *RegDeleteKeyEx* functions permit this:

- **KEY_WoW64_64KEY** Explicitly opens a 64-bit key from either a 32-bit or 64-bit application and disables the REG_SZ or REG_EXPAND_SZ interception explained earlier
- **KEY_WoW64_32KEY** Explicitly opens a 32-bit key from either a 32-bit or 64-bit application

X86 simulation on AMD64 platforms

The interface of the x86 simulator for AMD64 platforms (*Wow64cpu.dll*) is pretty simple. The simulator process initialization function enables the fast system call interface, depending on the presence of software MBEC (Mode Based Execute Control is discussed in Chapter 9). When the WoW64 core starts the simulation by invoking the *BtCpuSimulate* simulator’s interface, the simulator builds the WoW64 stack frame (based on the 32-bit CPU context provided by the WoW64 core), initializes the Turbo thunks

array for dispatching fast system calls, and prepares the FS segment register to point to the thread's 32-bit TEB. It finally sets up a call gate targeting a 32-bit segment (usually the segment 0x20), switches the stacks, and emits a far jump to the final 32-bit entry point (at the first execution, the entry point is set to the 32-bit version of the *LdrInitializeThunk* loader function). When the CPU executes the far jump, it detects that the call gate targets a 32-bit segment, thus it changes the CPU execution mode to 32-bit. The code execution exits 32-bit mode only in case of an interrupt or a system call being dispatched. More details about call gates are available in the Intel and AMD software development manuals.



Note During the first switch to 32-bit mode, the simulator uses the IRET opcode instead of a far call. This is because all the 32-bit registers, including volatile registers and EFLAGS, need to be initialized.

System calls

For 32-bit applications, the WoW64 layer acts similarly to the NT kernel: special 32-bit versions of Ntdll.dll, User32.dll, and Gdi32.dll are located in the \Windows\Syswow64 folder (as well as certain other DLLs that perform interprocess communication, such as Rpcrt4.dll). When a 32-bit application requires assistance from the OS, it invokes functions located in the special 32-bit versions of the OS libraries. Like their 64-bit counterparts, the OS routines can perform their job directly in user mode, or they can require assistance from the NT kernel. In the latter case, they invoke system calls through stub functions like the one implemented in the regular 64-bit Ntdll. The stub places the system call index into a register, but, instead of issuing the native 32-bit system call instruction, it invokes the WoW64 system call dispatcher (through the *Wow64Transition* variable compiled by the WoW64 core).

The WoW64 system call dispatcher is implemented in the platform-specific simulator (*wow64cpu.dll*). It emits another far jump for transitioning to the native 64-bit execution mode, exiting from the simulation. The binary translator switches the stack to the 64-bit one and saves the old CPU's context. It then captures the parameters associated with the system call and converts them. The conversion process is called "thinking" and allows machine code executed following the 32-bit ABI to interoperate with 64-bit code. The calling convention (which is described by the ABI) defines how data structure, pointers, and values are passed in parameters of each function and accessed through the machine code.

Thinking is performed in the simulator using two strategies. For APIs that do not interoperate with complex data structures provided by the client (but deal with simple input and output values), the Turbo thunks (small conversion routines implemented in the simulator) take care of the conversion and directly invoke the native 64-bit API. Other complex APIs need the *Wow64SystemServiceEx* routine's assistance, which extracts the correct WoW64 system call table number from the system call index and invokes the correct WoW64 system call function. WoW64 system calls are implemented in the WoW64 core library and in *Wow64win.dll* and have the same name as the native system calls but with the *wh-* prefix. (So, for example, the *NtCreateFile* WoW64 API is called *whNtCreateFile*.)

After the conversion has been correctly performed, the simulator issues the corresponding native 64-bit system call. When the native system call returns, WoW64 converts (or thunks) any output parameters if necessary, from 64-bit to 32-bit formats, and restarts the simulation.

Exception dispatching

Similar to WoW64 system calls, exception dispatching forces the CPU simulation to exit. When an exception happens, the NT kernel determines whether it has been generated by a thread executing user-mode code. If so, the NT kernel builds an extended exception frame on the active stack and dispatches the exception by returning to the user-mode *KiUserExceptionDispatcher* function in the 64-bit Ntdll (for more information about exceptions, refer to the “Exception dispatching” section earlier in this chapter).

Note that a 64-bit exception frame (which includes the captured CPU context) is allocated in the 32-bit stack that was currently active when the exception was generated. Thus, it needs to be converted before being dispatched to the CPU simulator. This is exactly the role of the *Wow64PrepareForException* function (exported by the WoW64 core library), which allocates space on the native 64-bit stack and copies the native exception frame from the 32-bit stack in it. It then switches to the 64-bit stack and converts both the native exception and context records to their relative 32-bit counterpart, storing the result on the 32-bit stack (replacing the 64-bit exception frame). At this point, the WoW64 Core can restart the simulation from the 32-bit version of the *KiUserExceptionDispatcher* function, which dispatches the exception in the same way the native 32-bit Ntdll would.

32-bit user-mode APC delivery follows a similar implementation. A regular user-mode APC is delivered through the native Ntdll’s *KiUserApcDispatcher*. When the 64-bit kernel is about to dispatch a user-mode APC to a WoW64 process, it maps the 32-bit APC address to a higher range of 64-bit address space. The 64-bit Ntdll then invokes the *Wow64ApcRoutine* routine exported by the WoW64 core library, which captures the native APC and context record in user mode and maps it back in the 32-bit stack. It then prepares a 32-bit user-mode APC and context record and restarts the CPU simulation from the 32-bit version of the *KiUserApcDispatcher* function, which dispatches the APC the same way the native 32-bit Ntdll would.

ARM

ARM is a family of Reduced Instruction Set Computing (RISC) architectures originally designed by the ARM Holding company. The company, unlike Intel and AMD, designs the CPU’s architecture and licenses it to other companies, such as Qualcomm and Samsung, which produce the final CPUs. As a result, there have been multiple releases and versions of the ARM architecture, which have quickly evolved during the years, starting from very simple 32-bit CPUs, initially brought by the ARMv3 generation in the year 1993, up to the latest ARMv8. The, latest ARM64v8.2 CPUs natively support multiple execution modes (or states), most commonly AArch32, Thumb-2, and AArch64:

- AArch32 is the most classical execution mode, where the CPU executes 32-bit code only and transfers data to and from the main memory through a 32-bit bus using 32-bit registers.
- Thumb-2 is an execution state that is a subset of the AArch32 mode. The Thumb instruction set has been designed for improving code density in low-power embedded systems. In this mode, the CPU can execute a mix of 16-bit and 32-bit instructions, while still accessing 32-bit registers and memory.
- AArch64 is the modern execution mode. The CPU in this execution state has access to 64-bit general purpose registers and can transfer data to and from the main memory through a 64-bit bus.

Windows 10 for ARM64 systems can operate in the AArch64 or Thumb-2 execution mode (AArch32 is generally not used). Thumb-2 was especially used in old Windows RT systems. The current state of an ARM64 processor is determined also by the current Exception level (EL), which defines different levels of privilege: ARM currently defines three exception levels and two security states. They are both discussed more in depth in Chapter 9 and in the *ARM Architecture Reference Manual*.

Memory models

In the “Hardware side-channel vulnerabilities” earlier in this chapter, we introduced the concept of a cache coherency protocol, which guarantees that the same data located in a CPU’s core cache is observed while accessed by multiple processors (MESI is one of the most famous cache coherency protocols). Like the cache coherency protocol, modern CPUs also should provide a memory *consistency* (or ordering) *model* for solving another problem that can arise in multiprocessor environments: memory reordering. Some architectures (ARM64 is an example) are indeed free to re-order memory accesses with the goal to make more efficient use of the memory subsystem and parallelize memory access instructions (achieving better performance while accessing the slower memory bus). This kind of architecture follows a weak memory model, unlike the AMD64 architecture, which follows a strong memory model, in which memory access instructions are generally executed in program order. Weak models allow the processor to be faster and access the memory in a more efficient way but bring a lot of synchronization issues when developing multiprocessor software. In contrast, a strong model is more intuitive and stable, but it has the big drawback of being slower.

CPUs that can do memory reordering (following the weak model) provide some machine instructions that act as *memory barriers*. A barrier prevents the processor from reordering memory accesses before and after the barrier, helping multiprocessors synchronization issues. Memory barriers are slow; thus, they are used only when strictly needed by critical multiprocessor code in Windows, especially in synchronization primitives (like spinlocks, mutexes, pushlocks, and so on).

As we describe in the next section, the ARM64 jitter always makes use of memory barriers while translating x86 code in a multiprocessor environment. Indeed, it can’t infer whether the code that will execute could be run by multiple threads in parallel at the same time (and thus have potential synchronization issues). X86 follows a strong memory model, so it does not have the reordering issue, a part of generic out-of-order execution as explained in the previous section).



Note Other than the CPU, memory reordering can also affect the compiler, which, during compilation time, can reorder (and possibly remove) memory references in the source code for efficiency and speed reasons. This kind of reordering is called *compiler reordering*, whereas the type described in the previous section is *processor reordering*.

ARM32 simulation on ARM64 platforms

The simulation of ARM32 applications under ARM64 is performed in a very similar way as for x86 under AMD64. As discussed in the previous section, an ARM64v8 CPU is capable of dynamic switching between the AArch64 and Thumb-2 execution state (so it can execute 32-bit instructions directly in hardware). However, unlike AMD64 systems, the CPU can't switch execution mode in user mode via a specific instruction, so the WoW64 layer needs to invoke the NT kernel to request the execution mode switch. To do this, the *BtCpuSimulate* function, exported by the ARM-on-ARM64 CPU simulator (Wowarmhw.dll), saves the nonvolatile AArch64 registers in the 64-bit stack, restores the 32-bit context stored in WoW64 CPU area, and finally emits a well-defined system call (which has an invalid syscall number, -1).

The NT kernel exception handler (which, on ARM64, is the same as the syscall handler), detects that the exception has been raised due to a system call, thus it checks the syscall number. In case the number is the special -1, the NT kernel knows that the request is due to an execution mode change coming from WoW64. In that case, it invokes the *KiEnter32BitMode* routine, which sets the new execution state for the lower EL (exception level) to AArch32, dismisses the exception, and returns to user mode.

The code starts the execution in AArch32 state. Like the x86 simulator for AMD64 systems, the execution controls return to the simulator only in case an exception is raised or a system call is invoked. Both exceptions and system calls are dispatched in an identical way as for the x86 simulator under AMD64.

X86 simulation on ARM64 platforms

The x86-on-ARM64 CPU simulator (Xtajit.dll) is different from other binary translators described in the previous sections, mostly because it cannot directly execute x86 instructions using the hardware. The ARM64 processor is simply not able to understand any x86 instruction. Thus, the x86-on-ARM simulator implements a full x86 emulator and a jitter, which can translate blocks of x86 opcodes in AArch64 code and execute the translated blocks directly.

When the simulator process initialization function (*BtCpuProcessInit*) is invoked for a new WoW64 process, it builds the jitter main registry key for the process by combining the HKLM\SOFTWARE\Microsoft\Wow64\x86\xtajit path with the name of the main process image. If the key exists, the simulator queries multiple configuration information from it (most common are the multiprocessor compatibility and JIT block threshold size. Note that the simulator also queries configuration settings from the application compatibility database.) The simulator then allocates and compiles the Syscall page, which, as the name implies, is used for emitting x86 syscalls (the page is then linked to Ntdll thanks to the *Wow64Transition* variable). At this point, the simulator determines whether the process can use the XTA cache.

The simulator uses two different caches for storing precompiled code blocks: The internal cache is allocated per-thread and contains code blocks generated by the simulator while compiling x86 code executed by the thread (those code blocks are called *jitted* blocks); the external XTA cache is managed by the XtaCache service and contains all the jitted blocks generated lazily for an x86 image by the XtaCache service. The per-image XTA cache is stored in an external cache file (more details provided later in this chapter.) The process initialization routine allocates also the Compile Hybrid Executable (CHPE) bitmap, which covers the entire 4-GB address space potentially used by a 32-bit process. The bitmap uses a single bit to indicate that a page of memory contains CHPE code (CHPE is described later in this chapter.)

The simulator thread initialization routine (*BtCpuThreadInit*) initializes the compiler and allocates the per-thread CPU state on the native stack, an important data structure that contains the per-thread compiler state, including the x86 thread context, the x86 code emitter state, the internal code cache, and the configuration of the emulated x86 CPU (segment registers, FPU state, emulated CPUIDs.)

Simulator's image load notification

Unlike any other binary translator, the x86-on-ARM64 CPU simulator must be informed any time a new image is mapped in the process address space, including for the CHPE Ntdll. This is achieved thanks to the WoW64 core, which intercepts when the *NtMapViewOfSection* native API is called from the 32-bit code and informs the Xtjit simulator through the exported *BTCpuNotifyMapViewOfSection* routine. It is important that the notification happen because the simulator needs to update the internal compiler data, such as

- The CHPE bitmap (which needs to be updated by setting bits to 1 when the target image contains CHPE code pages)
- The internal emulated CFG (Control Flow Guard) state
- The XTA cache state for the image

In particular, whenever a new x86 or CHPE image is loaded, the simulator determines whether it should use the XTA cache for the module (through registry and application compatibility shim.) In case the check succeeded, the simulator updates the global per-process XTA cache state by requesting to the XtaCache service the updated cache for the image. In case the XtaCache service is able to identify and open an updated cache file for the image, it returns a section object to the simulator, which can be used to speed up the execution of the image. (The section contains precompiled ARM64 code blocks.)

Compiled Hybrid Portable Executables (CHPE)

Jitting an x86 process in ARM64 environments is challenging because the compiler should keep enough performance to maintain the application responsiveness. One of the major issues is tied to the memory ordering differences between the two architectures. The x86 emulator does not know how the original x86 code has been designed, so it is obliged to aggressively use memory barriers between each memory access made by the x86 image. Executing memory barriers is a slow operation. On average, about 40% of many applications' time is spent running operating system code. This meant that not emulating OS libraries would have allowed a gain in a lot of overall applications' performance.

These are the motivations behind the design of Compiled Hybrid Portable Executables (CHPE). A CHPE binary is a special hybrid executable that contains both x86 and ARM64-compatible code, which has been generated with full awareness of the original source code (the compiler knew exactly where to use memory barriers). The ARM64-compatible machine code is called *hybrid* (or CHPE) code: it is still executed in AArch64 mode but is generated following the 32-bit ABI for a better interoperability with x86 code.

CHPE binaries are created as standard x86 executables (the machine ID is still 014C as for x86); the main difference is that they include hybrid code, described by a table in the Hybrid Image metadata (stored as part of the image load configuration directory). When a CHPE binary is loaded into the

WoW64 process's address space, the simulator updates the CHPE bitmap by setting a bit to 1 for each page containing hybrid code described by the Hybrid metadata. When the jitter compiles the x86 code block and detects that the code is trying to invoke a hybrid function, it directly executes it (using the 32-bit stack), without wasting any time in any compilation.

The jitted x86 code is executed following a custom ABI, which means that there is a nonstandard convention on how the ARM64 registers are used and how parameters are passed between functions. CHPE code does not follow the same register conventions as jitted code (although hybrid code still follows a 32-bit ABI). This means that directly invoking CHPE code from the jitted blocks built by the compiler is not directly possible. To overcome this problem, CHPE binaries also include three different kinds of thunk functions, which allow the interoperability of CHPE with x86 code:

- A **pop** thunk allows x86 code to invoke a hybrid function by converting incoming (or outgoing) arguments from the guest (x86) caller to the CHPE convention and by directly transferring execution to the hybrid code.
- A **push** thunk allows CHPE code to invoke an x86 routine by converting incoming (or outgoing) arguments from the hybrid code to the guest (x86) convention and by calling the emulator to resume execution on the x86 code.
- An **export** thunk is a compatibility thunk created for supporting applications that detour x86 functions exported from OS modules with the goal of modifying their functionality. Functions exported from CHPE modules still contain a little amount of x86 code (usually 8 bytes), which semantically does not provide any sort of functionality but allows detours to be inserted by the external application.

The x86-on-ARM simulator makes the best effort to always load CHPE system binaries instead of standard x86 ones, but this is not always possible. In case a CHPE binary does not exist, the simulator will load the standard x86 one from the SysWow64 folder. In this case, the OS module will be jitted entirely.

EXPERIMENT: Dumping the hybrid code address range table

The Microsoft Incremental linker (`link.exe`) tool included in the Windows SDK and WDK is able to show some information stored in the hybrid metadata of the Image load configuration directory of a CHPE image. More information about the tool and how to install it are available in Chapter 9.

In this experiment, you will dump the hybrid metadata of `kernelbase.dll`, a system library that also has been compiled with CHPE support. You also can try the experiment with other CHPE libraries. After having installed the SDK or WDK on a ARM64 machine, open the Visual Studio Developer Command Prompt (or start the `LaunchBuildEnv.cmd` script file in case you are using the EWDK's Iso image.) Move to the CHPE folder and dump the image load configuration directory of the `kernelbase.dll` file through the following commands:

```
cd c:\Windows\SyChpe32
link /dump /loadconfig kernelbase.dll > kernelbase_loadconfig.txt
```

Note that in the example, the command output has been redirected to the `kernelbase_load-config.txt` text file because it was too large to be easily displayed in the console. Open the text file with Notepad and scroll down until you reach the following text:

Section contains the following hybrid metadata:

```
4 Version
102D900C Address of WowA64 exception handler function pointer
102D9000 Address of WowA64 dispatch call function pointer
102D9004 Address of WowA64 dispatch indirect call function pointer
102D9008 Address of WowA64 dispatch indirect call function pointer (with CFG check)
102D9010 Address of WowA64 dispatch return function pointer
102D9014 Address of WowA64 dispatch leaf return function pointer
102D9018 Address of WowA64 dispatch jump function pointer
102DE000 Address of WowA64 auxiliary import address table pointer
1011DAC8 Hybrid code address range table
4 Hybrid code address range count
```

Hybrid Code Address Range Table

```
Address Range
-----
x86 10001000 - 1000828F (00001000 - 0000828F)
arm64 1011E2E0 - 1029E09E (0011E2E0 - 0029E09E)
x86 102BA000 - 102BB865 (002BA000 - 002BB865)
arm64 102BC000 - 102C0097 (002BC000 - 002C0097)
```

The tool confirms that `kernelbase.dll` has four different ranges in the Hybrid code address range table: two sections contain x86 code (actually not used by the simulator), and two contain CHPE code (the tool shows the term “arm64” erroneously.)

The XTA cache

As introduced in the previous sections, the x86-on-ARM64 simulator, other than its internal per-thread cache, uses an external global cache called XTA cache, managed by the XtaCache protected service, which implements the lazy jitter. The service is an automatic start service, which, when started, opens (or creates) the `C:\Windows\XtaCache` folder and protects it through a proper ACL (only the XtaCache service and members of the Administrators group have access to the folder). The service starts its own ALPC server through the `{BEC19D6F-D7B2-41A8-860C-8787BB964F2D}` connection port. It then allocates the ALPC and lazy jit worker threads before exiting.

The ALPC worker thread is responsible in dispatching all the incoming requests to the ALPC server. In particular, when the simulator (the client), running in the context of a WoW64 process, connects to the XtaCache service, a new data structure tracking the x86 process is created and stored in an internal list, together with a 128 KB memory mapped section, which is shared between the client and XtaCache (the memory backing the section is internally called Trace buffer). The section is used by the simulator to send hints about the x86 code that has been jitted to execute the application and was not present in any cache, together with the module ID to which they belong. The information stored in the section is

processed every 1 second by the XTA cache or in case the buffer becomes full. Based on the number of valid entries in the list, the XtaCache can decide to directly start the lazy jitter.

When a new image is mapped into an x86 process, the WoW64 layer informs the simulator, which sends a message to the XtaCache looking for an already-existing XTA cache file. To find the cache file, the XtaCache service should first open the executable image, map it, and calculate its hashes. Two hashes are generated based on the executable image path and its internal binary data. The hashes are important because they avoid the execution of jitted blocks compiled for an old stale version of the executable image. The XTA cache file name is then generated using the following name scheme: *<module name>.<module header hash>.<module path hash>.<multi/uniproc>.<cache file version>.jc*. The cache file contains all the precompiled code blocks, which can be directly executed by the simulator. Thus, in case a valid cache file exists, the XtaCache creates a file-mapped section and injects it into the client WoW64 process.

The lazy jitter is the engine of the XtaCache. When the service decides to invoke it, a new version of the cache file representing the jitted x86 module is created and initialized. The lazy jitter then starts the lazy compilation by invoking the XTA offline compiler (xtac.exe). The compiler is started in a protected low-privileged environment (AppContainer process), which runs in low-priority mode. The only job of the compiler is to compile the x86 code executed by the simulator. The new code blocks are added to the ones located in the old version of the cache file (if one exists) and stored in a new version of the cache file.

EXPERIMENT: Witnessing the XTA cache

Newer versions of Process Monitor can run natively on ARM64 environments. You can use Process Monitor to observe how an XTA cache file is generated and used for an x86 process. In this experiment, you need an ARM64 system running at least Windows 10 May 2019 update (1903). Initially, you need to be sure that the x86 application used for the experiment has never before been executed by the system. In this example, we will install an old x86 version of MPC-HC media player, which can be downloaded from <https://sourceforge.net/projects/mpc-hc/files/latest/download>. Any x86 application is well suited for this experiment though.

Install MPC-HC (or your preferred x86 application), but, before running it, open Process Monitor and add a filter on the XtaCache service's process name (XtaCache.exe, as the service runs in its own process; it is not shared.) The filter should be configured as in the following figure:

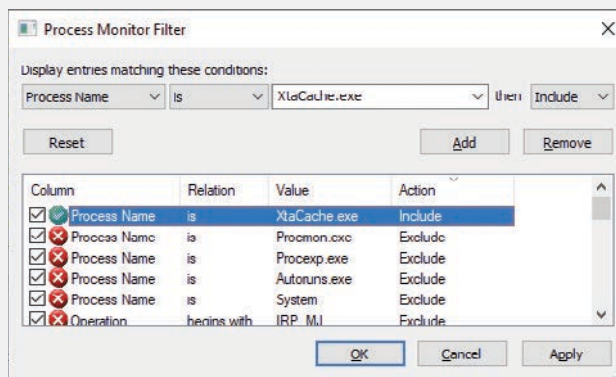

If not already done, start the events capturing by selecting Capture Events from the File menu. Then launch MPC-HC and try to play some video. Exit MPC-HC and stop the event capturing in Process Monitor. The number of events displayed by Process Monitor are significant. You can filter them by removing the registry activity by clicking the corresponding icon on the toolbar (in this experiment, you are not interested in the registry).

If you scroll the event list, you will find that the XtaCache service first tried to open the MPC-HC cache file, but it failed because the file didn't exist. This meant that the simulator started to compile the x86 image on its own and periodically sent information to the XtaCache. Later, the lazy jitter would have been invoked by a worker thread in the XtaCache. The latter created a new version of the Xta cache file and invoked the Xtac compiler, mapping the cache file section to both itself and Xtac:

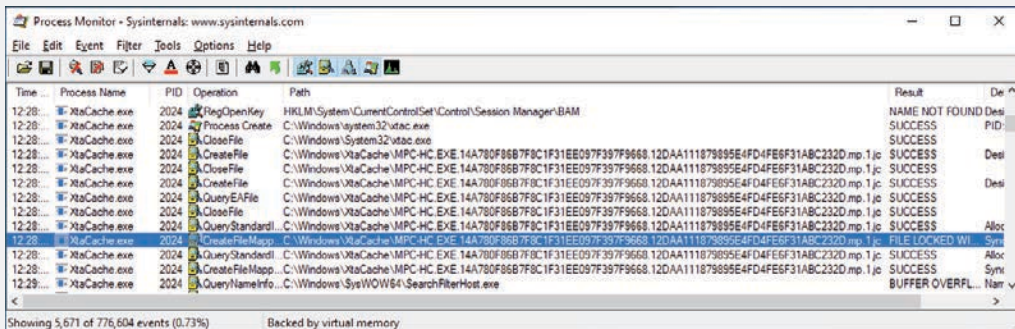

If you restart the experiment, you would see different events in Process Monitor: The cache file will be immediately mapped into the MPC-HC WoW64 process. In that way, the emulator can execute it directly. As a result, the execution time should be faster. You can also try to delete the generated XTA cache file. The XtaCache service automatically regenerates it after you launch the MPC-HC x86 application again.

However, remember that the %SystemRoot%\XtaCache folder is protected through a well-defined ACL owned by the XtaCache service itself. To access it, you should open an administrative command prompt window and insert the following commands:

```
takeown /f c:\windows\XtaCache
icacls c:\windows\XtaCache /grant Administrators:F
```

Jitting and execution

To start the guest process, the x86-on-ARM64 CPU simulator has no other chances than interpreting or jitting the x86 code. Interpreting the guest code means translating and executing one machine instruction at time, which is a slow process, so the emulator supports only the jitting strategy: it dynamically compiles x86 code to ARM64 and stores the result in a guest “code block” until certain conditions happen:

- An illegal opcode or a data or instruction breakpoint have been detected.
- A branch instruction targeting an already-visited block has been encountered.
- The block is bigger than a predetermined limit (512 bytes).

The simulation engine works by first checking in the local and XTA cache whether a code block (indexed by its RVA) already exists. If the block exists in the cache, the simulator directly executes it using a *dispatcher* routine, which builds the ARM64 context (containing the host registers values) and stores it in the 64-bit stack, switches to the 32-bit stack, and prepares it for the guest x86 thread state. Furthermore, it also prepares the ARM64 registers to run the jitted x86 code (storing the x86 context in them). Note that a well-defined non-standard calling convention exists: the dispatcher is similar to a pop thunk used for transferring the execution from a CHPE to an x86 context.

When the execution of the code block ends, the dispatcher does the opposite: It saves the new x86 context in the 32-bit stack, switches to the 64-bit stack, and restores the old ARM64 context containing the state of the simulator. When the dispatcher exits, the simulator knows the exact x86 virtual address where the execution was interrupted. It can then restart the emulation starting from that new memory address. Similar to cached entries, the simulator checks whether the target address points to a memory page containing CHPE code (it knows this information thanks to the global CHPE bitmap). If that is the case, the simulator resolves the pop thunk for the target function, adds its address to the thread’s local cache, and directly executes it.

In case one of the two described conditions verifies, the simulator can have performances similar to executing native images. Otherwise, it needs to invoke the compiler for building the native translated code block. The compilation process is split into three phases:

1. The **parsing** stage builds instructions descriptors for each opcode that needs to be added in the code block.
2. The **optimization** stage optimizes the instruction flow.
3. Finally, the **code generation** phase writes the final ARM64 machine code in the new code block.

The generated code block is then added to the per-thread local cache. Note that the simulator cannot add it in the XTA cache, mainly for security and performance reasons. Otherwise, an attacker would be allowed to pollute the cache of a higher-privileged process (as a result, the malicious code could have potentially been executed in the context of the higher-privileged process.) Furthermore, the simulator does not have enough CPU time to generate highly optimized code (even though there is an optimization stage) while maintaining the application’s responsiveness.

However, information about the compiled x86 blocks, together with the ID of the binary hosting the x86 code, are inserted into the list mapped by the shared Trace buffer. The lazy jitter of the XTA cache knows that it needs to compile the x86 code jitted by the simulator thanks to the Trace buffer. As a result, it generates optimized code blocks and adds them in the XTA cache file for the module, which will be directly executed by the simulator. Only the first execution of the x86 process is generally slower than the others.

System calls and exception dispatching

Under the x86-on-ARM64 CPU simulator, when an x86 thread performs a system call, it invokes the code located in the syscall page allocated by the simulator, which raises the exception 0x2E. Each x86 exception forces the code block to exit. The dispatcher, while exiting from the code block, dispatches the exception through an internal function that ends up in invoking the standard WoW64 exception handler or system call dispatcher (depending on the exception vector number.) Those have been already discussed in the previous X86 simulation on AMD64 platforms section of this chapter.

EXPERIMENT: Debugging WoW64 in ARM64 environments

Newer releases of WinDbg (the Windows Debugger) are able to debug machine code run under any simulator. This means that in ARM64 systems, you will be able to debug native ARM64, ARM Thumb-2, and x86 applications, whereas in AMD64 systems, you can debug only 32- and 64-bit x86 programs. The debugger is also able to easily switch between the native 64-bit and 32-bit stacks, which allows the user to debug both native (including the WoW64 layer and the emulator) and guest code (furthermore, the debugger also supports CHPE.)

In this experiment, you will open an x86 application using an ARM64 machine and switch between three execution modes: ARM64, ARM Thumb-2, and x86. For this experiment, you need to install a recent version of the Debugging tools, which you can find in the WDK or SDK. After installing one of the kits, open the ARM64 version of Windbg (available from the Start menu.)

Before starting the debug session, you should disable the exceptions that the XtaJit emulator generates, like Data Misaligned and in-page I/O errors (these exceptions are already handled by the emulator itself). From the **Debug** menu, click **Event Filters**. From the list, select the **Data Misaligned** event and check the **Ignore** option box from the **Execution** group. Repeat the same for the **In-page I/O** error. At the end, your configuration should look similar to the one in following figure:

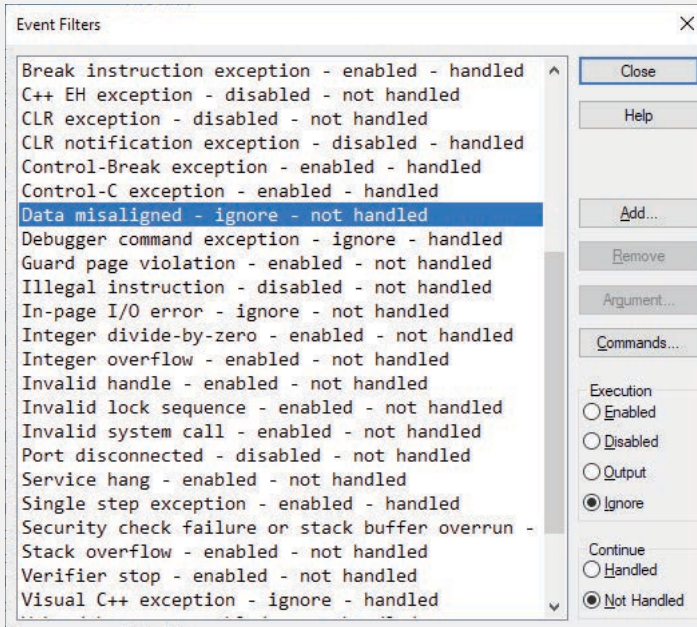

Click **Close**, and then from the main debugger interface, select **Open Executable** from the **File** menu. Choose one of the 32-bit x86 executables located in %SystemRoot%\SysWOW64 folder. (In this example, we are using notepad.exe, but any x86 application works.) Also open the disassembly window by selecting it through the View menu. If your symbols are configured correctly (refer to the <https://docs.microsoft.com/en-us/windows-hardware/drivers/debugger/symbol-path> webpage for instructions on how to configure symbols), you should see the first native Ntdll breakpoint, which can be confirmed by displaying the stack with the **k** command:

```
0:000> k
# Child-SP          RetAddr           Call Site
00 00000000`001eec70 00007ffb`bd47de00 ntdll!LdrpDoDebuggerBreak+0x2c
01 00000000`001eec90 00007ffb`bd47133c ntdll!LdrpInitializeProcess+0x1da8
02 00000000`001ef580 00007ffb`bd428180 ntdll!_LdrpInitialize+0x491ac
03 00000000`001ef660 00007ffb`bd428134 ntdll!LdrpInitialize+0x38
04 00000000`001ef680 00000000`00000000 ntdll!LdrInitializeThunk+0x14
```

The simulator is still not loaded at this time: The native and CHPE Ntdll have been mapped into the target binary by the NT kernel, while the WoW64 core binaries have been loaded by the native Ntdll just before the breakpoint via the *LdrpLoadWow64* function. You can check that by enumerating the currently loaded modules (via the **lm** command) and by moving to the next frame in the stack via the **.f+** command. In the disassembly window, you should see the invocation of the *LdrpLoadWow64* routine:

```
00007ffb`bd47dde4 97fed31b b1          ntdll!LdrpLoadWow64 (00007ffb`bd432a50)
```

Now resume the execution with the **g** command (or **F5** key). You should see multiple modules being loaded in the process address space and another breakpoint raising, this time under the x86 context. If you again display the stack via the **k** command, you can notice that a new column is displayed. Furthermore, the debugger added the x86 word in its prompt:

```
0:000:x86> k
# Arch ChildEBP RetAddr
00 x86 00acf7b8 77006fb8 ntdll!_76ec0000!LdrpDoDebuggerBreak+0x2b
01 CHPE 00acf7c0 77006fb8 ntdll!_76ec0000!#LdrpDoDebuggerBreak$push_thunk+0x48
02 CHPE 00acf820 76f44054 ntdll!_76ec0000!#LdrpInitializeProcess+0x20ec
03 CHPE 00acfad0 76f43e9c ntdll!_76ec0000!#_LdrpInitialize+0x1a4
04 CHPE 00acfb60 76f43e34 ntdll!_76ec0000!#LdrpInitialize+0x3c
05 CHPE 00acfb80 76ffc3cc ntdll!_76ec0000!LdrInitializeThunk+0x14
```

If you compare the new stack to the old one, you will see that the stack addresses have drastically changed (because the process is now executing using the 32-bit stack). Note also that some functions have the # symbol preceding them: WinDbg uses that symbol to represent functions containing CHPE code. At this point, you can step into and over x86 code, as in regular x86 operating systems. The simulator takes care of the emulation and hides all the details. To observe how the simulator is running, you should move to the 64-bit context through the `.effmach` command. The command accepts different parameters: x86 for the 32-bit x86 context; arm64 or amd64 for the native 64-bit context (depending on the target platform); arm for the 32-bit ARM Thumb2 context; CHPE for the 32-bit CHPE context. Switching to the 64-bit stack in this case is achieved via the arm64 parameter:

```
0:000:x86> .effmach arm64
Effective machine: ARM 64-bit (AArch64) (arm64)
0:000> k
# Child-SP RetAddr Call Site
00 00000000`00a8df30 00007ffb`bd3572a8 wow64!Wow64pNotifyDebugger+0x18f54
01 00000000`00a8df60 00007ffb`bd3724a4 wow64!Wow64pDispatchException+0x108
02 00000000`00a8e2e0 00000000`76e1e9dc wow64!Wow64RaiseException+0x84
03 00000000`00a8e400 00000000`76e0ebd8 xtajit!BTCpuSuspendLocalThread+0x24c
04 00000000`00a8e4c0 00000000`76de04c8 xtajit!BTCpuResetFloatingPoint+0x4828
05 00000000`00a8e530 00000000`76dd4bf8 xtajit!BTCpuUseChpeFile+0x9088
06 00000000`00a8e640 00007ffb`bd3552c4 xtajit!BTCpuSimulate+0x98
07 00000000`00a8e6b0 00007ffb`bd353788 wow64!RunCpuSimulation+0x14
08 00000000`00a8e6c0 00007ffb`bd47de38 wow64!Wow64LdrpInitialize+0x138
09 00000000`00a8e980 00007ffb`bd47133c ntdll!LdrpInitializeProcess+0x1de0
0a 00000000`00a8f270 00007ffb`bd428180 ntdll!_LdrpInitialize+0x491ac
0b 00000000`00a8f350 00007ffb`bd428134 ntdll!LdrpInitialize+0x38
0c 00000000`00a8f370 00000000`00000000 ntdll!LdrInitializeThunk+0x14
```

From the two stacks, you can see that the emulator was executing CHPE code, and then a push thunk has been invoked to restart the simulation to the `LdrpDoDebuggerBreak` x86 function, which caused an exception (managed through the native `Wow64RaiseException`) notified to the debugger via the `Wow64pNotifyDebugger` routine. With Windbg and the `.effmach` command, you can effectively debug multiple contexts: native, CHPE, and x86 code. Using the `g @$entry` command, you can move to the x86 entry point of Notepad and continue the debug session of x86 code or the emulator itself. You can restart this experiment also in different environments, debugging an app located in SysArm32, for example.

Object Manager

As mentioned in Chapter 2 of Part 1, “System architecture,” Windows implements an object model to provide consistent and secure access to the various internal services implemented in the executive. This section describes the Windows *Object Manager*, the executive component responsible for creating, deleting, protecting, and tracking objects. The Object Manager centralizes resource control operations that otherwise would be scattered throughout the operating system. It was designed to meet the goals listed after the experiment.

EXPERIMENT: Exploring the Object Manager

Throughout this section, you’ll find experiments that show you how to peer into the Object Manager database. These experiments use the following tools, which you should become familiar with if you aren’t already:

- WinObj (available from Sysinternals) displays the internal Object Manager’s namespace and information about objects (such as the reference count, the number of open handles, security descriptors, and so forth). WinObjEx64, available on GitHub, is a similar tool with more advanced functionality and is open source but not endorsed or signed by Microsoft.
- Process Explorer and Handle from Sysinternals, as well as Resource Monitor (introduced in Chapter 1 of Part 1) display the open handles for a process. Process Hacker is another tool that shows open handles and can show additional details for certain kinds of objects.
- The kernel debugger *!handle* extension displays the open handles for a process, as does the *!o.Handles* data model object underneath a Process such as @\$*curprocess*.

WinObj and WinObjEx64 provide a way to traverse the namespace that the Object Manager maintains. (As we’ll explain later, not all objects have names.) Run either of them and examine the layout, as shown in the figure.

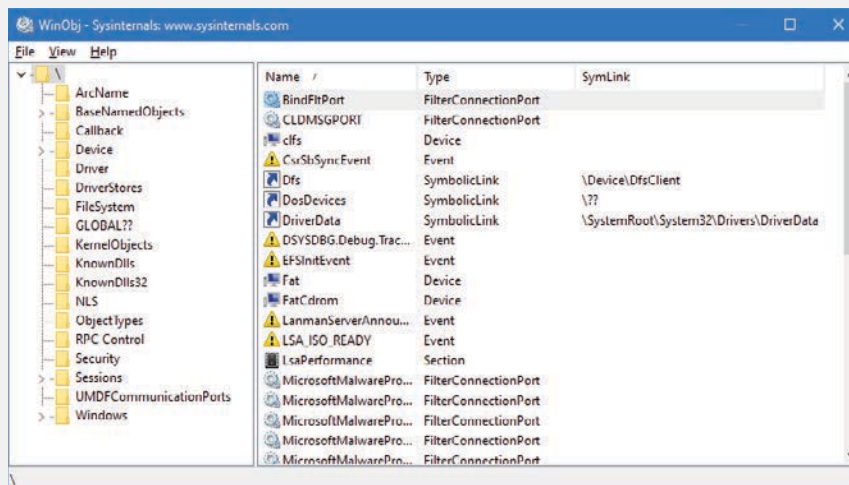

The Windows *Openfiles/query* command, which lists local and remote files currently opened in the system, requires that a Windows global flag called *maintain objects list* be enabled. (See the “Windows global flags” section later in Chapter 10 for more details about global flags.) If you type **Openfiles/Local**, it tells you whether the flag is enabled. You can enable it with the **Openfiles/Local ON** command, but you still need to reboot the system for the setting to take effect. Process Explorer, Handle, and Resource Monitor do not require object tracking to be turned on because they query all system handles and create a per-process object list. Process Hacker queries per-process handles using a mode-recent Windows API and also does not require the flag.

The Object Manager was designed to meet the following goals:

- Provide a common, uniform mechanism for using system resources.
- Isolate object protection to one location in the operating system to ensure uniform and consistent object access policy.
- Provide a mechanism to charge processes for their use of objects so that limits can be placed on the usage of system resources.
- Establish an object-naming scheme that can readily incorporate existing objects, such as the devices, files, and directories of a file system or other independent collections of objects.
- Support the requirements of various operating system environments, such as the ability of a process to inherit resources from a parent process (needed by Windows and Subsystem for UNIX Applications) and the ability to create case-sensitive file names (needed by Subsystem for UNIX Applications). Although Subsystem for UNIX Applications no longer exists, these facilities were also useful for the later development of the Windows Subsystem for Linux.
- Establish uniform rules for object retention (that is, for keeping an object available until all processes have finished using it).
- Provide the ability to isolate objects for a specific session to allow for both local and global objects in the namespace.
- Allow redirection of object names and paths through symbolic links and allow object owners, such as the file system, to implement their own type of redirection mechanisms (such as NTFS junction points). Combined, these redirection mechanisms compose what is called *reparsing*.

Internally, Windows has three primary types of objects: *executive objects*, *kernel objects*, and *GDI/User objects*. Executive objects are objects implemented by various components of the executive (such as the process manager, memory manager, I/O subsystem, and so on). Kernel objects are a more primitive set of objects implemented by the Windows kernel. These objects are not visible to user-mode code but are created and used only within the executive. Kernel objects provide fundamental capabilities, such as synchronization, on which executive objects are built. Thus, many executive objects contain (encapsulate) one or more kernel objects, as shown in Figure 8-30.



Note The vast majority of GDI/User objects, on the other hand, belong to the Windows subsystem (Win32k.sys) and do not interact with the kernel. For this reason, they are outside the scope of this book, but you can get more information on them from the Windows SDK. Two exceptions are the Desktop and Windows Station User objects, which are wrapped in executive objects, as well as the majority of DirectX objects (Shaders, Surfaces, Compositions), which are also wrapped as executive objects.

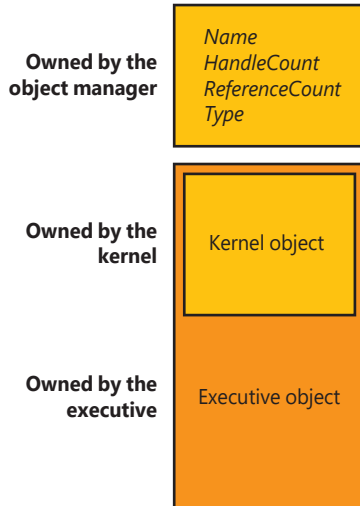

FIGURE 8-30 Executive objects that contain kernel objects.

Details about the structure of kernel objects and how they are used to implement synchronization are given later in this chapter. The remainder of this section focuses on how the Object Manager works and on the structure of executive objects, handles, and handle tables. We just briefly describe how objects are involved in implementing Windows security access checking; Chapter 7 of Part 1 thoroughly covers that topic.

Executive objects

Each Windows environment subsystem projects to its applications a different image of the operating system. The executive objects and object services are primitives that the environment subsystems use to construct their own versions of objects and other resources.

Executive objects are typically created either by an environment subsystem on behalf of a user application or by various components of the operating system as part of their normal operation. For example, to create a file, a Windows application calls the Windows *CreateFileW* function, implemented in the Windows subsystem DLL *Kernelbase.dll*. After some validation and initialization, *CreateFileW* in turn calls the native Windows service *NtCreateFile* to create an executive file object.

The set of objects an environment subsystem supplies to its applications might be larger or smaller than the set the executive provides. The Windows subsystem uses executive objects to export its own set of objects, many of which correspond directly to executive objects. For example, the Windows mutexes and semaphores are directly based on executive objects (which, in turn, are based on corresponding kernel objects). In addition, the Windows subsystem supplies named pipes and mailslots, resources that are based on executive file objects. When leveraging Windows Subsystem for Linux (WSL), its subsystem driver (Lxcore.sys) uses executive objects and services as the basis for presenting Linux-style processes, pipes, and other resources to its applications.

Table 8-15 lists the primary objects the executive provides and briefly describes what they represent. You can find further details on executive objects in the chapters that describe the related executive components (or in the case of executive objects directly exported to Windows, in the Windows API reference documentation). You can see the full list of object types by running Winobj with elevated rights and navigating to the ObjectTypes directory.



Note The executive implements a total of about 69 object types (depending on the Windows version). Some of these objects are for use only by the executive component that defines them and are not directly accessible by Windows APIs. Examples of these objects include *Driver*, *Callback*, and *Adapter*.

TABLE 8-15 Executive objects exposed to the Windows API

Object Type	Represents
Process	The virtual address space and control information necessary for the execution of a set of thread objects.
Thread	An executable entity within a process.
Job	A collection of processes manageable as a single entity through the job.
Section	A region of shared memory (known as a file-mapping object in Windows).
File	An instance of an opened file or an I/O device, such as a pipe or socket.
Token	The security profile (security ID, user rights, and so on) of a process or a thread.
Event, KeyedEvent	An object with a persistent state (signaled or not signaled) that can be used for synchronization or notification. The latter allows a global key to be used to reference the underlying synchronization primitive, avoiding memory usage, making it usable in low-memory conditions by avoiding an allocation.
Semaphore	A counter that provides a resource gate by allowing some maximum number of threads to access the resources protected by the semaphore.
Mutex	A synchronization mechanism used to serialize access to a resource.
Timer, IRTimer	A mechanism to notify a thread when a fixed period of time elapses. The latter objects, called Idle Resilient Timers, are used by UWP applications and certain services to create timers that are not affected by Connected Standby.
IoCompletion, IoCompletionReserve	A method for threads to enqueue and dequeue notifications of the completion of I/O operations (known as an I/O completion port in the Windows API). The latter allows preallocation of the port to combat low-memory situations.

Key	A mechanism to refer to data in the registry. Although keys appear in the Object Manager namespace, they are managed by the configuration manager, in a way like that in which file objects are managed by file system drivers. Zero or more key values are associated with a key object; key values contain data about the key.
Directory	A virtual directory in the Object Manager's namespace responsible for containing other objects or object directories.
SymbolicLink	A virtual name redirection link between an object in the namespace and another object, such as C:, which is a symbolic link to \Device\HarddiskVolumeN.
TpWorkerFactory	A collection of threads assigned to perform a specific set of tasks. The kernel can manage the number of work items that will be performed on the queue, how many threads should be responsible for the work, and dynamic creation and termination of worker threads, respecting certain limits the caller can set. Windows exposes the worker factory object through <i>thread pools</i> .
TmRm (Resource Manager), TmTx (Transaction), TmTm (Transaction Manager), TmEn (Enlistment)	Objects used by the Kernel Transaction Manager (KTM) for various <i>transactions</i> and/or <i>enlistments</i> as part of a <i>resource manager</i> or <i>transaction manager</i> . Objects can be created through the <i>CreateTransactionManager</i> , <i>CreateResourceManager</i> , <i>CreateTransaction</i> , and <i>CreateEnlistment</i> APIs.
RegistryTransaction	Object used by the low-level lightweight registry transaction API that does not leverage the full KTM capabilities but still allows simple transactional access to registry keys.
WindowStation	An object that contains a clipboard, a set of global atoms, and a group of Desktop objects.
Desktop	An object contained within a window station. A desktop has a logical display surface and contains windows, menus, and hooks.
PowerRequest	An object associated with a thread that executes, among other things, a call to <i>SetThreadExecutionState</i> to request a given power change, such as blocking sleeps (due to a movie being played, for example).
EtwConsumer	Represents a connected ETW real-time consumer that has registered with the <i>StartTrace</i> API (and can call <i>ProcessTrace</i> to receive the events on the object queue).
CoverageSampler	Created by ETW when enabling code coverage tracing on a given ETW session.
EtwRegistration	Represents the registration object associated with a user-mode (or kernel-mode) ETW provider that registered with the <i>EventRegister</i> API.
ActivationObject	Represents the object that tracks foreground state for window handles that are managed by the Raw Input Manager in Win32k.sys.
ActivityReference	Tracks processes managed by the Process Lifetime Manager (PLM) and that should be kept awake during Connected Standby scenarios.
ALPC Port	Used mainly by the Remote Procedure Call (RPC) library to provide Local RPC (LRPC) capabilities when using the ncalrpc transport. Also available to internal services as a generic IPC mechanism between processes and/or the kernel.
Composition, DxgkCompositionObject, DxgkCurrentDxgProcessObject, DxgkDisplayManagerObject, DxgkSharedBundleObject, DxgkSharedKeyedMutexObject, DxgkShardedProtectedSessionObject, DgkxSharedResource, DxgkSwapChainObject, DxgkSharedSyncObject	Used by DirectX 12 APIs in user-space as part of advanced shader and GPGPU capabilities, these executive objects wrap the underlying DirectX handle(s).

CoreMessaging	Represents a CoreMessaging IPC object that wraps an ALPC port with its own customized namespace and capabilities; used primarily by the modern Input Manager but also exposed to any MinUser component on WCOS systems.
EnergyTracker	Exposed to the User Mode Power (UMPO) service to allow tracking and aggregation of energy usage across a variety of hardware and associating it on a per-application basis.
FilterCommunicationPort, FilterConnectionPort	Underlying objects backing the IRP-based interface exposed by the Filter Manager API, which allows communication between user-mode services and applications, and the mini-filters that are managed by Filter Manager, such as when using <i>FilterSendMessage</i> .
Partition	Enables the memory manager, cache manager, and executive to treat a region of physical memory as unique from a management perspective vis-à-vis the rest of system RAM, giving it its own instance of management threads, capabilities, paging, caching, etc. Used by Game Mode and Hyper-V, among others, to better distinguish the system from the underlying workloads.
Profile	Used by the profiling API that allows capturing time-based buckets of execution that track anything from the Instruction Pointer (IP) all the way to low-level processor caching information stored in the PMU counters.
RawInputManager	Represents the object that is bound to an HID device such as a mouse, keyboard, or tablet and allows reading and managing the window manager input that is being received by it. Used by modern UI management code such as when Core Messaging is involved.
Session	Object that represents the memory manager's view of an interactive user session, as well as tracks the I/O manager's notifications around connect/disconnect/log-off/logon for third-party driver usage.
Terminal	Only enabled if the <i>terminal thermal manager</i> (TTM) is enabled, this represents a user terminal on a device, which is managed by the user mode power manager (UMPO).
TerminalEventQueue	Only enabled on TTM systems, like the preceding object type, this represents events being delivered to a terminal on a device, which UMPO communicates with the kernel's power manager about.
UserApcReserve	Similar to IoCompletionReserve in that it allows precreating a data structure to be reused during low-memory conditions, this object encapsulates an APC Kernel Object (KAPC) as an executive object.
WaitCompletionPacket	Used by the new asynchronous wait capabilities that were introduced in the user-mode Thread Pool API, this object wraps the completion of a dispatcher wait as an I/O packet that can be delivered to an I/O completion port.
WmiGuid	Used by the Windows Management Instrumentation (WMI) APIs when opening WMI Data Blocks by GUID, either from user mode or kernel mode, such as with <i>IoWMIOpenBlock</i> .



Note Because Windows NT was originally supposed to support the OS/2 operating system, the mutex had to be compatible with the existing design of OS/2 mutual-exclusion objects, a design that required that a thread be able to abandon the object, leaving it inaccessible. Because this behavior was considered unusual for such an object, another kernel object—the mutant—was created. Eventually, OS/2 support was dropped, and the object became used by the Windows 32 subsystem under the name mutex (but it is still called mutant internally).

Object structure

As shown in Figure 8-31, each object has an object header, an object body, and potentially, an object footer. The Object Manager controls the object headers and footer, whereas the owning executive components control the object bodies of the object types they create. Each object header also contains an index to a special object, called the *type object*, that contains information common to each instance of the object. Additionally, up to eight optional subheaders exist: The name information header, the quota information header, the process information header, the handle information header, the audit information header, the padding information header, the extended information header, and the creator information header. If the extended information header is present, this means that the object has a footer, and the header will contain a pointer to it.

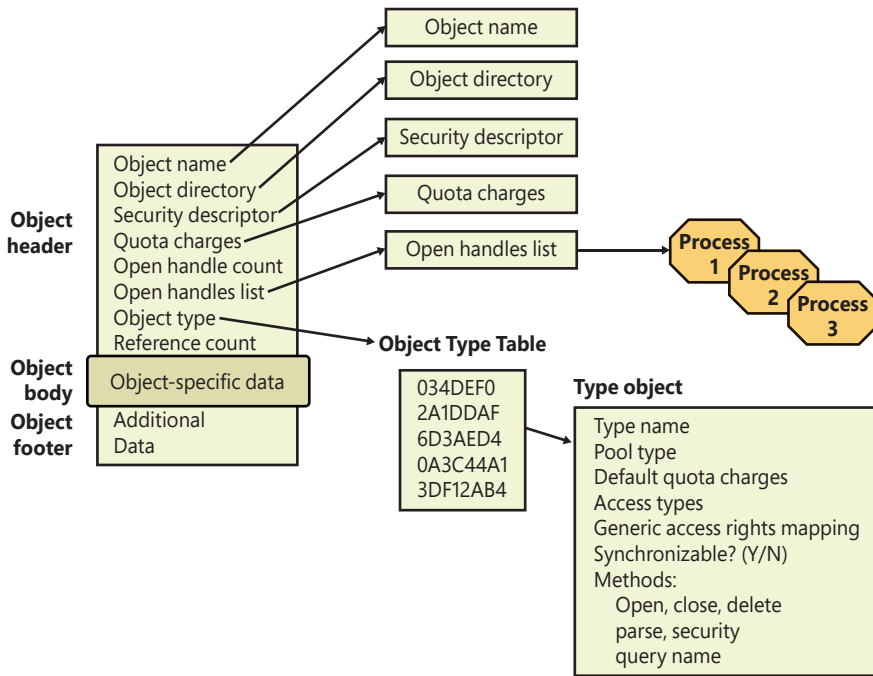

FIGURE 8-31 Structure of an object.

Object headers and bodies

The Object Manager uses the data stored in an object's header to manage objects without regard to their type. Table 8-16 briefly describes the object header fields, and Table 8-17 describes the fields found in the optional object subheaders.

In addition to the object header, which contains information that applies to any kind of object, the subheaders contain optional information regarding specific aspects of the object. Note that these structures are located at a variable offset from the start of the object header, the value of which depends on the number of subheaders associated with the main object header (except, as mentioned

earlier, for creator information). For each subheader that is present, the *InfoMask* field is updated to reflect its existence. When the Object Manager checks for a given subheader, it checks whether the corresponding bit is set in the *InfoMask* and then uses the remaining bits to select the correct offset into the global *ObpInfoMaskToOffset* table, where it finds the offset of the subheader from the start of the object header.

TABLE 8-16 Object header fields

Field	Purpose
Handle count	Maintains a count of the number of currently opened handles to the object.
Pointer count	Maintains a count of the number of references to the object (including one reference for each handle), and the number of <i>usage</i> references for each handle (up to 32 for 32-bit systems, and 32,768 for 64-bit systems). Kernel-mode components can reference an object <i>by pointer</i> without using a handle.
Security descriptor	Determines who can use the object and what they can do with it. Note that unnamed objects, by definition, cannot have security.
Object type index	Contains the index to a type object that contains attributes common to objects of this type. The table that stores all the type objects is <i>ObTypeIndexTable</i> . Due to a security mitigation, this index is XOR'ed with a dynamically generated sentinel value stored in <i>ObHeaderCookie</i> and the bottom 8 bits of the address of the object header itself.
Info mask	Bitmask describing which of the optional subheader structures described in Table 8-17 are present, except for the creator information subheader, which, if present, always precedes the object. The bitmask is converted to a negative offset by using the <i>ObpInfoMaskToOffset</i> table, with each subheader being associated with a 1-byte index that places it relative to the other subheaders present.
Flags	Characteristics and object attributes for the object. See Table 8-20 for a list of all the object flags.
Lock	Per-object lock used when modifying fields belonging to this object header or any of its subheaders.
Trace Flags	Additional flags specifically related to tracing and debugging facilities, also described in Table 8-20.
Object Create Info	Ephemeral information about the creation of the object that is stored until the object is fully inserted into the namespace. This field converts into a pointer to the Quota Block after creation.

These offsets exist for all possible combinations of subheader presence, but because the subheaders, if present, are always allocated in a fixed, constant order, a given header will have only as many possible locations as the maximum number of subheaders that precede it. For example, because the name information subheader is always allocated first, it has only one possible offset. On the other hand, the handle information subheader (which is allocated third) has three possible locations because it might or might not have been allocated after the quota subheader, itself having possibly been allocated after the name information. Table 8-17 describes all the optional object subheaders and their locations. In the case of creator information, a value in the object header flags determines whether the subheader is present. (See Table 8-20 for information about these flags.)

TABLE 8-17 Optional object subheaders

Name	Purpose	Bit	Offset
Creator information	Links the object into a list for all the objects of the same type and records the process that created the object, along with a back trace.	0 (0x1)	<i>ObpInfoMaskToOffset</i> [0])
Name information	Contains the object name, responsible for making an object visible to other processes for sharing, and a pointer to the object directory, which provides the hierarchical structure in which the object names are stored.	1 (0x2)	<i>ObpInfoMaskToOffset</i> [InfoMask & 0x3]
Handle information	Contains a database of entries (or just a single entry) for a process that has an open handle to the object (along with a per-process handle count).	2 (0x4)	<i>ObpInfoMaskToOffset</i> [InfoMask & 0x7]
Quota information	Lists the resource charges levied against a process when it opens a handle to the object.	3 (0x8)	<i>ObpInfoMaskToOffset</i> [InfoMask & 0xF]
Process information	Contains a pointer to the owning process if this is an exclusive object. More information on exclusive objects follows later in the chapter.	4 (0x10)	<i>ObpInfoMaskToOffset</i> [InfoMask & 0x1F]
Audit information	Contains a pointer to the original security descriptor that was used when first creating the object. This is used for File Objects when auditing is enabled to guarantee consistency.	5 (0x20)	<i>ObpInfoMaskToOffset</i> [InfoMask & 0x3F]
Extended information	Stores the pointer to the object footer for objects that require one, such as File and Silo Context Objects.	6 (0x40)	<i>ObpInfoMaskToOffset</i> [InfoMask & 0x7F]
Padding information	Stores nothing—empty junk space—but is used to align the object body on a cache boundary, if this was requested.	7 (0x80)	<i>ObpInfoMaskToOffset</i> [InfoMask & 0xFF]

Each of these subheaders is optional and is present only under certain conditions, either during system boot or at object creation time. Table 8-18 describes each of these conditions.

TABLE 8-18 Conditions required for presence of object subheaders

Name	Condition
Creator information	The object type must have enabled the <i>maintain type list</i> flag. Driver objects have this flag set if the Driver Verifier is enabled. However, enabling the <i>maintain object type list</i> global flag (discussed earlier) enables this for all objects, and <i>Type</i> objects always have the flag set.
Name information	The object must have been created with a name.
Handle information	The object type must have enabled the <i>maintain handle count</i> flag. File objects, ALPC objects, WindowStation objects, and Desktop objects have this flag set in their object type structure.
Quota information	The object must not have been created by the initial (or idle) system process.
Process information	The object must have been created with the <i>exclusive object</i> flag. (See Table 8-20 for information about object flags.)
Audit Information	The object must be a File Object, and auditing must be enabled for file object events.
Extended information	The object must need a footer, either due to handle revocation information (used by File and Key objects) or to extended user context info (used by Silo Context objects).
Padding Information	The object type must have enabled the <i>cache aligned</i> flag. Process and thread objects have this flag set.

As indicated, if the extended information header is present, an object footer is allocated at the tail of the object body. Unlike object subheaders, the footer is a statically sized structure that is preallocated for all possible footer types. There are two such footers, described in Table 8-19.

TABLE 8-19 Conditions required for presence of object footer

Name	Condition
Handle Revocation Information	The object must be created with <i>ObCreateObjectEx</i> , passing in <i>AllowHandleRevocation</i> in the <i>OB_EXTENDED_CREATION_INFO</i> structure. File and Key objects are created this way.
Extended User Information	The object must be created with <i>ObCreateObjectEx</i> , passing in <i>AllowExtendedUserInfo</i> in the <i>OB_EXTENDED_CREATION_INFO</i> structure. Silo Context objects are created this way.

Finally, a number of attributes and/or flags determine the behavior of the object during creation time or during certain operations. These flags are received by the Object Manager whenever any new object is being created, in a structure called the *object attributes*. This structure defines the object name, the root object directory where it should be inserted, the security descriptor for the object, and the *object attribute flags*. Table 8-20 lists the various flags that can be associated with an object.



Note When an object is being created through an API in the Windows subsystem (such as *CreateEvent* or *CreateFile*), the caller does not specify any object attributes—the subsystem DLL performs the work behind the scenes. For this reason, all named objects created through Win32 go in the *BaseNamedObjects* directory, either the global or per-session instance, because this is the root object directory that *Kernelbase.dll* specifies as part of the object attributes structure. More information on *BaseNamedObjects* and how it relates to the per-session namespace follows later in this chapter.

TABLE 8-20 Object flags

Attributes Flag	Header Flag Bit	Purpose
<i>OBJ_INHERIT</i>	Saved in the handle table entry	Determines whether the handle to the object will be inherited by child processes and whether a process can use <i>DuplicateHandle</i> to make a copy.
<i>OBJ_PERMANENT</i>	PermanentObject	Defines object retention behavior related to reference counts, described later.
<i>OBJ_EXCLUSIVE</i>	ExclusiveObject	Specifies that the object can be used only by the process that created it.
<i>OBJ_CASE_INSENSITIVE</i>	Not stored, used at run time	Specifies that lookups for this object in the namespace should be case insensitive. It can be overridden by the <i>case insensitive</i> flag in the object type.
<i>OBJ_OPENIF</i>	Not stored, used at run time	Specifies that a create operation for this object name should result in an open, if the object exists, instead of a failure.
<i>OBJ_OPENLINK</i>	Not stored, used at run time	Specifies that the Object Manager should open a handle to the symbolic link, not the target.
<i>OBJ_KERNEL_HANDLE</i>	KernelObject	Specifies that the handle to this object should be a <i>kernel handle</i> (more on this later).

Attributes Flag	Header Flag Bit	Purpose
<i>OBJ_FORCE_ACCESS_CHECK</i>	Not stored, used at run time	Specifies that even if the object is being opened from kernel mode, full access checks should be performed.
<i>OBJ_KERNEL_EXCLUSIVE</i>	KernelOnlyAccess	Disables any user-mode process from opening a handle to the object; used to protect the <i>\Device\PhysicalMemory</i> and <i>\Win32kSessionGlobals</i> section objects.
<i>OBJ_IGNORE_IMPERSONATED_DEVICEMAP</i>	Not stored, used at run time	Indicates that when a token is being impersonated, the DOS Device Map of the source user should <i>not</i> be used, and the current impersonating process's DOS Device Map should be maintained for object lookup. This is a security mitigation for certain types of file-based redirection attacks.
<i>OBJ_DONT_REPARSE</i>	Not stored, used at run time	Disables any kind of reparsing situation (symbolic links, NTFS reparse points, registry key redirection), and returns <i>STATUS_REPARSE_POINT_ENCOUNTERED</i> if any such situation occurs. This is a security mitigation for certain types of path redirection attacks.
N/A	DefaultSecurityQuota	Specifies that the object's security descriptor is using the default 2 KB quota.
N/A	SingleHandleEntry	Specifies that the handle information subheader contains only a single entry and not a database.
N/A	NewObject	Specifies that the object has been created but not yet inserted into the object namespace.
N/A	DeletedInline	Specifies that the object is <i>not</i> being deleted through the <i>deferred deletion worker thread</i> but rather inline through a call to <i>ObDereferenceObject(Ex)</i> .

In addition to an object header, each object has an object body whose format and contents are unique to its object type; all objects of the same type share the same object body format. By creating an object type and supplying services for it, an executive component can control the manipulation of data in all object bodies of that type. Because the object header has a static and well-known size, the Object Manager can easily look up the object header for an object simply by subtracting the size of the header from the pointer of the object. As explained earlier, to access the subheaders, the Object Manager subtracts yet another well-known value from the pointer of the object header. For the footer, the extended information subheader is used to find the pointer to the object footer.

Because of the standardized object header, footer, and subheader structures, the Object Manager is able to provide a small set of generic services that can operate on the attributes stored in any object header and can be used on objects of any type (although some generic services don't make sense for certain objects). These generic services, some of which the Windows subsystem makes available to Windows applications, are listed in Table 8-21.

Although *all* of these services are not generally implemented by most object types, they typically implement at least create, open, and basic management services. For example, the I/O system implements a create file service for its file objects, and the process manager implements a create process service for its process objects.

However, some objects may not directly expose such services and could be internally created as the result of some user operation. For example, when opening a WMI Data Block from user mode, a WmiGuid object is created, but no handle is exposed to the application for any kind of close or query services. The key thing to understand, however, is that there is no single generic creation routine.

Such a routine would have been quite complicated because the set of parameters required to initialize a file object, for example, differs markedly from what is required to initialize a process object. Also, the Object Manager would have incurred additional processing overhead each time a thread called an object service to determine the type of object the handle referred to and to call the appropriate version of the service.

TABLE 8-21 Generic object services

Service	Purpose
Close	Closes a handle to an object, if allowed (more on this later).
Duplicate	Shares an object by duplicating a handle and giving it to another process (if allowed, as described later).
Inheritance	If a handle is marked as inheritable, and a child process is spawned with handle inheritance enabled, this behaves like duplication for those handles.
Make permanent/temporary	Changes the retention of an object (described later).
Query object	Gets information about an object's standard attributes and other details managed at the Object Manager level.
Query security	Gets an object's security descriptor.
Set security	Changes the protection on an object.
Wait for a single object	Associates a wait block with one object, which can then synchronize a thread's execution or be associated with an I/O completion port through a wait completion packet.
Signal an object and wait for another	Signals the object, performing wake semantics on the dispatcher object backing it, and then waits on a single object as per above. The wake/wait operation is done atomically from the scheduler's perspective..
Wait for multiple objects	Associates a wait block with one or more objects, up to a limit (64), which can then synchronize a thread's execution or be associated with an I/O completion port through a wait completion packet.

Type objects

Object headers contain data that is common to all objects but that can take on different values for each instance of an object. For example, each object has a unique name and can have a unique security descriptor. However, objects also contain some data that remains constant for all objects of a particular type. For example, you can select from a set of access rights specific to a type of object when you open a handle to objects of that type. The executive supplies terminate and suspend access (among others) for thread objects and read, write, append, and delete access (among others) for file objects. Another example of an object-type-specific attribute is synchronization, which is described shortly.

To conserve memory, the Object Manager stores these static, object-type-specific attributes once when creating a new object type. It uses an object of its own, a type object, to record this data. As Figure 8-32 illustrates, if the object-tracking debug flag (described in the "Windows global flags"

section later in this chapter) is set, a type object also links together all objects of the same type (in this case, the process type), allowing the Object Manager to find and enumerate them, if necessary. This functionality takes advantage of the creator information subheader discussed previously.

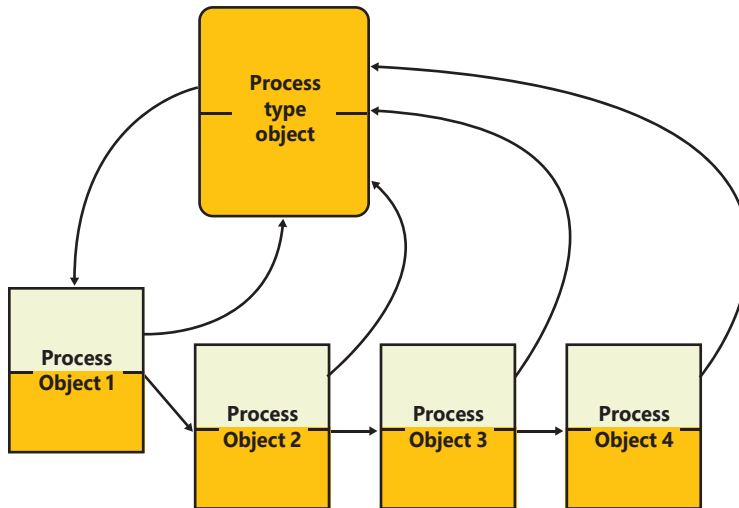

FIGURE 8-32 Process objects and the process type object.

EXPERIMENT: Viewing object headers and type objects

You can look at the process object type data structure in the kernel debugger by first identifying a process object with the **dx @\$cursession.Processes** debugger data model command:

```
1kd> dx -r0 &@$cursession.Processes[4].Kerne1Object
&@$cursession.Processes[4].Kerne1Object : 0xffff898f0327d300 [Type: _EPROCESS *]
```

Then execute the **!object** command with the process object address as the argument:

```
1kd> !object 0xffff898f0327d300
Object: ffff898f0327d300 Type: (ffff898f032954e0) Process
ObjectHeader: ffff898f0327d2d0 (new version)
HandleCount: 6 PointerCount: 215645
```

Notice that on 32-bit Windows, the object header starts 0x18 (24 decimal) bytes prior to the start of the object body, and on 64-bit Windows, it starts 0x30 (48 decimal) bytes prior—the size of the object header itself. You can view the object header with this command:

```
1kd> dx (nt!_OBJECT_HEADER*)0xffff898f0327d2d0
(nt!_OBJECT_HEADER*)0xffff898f0327d2d0 : 0xffff898f0327d2d0 [Type: _OBJECT_HEADER *]
[+0x000] PointerCount : 214943 [Type: __int64]
[+0x008] HandleCount : 6 [Type: __int64]
[+0x008] NextToFree : 0x6 [Type: void *]
[+0x010] Lock [Type: _EX_PUSH_LOCK]
[+0x018] TypeIndex : 0x93 [Type: unsigned char]
[+0x019] TraceFlags : 0x0 [Type: unsigned char]
[+0x019 ( 0: 0)] DbgRefTrace : 0x0 [Type: unsigned char]
```

```

[+0x019 ( 1: 1)] DbgTracePermanent : 0x0 [Type: unsigned char]
[+0x01a] InfoMask : 0x80 [Type: unsigned char]
[+0x01b] Flags : 0x2 [Type: unsigned char]
[+0x01b ( 0: 0)] NewObject : 0x0 [Type: unsigned char]
[+0x01b ( 1: 1)] KernelObject : 0x1 [Type: unsigned char]
[+0x01b ( 2: 2)] KernelOnlyAccess : 0x0 [Type: unsigned char]
[+0x01b ( 3: 3)] ExclusiveObject : 0x0 [Type: unsigned char]
[+0x01b ( 4: 4)] PermanentObject : 0x0 [Type: unsigned char]
[+0x01b ( 5: 5)] DefaultSecurityQuota : 0x0 [Type: unsigned char]
[+0x01b ( 6: 6)] SingleHandleEntry : 0x0 [Type: unsigned char]
[+0x01b ( 7: 7)] DeletedInline : 0x0 [Type: unsigned char]
[+0x01c] Reserved : 0xffff898f [Type: unsigned long]
[+0x020] ObjectCreateInfo : 0xfffff8047ee6d500 [Type: _OBJECT_CREATE_INFORMATION *]
[+0x020] QuotaBlockCharged : 0xfffff8047ee6d500 [Type: void *]
[+0x028] SecurityDescriptor : 0xffffc704ade03b6a [Type: void *]
[+0x030] Body [Type: _QUAD]
ObjectType : Process
UnderlyingObject [Type: _EPROCESS]

```

Now look at the object type data structure by copying the pointer that **!object** showed you earlier:

```

!kd> dx (nt!_OBJECT_TYPE*)0xfffff898f032954e0
(nt!_OBJECT_TYPE*)0xfffff898f032954e0 : 0xfffff898f032954e0 [Type: _OBJECT_TYPE *]
[+0x000] TypeList [Type: _LIST_ENTRY]
[+0x010] Name : "Process" [Type: _UNICODE_STRING]
[+0x020] DefaultObject : 0x0 [Type: void *]
[+0x028] Index : 0x7 [Type: unsigned char]
[+0x02c] TotalNumberOfObjects : 0x2e9 [Type: unsigned long]
[+0x030] TotalNumberOfHandles : 0x15a1 [Type: unsigned long]
[+0x034] HighWaterNumberOfObjects : 0x2f9 [Type: unsigned long]
[+0x038] HighWaterNumberOfHandles : 0x170d [Type: unsigned long]
[+0x040] TypeInfo [Type: _OBJECT_TYPE_INITIALIZER]
[+0x0b8] TypeLock [Type: _EX_PUSH_LOCK]
[+0x0c0] Key : 0x636f7250 [Type: unsigned long]
[+0x0c8] CallbackList [Type: _LIST_ENTRY]

```

The output shows that the object type structure includes the name of the object type, tracks the total number of active objects of that type, and tracks the peak number of handles and objects of that type. The *CallbackList* also keeps track of any Object Manager filtering callbacks that are associated with this object type. The *TypeInfo* field stores the data structure that keeps attributes, flags, and settings common to all objects of the object type as well as pointers to the object type's custom methods, which we'll describe shortly:

```

!kd> dx ((nt!_OBJECT_TYPE*)0xfffff898f032954e0)->TypeInfo
((nt!_OBJECT_TYPE*)0xfffff898f032954e0)->TypeInfo [Type: _OBJECT_TYPE_INITIALIZER]
[+0x000] Length : 0x78 [Type: unsigned short]
[+0x002] ObjectTypeFlags : 0xca [Type: unsigned short]
[+0x002 ( 0: 0)] CaseInsensitive : 0x0 [Type: unsigned char]
[+0x002 ( 1: 1)] UnnamedObjectsOnly : 0x1 [Type: unsigned char]
[+0x002 ( 2: 2)] UseDefaultObject : 0x0 [Type: unsigned char]
[+0x002 ( 3: 3)] SecurityRequired : 0x1 [Type: unsigned char]
[+0x002 ( 4: 4)] MaintainHandleCount : 0x0 [Type: unsigned char]
[+0x002 ( 5: 5)] MaintainTypeList : 0x0 [Type: unsigned char]

```

```

[+0x002 ( 6: 6)] SupportsObjectCallbacks : 0x1 [Type: unsigned char]
[+0x002 ( 7: 7)] CacheAligned           : 0x1 [Type: unsigned char]
[+0x003 ( 0: 0)] UseExtendedParameters : 0x0 [Type: unsigned char]
[+0x003 ( 7: 1)] Reserved                : 0x0 [Type: unsigned char]
[+0x004] ObjectTypeCode                 : 0x20 [Type: unsigned long]
[+0x008] InvalidAttributes               : 0xb0 [Type: unsigned long]
[+0x00c] GenericMapping                  [Type: _GENERIC_MAPPING]
[+0x01c] ValidAccessMask                 : 0x1fffff [Type: unsigned long]
[+0x020] RetainAccess                    : 0x101000 [Type: unsigned long]
[+0x024] PoolType                        : NonPagedPoolNx (512) [Type: _POOL_TYPE]
[+0x028] DefaultPagedPoolCharge          : 0x1000 [Type: unsigned long]
[+0x02c] DefaultNonPagedPoolCharge       : 0x8d8 [Type: unsigned long]
[+0x030] DumpProcedure                   : 0x0 [Type: void (__cdecl*)(void *,_OBJECT_DUMP_CONTROL *)]
[+0x038] OpenProcedure                   : 0xfffff8047f062f40 [Type: long (__cdecl*)(_OB_OPEN_REASON,char,_EPROCESS *,void *,unsigned long *,unsigned long)]
[+0x040] CloseProcedure                   : 0xfffff8047f087a90 [Type: void (__cdecl*)(_EPROCESS *,void *,unsigned __int64,unsigned __int64)]
[+0x048] DeleteProcedure                  : 0xfffff8047f02f030 [Type: void (__cdecl*)(void *)]
[+0x050] ParseProcedure                   : 0x0 [Type: long (__cdecl*)(void *,void *,_ACCESS_STATE *,char,unsigned long,_UNICODE_STRING *,_UNICODE_STRING *,void *,_SECURITY_QUALITY_OF_SERVICE *,void * *)]
[+0x050] ParseProcedureEx                 : 0x0 [Type: long (__cdecl*)(void *,void *,_ACCESS_STATE *,char,unsigned long,_UNICODE_STRING *,_UNICODE_STRING *,void *,_SECURITY_QUALITY_OF_SERVICE *,_OB_EXTENDED_PARSE_PARAMETERS *,void * *)]
[+0x058] SecurityProcedure                 : 0xfffff8047eff57b0 [Type: long (__cdecl*)(void *,_SECURITY_OPERATION_CODE,unsigned long *,void *,unsigned long *,void * *,_POOL_TYPE,_GENERIC_MAPPING *,char)]
[+0x060] QueryNameProcedure               : 0x0 [Type: long (__cdecl*)(void *,unsigned char,_OBJECT_NAME_INFORMATION *,unsigned long,unsigned long *,char)]
[+0x068] OkayToCloseProcedure             : 0x0 [Type: unsigned char (__cdecl*)(_EPROCESS *,void *,void *,char)]
[+0x070] WaitObjectFlagMask              : 0x0 [Type: unsigned long]
[+0x074] WaitObjectFlagOffset            : 0x0 [Type: unsigned short]
[+0x076] WaitObjectPointerOffset         : 0x0 [Type: unsigned short]

```

Type objects can't be manipulated from user mode because the Object Manager supplies no services for them. However, some of the attributes they define are visible through certain native services and through Windows API routines. The information stored in the type initializers is described in Table 8-22.

TABLE 8-22 Type initializer fields

Attribute	Purpose
Type name	The name for objects of this type (Process, Event, ALPC Port, and so on).
Pool type	Indicates whether objects of this type should be allocated from paged or non-paged memory.
Default quota charges	Default paged and non-paged pool values to charge to process quotas.
Valid access mask	The types of access a thread can request when opening a handle to an object of this type (read, write, terminate, suspend, and so on).
Generic access rights mapping	A mapping between the four generic access rights (read, write, execute, and all) to the type-specific access rights.

Attribute	Purpose
Retain access	Access rights that can never be removed by any third-party Object Manager callbacks (part of the callback list described earlier).
Flags	Indicate whether objects must never have names (such as process objects), whether their names are case-sensitive, whether they require a security descriptor, whether they should be cache aligned (requiring a padding subheader), whether they support object-filtering callbacks, and whether a handle database (handle information subheader) and/or a type-list linkage (creator information subheader) should be maintained. The <i>use default object</i> flag also defines the behavior for the <i>default object</i> field shown later in this table. Finally, the <i>use extended parameters</i> flag enables usage of the extended parse procedure method, described later.
Object type code	Used to describe the type of object this is (versus comparing with a well-known name value). File objects set this to 1, synchronization objects set this to 2, and thread objects set this to 4. This field is also used by ALPC to store handle attribute information associated with a message.
Invalid attributes	Specifies object attribute flags (shown earlier in Table 8-20) that are invalid for this object type.
Default object	Specifies the internal Object Manager event that should be used during waits for this object, if the object type creator requested one. Note that certain objects, such as File objects and ALPC port objects already contain embedded dispatcher objects; in this case, this field is a flag that indicates that the following wait object mask/offset/pointer fields should be used instead.
Wait object flags, pointer, offset	Allows the Object Manager to generically locate the underlying kernel dispatcher object that should be used for synchronization when one of the generic wait services shown earlier (<i>WaitForSingleObject</i> , etc.) is called on the object.
Methods	One or more routines that the Object Manager calls automatically at certain points in an object's lifetime or in response to certain user-mode calls.

Synchronization, one of the attributes visible to Windows applications, refers to a thread's ability to synchronize its execution by waiting for an object to change from one state to another. A thread can synchronize with executive job, process, thread, file, event, semaphore, mutex, timer, and many other different kinds of objects. Yet, other executive objects don't support synchronization. An object's ability to support synchronization is based on three possibilities:

- The executive object is a wrapper for a dispatcher object and contains a dispatcher header, a kernel structure that is covered in the section "Low-IRQL synchronization" later in this chapter.
- The creator of the object type requested a *default object*, and the Object Manager provided one.
- The executive object has an embedded dispatcher object, such as an event somewhere inside the object body, and the object's owner supplied its offset (or pointer) to the Object Manager when registering the object type (described in Table 8-14).

Object methods

The last attribute in Table 8-22, methods, comprises a set of internal routines that are similar to C++ constructors and destructors—that is, routines that are automatically called when an object is created or destroyed. The Object Manager extends this idea by calling an object method in other situations as well, such as when someone opens or closes a handle to an object or when someone attempts to change the protection on an object. Some object types specify methods whereas others don't, depending on how the object type is to be used.

When an executive component creates a new object type, it can register one or more methods with the Object Manager. Thereafter, the Object Manager calls the methods at well-defined points in the lifetime of objects of that type, usually when an object is created, deleted, or modified in some way. The methods that the Object Manager supports are listed in Table 8-23.

TABLE 8-23 Object methods

Method	When Method Is Called
Open	When an object handle is created, opened, duplicated, or inherited
Close	When an object handle is closed
Delete	Before the Object Manager deletes an object
Query name	When a thread requests the name of an object
Parse	When the Object Manager is searching for an object name
Dump	Not used
Okay to close	When the Object Manager is instructed to close a handle
Security	When a process reads or changes the protection of an object, such as a file, that exists in a secondary object namespace

One of the reasons for these object methods is to address the fact that, as you've seen, certain object operations are generic (close, duplicate, security, and so on). Fully generalizing these generic routines would have required the designers of the Object Manager to anticipate all object types. Not only would this add extreme complexity to the kernel, but the routines to create an object type are actually exported by the kernel! Because this enables external kernel components to create their own object types, the kernel would be unable to anticipate potential custom behaviors. Although this functionality is not documented for driver developers, it is internally used by `Pcw.sys`, `Dxgkrnl.sys`, `Win32k.sys`, `FltMgr.sys`, and others, to define `WindowStation`, `Desktop`, `PcwObject`, `Dxgk*`, `FilterCommunication/ConnectionPort`, `NdisCmState`, and other objects. Through object-method extensibility, these drivers can define routines for handling operations such as delete and query.

Another reason for these methods is simply to allow a sort of virtual constructor and destructor mechanism in terms of managing an object's lifetime. This allows an underlying component to perform additional actions during handle creation and closure, as well as during object destruction. They even allow prohibiting handle closure and creation, when such actions are undesired—for example, the protected process mechanism described in Part 1, Chapter 3, leverages a custom handle creation method to prevent less protected processes from opening handles to more protected ones. These methods also provide visibility into internal Object Manager APIs such as duplication and inheritance, which are delivered through generic services.

Finally, because these methods also override the parse and query name functionality, they can be used to implement a secondary namespace outside of the purview of the Object Manager. In fact, this is how File and Key objects work—their namespace is internally managed by the file system driver and the configuration manager, and the Object Manager only ever sees the `\REGISTRY` and `\Device\HarddiskVolumeN` object. A little later, we'll provide details and examples for each of these methods.

The Object Manager only calls routines if their pointer is not set to NULL in the type initializer—with one exception: the *security* routine, which defaults to *SeDefaultObjectMethod*. This routine does not need to know the internal structure of the object because it deals only with the security descriptor for the object, and you've seen that the pointer to the security descriptor is stored in the generic object header, not inside the object body. However, if an object does require its own additional security checks, it can define a custom security routine, which again comes into play with File and Key objects that store security information in a way that's managed by the file system or configuration manager directly.

The Object Manager calls the *open* method whenever it creates a handle to an object, which it does when an object is created, opened, duplicated, or inherited. For example, the WindowStation and Desktop objects provide an open method. Indeed, the WindowStation object type requires an open method so that Win32k.sys can share a piece of memory with the process that serves as a desktop-related memory pool.

An example of the use of a close method occurs in the I/O system. The I/O manager registers a close method for the file object type, and the Object Manager calls the close method each time it closes a file object handle. This close method checks whether the process that is closing the file handle owns any outstanding locks on the file and, if so, removes them. Checking for file locks isn't something the Object Manager itself can or should do.

The Object Manager calls a delete method, if one is registered, before it deletes a temporary object from memory. The memory manager, for example, registers a delete method for the section object type that frees the physical pages being used by the section. It also verifies that any internal data structures the memory manager has allocated for a section are deleted before the section object is deleted. Once again, the Object Manager can't do this work because it knows nothing about the internal workings of the memory manager. Delete methods for other types of objects perform similar functions.

The parse method (and similarly, the query name method) allows the Object Manager to relinquish control of finding an object to a secondary Object Manager if it finds an object that exists outside the Object Manager namespace. When the Object Manager looks up an object name, it suspends its search when it encounters an object in the path that has an associated parse method. The Object Manager calls the parse method, passing to it the remainder of the object name it is looking for. There are two namespaces in Windows in addition to the Object Manager's: the registry namespace, which the configuration manager implements, and the file system namespace, which the I/O manager implements with the aid of file system drivers. (See Chapter 10 for more information on the configuration manager and Chapter 6 in Part 1 for more details about the I/O manager and file system drivers.)

For example, when a process opens a handle to the object named `\Device\HarddiskVolume1\docs\resume.doc`, the Object Manager traverses its name tree until it reaches the device object named *HarddiskVolume1*. It sees that a parse method is associated with this object, and it calls the method, passing to it the rest of the object name it was searching for—in this case, the string `docs\resume.doc`. The parse method for device objects is an I/O routine because the I/O manager defines the device object type and registers a parse method for it. The I/O manager's parse routine takes the name string and passes it to the appropriate file system, which finds the file on the disk and opens it.

The security method, which the I/O system also uses, is similar to the parse method. It is called whenever a thread tries to query or change the security information protecting a file. This information is different for files than for other objects because security information is stored in the file itself rather than in memory. The I/O system therefore must be called to find the security information and read or change it.

Finally, the okay-to-close method is used as an additional layer of protection around the malicious—or incorrect—closing of handles being used for system purposes. For example, each process has a handle to the Desktop object or objects on which its thread or threads have windows visible. Under the standard security model, it is possible for those threads to close their handles to their desktops because the process has full control of its own objects. In this scenario, the threads end up without a desktop associated with them—a violation of the windowing model. Win32k.sys registers an okay-to-close routine for the Desktop and WindowStation objects to prevent this behavior.

Object handles and the process handle table

When a process creates or opens an object by name, it receives a *handle* that represents its access to the object. Referring to an object by its handle is faster than using its name because the Object Manager can skip the name lookup and find the object directly. As briefly referenced earlier, processes can also acquire handles to objects by inheriting handles at process creation time (if the creator specifies the inherit handle flag on the *CreateProcess* call and the handle was marked as inheritable, either at the time it was created or afterward by using the Windows *SetHandleInformation* function) or by receiving a duplicated handle from another process. (See the Windows *DuplicateHandle* function.)

All user-mode processes must own a handle to an object before their threads can use the object. Using handles to manipulate system resources isn't a new idea. C and C++ run-time libraries, for example, return handles to opened files. Handles serve as indirect pointers to system resources; this indirection keeps application programs from fiddling directly with system data structures.

Object handles provide additional benefits. First, except for what they refer to, there is no difference between a file handle, an event handle, and a process handle. This similarity provides a consistent interface to reference objects, regardless of their type. Second, the Object Manager has the exclusive right to create handles and to locate an object that a handle refers to. This means that the Object Manager can scrutinize every user-mode action that affects an object to see whether the security profile of the caller allows the operation requested on the object in question.



Note Executive components and device drivers can access objects directly because they are running in kernel mode and therefore have access to the object structures in system memory. However, they must declare their usage of the object by incrementing the reference count so that the object won't be deallocated while it's still being used. (See the section "Object retention" later in this chapter for more details.) To successfully make use of this object, however, device drivers need to know the internal structure definition of the object, and this is not provided for most objects. Instead, device drivers are encouraged to use the appropriate kernel APIs to modify or read information from the object. For example, although device drivers can get a pointer to the Process object (EPROCESS), the structure is opaque, and the *Ps** APIs must be used instead. For other objects, the type itself is opaque (such as most executive objects that wrap a dispatcher object—for example, events or mutexes). For these objects, drivers must use the same system calls that user-mode applications end up calling (such as *ZwCreateEvent*) and use handles instead of object pointers.

EXPERIMENT: Viewing open handles

Run Process Explorer and make sure the lower pane is enabled and configured to show open handles. (Click on **View, Lower Pane View**, and then **Handles**.) Then open a command prompt and view the handle table for the new *Cmd.exe* process. You should see an open file handle to the current directory. For example, assuming the current directory is *C:\Users\Public*, Process Explorer shows the following:

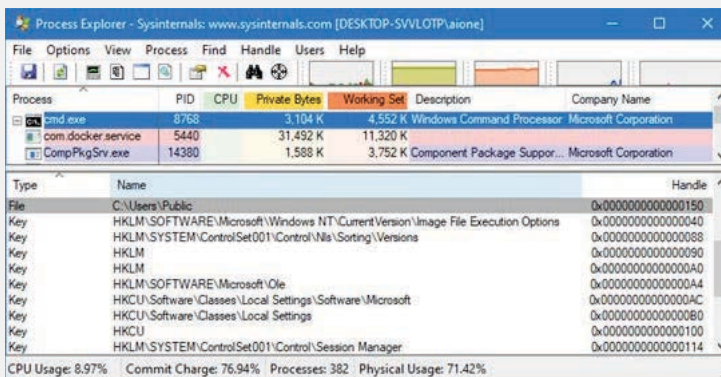

Now pause Process Explorer by pressing the spacebar or selecting **View, Update Speed** and choosing **Pause**. Then change the current directory with the **cd** command and press **F5** to refresh the display. You will see in Process Explorer that the handle to the previous current directory is closed, and a new handle is opened to the new current directory. The previous handle is highlighted in red, and the new handle is highlighted in green.

Process Explorer's differences-highlighting feature makes it easy to see changes in the handle table. For example, if a process is leaking handles, viewing the handle table with Process Explorer can quickly show what handle or handles are being opened but not closed. (Typically, you see a long list of handles to the same object.) This information can help the programmer find the handle leak.

Resource Monitor also shows open handles to named handles for the processes you select by checking the boxes next to their names. The figure shows the command prompt's open handles:

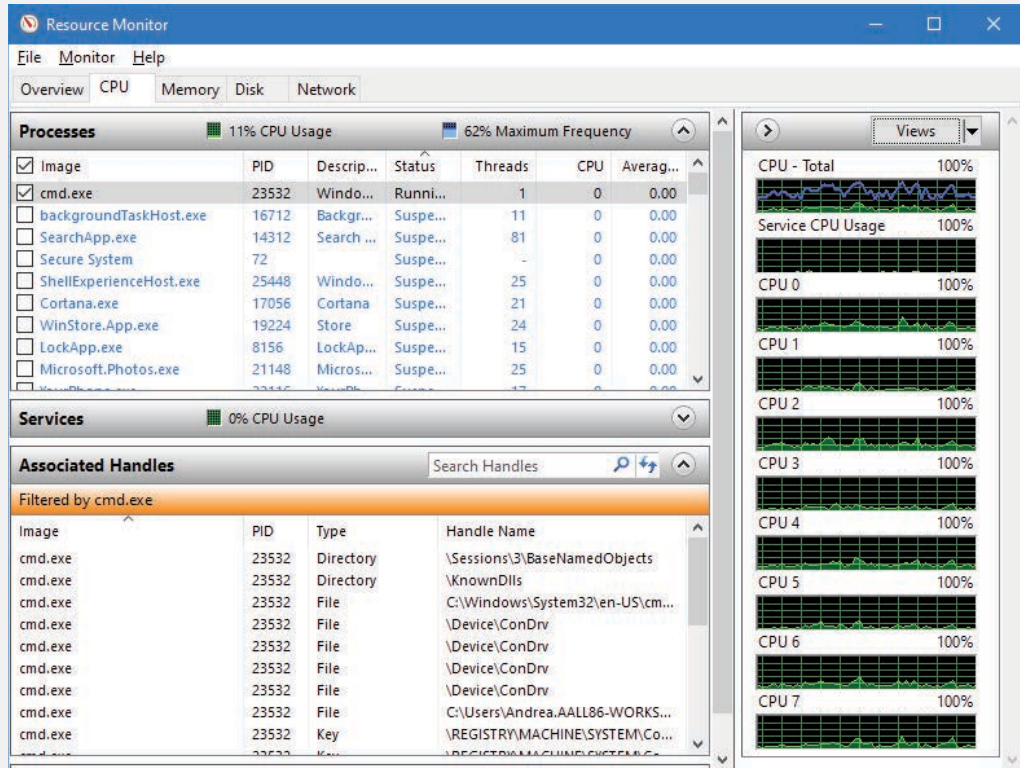

You can also display the open handle table by using the command-line Handle tool from Sysinternals. For example, note the following partial output of Handle when examining the file object handles located in the handle table for a Cmd.exe process before and after changing the directory. By default, Handle filters out non-file handles unless the `-a` switch is used, which displays all the handles in the process, similar to Process Explorer.

```
C:\Users\aione>\sysint\handle.exe -p 8768 -a users
Nthandle v4.22 - Handle viewer
Copyright (C) 1997-2019 Mark Russinovich
Sysinternals - www.sysinternals.com
cmd.exe          pid: 8768    type: File          150: C:\Users\Public
```

An *object handle* is an index into a process-specific *handle table*, pointed to by the executive process (*EPROCESS*) block (described in Chapter 3 of Part 1). The index is multiplied by 4 (shifted 2 bits) to make room for per-handle bits that are used by certain API behaviors—for example, inhibiting notifications on I/O completion ports or changing how process debugging works. Therefore, the first handle index is 4, the second 8, and so on. Using handle 5, 6, or 7 simply redirects to the same object as handle 4, while 9, 10, and 11 would reference the same object as handle 8.

A process's handle table contains pointers to all the objects that the process currently has opened a handle to, and handle values are aggressively reused, such that the next new handle index will reuse an existing closed handle index if possible. Handle tables, as shown in Figure 8-33, are implemented as a three-level scheme, similar to the way that the legacy x86 memory management unit implemented virtual-to-physical address translation but with a cap of 24 bits for compatibility reasons, resulting in a maximum of 16,777,215 ($2^{24}-1$) handles per process. Figure 8-34 describes instead the handle table entry layout on Windows. To save on kernel memory costs, only the lowest-level handle table is allocated on process creation—the other levels are created as needed. The subhandle table consists of as many entries as will fit in a page minus one entry that is used for handle auditing. For example, for 64-bit systems, a page is 4096 bytes, divided by the size of a handle table entry (16 bytes), which is 256, minus 1, which is a total of 255 entries in the lowest-level handle table. The mid-level handle table contains a full page of pointers to subhandle tables, so the number of subhandle tables depends on the size of the page and the size of a pointer for the platform. Again using 64-bit systems as an example, this gives us $4096/8$, or 512 entries. Due to the cap of 24 bits, only 32 entries are allowed in the top-level pointer table. If we multiply things together, we arrive at $32*512*255$ or 16,711,680 handles.

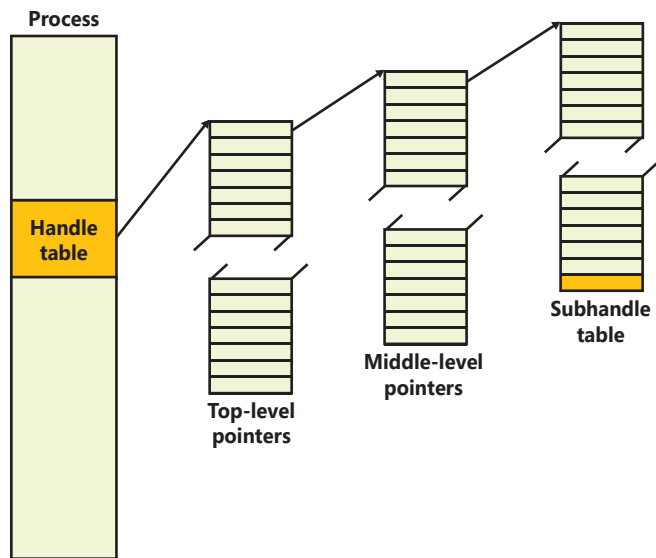

FIGURE 8-33 Windows process handle table architecture.

EXPERIMENT: Creating the maximum number of handles

The test program Testlimit from Sysinternals has an option to open handles to an object until it cannot open any more handles. You can use this to see how many handles can be created in a single process on your system. Because handle tables are allocated from paged pool, you might run out of paged pool before you hit the maximum number of handles that can be created in a single process. To see how many handles you can create on your system, follow these steps:

1. Download the Testlimit executable file corresponding to the 32-bit/64-bit Windows you need from <https://docs.microsoft.com/en-us/sysinternals/downloads/testlimit>.
2. Run Process Explorer, click **View**, and then click **System Information**. Then click the **Memory** tab. Notice the current and maximum size of paged pool. (To display the maximum pool size values, Process Explorer must be configured properly to access the symbols for the kernel image, Ntoskrnl.exe.) Leave this system information display running so that you can see pool utilization when you run the Testlimit program.
3. Open a command prompt.
4. Run the Testlimit program with the `-h` switch (do this by typing **testlimit -h**). When Testlimit fails to open a new handle, it displays the total number of handles it was able to create. If the number is less than approximately 16 million, you are probably running out of paged pool before hitting the theoretical per-process handle limit.
5. Close the Command Prompt window; doing this kills the Testlimit process, thus closing all the open handles.

As shown in Figure 8-34, on 32-bit systems, each handle entry consists of a structure with two 32-bit members: a pointer to the object (with three flags consuming the bottom 3 bits, due to the fact that all objects are 8-byte aligned, and these bits can be assumed to be 0), and the granted access mask (out of which only 25 bits are needed, since generic rights are never stored in the handle entry) combined with two more flags and the *reference usage count*, which we describe shortly.

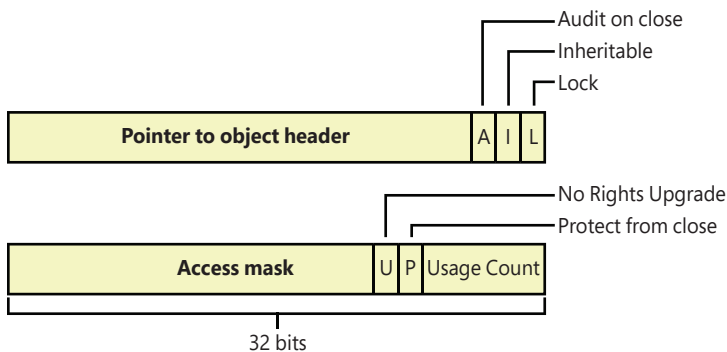

FIGURE 8-34 Structure of a 32-bit handle table entry.

On 64-bit systems, the same basic pieces of data are present but are encoded differently. For example, 44 bits are now needed to encode the object pointer (assuming a processor with four-level paging and 48-bits of virtual memory), since objects are 16-byte aligned, and thus the bottom *four* bits can now be assumed to be 0. This now allows encoding the “Protect from close” flag as part of the original three flags that were used on 32-bit systems as shown earlier, for a total of four flags. Another change is that the *reference usage count* is encoded in the remaining 16 bits next to the pointer, instead of next to the access mask. Finally, the “No rights upgrade” flag remains next to the access mask, but the remaining 6 bits are spare, and there are still 32-bits of alignment that are also currently spare, for a total of 16 bytes. And on LA57 systems with five levels of paging, things take yet another turn, where the pointer must now be 53 bits, reducing the usage count bits to only 7.

Since we mentioned a variety of flags, let’s see what these do. First, the first flag is a lock bit, indicating whether the entry is currently in use. Technically, it’s called “unlocked,” meaning that you should expect the bottom bit to normally be *set*. The second flag is the inheritance designation—that is, it indicates whether processes created by this process will get a copy of this handle in their handle tables. As already noted, handle inheritance can be specified on handle creation or later with the *SetHandleInformation* function. The third flag indicates whether closing the object should generate an audit message. (This flag isn’t exposed to Windows—the Object Manager uses it internally.) Next, the “Protect from close” bit indicates whether the caller is allowed to close this handle. (This flag can also be set with the *SetHandleInformation* function.) Finally, the “No rights upgrade” bit indicates whether access rights should be upgraded if the handle is duplicated to a process with higher privileges.

These last four flags are exposed to drivers through the *OBJECT_HANDLE_INFORMATION* structure that is passed in to APIs such as *ObReferenceObjectByHandle*, and map to *OBJ_INHERIT* (0x2), *OBJ_AUDIT_OBJECT_CLOSE* (0x4), *OBJ_PROTECT_CLOSE* (0x1), and *OBJ_NO_RIGHTS_UPGRADE* (0x8), which happen to match exactly with “holes” in the earlier OBJ_ attribute definitions that can be set when creating an object. As such, the object attributes, at runtime, end up encoding both specific behaviors of the object, as well as specific behaviors of a given handle to said object.

Finally, we mentioned the existence of a *reference usage count* in both the encoding of the pointer count field of the object’s header, as well as in the handle table entry. This handy feature encodes a cached number (based on the number of available bits) of preexisting references as part of each handle entry and then adds up the usage counts of all processes that have a handle to the object into the pointer count of the object’s header. As such, the pointer count is the number of handles, kernel references through *ObReferenceObject*, and the number of cached references for each handle.

Each time a process finishes to use an object, by dereferencing one of its handles—basically by calling *any* Windows API that takes a handle as input and ends up converting it into an object—the cached number of references is dropped, which is to say that the usage count decreases by 1, until it reaches 0, at which point it is no longer tracked. This allows one to infer exactly the number of times a given object has been utilized/accessed/managed through a specific process’s handle.

The debugger command **!trueref**, when executed with the **-v** flag, uses this feature as a way to show each handle referencing an object and exactly how many times it was used (if you count the number of consumed/dropped usage counts). In one of the next experiments, you’ll use this command to gain additional insight into an object’s usage.

System components and device drivers often need to open handles to objects that user-mode applications shouldn't have access to or that simply shouldn't be tied to a specific process to begin with. This is done by creating handles in the *kernel handle table* (referenced internally with the name *ObpKernelHandleTable*), which is associated with the System process. The handles in this table are accessible only from kernel mode and in any process context. This means that a kernel-mode function can reference the handle in any process context with no performance impact.

The Object Manager recognizes references to handles from the kernel handle table when the high bit of the handle is set—that is, when references to kernel-handle-table handles have values greater than 0x80000000 on 32-bit systems, or 0xFFFFFFFF80000000 on 64-bit systems (since handles are defined as pointers from a data type perspective, the compiler forces sign-extension).

The kernel handle table also serves as the handle table for the System and minimal processes, and as such, all handles created by the System process (such as code running in system threads) are implicitly kernel handles because the *ObpKernelHandleTable* symbol is set as the *ObjectTable* of the *EPROCESS* structure for these processes. Theoretically, this means that a sufficiently privileged user-mode process could use the *DuplicateHandle* API to extract a kernel handle out into user mode, but this attack has been mitigated since Windows Vista with the introduction of protected processes, which were described in Part 1.

Furthermore, as a security mitigation, *any* handle created by a kernel driver, with the previous mode set to *KernelMode*, is automatically turned into a kernel handle in recent versions of Windows to prevent handles from inadvertently leaking to user space applications.

EXPERIMENT: Viewing the handle table with the kernel debugger

The **!handle** command in the kernel debugger takes three arguments:

```
!handle <handle index> <flags> <processid>
```

The handle index identifies the handle entry in the handle table. (Zero means “display all handles.”) The first handle is index 4, the second 8, and so on. For example, typing **!handle 4** shows the first handle for the current process.

The flags you can specify are a bitmask, where bit 0 means “display only the information in the handle entry,” bit 1 means “display free handles (not just used handles),” and bit 2 means “display information about the object that the handle refers to.” The following command displays full details about the handle table for process ID 0x1540:

```
!kd> !handle 0 7 1540
```

```
PROCESS ffff898f239ac440
  SessionId: 0 Cid: 1540 Peb: 1ae33d000 ParentCid: 03c0
  DirBase: 211e1d000 ObjectTable: fffffc704b46dbd40 HandleCount: 641.
  Image: com.docker.service
```

```
Handle table at fffffc704b46dbd40 with 641 entries in use
```

```
0004: Object: ffff898f239589e0 GrantedAccess: 001f0003 (Protected) (Inherit) Entry:
fffffc704b45ff010
```



```
Object: ffff898f239589e0 Type: (ffff898f032e2560) Event
ObjectHeader: ffff898f239589b0 (new version)
HandleCount: 1 PointerCount: 32766
```

```
0008: Object: ffff898f23869770 GrantedAccess: 00000804 (Audit) Entry: ffffc704b45ff020
Object: ffff898f23869770 Type: (ffff898f033f7220) EtwRegistration
ObjectHeader: ffff898f23869740 (new version)
HandleCount: 1 PointerCount: 32764
```

Instead of having to remember what all these bits mean, and convert process IDs to hexadecimal, you can also use the debugger data model to access handles through the *Io.Handles* namespace of a process. For example, typing **dx @\$curprocess.Io.Handles[4]** will show the first handle for the current process, including the access rights and name, while the following command displays full details about the handles in PID 5440 (that is, 0x1540):

```
!kd> dx -r2 @$cursession.Processes[5440].Io.Handles
@$cursession.Processes[5440].Io.Handles
[0x4]
Handle           : 0x4
Type             : Event
GrantedAccess    : Delete | ReadControl | WriteDac | WriteOwner | Synch |
QueryState | ModifyState
Object           [Type: _OBJECT_HEADER]
[0x8]
Handle           : 0x8
Type             : EtwRegistration
GrantedAccess
Object           [Type: _OBJECT_HEADER]
[0xc]
Handle           : 0xc
Type             : Event
GrantedAccess    : Delete | ReadControl | WriteDac | WriteOwner | Synch |
QueryState | ModifyState
Object           [Type: _OBJECT_HEADER]
```

You can use the debugger data model with a LINQ predicate to perform more interesting searches, such as looking for named section object mappings that are Read/Write:

```
!kd> dx @$cursession.Processes[5440].Io.Handles.Where(h => (h.Type == "Section") &&
(h.GrantedAccess.MapWrite) && (h.GrantedAccess.MapRead)).Select(h => h.ObjectName)
@$cursession.Processes[5440].Io.Handles.Where(h => (h.Type == "Section") &&
(h.GrantedAccess.MapWrite) && (h.GrantedAccess.MapRead)).Select(h => h.ObjectName)
[0x16c]           : "Cor_Private_IPCBlock_v4_5440"
[0x170]           : "Cor_SxSPublic_IPCBlock"
[0x354]           : "windows_shell_global_counters"
[0x3b8]           : "UrlZonesSM_DESKTOP-SVVLOTP$"
[0x680]           : "NLS_CodePage_1252_3_2_0_0"
```

EXPERIMENT: Searching for open files with the kernel debugger

Although you can use Process Hacker, Process Explorer, Handle, and the OpenFiles.exe utility to search for open file handles, these tools are not available when looking at a crash dump or analyzing a system remotely. You can instead use the **!devhandles** command to search for handles opened to files on a specific volume. (See Chapter 11 for more information on devices, files, and volumes.)

1. First you need to pick the drive letter you are interested in and obtain the pointer to its *Device* object. You can use the **!object** command as shown here:

```
!kd> !object \Global??\C:
Object: fffffc704ae684970 Type: (ffff898f03295a60) SymbolicLink
ObjectHeader: fffffc704ae684940 (new version)
HandleCount: 0 PointerCount: 1
Directory Object: fffffc704ade04ca0 Name: C:
Flags: 00000000 ( Local )
Target String is '\Device\HarddiskVolume3'
Drive Letter Index is 3 (C:)
```

2. Next, use the **!object** command to get the *Device* object of the target volume name:

```
1: kd> !object \Device\HarddiskVolume1
Object: FFFF898F0820D8F0 Type: (fffffa8000ca0750) Device
```

3. Now you can use the pointer of the *Device* object with the **!devhandles** command. Each object shown points to a file:

```
!kd> !devhandles 0xFFFFF898F0820D8F0

Checking handle table for process 0xffff898f0327d300
Kernel handle table at fffffc704ade05580 with 7047 entries in use

PROCESS fffff898f0327d300
  SessionId: none Cid: 0004 Peb: 00000000 ParentCid: 0000
  DirBase: 001ad000 ObjectTable: fffffc704ade05580 HandleCount: 7023.
  Image: System

019c: Object: fffff898f080836a0 GrantedAccess: 0012019f (Protected) (Inherit)
(Audit) Entry: fffffc704ade28670
Object: fffff898f080836a0 Type: (ffff898f032f9820) File
  ObjectHeader: fffff898f08083670 (new version)
  HandleCount: 1 PointerCount: 32767
  Directory Object: 00000000 Name: \${Extend}\$RmMetadata\${TxfLog}\
  $TxfLog.b1f {HarddiskVolume4}
```

Although this extension works just fine, you probably noticed that it took about 30 seconds to a minute to begin seeing the first few handles. Instead, you can use the debugger data model to achieve the same effect with a LINQ predicate, which instantly starts returning results:

```
!kd> dx -r2 @$cursession.Processes.Select(p => p.Io.Handles.Where(h =>
  h.Type == "File").Where(f => f.Object.UnderlyingObject.DeviceObject ==
  (nt!_DEVICE_OBJECT*)0xFFFFF898F0820D8F0).Select(f =>
  f.Object.UnderlyingObject.FileName))
@$cursession.Processes.Select(p => p.Io.Handles.Where(h => h.Type == "File").
```

```

Where(f => f.Object.UnderlyingObject.DeviceObject == (nt!_DEVICE_OBJECT*)
0xFFFFF898F0820D8F0).Select(f => f.Object.UnderlyingObject.FileName)
[0x0]
[0x19c] : "\\$Extend\$RmMetadata\$TxfLog\$TxfLog.b1f" [Type: _UNICODE_STRING]
[0x2dc] : "\\$Extend\$RmMetadata\$Txf:$I30:$INDEX_ALLOCATION" [Type: _UNICODE_STRING]
[0x2e0] : "\\$Extend\$RmMetadata\$TxfLog\$TxfLogContainer000000000000000002"
[Type: _UNICODE_STRING]

```

Reserve Objects

Because objects represent anything from events to files to interprocess messages, the ability for applications and kernel code to create objects is essential to the normal and desired runtime behavior of any piece of Windows code. If an object allocation fails, this usually causes anything from loss of functionality (the process cannot open a file) to data loss or crashes (the process cannot allocate a synchronization object). Worse, in certain situations, the reporting of errors that led to object creation failure might themselves require new objects to be allocated. Windows implements two special *reserve objects* to deal with such situations: the User APC reserve object and the I/O Completion packet reserve object. Note that the reserve-object mechanism is fully extensible, and future versions of Windows might add other reserve object types—from a broad view, the reserve object is a mechanism enabling any kernel-mode data structure to be wrapped as an object (with an associated handle, name, and security) for later use.

As was discussed earlier in this chapter, APCs are used for operations such as suspension, termination, and I/O completion, as well as communication between user-mode applications that want to provide asynchronous callbacks. When a user-mode application requests a User APC to be targeted to another thread, it uses the *QueueUserApc* API in *Kernelbase.dll*, which calls the *NtQueueApcThread* system call. In the kernel, this system call attempts to allocate a piece of paged pool in which to store the *KAPC* control object structure associated with an APC. In low-memory situations, this operation fails, preventing the delivery of the APC, which, depending on what the APC was used for, could cause loss of data or functionality.

To prevent this, the user-mode application, can, on startup, use the *NtAllocateReserveObject* system call to request the kernel to preallocate the *KAPC* structure. Then the application uses a different system call, *NtQueueApcThreadEx*, that contains an extra parameter that is used to store the handle to the reserve object. Instead of allocating a new structure, the kernel attempts to acquire the reserve object (by setting its *InUse* bit to *true*) and uses it until the *KAPC* object is not needed anymore, at which point the reserve object is released back to the system. Currently, to prevent mismanagement of system resources by third-party developers, the reserve object API is available only internally through system calls for operating system components. For example, the RPC library uses reserved APC objects to guarantee that asynchronous callbacks will still be able to return in low-memory situations.

A similar scenario can occur when applications need failure-free delivery of an I/O completion port message or packet. Typically, packets are sent with the *PostQueuedCompletionStatus* API in *Kernelbase.dll*, which calls the *NtSetIoCompletion* API. Like the user APC, the kernel must allocate an I/O manager structure to contain the completion-packet information, and if this allocation fails, the packet cannot

be created. With reserve objects, the application can use the *NtAllocateReserveObject* API on startup to have the kernel preallocate the I/O completion packet, and the *NtSetIoCompletionEx* system call can be used to supply a handle to this reserve object, guaranteeing a successful path. Just like User APC reserve objects, this functionality is reserved for system components and is used both by the RPC library and the Windows Peer-To-Peer BranchCache service to guarantee completion of asynchronous I/O operations.

Object security

When you open a file, you must specify whether you intend to read or to write. If you try to write to a file that is open for read access, you get an error. Likewise, in the executive, when a process creates an object or opens a handle to an existing object, the process must specify a set of *desired access rights*—that is, what it wants to do with the object. It can request either a set of standard access rights (such as read, write, and execute) that apply to all object types or specific access rights that vary depending on the object type. For example, the process can request delete access or append access to a file object. Similarly, it might require the ability to suspend or terminate a thread object.

When a process opens a handle to an object, the Object Manager calls the *security reference monitor*, the kernel-mode portion of the security system, sending it the process's set of desired access rights. The security reference monitor checks whether the object's security descriptor permits the type of access the process is requesting. If it does, the reference monitor returns a set of *granted access rights* that the process is allowed, and the Object Manager stores them in the object handle it creates. How the security system determines who gets access to which objects is explored in Chapter 7 of Part 1.

Thereafter, whenever the process's threads use the handle through a service call, the Object Manager can quickly check whether the set of granted access rights stored in the handle corresponds to the usage implied by the object service the threads have called. For example, if the caller asked for read access to a section object but then calls a service to write to it, the service fails.

EXPERIMENT: Looking at object security

You can look at the various permissions on an object by using either Process Hacker, Process Explorer, WinObj, WinObjEx64, or AccessChk, which are all tools from Sysinternals or open-source tools available on GitHub. Let's look at different ways you can display the access control list (ACL) for an object:

- You can use WinObj or WinObjEx64 to navigate to any object on the system, including object directories, right-click the object, and select **Properties**. For example, select the BaseNamedObjects directory, select **Properties**, and click the **Security** tab. You should see a dialog box like the one shown next. Because WinObjEx64 supports a wider variety of object types, you'll be able to use this dialog on a larger set of system resources.

By examining the settings in the dialog box, you can see that the Everyone group doesn't have *delete* access to the directory, for example, but the SYSTEM account does (because this is where session 0 services with SYSTEM privileges will store their objects).

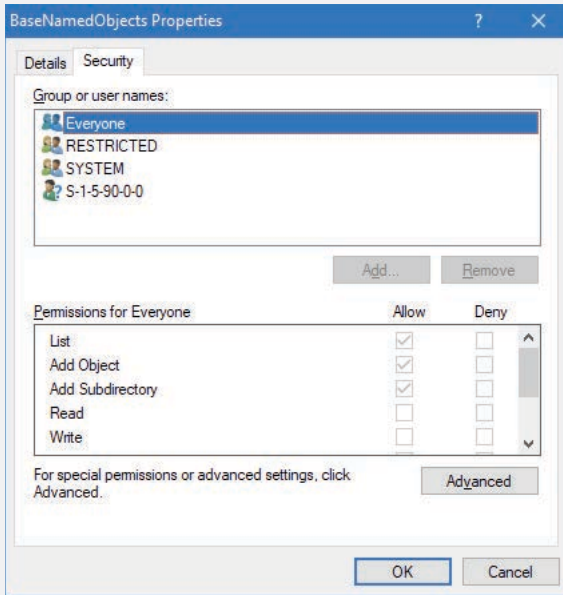

- Instead of using WinObj or WinObjEx64, you can view the handle table of a process using Process Explorer, as shown in the experiment “Viewing open handles” earlier in this chapter, or using Process Hacker, which has a similar view. Look at the handle table for the Explorer.exe process. You should notice a Directory object handle to the \Sessions\n\BaseNamedObjects directory (where n is an arbitrary session number defined at boot time. We describe the per-session namespace shortly.) You can double-click the object handle and then click the **Security** tab and see a similar dialog box (with more users and rights granted).
- Finally, you can use AccessChk to query the security information of any object by using the `-o` switch as shown in the following output. Note that using AccessChk will also show you the *integrity level* of the object. (See Chapter 7 of Part 1, for more information on integrity levels and the security reference monitor.)

```
C:\sysint>accesschk -o \Sessions\1\BaseNamedObjects
```

```
Accesschk v6.13 - Reports effective permissions for securable objects
Copyright (C) 2006-2020 Mark Russinovich
Sysinternals - www.sysinternals.com
```

```
\Sessions\1\BaseNamedObjects
Type: Directory
RW Window Manager\DWM-1
RW NT AUTHORITY\SYSTEM
RW DESKTOP-SVVLOTP\aione
RW DESKTOP-SVVLOTP\aione-S-1-5-5-0-841005
RW BUILTIN\Administrators
R Everyone
NT AUTHORITY\RESTRICTED
```

Windows also supports *Ex* (Extended) versions of the APIs—*CreateEventEx*, *CreateMutexEx*, *CreateSemaphoreEx*—that add another argument for specifying the access mask. This makes it possible for applications to use discretionary access control lists (DACLS) to properly secure their objects without breaking their ability to use the create object APIs to open a handle to them. You might be wondering why a client application would not simply use *OpenEvent*, which does support a desired access argument. Using the open object APIs leads to an inherent race condition when dealing with a failure in the open call—that is, when the client application has attempted to open the event before it has been created. In most applications of this kind, the open API is followed by a create API in the failure case. Unfortunately, there is no guaranteed way to make this create operation *atomic*—in other words, to occur only once.

Indeed, it would be possible for multiple threads and/or processes to have executed the create API concurrently, and all attempt to create the event at the same time. This race condition and the extra complexity required to try to handle it makes using the open object APIs an inappropriate solution to the problem, which is why the *Ex* APIs should be used instead.

Object retention

There are two types of objects: temporary and permanent. Most objects are temporary—that is, they remain while they are in use and are freed when they are no longer needed. Permanent objects remain until they are explicitly freed. Because most objects are temporary, the rest of this section describes how the Object Manager implements *object retention*—that is, retaining temporary objects only as long as they are in use and then deleting them.

Because all user-mode processes that access an object must first open a handle to it, the Object Manager can easily track how many of these processes, and which ones, are using an object. Tracking these handles represents one part of implementing retention. The Object Manager implements object retention in two phases. The first phase is called *name retention*, and it is controlled by the number of open handles to an object that exists. Every time a process opens a handle to an object, the Object Manager increments the open handle counter in the object's header. As processes finish using the object and close their handles to it, the Object Manager decrements the open handle counter. When the counter drops to 0, the Object Manager deletes the object's name from its global namespace. This deletion prevents processes from opening a handle to the object.

The second phase of object retention is to stop retaining the objects themselves (that is, to delete them) when they are no longer in use. Because operating system code usually accesses objects by using pointers instead of handles, the Object Manager must also record how many object pointers it has dispensed to operating system processes. As we saw, it increments a *reference count* for an object each time it gives out a pointer to the object, which is called the *pointer count*; when kernel-mode components finish using the pointer, they call the Object Manager to decrement the object's reference count. The system also increments the reference count when it increments the handle count, and likewise decrements the reference count when the handle count decrements because a handle is also a reference to the object that must be tracked.

Finally, we also described *usage reference count*, which adds *cached* references to the pointer count and is decremented each time a process uses a handle. The usage reference count has been added

since Windows 8 for performance reasons. When the kernel is asked to obtain the object pointer from its handle, it can do the resolution without acquiring the global handle table lock. This means that in newer versions of Windows, the handle table entry described in the “Object handles and the process handle table” section earlier in this chapter contains a usage reference counter, which is initialized the first time an application or a kernel driver uses the handle to the object. Note that in this context, the verb *use* refers to the act of resolving the object pointer from its handle, an operation performed in kernel by APIs like the *ObReferenceObjectByHandle*.

Let’s explain the three counts through an example, like the one shown in Figure 8-35. The image represents two event objects that are in use in a 64-bit system. Process A creates the first event, obtaining a handle to it. The event has a name, which implies that the Object Manager inserts it in the correct directory object (`\BaseNamedObjects`, for example), assigning an initial reference count to 2 and the handle count to 1. After initialization is complete, Process A waits on the first event, an operation that allows the kernel to use (or reference) the handle to it, which assigns the handle’s *usage* reference count to 32,767 (0x7FFF in hexadecimal, which sets 15 bits to 1). This value is added to the first event object’s reference count, which is also increased by one, bringing the final value to 32,770 (while the handle count is still 1.)

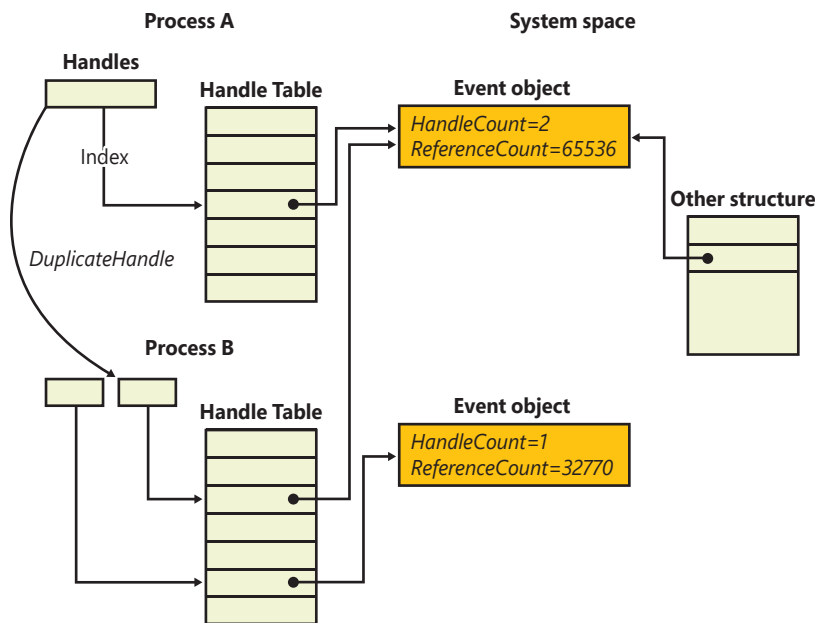

FIGURE 8-35 Handles and reference counts.

Process B initializes, creates the second named event, and signals it. The last operation uses (references) the second event, allowing it also to reach a reference value of 32,770. Process B then opens the first event (allocated by process A). The operation lets the kernel create a new handle (valid only in the Process B address space), which adds both a handle count and reference count to the first event object, bringing its counters to 2 and 32,771. (Remember, the new handle table entry still has its *usage* reference count uninitialized.) Process B, before signaling the first event, uses its handle three times:

the first operation initializes the handle's *usage* reference count to 32,767. The value is added to the object reference count, which is further increased by 1 unit, and reaches the overall value of 65,539. Subsequent operations on the handle simply *decreases* the *usage* reference count without touching the object's reference count. When the kernel finishes using an object, it always dereferences its pointer, though—an operation that releases a reference count on the kernel object. Thus, after the four uses (including the signaling operation), the first object reaches a handle count of 2 and reference count of 65,535. In addition, the first event is being referenced by some kernel-mode structure, which brings its final reference count to 65,536.

When a process closes a handle to an object (an operation that causes the *NtClose* routine to be executed in the kernel), the Object Manager knows that it needs to subtract the handle *usage* reference counter from the object's reference counter. This allows the correct dereference of the handle. In the example, even if Processes A and B both close their handles to the first object, the object would continue to exist because its reference count will become 1 (while its handle count would be 0). However, when Process B closes its handle to the second event object, the object would be deallocated, because its reference count reaches 0.

This behavior means that even after an object's open handle counter reaches 0, the object's reference count might remain positive, indicating that the operating system is still using the object in some way. Ultimately, it is only when the reference count drops to 0 that the Object Manager deletes the object from memory. This deletion has to respect certain rules and also requires cooperation from the caller in certain cases. For example, because objects can be present both in paged or nonpaged pool memory (depending on the settings located in their object types), if a dereference occurs at an IRQL level of *DISPATCH_LEVEL* or higher and this dereference causes the pointer count to drop to 0, the system would crash if it attempted to immediately free the memory of a paged-pool object. (Recall that such access is illegal because the page fault will never be serviced.) In this scenario, the Object Manager performs a *deferred delete* operation, queuing the operation on a worker thread running at passive level (IRQL 0). We'll describe more about system worker threads later in this chapter.

Another scenario that requires deferred deletion is when dealing with Kernel Transaction Manager (KTM) objects. In some scenarios, certain drivers might hold a lock related to this object, and attempting to delete the object will result in the system attempting to acquire this lock. However, the driver might never get the chance to release its lock, causing a deadlock. When dealing with KTM objects, driver developers must use *ObDereferenceObjectDeferDelete* to force deferred deletion regardless of IRQL level. Finally, the I/O manager also uses this mechanism as an optimization so that certain I/Os can complete more quickly, instead of waiting for the Object Manager to delete the object.

Because of the way object retention works, an application can ensure that an object and its name remain in memory simply by keeping a handle open to the object. Programmers who write applications that contain two or more cooperating processes need not be concerned that one process might delete an object before the other process has finished using it. In addition, closing an application's object handles won't cause an object to be deleted if the operating system is still using it. For example, one process might create a second process to execute a program in the background; it then immediately closes its handle to the process. Because the operating system needs the second process to run the program, it maintains a reference to its process object. Only when the background program finishes executing does the Object Manager decrement the second process's reference count and then delete it.

Because object leaks can be dangerous to the system by leaking kernel pool memory and eventually causing systemwide memory starvation—and can break applications in subtle ways—Windows includes a number of debugging mechanisms that can be enabled to monitor, analyze, and debug issues with handles and objects. Additionally, WinDbg comes with two extensions that tap into these mechanisms and provide easy graphical analysis. Table 8-24 describes them.

TABLE 8-24 Debugging mechanisms for object handles

Mechanism	Enabled By	Kernel Debugger Extension
Handle Tracing Database	Kernel Stack Trace systemwide and/or per-process with the User Stack Trace option checked with Gflags.exe	<i>!htrace</i> <handle value> <process ID>
Object Reference Tracing	Per-process-name(s), or per-object-type-pool-tag(s), with Gflags.exe, under Object Reference Tracing	<i>!obtrace</i> <object pointer>
Object Reference Tagging	Drivers must call appropriate API	N/A

Enabling the handle-tracing database is useful when attempting to understand the use of each handle within an application or the system context. The *!htrace* debugger extension can display the stack trace captured at the time a specified handle was opened. After you discover a handle leak, the stack trace can pinpoint the code that is creating the handle, and it can be analyzed for a missing call to a function such as *CloseHandle*.

The object-reference-tracing *!obtrace* extension monitors even more by showing the stack trace for each new handle created as well as each time a handle is referenced by the kernel (and each time it is opened, duplicated, or inherited) and dereferenced. By analyzing these patterns, misuse of an object at the system level can be more easily debugged. Additionally, these reference traces provide a way to understand the behavior of the system when dealing with certain objects. Tracing processes, for example, display references from all the drivers on the system that have registered callback notifications (such as Process Monitor) and help detect rogue or buggy third-party drivers that might be referencing handles in kernel mode but never dereferencing them.



Note When enabling object-reference tracing for a specific object type, you can obtain the name of its pool tag by looking at the *key* member of the *OBJECT_TYPE* structure when using the **dx** command. Each object type on the system has a global variable that references this structure—for example, *PsProcessType*. Alternatively, you can use the **!object** command, which displays the pointer to this structure.

Unlike the previous two mechanisms, object-reference tagging is not a debugging feature that must be enabled with global flags or the debugger but rather a set of APIs that should be used by device-driver developers to reference and dereference objects, including *ObReferenceObjectWithTag* and *ObDereferenceObjectWithTag*. Similar to pool tagging (see Chapter 5 in Part 1 for more information on pool tagging), these APIs allow developers to supply a four-character tag identifying each reference/dereference pair. When using the *!obtrace* extension just described, the tag for each reference or dereference operation is also shown, which avoids solely using the call stack as a mechanism to identify where leaks or under-references might occur, especially if a given call is performed thousands of times by the driver.

Resource accounting

Resource accounting, like object retention, is closely related to the use of object handles. A positive open handle count indicates that some process is using that resource. It also indicates that some process is being charged for the memory the object occupies. When an object's handle count and reference count drop to 0, the process that was using the object should no longer be charged for it.

Many operating systems use a quota system to limit processes' access to system resources. However, the types of quotas imposed on processes are sometimes diverse and complicated, and the code to track the quotas is spread throughout the operating system. For example, in some operating systems, an I/O component might record and limit the number of files a process can open, whereas a memory component might impose a limit on the amount of memory that a process's threads can allocate. A process component might limit users to some maximum number of new processes they can create or a maximum number of threads within a process. Each of these limits is tracked and enforced in different parts of the operating system.

In contrast, the Windows Object Manager provides a central facility for resource accounting. Each object header contains an attribute called *quota charges* that records how much the Object Manager subtracts from a process's allotted paged and/or nonpaged pool quota when a thread in the process opens a handle to the object.

Each process on Windows points to a quota structure that records the limits and current values for nonpaged-pool, paged-pool, and page-file usage. These quotas default to 0 (no limit) but can be specified by modifying registry values. (You need to add/edit *NonPagedPoolQuota*, *PagedPoolQuota*, and *PagingFileQuota* under HKLM\SYSTEM\CurrentControlSet\Control\Session Manager\Memory Management.) Note that all the processes in an interactive session share the same quota block (and there's no documented way to create processes with their own quota blocks).

Object names

An important consideration in creating a multitude of objects is the need to devise a successful system for keeping track of them. The Object Manager requires the following information to help you do so:

- A way to distinguish one object from another
- A method for finding and retrieving a particular object

The first requirement is served by allowing names to be assigned to objects. This is an extension of what most operating systems provide—the ability to name selected resources, files, pipes, or a block of shared memory, for example. The executive, in contrast, allows any resource represented by an object to have a name. The second requirement, finding and retrieving an object, is also satisfied by object names. If the Object Manager stores objects by name, it can find an object by looking up its name.

Object names also satisfy a third requirement, which is to allow processes to share objects. The executive's object namespace is a global one, visible to all processes in the system. One process can create an object and place its name in the global namespace, and a second process can open a handle to the object by specifying the object's name. If an object isn't meant to be shared in this way, its creator doesn't need to give it a name.

To increase efficiency, the Object Manager doesn't look up an object's name each time someone uses the object. Instead, it looks up a name under only two circumstances. The first is when a process creates a named object: the Object Manager looks up the name to verify that it doesn't already exist before storing the new name in the global namespace. The second is when a process opens a handle to a named object: The Object Manager looks up the name, finds the object, and then returns an object handle to the caller; thereafter, the caller uses the handle to refer to the object. When looking up a name, the Object Manager allows the caller to select either a case-sensitive or case-insensitive search, a feature that supports Windows Subsystem for Linux (WSL) and other environments that use case-sensitive file names.

Object directories

The object directory object is the Object Manager's means for supporting this hierarchical naming structure. This object is analogous to a file system directory and contains the names of other objects, possibly even other object directories. The object directory object maintains enough information to translate these object names into pointers to the object headers of the objects themselves. The Object Manager uses the pointers to construct the object handles that it returns to user-mode callers. Both kernel-mode code (including executive components and device drivers) and user-mode code (such as subsystems) can create object directories in which to store objects.

Objects can be stored anywhere in the namespace, but certain object types will always appear in certain directories due to the fact they are created by a specialized component in a specific way. For example, the I/O manager creates an object directory named `\Driver`, which contains the names of objects representing loaded non-file-system kernel-mode drivers. Because the I/O manager is the only component responsible for the creation of Driver objects (through the `IoCreateDriver` API), only Driver objects should exist there.

Table 8-25 lists the standard object directories found on all Windows systems and what types of objects you can expect to see stored there. Of the directories listed, only `\AppContainerNamedObjects`, `\BaseNamedObjects`, and `\Global??` are generically available for use by standard Win32 or UWP applications that stick to documented APIs. (See the "Session namespace" section later in this chapter for more information.)

TABLE 8-25 Standard object directories

Directory	Types of Object Names Stored
<code>\AppContainerNamedObjects</code>	Only present under the <code>\Sessions</code> object directory for non-Session 0 interactive sessions; contains the named kernel objects created by Win32 or UWP APIs from within processes that are running in an App Container.
<code>\ArcName</code>	Symbolic links mapping ARC-style paths to NT-style paths.
<code>\BaseNamedObjects</code>	Global mutexes, events, semaphores, waitable timers, jobs, ALPC ports, symbolic links, and section objects.
<code>\Callback</code>	Callback objects (which only drivers can create).

Directory	Types of Object Names Stored
\Device	Device objects owned by most drivers except file system and filter manager devices, plus the VolumesSafeForWriteAccess event, and certain symbolic links such as SystemPartition and BootPartition. Also contains the PhysicalMemory section object that allows direct access to RAM by kernel components. Finally, contains certain object directories, such as Http used by the Http.sys accelerator driver, and HarddiskN directories for each physical hard drive.
\Driver	Driver objects whose type is not "File System Driver" or "File System Recognizer" (<i>SERVICE_FILE_SYSTEM_DRIVER</i> or <i>SERVICE_RECOGNIZER_DRIVER</i>).
\DriverStore(s)	Symbolic links for locations where OS drivers can be installed and managed from. Typically, at least SYSTEM which points to \SystemRoot, but can contain more entries on Windows 10X devices.
\FileSystem	File-system driver objects (<i>SERVICE_FILE_SYSTEM_DRIVER</i>) and file-system recognizer (<i>SERVICE_RECOGNIZER_DRIVER</i>) driver and device objects. The Filter Manager also creates its own device objects under the Filters object directory.
\GLOBAL??	Symbolic link objects that represent MS-DOS device names. (The \Sessions\0\DosDevices\<LUID>\Global directories are symbolic links to this directory.)
\KernelObjects	Contains event objects that signal kernel pool resource conditions, the completion of certain operating system tasks, as well as Session objects (at least Session0) representing each interactive session, and Partition objects (at least MemoryPartition0) for each memory partition. Also contains the mutex used to synchronize access to the Boot Configuration Database (BC). Finally, contains dynamic symbolic links that use a custom callback to refer to the correct partition for physical memory and commit resource conditions, and for memory error detection.
\KnownDlls	Section objects for the known DLLs mapped by SMSS at startup time, and a symbolic link containing the path for known DLLs.
\KnownDlls32	On a 64-bit Windows installation, \KnownDlls contains the native 64-bit binaries, so this directory is used instead to store WoW64 32-bit versions of those DLLs.
\NLS	Section objects for mapped national language support (NLS) tables.
\ObjectTypes	Object type objects for each object type created by <i>ObCreateObjectTypeEx</i> .
\RPC Control	ALPC ports created to represent remote procedure call (RPC) endpoints when Local RPC (ncalrpc) is used. This includes explicitly named endpoints, as well as auto-generated COM (OLEXXXXX) port names and unnamed ports (LRPC-XXXX, where XXXX is a randomly generated hexadecimal value).
\Security	ALPC ports and events used by objects specific to the security subsystem.
\Sessions	Per-session namespace directory. (See the next subsection.)
\Silo	If at least one Windows Server Container has been created, such as by using Docker for Windows with non-VM containers, contains object directories for each Silo ID (the Job ID of the root job for the container), which then contain the object namespace local to that Silo.
\UMDFCommunicationPorts	ALPC ports used by the User-Mode Driver Framework (UMDF).
\VmSharedMemory	Section objects used by virtualized instances (VAIL) of Win32k.sys and other window manager components on Windows 10X devices when launching legacy Win32 applications. Also contains the Host object directory to represent the other side of the connection.
\Windows	Windows subsystem ALPC ports, shared section, and window stations in the WindowStations object directory. Desktop Window Manager (DWM) also stores its ALPC ports, events, and shared sections in this directory, for non-Session 0 sessions. Finally, stores the Themes service section object.

Object names are global to a single computer (or to all processors on a multiprocessor computer), but they're not visible across a network. However, the Object Manager's parse method makes it possible to access named objects that exist on other computers. For example, the I/O manager, which supplies file-object services, extends the functions of the Object Manager to remote files. When asked to open a remote file object, the Object Manager calls a parse method, which allows the I/O manager to intercept the request and deliver it to a network redirector, a driver that accesses files across the network. Server code on the remote Windows system calls the Object Manager and the I/O manager on that system to find the file object and return the information back across the network.

Because the kernel objects created by non-app-container processes, through the Win32 and UWP API, such as mutexes, events, semaphores, waitable timers, and sections, have their names stored in a single object directory, no two of these objects can have the same name, even if they are of a different type. This restriction emphasizes the need to choose names carefully so that they don't collide with other names. For example, you could prefix names with a GUID and/or combine the name with the user's security identifier (SID)—but even that would only help with a single instance of an application per user.

The issue with name collision may seem innocuous, but one security consideration to keep in mind when dealing with named objects is the possibility of malicious *object name squatting*. Although object names in different sessions are protected from each other, there's no standard protection inside the current session namespace that can be set with the standard Windows API. This makes it possible for an unprivileged application running in the same session as a privileged application to access its objects, as described earlier in the object security subsection. Unfortunately, even if the object creator used a proper DACL to secure the object, this doesn't help against the *squatting* attack, in which the unprivileged application creates the object *before* the privileged application, thus denying access to the legitimate application.

Windows exposes the concept of a *private namespace* to alleviate this issue. It allows user-mode applications to create object directories through the *CreatePrivateNamespace* API and associate these directories with boundary descriptors created by the *CreateBoundaryDescriptor* API, which are special data structures protecting the directories. These descriptors contain SIDs describing which security principals are allowed access to the object directory. In this manner, a privileged application can be sure that unprivileged applications will not be able to conduct a denial-of-service attack against its objects. (This doesn't stop a privileged application from doing the same, however, but this point is moot.) Additionally, a boundary descriptor can also contain an integrity level, protecting objects possibly belonging to the same user account as the application based on the integrity level of the process. (See Chapter 7 of Part 1 for more information on integrity levels.)

One of the things that makes boundary descriptors effective mitigations against squatting attacks is that unlike objects, the creator of a boundary descriptor must have access (through the SID and integrity level) to the boundary descriptor. Therefore, an unprivileged application can only create an unprivileged boundary descriptor. Similarly, when an application wants to open an object in a private namespace, it must *open* the namespace using the same boundary descriptor that was used to create it. Therefore, a privileged application or service would provide a privileged boundary descriptor, which would not match the one created by the unprivileged application.

EXPERIMENT: Looking at the base named objects and private objects

You can see the list of base objects that have names with the WinObj tool from Sysinternals or with WinObjEx64. However, in this experiment, we use WinObjEx64 because it supports additional object types and because it can also show private namespaces. Run Winobjex64.exe, and click the BaseNamedObjects node in the tree, as shown here:

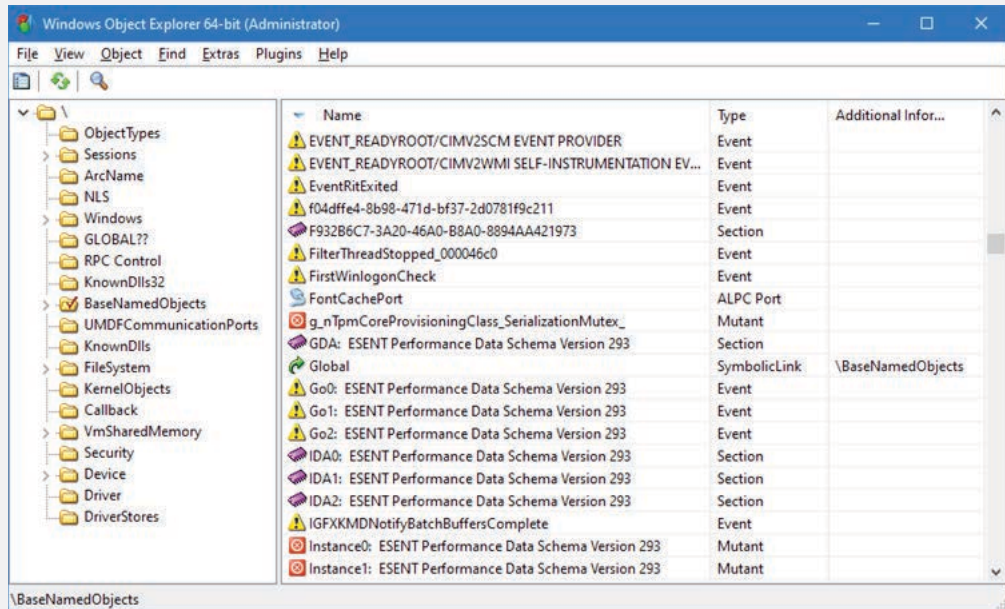

The named objects are listed on the right. The icons indicate the object type:

- Mutexes are indicated with a stop sign.
- Sections (Windows file-mapping objects) are shown as memory chips.
- Events are shown as exclamation points.
- Semaphores are indicated with an icon that resembles a traffic signal.
- Symbolic links have icons that are curved arrows.
- Folders indicate object directories.
- Power/network plugs represent ALPC ports.
- Timers are shown as Clocks.
- Other icons such as various types of gears, locks, and chips are used for other object types.

Now use the **Extras** menu and select **Private Namespaces**. You'll see a list, such as the one shown here:

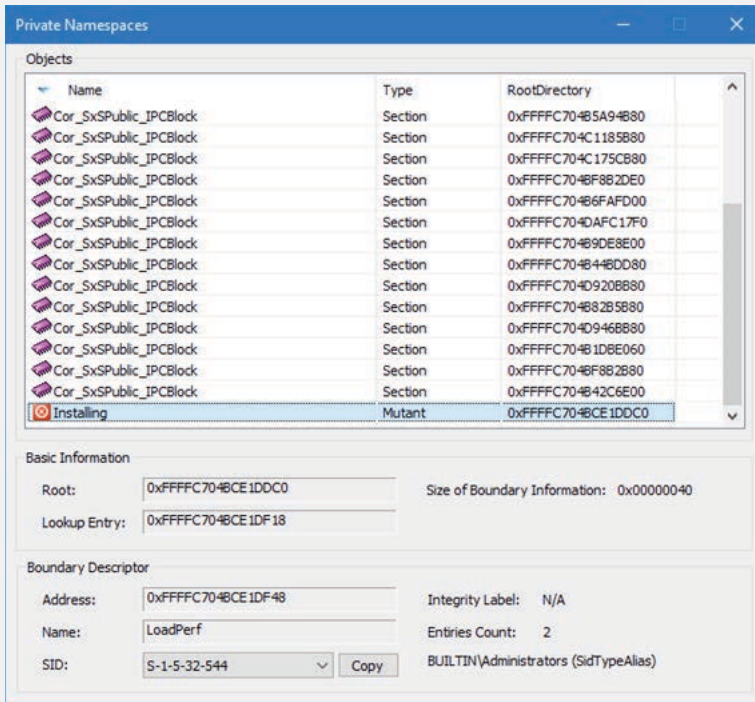

For each object, you'll see the name of the boundary descriptor (for example, the Installing mutex is part of the LoadPerf boundary), and the SID(s) and integrity level associated with it (in this case, no explicit integrity is set, and the SID is the one for the Administrators group). Note that for this feature to work, you must have enabled kernel debugging on the machine the tool is running on (either locally or remotely), as WinObjEx64 uses the WinDbg local kernel debugging driver to read kernel memory.

EXPERIMENT: Tampering with single instancing

Applications such as Windows Media Player and those in Microsoft Office are common examples of single-instancing enforcement through named objects. Notice that when launching the `Wmplayer.exe` executable, Windows Media Player appears only once—every other launch simply results in the window coming back into focus. You can tamper with the handle list by using Process Explorer to turn the computer into a media mixer! Here's how:

1. Launch Windows Media Player and Process Explorer to view the handle table (by clicking View, Lower Pane View, and then Handles). You should see a handle whose name contains `Microsoft_WMP_70_CheckForOtherInstanceMutex`, as shown in the figure.

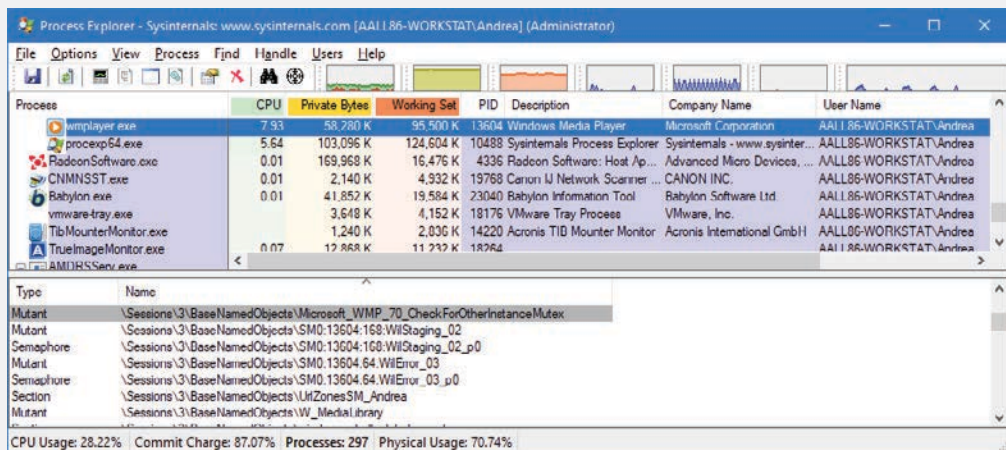

2. Right-click the handle and select **Close Handle**. Confirm the action when asked. Note that Process Explorer should be started as Administrator to be able to close a handle in another process.
3. Run Windows Media Player again. Notice that this time a second process is created.
4. Go ahead and play a different song in each instance. You can also use the Sound Mixer in the system tray (click the **Volume** icon) to select which of the two processes will have greater volume, effectively creating a mixing environment.

Instead of closing a handle to a named object, an application could have run on its own before Windows Media Player and created an object with the same name. In this scenario, Windows Media Player would never run because it would be fooled into believing it was already running on the system.

Symbolic links

In certain file systems (on NTFS, Linux, and macOS systems, for example), a symbolic link lets a user create a file name or a directory name that, when used, is translated by the operating system into a different file or directory name. Using a symbolic link is a simple method for allowing users to indirectly share a file or the contents of a directory, creating a cross-link between different directories in the ordinarily hierarchical directory structure.

The Object Manager implements an object called a *symbolic link object*, which performs a similar function for object names in its object namespace. A symbolic link can occur anywhere within an object name string. When a caller refers to a symbolic link object's name, the Object Manager traverses its object namespace until it reaches the symbolic link object. It looks inside the symbolic link and finds a string that it substitutes for the symbolic link name. It then restarts its name lookup.

One place in which the executive uses symbolic link objects is in translating MS-DOS-style device names into Windows internal device names. In Windows, a user refers to hard disk drives using the names C:, D:, and so on, and serial ports as COM1, COM2, and so on. The Windows subsystem creates these symbolic link objects and places them in the Object Manager namespace under the \Global?? directory, which can also be done for additional drive letters through the *DefineDosDevice* API.

In some cases, the underlying target of the symbolic link is not static and may depend on the caller's context. For example, older versions of Windows had an event in the \KernelObjects directory called *LowMemoryCondition*, but due to the introduction of memory partitions (described in Chapter 5 of Part 1), the condition that the event signals are now dependent on which partition the caller is running in (and should have visibility of). As such, there is now a *LowMemoryCondition* event for each memory partition, and callers must be redirected to the correct event for their partition. This is achieved with a special flag on the object, the lack of a target string, and the existence of a symbolic link callback executed each time the link is parsed by the Object Manager. With WinObjEx64, you can see the registered callback, as shown in the screenshot in Figure 8-36 (you could also use the debugger by doing a **!object \KernelObjects\LowMemoryCondition** command and then dumping the `_OBJECT_SYMBOLIC_LINK` structure with the **dx** command.)

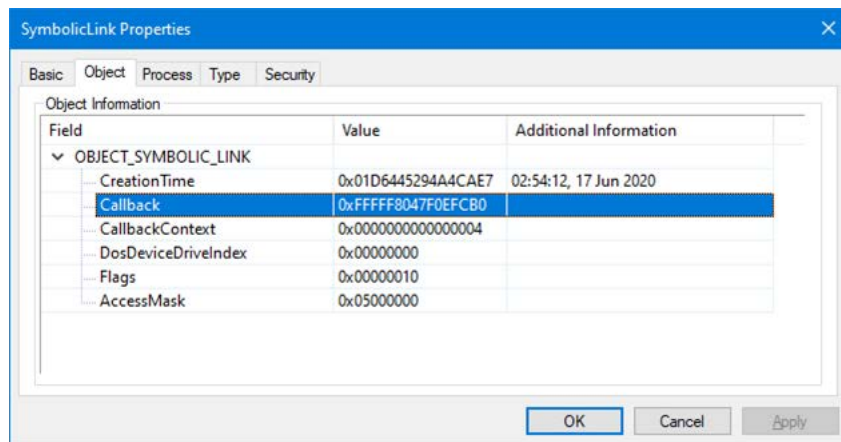

FIGURE 8-36 The LowMemoryCondition symbolic link redirection callback.

Session namespace

Services have full access to the *global* namespace, a namespace that serves as the first instance of the namespace. Regular user applications then have read-write (but not delete) access to the global namespace (minus some exceptions we explain soon.) In turn, however, interactive user sessions are then given a session-private view of the namespace known as a *local* namespace. This namespace provides full read/write access to the base named objects by all applications running within that session and is also used to isolate certain Windows subsystem-specific objects, which are still privileged. The parts of the namespace that are localized for each session include `\DosDevices`, `\Windows`, `\BaseNamedObjects`, and `\AppContainerNamedObjects`.

Making separate copies of the same parts of the namespace is known as *instanting* the namespace. Instanting `\DosDevices` makes it possible for each user to have different network drive letters and Windows objects such as serial ports. On Windows, the global `\DosDevices` directory is named `\Global??` and is the directory to which `\DosDevices` points, and local `\DosDevices` directories are identified by the logon session ID.

The `\Windows` directory is where `Win32k.sys` inserts the interactive window station created by `Winlogon`, `\WinSta0`. A Terminal Services environment can support multiple interactive users, but each user needs an individual version of `WinSta0` to preserve the illusion that he is accessing the predefined interactive window station in Windows. Finally, regular Win32 applications and the system create shared objects in `\BaseNamedObjects`, including events, mutexes, and memory sections. If two users are running an application that creates a named object, each user session must have a private version of the object so that the two instances of the application don't interfere with one another by accessing the same object. If the Win32 application is running under an `AppContainer`, however, or is a UWP application, then the sandboxing mechanisms prevent it from accessing `\BaseNamedObjects`, and the `\AppContainerNamedObjects` object directory is used instead, which then has further subdirectories whose names correspond to the Package SID of the `AppContainer` (see Chapter 7 of Part 1, for more information on `AppContainer` and the Windows sandboxing model).

The Object Manager implements a local namespace by creating the private versions of the four directories mentioned under a directory associated with the user's session under `\Sessions\n` (where *n* is the session identifier). When a Windows application in remote session two creates a named event, for example, the Win32 subsystem (as part of the `BaseGetNamedObjectDirectory` API in `Kernelbase.dll`) transparently redirects the object's name from `\BaseNamedObjects` to `\Sessions\n\BaseNamedObjects`, or, in the case of an `AppContainer`, to `\Sessions\n\AppContainerNamedObjects\<PackageSID>`.

One more way through which name objects can be accessed is through a security feature called Base Named Object (BNO) Isolation. Parent processes can launch a child with the `ProcThreadAttribute BnoIsolation` process attribute (see Chapter 3 of Part 1 for more information on a process's startup attributes), supplying a custom object directory prefix. In turn, this makes `KernelBase.dll` create the directory and initial set of objects (such as symbolic links) to support it, and then have `NtCreateUserProcess` set the prefix (and related initial handles) in the Token object of the child process (specifically, in the `BnoIsolationHandlesEntry` field) through the data in the native version of process attribute.

Later, *BaseGetNamedObjectDirectory* queries the Token object to check if BNO Isolation is enabled, and if so, it appends this prefix to any named object operation, such that `\Sessions\2\BaseNamedObjects` will, for example, become `\Sessions\2\BaseNamedObjects\IsolationExample`. This can be used to create a sort of sandbox for a process without having to use the AppContainer functionality.

All object-manager functions related to namespace management are aware of the instanced directories and participate in providing the illusion that all sessions use the same namespace. Windows subsystem DLLs prefix names passed by Windows applications that reference objects in the `\DosDevices` directory with `\??` (for example, `C:\Windows` becomes `\??\C:\Windows`). When the Object Manager sees the special `\??` prefix, the steps it takes depend on the version of Windows, but it always relies on a field named *DeviceMap* in the executive process object (EPROCESS, which is described further in Chapter 3 of Part 1) that points to a data structure shared by other processes in the same session.

The *DosDevicesDirectory* field of the *DeviceMap* structure points at the Object Manager directory that represents the process' local `\DosDevices`. When the Object Manager sees a reference to `\??`, it locates the process' local `\DosDevices` by using the *DosDevicesDirectory* field of the *DeviceMap*. If the Object Manager doesn't find the object in that directory, it checks the *DeviceMap* field of the directory object. If it's valid, it looks for the object in the directory pointed to by the *GlobalDosDevicesDirectory* field of the *DeviceMap* structure, which is always `\Global??`.

Under certain circumstances, session-aware applications need to access objects in the global session even if the application is running in another session. The application might want to do this to synchronize with instances of itself running in other remote sessions or with the console session (that is, session 0). For these cases, the Object Manager provides the special override `\Global` that an application can prefix to any object name to access the global namespace. For example, an application in session two opening an object named `\Global\ApplicationInitialized` is directed to `\BaseNamedObjects\ApplicationInitialized` instead of `\Sessions\2\BaseNamedObjects\ApplicationInitialized`.

An application that wants to access an object in the global `\DosDevices` directory does not need to use the `\Global` prefix as long as the object doesn't exist in its local `\DosDevices` directory. This is because the Object Manager automatically looks in the global directory for the object if it doesn't find it in the local directory. However, an application can force checking the global directory by using `\GLOBALROOT`.

Session directories are isolated from each other, but as mentioned earlier, regular user applications can create a global object with the `\Global` prefix. However, an important security mitigation exists: Section and symbolic link objects cannot be globally created unless the caller is running in Session 0 or if the caller possesses a special privilege named *create global object*, unless the object's name is part of an authorized list of "unsecured names," which is stored in `HKLM\SYSTEM\CurrentControlSet\Control\Session Manager\kernel`, under the *ObUnsecureGlobalNames* value. By default, these names are usually listed:

- `netfxcustomperfcounters.1.0`
- `SharedPerfIPCBLOCK`
- `Cor_Private_IPCBLOCK`
- `Cor_Public_IPCBLOCK_`

EXPERIMENT: Viewing namespace instancing

You can see the separation between the session 0 namespace and other session namespaces as soon as you log in. The reason you can is that the first console user is logged in to session 1 (while services run in session 0). Run Winobj.exe as Administrator and click the \Sessions directory. You'll see a subdirectory with a numeric name for each active session. If you open one of these directories, you'll see subdirectories named DosDevices, Windows, AppContainerNamedObjects, and BaseNamedObjects, which are the local namespace subdirectories of the session. The following figure shows a local namespace:

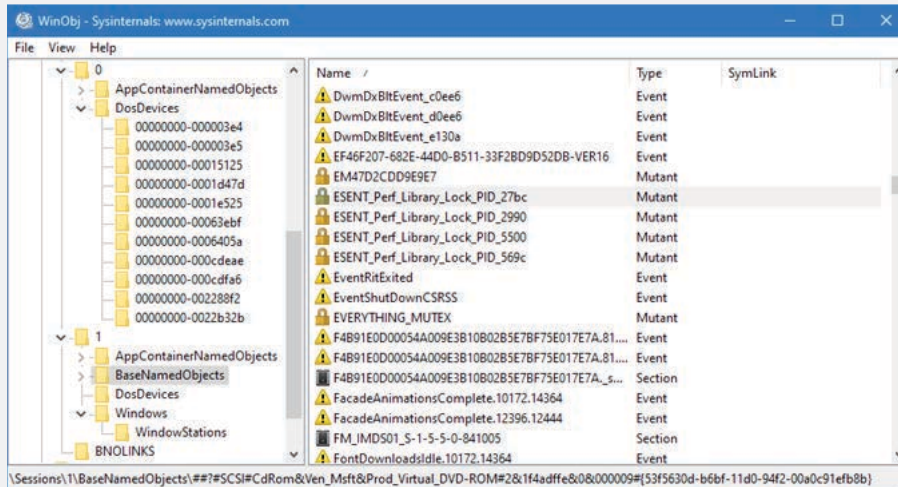

Next, run Process Explorer and select a process in your session (such as Explorer.exe), and then view the handle table (by clicking **View, Lower Pane View**, and then **Handles**). You should see a handle to \Windows\WindowStations\WinSta0 underneath \Sessions\1, where *n* is the session ID.

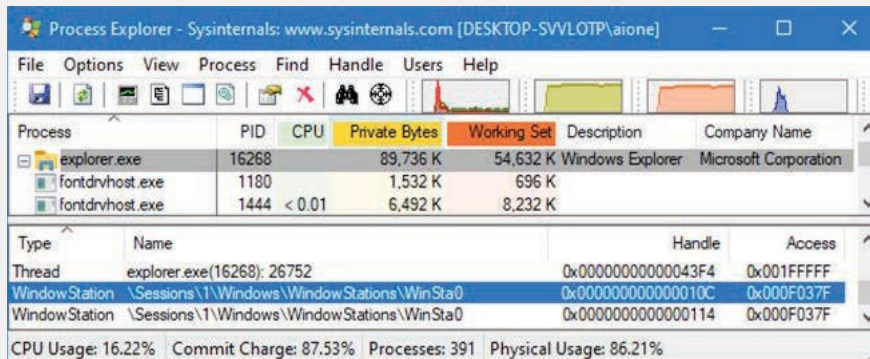

Object filtering

Windows includes a filtering model in the Object Manager, akin to the file system minifilter model and the registry callbacks mentioned in Chapter 10. One of the primary benefits of this filtering model is the ability to use the *altitude* concept that these existing filtering technologies use, which means that multiple drivers can filter Object Manager events at appropriate locations in the filtering stack. Additionally, drivers are permitted to intercept calls such as *NtOpenThread* and *NtOpenProcess* and even to modify the access masks being requested from the process manager. This allows protection against certain operations on an open handle—such as preventing a piece of malware from terminating a benevolent security process or stopping a password dumping application from obtaining read memory permissions on the LSA process. Note, however, that an open operation cannot be entirely blocked due to compatibility issues, such as making Task Manager unable to query the command line or image name of a process.

Furthermore, drivers can take advantage of both *pre* and *post* callbacks, allowing them to prepare for a certain operation before it occurs, as well as to react or finalize information after the operation has occurred. These callbacks can be specified for each operation (currently, only open, create, and duplicate are supported) and be specific for each object type (currently, only process, thread, and desktop objects are supported). For each callback, drivers can specify their own internal context value, which can be returned across all calls to the driver or across a pre/post pair. These callbacks can be registered with the *ObRegisterCallbacks* API and unregistered with the *ObUnregisterCallbacks* API—it is the responsibility of the driver to ensure deregistration happens.

Use of the APIs is restricted to images that have certain characteristics:

- The image must be signed, even on 32-bit computers, according to the same rules set forth in the Kernel Mode Code Signing (KMCS) policy. The image must be compiled with the */integrity-check* linker flag, which sets the *IMAGE_DLLCHARACTERISTICS_FORCE_INTEGRITY* value in the PE header. This instructs the memory manager to check the signature of the image regardless of any other defaults that might not normally result in a check.
- The image must be signed with a catalog containing cryptographic per-page hashes of the executable code. This allows the system to detect changes to the image after it has been loaded in memory.

Before executing a callback, the Object Manager calls the *MmVerifyCallbackFunction* on the target function pointer, which in turn locates the loader data table entry associated with the module owning this address and verifies whether the *LDRP_IMAGE_INTEGRITY_FORCED* flag is set.

Synchronization

The concept of *mutual exclusion* is a crucial one in operating systems development. It refers to the guarantee that one, and only one, thread can access a particular resource at a time. Mutual exclusion is necessary when a resource doesn't lend itself to shared access or when sharing would result in an unpredictable outcome. For example, if two threads copy a file to a printer port at the same time, their output could be interspersed. Similarly, if one thread reads a memory location while another one writes to it, the first thread will receive unpredictable data. In general, writable resources can't be shared without restrictions,

whereas resources that aren't subject to modification can be shared. Figure 8-37 illustrates what happens when two threads running on different processors both write data to a circular queue.

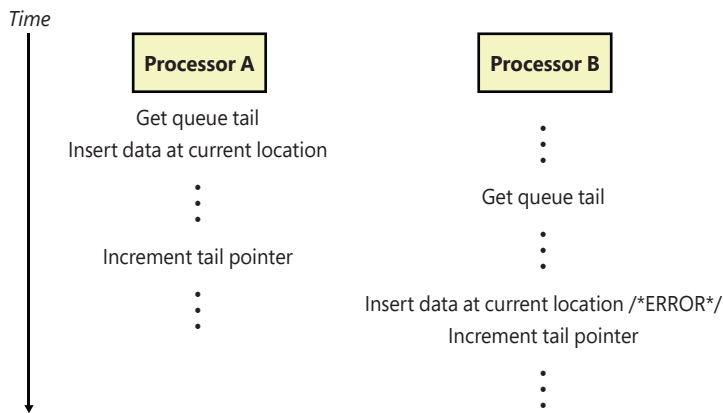

FIGURE 8-37 Incorrect sharing of memory.

Because the second thread obtained the value of the queue tail pointer before the first thread finished updating it, the second thread inserted its data into the same location that the first thread used, overwriting data and leaving one queue location empty. Even though Figure 8-37 illustrates what could happen on a multiprocessor system, the same error could occur on a single-processor system if the operating system performed a context switch to the second thread before the first thread updated the queue tail pointer.

Sections of code that access a nonshareable resource are called *critical sections*. To ensure correct code, only one thread at a time can execute in a critical section. While one thread is writing to a file, updating a database, or modifying a shared variable, no other thread can be allowed to access the same resource. The pseudocode shown in Figure 8-37 is a critical section that incorrectly accesses a shared data structure without mutual exclusion.

The issue of mutual exclusion, although important for all operating systems, is especially important (and intricate) for a *tightly coupled, symmetric multiprocessing (SMP)* operating system such as Windows, in which the same system code runs simultaneously on more than one processor, sharing certain data structures stored in global memory. In Windows, it is the kernel's job to provide mechanisms that system code can use to prevent two threads from modifying the same data at the same time. The kernel provides mutual-exclusion primitives that it and the rest of the executive use to synchronize their access to global data structures.

Because the scheduler synchronizes access to its data structures at DPC/dispatch level IRQL, the kernel and executive cannot rely on synchronization mechanisms that would result in a page fault or reschedule operation to synchronize access to data structures when the IRQL is DPC/dispatch level or higher (levels known as an *elevated* or *high* IRQL). In the following sections, you'll find out how the kernel and executive use mutual exclusion to protect their global data structures when the IRQL is high and what mutual-exclusion and synchronization mechanisms the kernel and executive use when the IRQL is *low* (below DPC/dispatch level).

High-IRQL synchronization

At various stages during its execution, the kernel must guarantee that one, and only one, processor at a time is executing within a critical section. Kernel critical sections are the code segments that modify a global data structure such as the kernel's dispatcher database or its DPC queue. The operating system can't function correctly unless the kernel can guarantee that threads access these data structures in a mutually exclusive manner.

The biggest area of concern is interrupts. For example, the kernel might be updating a global data structure when an interrupt occurs whose interrupt-handling routine also modifies the structure. Simple single-processor operating systems sometimes prevent such a scenario by disabling all interrupts each time they access global data, but the Windows kernel has a more sophisticated solution. Before using a global resource, the kernel temporarily masks the interrupts whose interrupt handlers also use the resource. It does so by raising the processor's IRQL to the highest level used by any potential interrupt source that accesses the global data. For example, an interrupt at DPC/dispatch level causes the dispatcher, which uses the dispatcher database, to run. Therefore, any other part of the kernel that uses the dispatcher database raises the IRQL to DPC/dispatch level, masking DPC/dispatch-level interrupts before using the dispatcher database.

This strategy is fine for a single-processor system, but it's inadequate for a multiprocessor configuration. Raising the IRQL on one processor doesn't prevent an interrupt from occurring on another processor. The kernel also needs to guarantee mutually exclusive access across several processors.

Interlocked operations

The simplest form of synchronization mechanisms relies on hardware support for multiprocessor-safe manipulation of integer values and for performing comparisons. They include functions such as *InterlockedIncrement*, *InterlockedDecrement*, *InterlockedExchange*, and *InterlockedCompareExchange*. The *InterlockedDecrement* function, for example, uses the x86 and x64 *lock* instruction prefix (for example, *lock xadd*) to lock the multiprocessor bus during the addition operation so that another processor that's also modifying the memory location being decremented won't be able to modify it between the decrementing processor's read of the original value and its write of the decremented value. This form of basic synchronization is used by the kernel and drivers. In today's Microsoft compiler suite, these functions are called *intrinsic* because the code for them is generated in an inline assembler, directly during the compilation phase, instead of going through a function call (it's likely that pushing the parameters onto the stack, calling the function, copying the parameters into registers, and then popping the parameters off the stack and returning to the caller would be a more expensive operation than the actual work the function is supposed to do in the first place.)

Spinlocks

The mechanism the kernel uses to achieve multiprocessor mutual exclusion is called a *spinlock*. A spinlock is a locking primitive associated with a global data structure, such as the DPC queue shown in Figure 8-38.

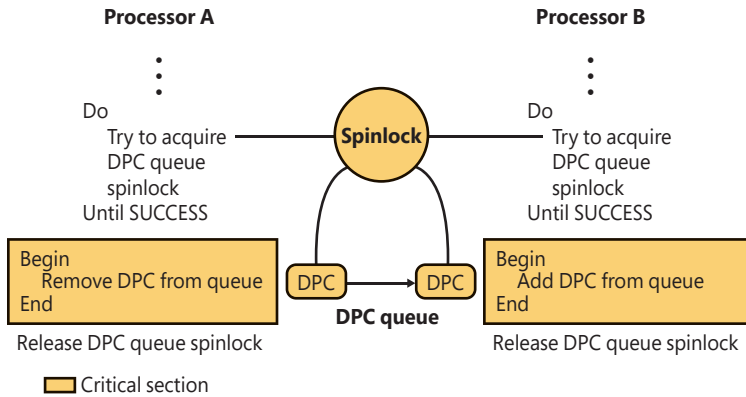

FIGURE 8-38 Using a spinlock.

Before entering either critical section shown in Figure 8-38, the kernel must acquire the spinlock associated with the protected DPC queue. If the spinlock isn't free, the kernel keeps trying to acquire the lock until it succeeds. The spinlock gets its name from the fact that the kernel (and thus, the processor) waits, "spinning," until it gets the lock.

Spinlocks, like the data structures they protect, reside in nonpaged memory mapped into the system address space. The code to acquire and release a spinlock is written in assembly language for speed and to exploit whatever locking mechanism the underlying processor architecture provides. On many architectures, spinlocks are implemented with a hardware-supported test-and-set operation, which tests the value of a lock variable and acquires the lock in one atomic instruction. Testing and acquiring the lock in one instruction prevents a second thread from grabbing the lock between the time the first thread tests the variable and the time it acquires the lock. Additionally, a hardware instruction such as the *lock* instruction mentioned earlier can also be used on the test-and-set operation, resulting in the combined *lock bts* opcode on x86 and x64 processors, which also locks the multiprocessor bus; otherwise, it would be possible for more than one processor to perform the operation atomically. (Without the *lock*, the operation is guaranteed to be atomic only on the current processor.) Similarly, on ARM processors, instructions such as *ldrex* and *strex* can be used in a similar fashion.

All kernel-mode spinlocks in Windows have an associated IRQL that is always DPC/dispatch level or higher. Thus, when a thread is trying to acquire a spinlock, all other activity at the spinlock's IRQL or lower ceases on that processor. Because thread dispatching happens at DPC/dispatch level, a thread that holds a spinlock is never preempted because the IRQL masks the dispatching mechanisms. This masking allows code executing in a critical section protected by a spinlock to continue executing so that it will release the lock quickly. The kernel uses spinlocks with great care, minimizing the number of instructions it executes while it holds a spinlock. Any processor that attempts to acquire the spinlock will essentially be busy, waiting indefinitely, consuming power (a busy wait results in 100% CPU usage) and performing no actual work.

On x86 and x64 processors, a special *pause* assembly instruction can be inserted in busy wait loops, and on ARM processors, *yield* provides a similar benefit. This instruction offers a *hint* to the processor that the loop instructions it is processing are part of a spinlock (or a similar construct) acquisition loop. The instruction provides three benefits:

- It significantly reduces power usage by delaying the core ever so slightly instead of continuously looping.
- On SMT cores, it allows the CPU to realize that the “work” being done by the spinning logical core is not terribly important and awards more CPU time to the second logical core instead.
- Because a busy wait loop results in a storm of read requests coming to the bus from the waiting thread (which might be generated out of order), the CPU attempts to correct for violations of memory order as soon as it detects a write (that is, when the owning thread releases the lock). Thus, as soon as the spinlock is released, the CPU reorders any pending memory read operations to ensure proper ordering. This reordering results in a large penalty in system performance and can be avoided with the *pause* instruction.

If the kernel detects that it is running under a Hyper-V compatible hypervisor, which supports the spinlock enlightenment (described in Chapter 9), the spinlock facility can use the *HvINotifyLongSpinWait* library function when it detects that the spinlock is currently owned by another CPU, instead of contiguously spinning and use the *pause* instruction. The function emits a *HvCallNotifyLongSpinWait* hypercall to indicate to the hypervisor scheduler that another VP should take over instead of emulating the spin.

The kernel makes spinlocks available to other parts of the executive through a set of kernel functions, including *KeAcquireSpinLock* and *KeReleaseSpinLock*. Device drivers, for example, require spinlocks to guarantee that device registers and other global data structures are accessed by only one part of a device driver (and from only one processor) at a time. Spinlocks are not for use by user programs—user programs should use the objects described in the next section. Device drivers also need to protect access to their own data structures from interrupts associated with themselves. Because the spinlock APIs typically raise the IRQL only to DPC/dispatch level, this isn’t enough to protect against interrupts. For this reason, the kernel also exports the *KeAcquireInterruptSpinLock* and *KeReleaseInterruptSpinLock* APIs that take as a parameter the KINTERRUPT object discussed at the beginning of this chapter. The system looks inside the interrupt object for the associated DIRQL with the interrupt and raises the IRQL to the appropriate level to ensure correct access to structures shared with the ISR.

Devices can also use the *KeSynchronizeExecution* API to synchronize an entire function with an ISR instead of just a critical section. In all cases, the code protected by an interrupt spinlock must execute extremely quickly—any delay causes higher-than-normal interrupt latency and will have significant negative performance effects.

Kernel spinlocks carry with them restrictions for code that uses them. Because spinlocks always have an IRQL of DPC/dispatch level or higher, as explained earlier, code holding a spinlock will crash the system if it attempts to make the scheduler perform a dispatch operation or if it causes a page fault.

Queued spinlocks

To increase the scalability of spinlocks, a special type of spinlock, called a *queued spinlock*, is used in many circumstances instead of a standard spinlock, especially when contention is expected, and fairness is required.

A queued spinlock works like this: When a processor wants to acquire a queued spinlock that is currently held, it places its identifier in a queue associated with the spinlock. When the processor that's holding the spinlock releases it, it hands the lock over to the next processor identified in the queue. In the meantime, a processor waiting for a busy spinlock checks the status not of the spinlock itself but of a per-processor flag that the processor ahead of it in the queue sets to indicate that the waiting processor's turn has arrived.

The fact that queued spinlocks result in spinning on per-processor flags rather than global spinlocks has two effects. The first is that the multiprocessor's bus isn't as heavily trafficked by interprocessor synchronization, and the memory location of the bit is not in a single NUMA node that then has to be snooped through the caches of each logical processor. The second is that instead of a random processor in a waiting group acquiring a spinlock, the queued spinlock enforces first-in, first-out (FIFO) ordering to the lock. FIFO ordering means more consistent performance (fairness) across processors accessing the same locks. While the reduction in bus traffic and increase in fairness are great benefits, queued spinlocks do require additional overhead, including extra interlocked operations, which do add their own costs. Developers must carefully balance the management overhead with the benefits to decide if a queued spinlock is worth it for them.

Windows uses two different types of queued spinlocks. The first are internal to the kernel only, while the second are available to external and third-party drivers as well. First, Windows defines a number of *global* queued spinlocks by storing pointers to them in an array contained in each processor's *processor control region* (PCR). For example, on x64 systems, these are stored in the *LockArray* field of the *KPCR* data structure.

A global spinlock can be acquired by calling *KeAcquireQueuedSpinLock* with the index into the array at which the pointer to the spinlock is stored. The number of global spinlocks originally grew in each release of the operating system, but over time, more efficient locking hierarchies were used that do not require global per-processor locking. You can view the table of index definitions for these locks in the WDK header file *Wdm.h* under the *KSPIN_LOCK_QUEUE_NUMBER* enumeration, but note, however, that acquiring one of these queued spinlocks from a device driver is an unsupported and heavily frowned-upon operation. As we said, these locks are reserved for the kernel's internal use.

EXPERIMENT: Viewing global queued spinlocks

You can view the state of the global queued spinlocks (the ones pointed to by the queued spinlock array in each processor's PCR) by using the **!qllocks** kernel debugger command. In the following example, note that none of the locks are acquired on any of the processors, which is a standard situation on a local system doing live debugging.

```
!kd> !qllocks
```

```
Key: 0 = Owner, 1-n = Wait order, blank = not owned/waiting, C = Corrupt
```

Lock Name	Processor Number							
	0	1	2	3	4	5	6	7
KE	-							
MM	-							
MM	-							
MM	-							
CC	-							
CC	-							
EX	-							
IO	-							
CC	-							

In-stack queued spinlocks

Device drivers can use dynamically allocated queued spinlocks with the *KeAcquireInStackQueuedSpinLock* and *KeReleaseInStackQueuedSpinLock* functions. Several components—including the cache manager, executive pool manager, and NTFS—take advantage of these types of locks instead of using global queued spinlocks.

KeAcquireInStackQueuedSpinLock takes a pointer to a spinlock data structure and a spinlock queue handle. The spinlock queue handle is actually a data structure in which the kernel stores information about the lock's status, including the lock's ownership and the queue of processors that might be waiting for the lock to become available. For this reason, the handle shouldn't be a global variable. It is usually a stack variable, guaranteeing *locality* to the caller thread and is responsible for the *InStack* part of the spinlock and API name.

Reader/writer spin locks

While using queued spinlocks greatly improves latency in highly contended situations, Windows supports another kind of spinlock that can offer even greater benefits by potentially eliminating contention in many situations to begin with. The multi-reader, single-writer spinlock, also called the *executive spinlock*, is an enhancement on top of regular spinlocks, which is exposed through the *ExAcquireSpinLockExclusive*, *ExAcquireSpinLockShared* API, and their *ExReleaseXxx* counterparts. Additionally, *ExTryAcquireSpinLockSharedAtDpcLevel* and *ExTryConvertSharedSpinLockToExclusive* functions exist for more advanced use cases.

As the name suggests, this type of lock allows noncontended shared acquisition of a spinlock if no writer is present. When a writer is interested in the lock, readers must eventually release the lock, and no further readers will be allowed while the writer is active (nor additional writers). If a driver developer often finds themselves iterating over a linked list, for example, while only rarely inserting or removing items, this type of lock can remove contention in the majority of cases, removing the need for the complexity of a queued spinlock.

Executive interlocked operations

The kernel supplies some simple synchronization functions constructed on spinlocks for more advanced operations, such as adding and removing entries from singly and doubly linked lists. Examples include *ExInterlockedPopEntryList* and *ExInterlockedPushEntryList* for singly linked lists, and *ExInterlockedInsertHeadList* and *ExInterlockedRemoveHeadList* for doubly linked lists. A few other functions, such as *ExInterlockedAddUlong* and *ExInterlockedAddLargeInteger* also exist. All these functions require a standard spinlock as a parameter and are used throughout the kernel and device drivers' code.

Instead of relying on the standard APIs to acquire and release the spinlock parameter, these functions place the code required inline and also use a different ordering scheme. Whereas the *Ke* spinlock APIs first test and set the bit to see whether the lock is released and then atomically perform a locked test-and-set operation to make the acquisition, these routines disable interrupts on the processor and immediately attempt an atomic test-and-set. If the initial attempt fails, interrupts are enabled again, and the standard busy waiting algorithm continues until the test-and-set operation returns 0—in which case the whole function is restarted again. Because of these subtle differences, a spinlock used for the executive interlocked functions must not be used with the standard kernel APIs discussed previously. Naturally, noninterlocked list operations must not be mixed with interlocked operations.



Note Certain executive interlocked operations silently ignore the spinlock when possible. For example, the *ExInterlockedIncrementLong* or *ExInterlockedCompareExchange* APIs use the same *lock* prefix used by the standard interlocked functions and the intrinsic functions. These functions were useful on older systems (or non-x86 systems) where the *lock* operation was not suitable or available. For this reason, these calls are now deprecated and are silently inlined in favor of the intrinsic functions.

Low-IRQL synchronization

Executive software outside the kernel also needs to synchronize access to global data structures in a multiprocessor environment. For example, the memory manager has only one page frame database, which it accesses as a global data structure, and device drivers need to ensure that they can gain exclusive access to their devices. By calling kernel functions, the executive can create a spinlock, acquire it, and release it.

Spinlocks only partially fill the executive's needs for synchronization mechanisms, however. Because waiting for a spinlock literally stalls a processor, spinlocks can be used only under the following strictly limited circumstances:

- The protected resource must be accessed quickly and without complicated interactions with other code.
- The critical section code can't be paged out of memory, can't make references to pageable data, can't call external procedures (including system services), and can't generate interrupts or exceptions.

These restrictions are confining and can't be met under all circumstances. Furthermore, the executive needs to perform other types of synchronization in addition to mutual exclusion, and it must also provide synchronization mechanisms to user mode.

There are several additional synchronization mechanisms for use when spinlocks are not suitable:

- Kernel dispatcher objects (mutexes, semaphores, events, and timers)
- Fast mutexes and guarded mutexes
- Pushlocks
- Executive resources
- Run-once initialization (InitOnce)

Additionally, user-mode code, which also executes at low IRQL, must be able to have its own locking primitives. Windows supports various user-mode-specific primitives:

- System calls that refer to kernel dispatcher objects (mutants, semaphores, events, and timers)
- Condition variables (CondVars)
- Slim Reader-Writer Locks (SRW Locks)
- Address-based waiting
- Run-once initialization (InitOnce)
- Critical sections

We look at the user-mode primitives and their underlying kernel-mode support later; for now, we focus on kernel-mode objects. Table 8-26 compares and contrasts the capabilities of these mechanisms and their interaction with kernel-mode APC delivery.

TABLE 8-26 Kernel synchronization mechanisms

	Exposed for Use by Device Drivers	Disables Normal Kernel-Mode APCs	Disables Special Kernel-Mode APCs	Supports Recursive Acquisition	Supports Shared and Exclusive Acquisition
Kernel dispatcher mutexes	Yes	Yes	No	Yes	No
Kernel dispatcher semaphores, events, timers	Yes	No	No	No	No
Fast mutexes	Yes	Yes	Yes	No	No
Guarded mutexes	Yes	Yes	Yes	No	No
Pushlocks	Yes	No	No	No	Yes
Executive resources	Yes	No	No	Yes	Yes
Rundown protections	Yes	No	No	Yes	No

Kernel dispatcher objects

The kernel furnishes additional synchronization mechanisms to the executive in the form of kernel objects, known collectively as *dispatcher objects*. The Windows API-visible synchronization objects acquire their synchronization capabilities from these kernel dispatcher objects. Each Windows API-visible object that supports synchronization encapsulates at least one kernel dispatcher object. The executive's synchronization semantics are visible to Windows programmers through the *WaitForSingleObject* and *WaitForMultipleObjects* functions, which the Windows subsystem implements by calling analogous system services that the Object Manager supplies. A thread in a Windows application can synchronize with a variety of objects, including a Windows process, thread, event, semaphore, mutex, waitable timer, I/O completion port, ALPC port, registry key, or file object. In fact, almost all objects exposed by the kernel can be waited on. Some of these are proper dispatcher objects, whereas others are larger objects that have a dispatcher object within them (such as ports, keys, or files). Table 8-27 (later in this chapter in the section "What signals an object?") shows the proper dispatcher objects, so any other object that the Windows API allows waiting on probably internally contains one of those primitives.

Two other types of executive synchronization mechanisms worth noting are the *executive resource* and the *pushlock*. These mechanisms provide exclusive access (like a mutex) as well as shared read access (multiple readers sharing read-only access to a structure). However, they're available only to kernel-mode code and thus are not accessible from the Windows API. They're also not true objects—they have an API exposed through raw pointers and *Ex* APIs, and the Object Manager and its handle system are not involved. The remaining subsections describe the implementation details of waiting for dispatcher objects.

Waiting for dispatcher objects

The traditional way that a thread can synchronize with a dispatcher object is by waiting for the object's handle, or, for certain types of objects, directly waiting on the object's pointer. The *NtWaitForXxx* class of APIs (which is also what's exposed to user mode) works with handles, whereas the *KeWaitForXxx* APIs deal directly with the dispatcher object.

Because the *Nt* API communicates with the Object Manager (*ObWaitForXxx* class of functions), it goes through the abstractions that were explained in the section on object types earlier in this chapter. For example, the *Nt* API allows passing in a handle to a File Object, because the Object Manager uses the information in the object type to redirect the wait to the *Event* field inside of *FILE_OBJECT*. The *Ke* API, on the other hand, only works with true dispatcher objects—that is to say, those that begin with a *DISPATCHER_HEADER* structure. Regardless of the approach taken, these calls ultimately cause the kernel to put the thread in a wait state.

A completely different, and more modern, approach to waiting on dispatcher objects is to rely on *asynchronous waiting*. This approach leverages the existing I/O completion port infrastructure to associate a dispatcher object with the kernel queue backing the I/O completion port, by going through an intermediate object called a *wait completion packet*. Thanks to this mechanism, a thread essentially *registers* a wait but does not directly block on the dispatcher object and does not enter a wait state. Instead, when the wait is satisfied, the I/O completion port will have the wait completion packet inserted, acting as a notification for anyone who is pulling items from, or waiting on, the I/O completion port. This allows one or more threads to register wait indications on various objects, which a separate thread (or pool of threads) can essentially wait on. As you've probably guessed, this mechanism is the linchpin of the Thread Pool API's functionality supporting wait callbacks, in APIs such as *CreateThreadPoolWait* and *SetThreadPoolWait*.

Finally, an extension of the asynchronous waiting mechanism was built into more recent builds of Windows 10, through the *DPC Wait Event* functionality that is currently reserved for Hyper-V (although the API is exported, it is not yet documented). This introduces a final approach to dispatcher waits, reserved for kernel-mode drivers, in which a *deferred procedure call* (DPC, explained earlier in this chapter) can be associated with a dispatcher object, instead of a thread or I/O completion port. Similar to the mechanism described earlier, the DPC is *registered* with the object, and when the wait is satisfied, the DPC is then queued into the current processor's queue (as if the driver had now just called *KeInsertQueueDpc*). When the dispatcher lock is dropped and the IRQL returns below *DISPATCH_LEVEL*, the DPC executes on the current processor, which is the driver-supplied callback that can now react to the signal state of the object.

Irrespective of the waiting mechanism, the synchronization object(s) being waited on can be in one of two states: *signaled state* or *nonsignaled state*. A thread can't resume its execution until its wait is satisfied, a condition that occurs when the dispatcher object whose handle the thread is waiting for also undergoes a state change, from the nonsignaled state to the signaled state (when another thread sets an event object, for example).

To synchronize with an object, a thread calls one of the wait system services that the Object Manager supplies, passing a handle to the object it wants to synchronize with. The thread can wait for one or several objects and can also specify that its wait should be canceled if it hasn't ended within a certain amount of time. Whenever the kernel sets an object to the signaled state, one of the kernel's signal routines checks to see whether any threads are waiting for the object and not also waiting for other objects to become signaled. If there are, the kernel releases one or more of the threads from their waiting state so that they can continue executing.

To be asynchronously notified of an object becoming signaled, a thread creates an I/O completion port, and then calls *NtCreateWaitCompletionPacket* to create a wait completion packet object and receive a handle back to it. Then, it calls *NtAssociateWaitCompletionPacket*, passing in both the handle to the I/O completion port as well as the handle to the wait completion packet it just created, combined with a handle to the object it wants to be notified about. Whenever the kernel sets an object to the signaled state, the signal routines realize that no thread is currently waiting on the object, and instead check whether an I/O completion port has been associated with the wait. If so, it signals the queue object associated with the port, which causes any threads currently waiting on it to wake up and consume the wait completion packet (or, alternatively, the queue simply becomes signaled until a thread comes in and attempts to wait on it). Alternatively, if no I/O completion port has been associated with the wait, then a check is made to see whether a DPC is associated instead, in which case it will be queued on the current processor. This part handles the kernel-only DPC Wait Event mechanism described earlier.

The following example of setting an event illustrates how synchronization interacts with thread dispatching:

- A user-mode thread waits for an event object's handle.
- The kernel changes the thread's scheduling state to waiting and then adds the thread to a list of threads waiting for the event.
- Another thread sets the event.
- The kernel marches down the list of threads waiting for the event. If a thread's conditions for waiting are satisfied (see the following note), the kernel takes the thread out of the waiting state. If it is a variable-priority thread, the kernel might also boost its execution priority. (For details on thread scheduling, see Chapter 4 of Part 1.)



Note Some threads might be waiting for more than one object, so they continue waiting, unless they specified a *WaitAny* wait, which will wake them up as soon as one object (instead of all) is signaled.

What signals an object?

The signaled state is defined differently for different objects. A thread object is in the nonsignaled state during its lifetime and is set to the signaled state by the kernel when the thread terminates. Similarly, the kernel sets a process object to the signaled state when the process's last thread terminates. In contrast, the timer object, like an alarm, is set to "go off" at a certain time. When its time expires, the kernel sets the timer object to the signaled state.

When choosing a synchronization mechanism, a programmer must take into account the rules governing the behavior of different synchronization objects. Whether a thread's wait ends when an object is set to the signaled state varies with the type of object the thread is waiting for, as Table 8-27 illustrates.

TABLE 8-27 Definitions of the signaled state

Object Type	Set to Signaled State When	Effect on Waiting Threads
Process	Last thread terminates.	All are released.
Thread	Thread terminates.	All are released.
Event (notification type)	Thread sets the event.	All are released.
Event (synchronization type)	Thread sets the event.	One thread is released and might receive a boost; the event object is reset.
Gate (locking type)	Thread signals the gate.	First waiting thread is released and receives a boost.
Gate (signaling type)	Thread signals the type.	First waiting thread is released.
Keyed event	Thread sets event with a key.	Thread that's waiting for the key and which is of the same process as the signaler is released.
Semaphore	Semaphore count drops by 1.	One thread is released.
Timer (notification type)	Set time arrives or time interval expires.	All are released.
Timer (synchronization type)	Set time arrives or time interval expires.	One thread is released.
Mutex	Thread releases the mutex.	One thread is released and takes ownership of the mutex.
Queue	Item is placed on queue.	One thread is released.

When an object is set to the signaled state, waiting threads are generally released from their wait states immediately.

For example, a notification event object (called a *manual reset event* in the Windows API) is used to announce the occurrence of some event. When the event object is set to the signaled state, all threads waiting for the event are released. The exception is any thread that is waiting for more than one object at a time; such a thread might be required to continue waiting until additional objects reach the signaled state.

In contrast to an event object, a mutex object has ownership associated with it (unless it was acquired during a DPC). It is used to gain mutually exclusive access to a resource, and only one thread at a time can hold the mutex. When the mutex object becomes free, the kernel sets it to the signaled state and then selects one waiting thread to execute, while also inheriting any priority boost that had been applied. (See Chapter 4 of Part 1 for more information on priority boosting.) The thread selected by the kernel acquires the mutex object, and all other threads continue waiting.

A mutex object can also be abandoned, something that occurs when the thread currently owning it becomes terminated. When a thread terminates, the kernel enumerates all mutexes owned by the thread and sets them to the abandoned state, which, in terms of signaling logic, is treated as a signaled state in that ownership of the mutex is transferred to a waiting thread.

This brief discussion wasn't meant to enumerate all the reasons and applications for using the various executive objects but rather to list their basic functionality and synchronization behavior. For information on how to put these objects to use in Windows programs, see the Windows reference documentation on synchronization objects or Jeffrey Richter and Christophe Nasarre's book *Windows via C/C++* from Microsoft Press.

Object-less waiting (thread alerts)

While the ability to wait for, or be notified about, an object becoming signaled is extremely powerful, and the wide variety of dispatcher objects at programmers' disposal is rich, sometimes a much simpler approach is needed. One thread wants to wait for a specific *condition* to occur, and another thread needs to signal the occurrence of the *condition*. Although this can be achieved by tying an event to the *condition*, this requires resources (memory and handles, to name a couple), and acquisition and creation of resources can fail while also taking time and being complex. The Windows kernel provides two mechanisms for synchronization that are not tied to dispatcher objects:

- Thread alerts
- Thread alert by ID

Although their names are similar, the two mechanisms work in different ways. Let's look at how thread alerts work. First, the thread wishing to synchronize enters an *alertable* sleep by using *SleepEx* (ultimately resulting in *NtDelayExecutionThread*). A kernel thread could also choose to use *KeDelayExecutionThread*. We previously explained the concept of alertability earlier in the section on software interrupts and APCs. In this case, the thread can either specify a timeout value or make the sleep infinite. Secondly, the other side uses the *NtAlertThread* (or *KeAlertThread*) API to alert the thread, which causes the sleep to abort, returning the status code *STATUS_ALERTED*. For the sake of completeness, it's also worth noting that a thread can choose not to enter an alertable sleep state, but instead, at a later time of its choosing, call the *NtTestAlert* (or *KeTestAlertThread*) API. Finally, a thread could also avoid entering an alertable wait state by suspending itself instead (*NtSuspendThread* or *KeSuspendThread*). In this case, the other side can use *NtAlertResumeThread* to both alert the thread and then resume it.

Although this mechanism is elegant and simple, it does suffer from a few issues, beginning with the fact that there is no way to identify whether the alert was the one related to the wait—in other words, any other thread could've *also* alerted the waiting thread, which has no way of distinguishing between the alerts. Second, the alert API is not officially documented—meaning that while internal kernel and user services can leverage this mechanism, third-party developers are not meant to use alerts. Third, once a thread becomes alerted, any pending queued APCs also begin executing—such as user-mode APCs if these alert APIs are used by applications. And finally, *NtAlertThread* still requires opening a handle to the target thread—an operation that technically counts as acquiring a resource, an operation which can fail. Callers could theoretically open their handles ahead of time, guaranteeing that the alert will succeed, but that still does add the cost of a handle in the whole mechanism.

To respond to these issues, the Windows kernel received a more modern mechanism starting with Windows 8, which is the *alert by ID*. Although the system calls behind this mechanism—*NtAlertThreadByThreadId* and *NtWaitForAlertByThreadId*—are not documented, the Win32 user-mode wait API that we describe later *is*. These system calls are extremely simple and require *zero* resources,

using only the Thread ID as input. Of course, since without a handle, this could be a security issue, the one disadvantage to these APIs is that they can only be used to synchronize with threads within the current process.

Explaining the behavior of this mechanism is fairly obvious: first, the thread blocks with the *NtWaitForAlertByThreadId* API, passing in an optional timeout. This makes the thread enter a real wait, without alertability being a concern. In fact, in spite of the name, this type of wait is *non-alertable*, by design. Next, the other thread calls the *NtAlertThreadByThreadId* API, which causes the kernel to look up the Thread ID, make sure it belongs to the calling process, and then check whether the thread is indeed blocking on a call to *NtWaitForAlertByThreadId*. If the thread is in this state, it's simply woken up. This simple, elegant mechanism is the heart of a number of user-mode synchronization primitives later in this chapter and can be used to implement anything from barriers to more complex synchronization methods.

Data structures

Three data structures are key to tracking *who* is waiting, *how* they are waiting, *what* they are waiting for, and *which state* the entire wait operation is at. These three structures are the *dispatcher header*, the *wait block*, and the *wait status register*. The former two structures are publicly defined in the WDK include file *Wdm.h*, whereas the latter is not documented but is visible in public symbols with the type *KWAIT_STATUS_REGISTER* (and the *Flags* field corresponds to the *KWAIT_STATE* enumeration).

The *dispatcher header* is a packed structure because it needs to hold a lot of information in a fixed-size structure. (See the upcoming “EXPERIMENT: Looking at wait queues” section to see the definition of the dispatcher header data structure.) One of the main techniques used in its definition is to store mutually exclusive flags at the same memory location (offset) in the structure, which is called a *union* in programming theory. By using the *Type* field, the kernel knows which of these fields is relevant. For example, a mutex can be *Abandoned*, but a timer can be *Relative*. Similarly, a timer can be *Inserted* into the timer list, but debugging can only be *Active* for a process. Outside of these specific fields, the dispatcher header also contains information that's meaningful regardless of the dispatcher object: the *Signaled* state and the *Wait List Head* for the wait blocks associated with the object.

These *wait blocks* are what represents that a thread (or, in the case of asynchronous waiting, an I/O completion port) is tied to an object. Each thread that is in a wait state has an array of up to 64 wait blocks that represent the object(s) the thread is waiting for (including, potentially, a wait block pointing to the internal thread timer that's used to satisfy a timeout that the caller may have specified). Alternatively, if the *alert-by-ID* primitives are used, there is a single block with a special indication that this is not a dispatcher-based wait. The *Object* field is replaced by a *Hint* that is specified by the caller of *NtWaitForAlertByThreadId*. This array is maintained for two main purposes:

- When a thread terminates, all objects that it was waiting on must be dereferenced, and the wait blocks deleted and disconnected from the object(s).
- When a thread is awakened by one of the objects it's waiting on (that is, by becoming signaled and *satisfying the wait*), all the other objects it may have been waiting on must be dereferenced and the wait blocks deleted and disconnected.

Just like a thread has this array of all the objects it's waiting on, as we mentioned just a bit earlier, each dispatcher object also has a linked list of wait blocks tied to it. This list is kept so that when a dispatcher object is signaled, the kernel can quickly determine who is waiting on (or which I/O completion port is tied to) that object and apply the wait satisfaction logic we explain shortly.

Finally, because the *balance set manager* thread running on each CPU (see Chapter 5 of Part 1 for more information about the balance set manager) needs to analyze the time that each thread has been waiting for (to decide whether to page out the kernel stack), each PRCB has a list of eligible waiting threads that last ran on that processor. This reuses the *Ready List* field of the *KTHREAD* structure because a thread can't both be ready and waiting at the same time. Eligible threads must satisfy the following three conditions:

- The wait must have been issued with a wait mode of *UserMode* (*KernelMode* waits are assumed to be time-sensitive and not worth the cost of stack swapping).
- The thread must have the *EnableStackSwap* flag set (kernel drivers can disable this with the *KeSetKernelStackSwapEnable* API).
- The thread's priority must be at or below the Win32 real-time priority range start (24—the default for a normal thread in the "real-time" process priority class).

The structure of a wait block is always fixed, but some of its fields are used in different ways depending on the type of wait. For example, typically, the wait block has a pointer to the object being waited on, but as we pointed out earlier, for an *alert-by-ID* wait, there is no object involved, so this represents the *Hint* that was specified by the caller. Similarly, while a wait block usually points back to the thread waiting on the object, it can also point to the queue of an I/O completion port, in the case where a wait completion packet was associated with the object as part of an asynchronous wait.

Two fields that are always maintained, however, are the *wait type* and the *wait block state*, and, depending on the type, a *wait key* can also be present. The *wait type* is very important during wait satisfaction because it determines which of the five possible types of satisfaction regimes to use: for a *wait any*, the kernel does not care about the state of any other object because at least one of them (the current one!) is now signaled. On the other hand, for a *wait all*, the kernel can only wake the thread if *all* the other objects are also in a signaled state at the same time, which requires iterating over the wait blocks and their associated objects.

Alternatively, a *wait dequeue* is a specialized case for situations where the dispatcher object is actually a queue (I/O completion port), and there is a thread waiting on it to have completion packets available (by calling *KeRemoveQueue(Ex)* or *(Nt)IoRemoveIoCompletion*). Wait blocks attached to queues function in a LIFO wake order (instead of FIFO like other dispatcher objects), so when a queue is signaled, this allows the correct actions to be taken (keep in mind that a thread could be waiting on multiple objects, so it could have other wait blocks, in a *wait any* or *wait all* state, that must still be handled regularly).

For a *wait notification*, the kernel knows that no thread is associated with the object at all and that this is an asynchronous wait with an associated I/O completion port whose queue will be signaled. (Because a queue is itself a dispatcher object, this causes a second order wait satisfaction for the queue and any threads potentially waiting on it.)

Finally, a *wait DPC*, which is the newest wait type introduced, lets the kernel know that there is no thread nor I/O completion port associated with this wait, but a DPC object instead. In this case, the pointer is to an initialized KDPC structure, which the kernel queues on the current processor for nearly immediate execution once the dispatcher lock is dropped.

The wait block also contains a volatile *wait block state* (*KWAIT_BLOCK_STATE*) that defines the current state of this wait block in the transactional wait operation it is currently engaged in. The different states, their meaning, and their effects in the wait logic code are explained in Table 8-28.

TABLE 8-28 Wait block states

State	Meaning	Effect
<i>WaitBlockActive</i> (4)	This wait block is actively linked to an object as part of a thread that is in a wait state.	During wait satisfaction, this wait block will be unlinked from the wait block list.
<i>WaitBlockInactive</i> (5)	The thread wait associated with this wait block has been satisfied (or the timeout has already expired while setting it up).	During wait satisfaction, this wait block will not be unlinked from the wait block list because the wait satisfaction must have already unlinked it during its active state.
<i>WaitBlockSuspended</i> (6)	The thread associated with this wait block is undergoing a <i>lightweight suspend</i> operation.	Essentially treated the same as <i>WaitBlockActive</i> but only ever used when resuming a thread. Ignored during regular wait satisfaction (should never be seen, as suspended threads can't be waiting on something too!).
<i>WaitBlockBypassStart</i> (0)	A signal is being delivered to the thread while the wait has not yet been committed.	During wait satisfaction (which would be immediate, before the thread enters the true wait state), the waiting thread must synchronize with the signaler because there is a risk that the wait object might be on the stack—marking the wait block as inactive would cause the waiter to unwind the stack while the signaler might still be accessing it.
<i>WaitBlockBypassComplete</i> (1)	The thread wait associated with this wait block has now been properly synchronized (the wait satisfaction has completed), and the bypass scenario is now completed.	The wait block is now essentially treated the same as an inactive wait block (ignored).
<i>WaitBlockSuspendBypassStart</i> (2)	A signal is being delivered to the thread while the lightweight suspend has not yet been committed.	The wait block is treated essentially the same as a <i>WaitBlockBypassStart</i> .
<i>WaitBlockSuspendBypassComplete</i> (3)	The lightweight suspend associated with this wait block has now been properly synchronized.	The wait block now behaves like a <i>WaitBlockSuspended</i> .

Finally, we mentioned the existence of a wait status register. With the removal of the global kernel dispatcher lock in Windows 7, the overall state of the thread (or any of the objects it is being required to start waiting on) can now change while wait operations are still being set up. Since there's no longer any global state synchronization, there is nothing to stop another thread—executing on a different logical processor—from signaling one of the objects being waited, or alerting the thread, or even sending it an APC. As such, the kernel dispatcher keeps track of a couple of additional data points for

each waiting thread object: the current fine-grained wait state of the thread (*KWAIT_STATE*, not to be confused with the wait block state) and any pending state changes that could modify the result of an ongoing wait operation. These two pieces of data are what make up the wait status register (*KWAIT_STATUS_REGISTER*).

When a thread is instructed to wait for a given object (such as due to a *WaitForSingleObject* call), it first attempts to enter the in-progress wait state (*WaitInProgress*) by beginning the wait. This operation succeeds if there are no pending alerts to the thread at the moment (based on the alertability of the wait and the current processor mode of the wait, which determine whether the alert can preempt the wait). If there is an alert, the wait is not entered at all, and the caller receives the appropriate status code; otherwise, the thread now enters the *WaitInProgress* state, at which point the main thread state is set to *Waiting*, and the wait reason and wait time are recorded, with any timeout specified also being registered.

Once the wait is in progress, the thread can initialize the wait blocks as needed (and mark them as *WaitBlockActive* in the process) and then proceed to lock all the objects that are part of this wait. Because each object has its own lock, it is important that the kernel be able to maintain a consistent locking ordering scheme when multiple processors might be analyzing a wait chain consisting of many objects (caused by a *WaitForMultipleObjects* call). The kernel uses a technique known as *address ordering* to achieve this: because each object has a distinct and static kernel-mode address, the objects can be ordered in monotonically increasing address order, guaranteeing that locks are always acquired and released in the same order by all callers. This means that the caller-supplied array of objects will be duplicated and sorted accordingly.

The next step is to check for immediate satisfaction of the wait, such as when a thread is being told to wait on a mutex that has already been released or an event that is already signaled. In such cases, the wait is immediately satisfied, which involves unlinking the associated wait blocks (however, in this case, no wait blocks have yet been inserted) and performing a wait exit (processing any pending scheduler operations marked in the wait status register). If this shortcut fails, the kernel next attempts to check whether the timeout specified for the wait (if any) has already expired. In this case, the wait is not “satisfied” but merely “timed out,” which results in slightly faster processing of the exit code, albeit with the same result.

If none of these shortcuts were effective, the wait block is inserted into the thread’s wait list, and the thread now attempts to commit its wait. (Meanwhile, the object lock or locks have been released, allowing other processors to modify the state of any of the objects that the thread is now supposed to attempt waiting on.) Assuming a noncontended scenario, where other processors are not interested in this thread or its wait objects, the wait switches into the committed state as long as there are no pending changes marked by the wait status register. The commit operation links the waiting thread in the PRCB list, activates an extra wait queue thread if needed, and inserts the timer associated with the wait timeout, if any. Because potentially quite a lot of cycles have elapsed by this point, it is again possible that the timeout has already elapsed. In this scenario, inserting the timer causes immediate signaling of the thread and thus a wait satisfaction on the timer and the overall timeout of the wait. Otherwise, in the much more common scenario, the CPU now context-switches away to the next thread that is ready for execution. (See Chapter 4 of Part 1 for more information on scheduling.)

In highly contended code paths on multiprocessor machines, it is possible and likely that the thread attempting to commit its wait has experienced a change while its wait was still in progress. One

possible scenario is that one of the objects it was waiting on has just been signaled. As touched upon earlier, this causes the associated wait block to enter the *WaitBlockBypassStart* state, and the thread's wait status register now shows the *WaitAborted* wait state. Another possible scenario is for an alert or APC to have been issued to the waiting thread, which does not set the *WaitAborted* state but enables one of the corresponding bits in the wait status register. Because APCs can break waits (depending on the type of APC, wait mode, and alertability), the APC is delivered, and the wait is aborted. Other operations that modify the wait status register without generating a full abort cycle include modifications to the thread's priority or affinity, which are processed when exiting the wait due to failure to commit, as with the previous cases mentioned.

As we briefly touched upon earlier, and in Chapter 4 of Part 1 in the scheduling section, recent versions of Windows implemented a *lightweight suspend* mechanism when *SuspendThread* and *ResumeThread* are used, which no longer always queues an APC that then acquires the suspend event embedded in the thread object. Instead, if the following conditions are true, an existing wait is instead *converted* into a suspend state:

- *KiDisableLightWeightSuspend* is 0 (administrators can use the *DisableLightWeightSuspend* value in the HKLM\SYSTEM\CurrentControlSet\Session Manager\Kernel registry key to turn off this optimization).
- The thread state is *Waiting*—that is, the thread is already in a wait state.
- The wait status register is set to *WaitCommitted*—that is, the thread's wait has been fully engaged.
- The thread is not an UMS primary or scheduled thread (see Chapter 4 of Part 1 for more information on User Mode Scheduling) because these require additional logic implemented in the scheduler's suspend APC.
- The thread issued a wait while at IRQL 0 (passive level) because waits at *APC_LEVEL* require special handling that only the suspend APC can provide.
- The thread does not have APCs currently disabled, nor is there an APC in progress, because these situations require additional synchronization that only the delivery of the scheduler's suspend APC can achieve.
- The thread is not currently attached to a different process due to a call to *KeStackAttachProcess* because this requires special handling just like the preceding bullet.
- If the first wait block associated with the thread's wait is not in a *WaitBlockInactive* block state, its wait type must be *WaitAll*; otherwise, this means that there's at least one active *WaitAny* block.

As the preceding list of criteria is hinting, this conversion happens by taking any currently active wait blocks and converting them to a *WaitBlockSuspended* state instead. If the wait block is currently pointing to an object, it is unlinked from its dispatcher header's wait list (such that signaling the object will no longer wake up this thread). If the thread had a timer associated with it, it is canceled and removed from the thread's wait block array, and a flag is set to remember that this was done. Finally, the original wait mode (Kernel or User) is also preserved in a flag as well.

Because it no longer uses a true wait object, this mechanism required the introduction of the three additional wait block states shown in Table 8-28 as well as four new wait states: *WaitSuspendInProgress*, *WaitSuspended*, *WaitResumeInProgress*, and *WaitResumeAborted*. These new states behave in a similar manner to their regular counterparts but address the same possible race conditions described earlier during a lightweight suspend operation.

For example, when a thread is resumed, the kernel detects whether it was placed in a lightweight suspend state and essentially undoes the operation, setting the wait register to *WaitResumeInProgress*. Each wait block is then enumerated, and for any block in the *WaitBlockSuspended* state, it is placed in *WaitBlockActive* and linked back into the object's dispatcher header's wait block list, unless the object became signaled in the meantime, in which case it is made *WaitBlockInactive* instead, just like in a regular wake operation. Finally, if the thread had a timeout associated with its wait that was canceled, the thread's timer is reinserted into the timer table, maintaining its original expiration (timeout) time.

Figure 8-39 shows the relationship of dispatcher objects to wait blocks to threads to PRCB (it assumes the threads are eligible for stack swapping). In this example, CPU 0 has two waiting (committed) threads: Thread 1 is waiting for object B, and thread 2 is waiting for objects A and B. If object A is signaled, the kernel sees that because thread 2 is also waiting for another object, thread 2 can't be readied for execution. On the other hand, if object B is signaled, the kernel can ready thread 1 for execution right away because it isn't waiting for any other objects. (Alternatively, if thread 1 was also waiting for other objects but its wait type was a *WaitAny*, the kernel could still wake it up.)

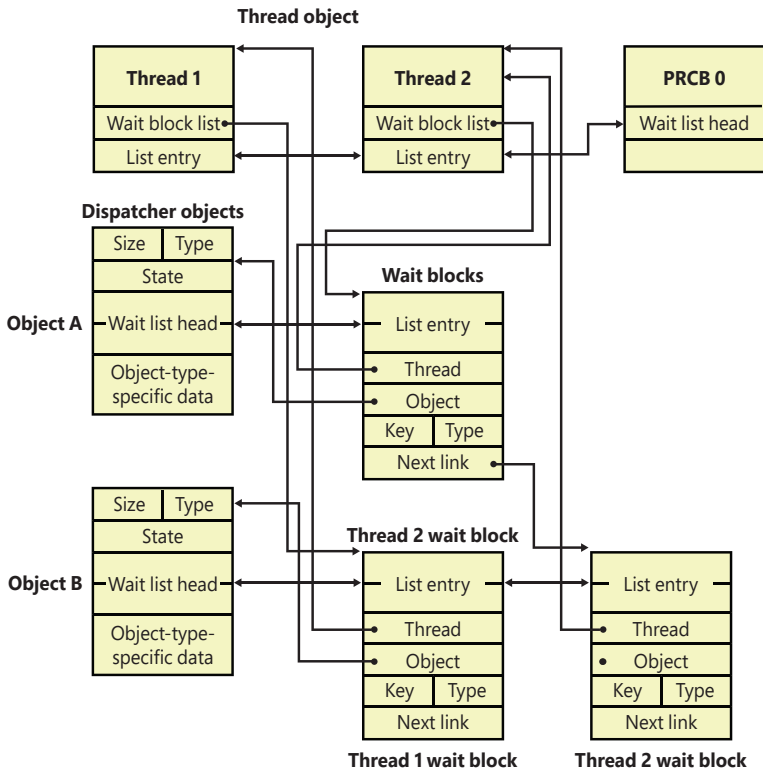

FIGURE 8-39 Wait data structures.

EXPERIMENT: Looking at wait queues

You can see the list of objects a thread is waiting for with the kernel debugger's **!thread** command. For example, the following excerpt from the output of a **!process** command shows that the thread is waiting for an event object:

```
!kd> !process 0 4 explorer.exe
```

```
THREAD ffff898f2b345080 Cid 27bc.137c Teb: 00000000006ba000
Win32Thread: 0000000000000000 WAIT: (UserRequest) UserMode Non-Alertable
ffff898f2b64ba60 SynchronizationEvent
```

You can use the **dx** command to interpret the dispatcher header of the object like this:

```
!kd> dx (nt!_DISPATCHER_HEADER*)0xffff898f2b64ba60
(nt!_DISPATCHER_HEADER*)0xffff898f2b64ba60: 0xffff898f2b64ba60 [Type: _DISPATCHER_HEADER*]
[+0x000] Lock : 393217 [Type: long]
[+0x000] LockNV : 393217 [Type: long]
[+0x000] Type : 0x1 [Type: unsigned char]
[+0x001] Signalling : 0x0 [Type: unsigned char]
[+0x002] Size : 0x6 [Type: unsigned char]
[+0x003] Reserved1 : 0x0 [Type: unsigned char]
[+0x000] TimerType : 0x1 [Type: unsigned char]
[+0x001] TimerControlFlags : 0x0 [Type: unsigned char]
[+0x001 ( 0: 0)] Absolute : 0x0 [Type: unsigned char]
[+0x001 ( 1: 1)] Wake : 0x0 [Type: unsigned char]
[+0x001 ( 7: 2)] EncodedTolerableDelay : 0x0 [Type: unsigned char]
[+0x002] Hand : 0x6 [Type: unsigned char]
[+0x003] TimerMiscFlags : 0x0 [Type: unsigned char]
[+0x003 ( 5: 0)] Index : 0x0 [Type: unsigned char]
[+0x003 ( 6: 6)] Inserted : 0x0 [Type: unsigned char]
[+0x003 ( 7: 7)] Expired : 0x0 [Type: unsigned char]
[+0x000] Timer2Type : 0x1 [Type: unsigned char]
[+0x001] Timer2Flags : 0x0 [Type: unsigned char]
[+0x001 ( 0: 0)] Timer2Inserted : 0x0 [Type: unsigned char]
[+0x001 ( 1: 1)] Timer2Expiring : 0x0 [Type: unsigned char]
[+0x001 ( 2: 2)] Timer2CancelPending : 0x0 [Type: unsigned char]
[+0x001 ( 3: 3)] Timer2SetPending : 0x0 [Type: unsigned char]
[+0x001 ( 4: 4)] Timer2Running : 0x0 [Type: unsigned char]
[+0x001 ( 5: 5)] Timer2Disabled : 0x0 [Type: unsigned char]
[+0x001 ( 7: 6)] Timer2ReservedFlags : 0x0 [Type: unsigned char]
[+0x002] Timer2ComponentId : 0x6 [Type: unsigned char]
[+0x003] Timer2RelativeId : 0x0 [Type: unsigned char]
[+0x000] QueueType : 0x1 [Type: unsigned char]
[+0x001] QueueControlFlags : 0x0 [Type: unsigned char]
[+0x001 ( 0: 0)] Abandoned : 0x0 [Type: unsigned char]
[+0x001 ( 1: 1)] DisableIncrement : 0x0 [Type: unsigned char]
[+0x001 ( 7: 2)] QueueReservedControlFlags : 0x0 [Type: unsigned char]
[+0x002] QueueSize : 0x6 [Type: unsigned char]
[+0x003] QueueReserved : 0x0 [Type: unsigned char]
[+0x000] ThreadType : 0x1 [Type: unsigned char]
[+0x001] ThreadReserved : 0x0 [Type: unsigned char]
[+0x002] ThreadControlFlags : 0x6 [Type: unsigned char]
[+0x002 ( 0: 0)] CycleProfiling : 0x0 [Type: unsigned char]
[+0x002 ( 1: 1)] CounterProfiling : 0x1 [Type: unsigned char]
```

```

[+0x002 ( 2: 2)] GroupScheduling : 0x1 [Type: unsigned char]
[+0x002 ( 3: 3)] AffinitySet : 0x0 [Type: unsigned char]
[+0x002 ( 4: 4)] Tagged : 0x0 [Type: unsigned char]
[+0x002 ( 5: 5)] EnergyProfiling : 0x0 [Type: unsigned char]
[+0x002 ( 6: 6)] SchedulerAssist : 0x0 [Type: unsigned char]
[+0x002 ( 7: 7)] ThreadReservedControlFlags : 0x0 [Type: unsigned char]
[+0x003] DebugActive : 0x0 [Type: unsigned char]
[+0x003 ( 0: 0)] ActiveDR7 : 0x0 [Type: unsigned char]
[+0x003 ( 1: 1)] Instrumented : 0x0 [Type: unsigned char]
[+0x003 ( 2: 2)] Minimal : 0x0 [Type: unsigned char]
[+0x003 ( 5: 3)] Reserved4 : 0x0 [Type: unsigned char]
[+0x003 ( 6: 6)] UmsScheduled : 0x0 [Type: unsigned char]
[+0x003 ( 7: 7)] UmsPrimary : 0x0 [Type: unsigned char]
[+0x000] MutantType : 0x1 [Type: unsigned char]
[+0x001] MutantSize : 0x0 [Type: unsigned char]
[+0x002] DpcActive : 0x6 [Type: unsigned char]
[+0x003] MutantReserved : 0x0 [Type: unsigned char]
[+0x004] SignalState : 0 [Type: long]
[+0x008] WaitListHead [Type: _LIST_ENTRY]
    [+0x000] Flink : 0xfffff898f2b3451c0 [Type: _LIST_ENTRY *]
    [+0x008] Blink : 0xfffff898f2b3451c0 [Type: _LIST_ENTRY *]

```

Because this structure is a union, you should ignore any values that do not correspond to the given object type because they are not relevant to it. Unfortunately, it is not easy to tell which fields are relevant to which type, other than by looking at the Windows kernel source code or the WDK header files' comments. For convenience, Table 8-29 lists the dispatcher header flags and the objects to which they apply.

TABLE 8-29 Usage and meaning of the dispatcher header flags

Flag	Applies To	Meaning
<i>Type</i>	All dispatcher objects	Value from the KOBJECTS enumeration that identifies the type of dispatcher object that this is.
<i>Lock</i>	All objects	Used for locking an object during wait operations that need to modify its state or linkage; actually corresponds to bit 7 (0x80) of the <i>Type</i> field.
<i>Signaling</i>	Gates	A priority boost should be applied to the woken thread when the gate is signaled.
<i>Size</i>	Events, Semaphores, Gates, Processes	Size of the object divided by 4 to fit in a single byte.
<i>Timer2Type</i>	Idle Resilient Timers	Mapping of the <i>Type</i> field.
<i>Timer2Inserted</i>	Idle Resilient Timers	Set if the timer was inserted into the timer handle table.
<i>Timer2Expiring</i>	Idle Resilient Timers	Set if the timer is undergoing expiration.
<i>Timer2CancelPending</i>	Idle Resilient Timers	Set if the timer is being canceled.
<i>Timer2SetPending</i>	Idle Resilient Timers	Set if the timer is being registered.
<i>Timer2Running</i>	Idle Resilient Timers	Set if the timer's callback is currently active.
<i>Timer2Disabled</i>	Idle Resilient Timers	Set if the timer has been disabled.

Flag	Applies To	Meaning
<i>Timer2ComponentId</i>	Idle Resilient Timers	Identifies the well-known component associated with the timer.
<i>Timer2Relativeld</i>	Idle Resilient Timers	Within the component ID specified earlier, identifies which of its timers this is.
<i>TimerType</i>	Timers	Mapping of the Type field.
<i>Absolute</i>	Timers	The expiration time is absolute, not relative.
<i>Wake</i>	Timers	This is a wakeable timer, meaning it should exit a standby state when signaled.
<i>EncodedTolerableDelay</i>	Timers	The maximum amount of tolerance (shifted as a power of two) that the timer can support when running outside of its expected periodicity.
<i>Hand</i>	Timers	Index into the timer handle table.
<i>Index</i>	Timers	Index into the timer expiration table.
<i>Inserted</i>	Timers	Set if the timer was inserted into the timer handle table.
<i>Expired</i>	Timers	Set if the timer has already expired.
<i>ThreadType</i>	Threads	Mapping of the <i>Type</i> field.
<i>ThreadReserved</i>	Threads	Unused.
<i>CycleProfiling</i>	Threads	CPU cycle profiling has been enabled for this thread.
<i>CounterProfiling</i>	Threads	Hardware CPU performance counter monitoring/profiling has been enabled for this thread.
<i>GroupScheduling</i>	Threads	Scheduling groups have been enabled for this thread, such as when running under DFSS mode (Distributed Fair-Share Scheduler) or with a Job Object that implements CPU throttling.
<i>AffinitySet</i>	Threads	The thread has a CPU Set associated with it.
<i>Tagged</i>	Threads	The thread has been assigned a property tag.
<i>EnergyProfiling</i>	Threads	Energy estimation is enabled for the process that this thread belongs to.
<i>SchedulerAssist</i>	Threads	The Hyper-V XTS (eXTended Scheduler) is enabled, and this thread belongs to a virtual processor (VP) thread inside of a VM minimal process.
<i>Instrumented</i>	Threads	Specifies whether the thread has a user-mode instrumentation callback.
<i>ActiveDR7</i>	Threads	Hardware breakpoints are being used, so DR7 is active and should be sanitized during context operations. This flag is also sometimes called <i>DebugActive</i> .
<i>Minimal</i>	Threads	This thread belongs to a minimal process.
<i>AltSyscall</i>	Threads	An alternate system call handler has been registered for the process that owns this thread, such as a Pico Provider or a Windows CE PAL.

Flag	Applies To	Meaning
<i>UmsScheduled</i>	Threads	This thread is a UMS Worker (scheduled) thread.
<i>UmsPrimary</i>	Threads	This thread is a UMS Scheduler (primary) thread.
<i>MutantType</i>	Mutants	Mapping of the <i>Type</i> field.
<i>MutantSize</i>	Mutants	Unused.
<i>DpcActive</i>	Mutants	The mutant was acquired during a DPC.
<i>MutantReserved</i>	Mutants	Unused.
<i>QueueType</i>	Queues	Mapping of the <i>Type</i> field.
<i>Abandoned</i>	Queues	The queue no longer has any threads that are waiting on it.
<i>DisableIncrement</i>	Queues	No priority boost should be given to a thread waking up to handle a packet on the queue.

Finally, the dispatcher header also has the *SignalState* field, which we previously mentioned, and the *WaitListHead*, which was also described. Keep in mind that when the wait list head pointers are identical, this can either mean that there are no threads waiting or that one thread is waiting on this object. You can tell the difference if the identical pointer happens to be the address of the list itself—which indicates that there’s no waiting thread at all. In the earlier example, 0XFFFF898F2B3451C0 was not the address of the list, so you can dump the wait block as follows:

```

1kd> dx (nt!_KWAIT_BLOCK*)0xffff898f2b3451c0
(nt!_KWAIT_BLOCK*)0xffff898f2b3451c0 : 0xffff898f2b3451c0 [Type: _KWAIT_BLOCK *]
    [+0x000] WaitListEntry [Type: _LIST_ENTRY]
    [+0x010] WaitType : 0x1 [Type: unsigned char]
    [+0x011] BlockState : 0x4 [Type: unsigned char]
    [+0x012] WaitKey : 0x0 [Type: unsigned short]
    [+0x014] SpareLong : 6066 [Type: long]
    [+0x018] Thread : 0xffff898f2b345080 [Type: _KTHREAD *]
    [+0x018] NotificationQueue : 0xffff898f2b345080 [Type: _KQUEUE *]
    [+0x020] Object : 0xffff898f2b64ba60 [Type: void *]
    [+0x028] SparePtr : 0x0 [Type: void *]

```

In this case, the wait type indicates a *WaitAny*, so we know that there is a thread blocking on the event, whose pointer we are given. We also see that the wait block is active. Next, we can investigate a few wait-related fields in the thread structure:

```

1kd> dt nt!_KTHREAD 0xffff898f2b345080 WaitRegister.State WaitIrql WaitMode WaitBlockCount
    WaitReason WaitTime
+0x070 WaitRegister :
+0x000 State : 0y001
+0x186 WaitIrql : 0 ''
+0x187 WaitMode : 1 ''
+0x1b4 WaitTime : 0x39b38f8
+0x24b WaitBlockCount : 0x1 ''
+0x283 WaitReason : 0x6 ''

```

The data shows that this is a committed wait that was performed at IRQL 0 (Passive Level) with a wait mode of *UserMode*, at the time shown in 15 ms clock ticks since boot, with the reason indicating a user-mode application request. We can also see that this is the only wait block this thread has, meaning that it is not waiting for any other object.

If the wait list head had more than one entry, you could've executed the same commands on the second pointer value in the *WaitListEntry* field of the wait block (and eventually executing *!thread* on the thread pointer in the wait block) to traverse the list and see what other threads are waiting for the object. If those threads were waiting for more than one object, you'd have to look at their *WaitBlockCount* to see how many other wait blocks were present, and simply keep incrementing the pointer by *sizeof(KWAIT_BLOCK)*.

Another possibility is that the wait type would have been *WaitNotification*, at which point you'd have used the notification queue pointer instead to dump the Queue (*KQUEUE*) structure, which is itself a dispatcher object. Potentially, it would also have had its own nonempty wait block list, which would have revealed the wait block associated with the worker thread that will be asynchronously receiving the notification that the object has been signaled. To determine which callback would eventually execute, you would have to dump user-mode thread pool data structures.

Keyed events

A synchronization object called a *keyed event* bears special mention because of the role it played in user-mode-exclusive synchronization primitives and the development of the *alert-by-ID* primitive, which you'll shortly realize is Windows' equivalent of the *futex* in the Linux operating system (a well-studied computer science concept). Keyed events were originally implemented to help processes deal with low-memory situations when using critical sections, which are user-mode synchronization objects that we'll see more about shortly. A keyed event, which is not documented, allows a thread to specify a "key" for which it waits, where the thread wakes when another thread of the same process signals the event with the same key. As we pointed out, if this sounds familiar to the alerting mechanism, it is because keyed events were its precursor.

If there was contention, *EnterCriticalSection* would dynamically allocate an event object, and the thread wanting to acquire the critical section would wait for the thread that owns the critical section to signal it in *LeaveCriticalSection*. Clearly, this introduces a problem during low-memory conditions: critical section acquisition could fail because the system was unable to allocate the event object required. In a pathological case, the low-memory condition itself might have been caused by the application trying to acquire the critical section, so the system would deadlock in this situation. Low memory wasn't the only scenario that could cause this to fail—a less likely scenario was handle exhaustion. If the process reached its handle limit, the new handle for the event object could fail.

It might seem that preallocating a global standard event object, similar to the *reserve objects* we talked about previously, would fix the issue. However, because a process can have multiple critical sections, each of which can have its own locking state, this would require an unknown number of pre-located event objects, and the solution doesn't work. The main feature of *keyed* events, however, was

that a single event could be reused among different threads, as long as each one provided a different key to distinguish itself. By providing the virtual address of the critical section itself as the key, this effectively allows multiple critical sections (and thus, waiters) to use the same keyed event handle, which can be preallocated at process startup time.

When a thread signals a keyed event or performs a wait on it, it uses a unique identifier called a *key*, which identifies the instance of the keyed event (an association of the keyed event to a single critical section). When the owner thread releases the keyed event by signaling it, only a single thread waiting on the key is woken up (the same behavior as *synchronization events*, in contrast to *notification events*). Going back to our use case of critical sections using their address as a key, this would imply that each process still needs its own keyed event because virtual addresses are obviously unique to a single process address space. However, it turns out that the kernel can wake only the waiters in the current process so that the key is even isolated across processes, meaning that there can be only a single keyed event object for the entire system.

As such, when *EnterCriticalSection* called *NtWaitForKeyedEvent* to perform a wait on the keyed event, it gave a NULL handle as parameter for the keyed event, telling the kernel that it was unable to create a keyed event. The kernel recognizes this behavior and uses a global keyed event named *ExpCritSecOutOfMemoryEvent*. The primary benefit is that processes don't need to waste a handle for a named keyed event anymore because the kernel keeps track of the object and its references.

However, keyed events were more than just a fallback object for low-memory conditions. When multiple waiters are waiting on the same key and need to be woken up, the key is signaled multiple times, which requires the object to keep a list of all the waiters so that it can perform a “wake” operation on each of them. (Recall that the result of signaling a keyed event is the same as that of signaling a synchronization event.) However, a thread can signal a keyed event without any threads on the waiter list. In this scenario, the signaling thread instead waits on the event itself.

Without this fallback, a signaling thread could signal the keyed event during the time that the user-mode code saw the keyed event as unsignaled and attempt a wait. The wait might have come *after* the signaling thread signaled the keyed event, resulting in a missed pulse, so the waiting thread would deadlock. By forcing the signaling thread to wait in this scenario, it actually signals the keyed event only when someone is looking (waiting). This behavior made them similar, but not identical, to the Linux *futex*, and enabled their usage across a number of user-mode primitives, which we'll see shortly, such as Slim Read Writer (SRW) Locks.



Note When the keyed-event wait code needs to perform a wait, it uses a built-in semaphore located in the kernel-mode thread object (ETHREAD) called *KeyedWaitSemaphore*. (This semaphore shares its location with the ALPC wait semaphore.) See Chapter 4 of Part 1 for more information on thread objects.

Keyed events, however, did not replace standard event objects in the critical section implementation. The initial reason, during the Windows XP timeframe, was that keyed events did not offer scalable performance in heavy-usage scenarios. Recall that all the algorithms described were meant to be used

only in critical, low-memory scenarios, when performance and scalability aren't all that important. To replace the standard event object would've placed strain on keyed events that they weren't implemented to handle. The primary performance bottleneck was that keyed events maintained the list of waiters described in a doubly linked list. This kind of list has poor *traversal speed*, meaning the time required to loop through the list. In this case, this time depended on the number of waiter threads. Because the object is global, dozens of threads could be on the list, requiring long traversal times every single time a key was set or waited on.



Note The head of the list is kept in the keyed event object, whereas the threads are linked through the *KeyedWaitChain* field (which is shared with the thread's exit time, stored as a *LARGE_INTEGER*, the same size as a doubly linked list) in the kernel-mode thread object (ETHREAD). See Chapter 4 of Part 1 for more information on this object.

Windows Vista improved keyed-event performance by using a hash table instead of a linked list to hold the waiter threads. This optimization is what ultimately allowed Windows to include the three new lightweight user-mode synchronization primitives (to be discussed shortly) that all depended on the keyed event. Critical sections, however, continued to use event objects, primarily for application compatibility and debugging, because the event object and internals are well known and documented, whereas keyed events are opaque and not exposed to the Win32 API.

With the introduction of the new alerting by Thread ID capabilities in Windows 8, however, this all changed again, removing the usage of keyed events across the system (save for one situation in *init once* synchronization, which we'll describe shortly). And, as more time had passed, the critical section structure eventually dropped its usage of a regular event object and moved toward using this new capability as well (with an application compatibility shim that can revert to using the original event object if needed).

Fast mutexes and guarded mutexes

Fast mutexes, which are also known as executive mutexes, usually offer better performance than mutex objects because, although they are still built on a dispatcher object—an event—they perform a wait only if the fast mutex is contended. Unlike a standard mutex, which always attempts the acquisition through the dispatcher, this gives the fast mutex especially good performance in contended environments. Fast mutexes are used widely in device drivers.

This efficiency comes with costs, however, as fast mutexes are only suitable when *all* kernel-mode APC (described earlier in this chapter) delivery can be disabled, unlike regular mutex objects that block only *normal* APC delivery. Reflecting this, the executive defines two functions for acquiring them: *ExAcquireFastMutex* and *ExAcquireFastMutexUnsafe*. The former function blocks all APC delivery by raising the IRQL of the processor to APC level. The latter, “unsafe” function, expects to be called with all kernel-mode APC delivery already disabled, which can be done by raising the IRQL to APC level. *ExTryToAcquireFastMutex* performs similarly to the first, but it does not actually wait if the fast mutex is already held, returning *FALSE* instead. Another limitation of fast mutexes is that they can't be acquired recursively, unlike mutex objects.

In Windows 8 and later, guarded mutexes are identical to fast mutexes but are acquired with *KeAcquireGuardedMutex* and *KeAcquireGuardedMutexUnsafe*. Like fast mutexes, a *KeTryToAcquireGuardedMutex* method also exists.

Prior to Windows 8, these functions did not disable APCs by raising the IRQL to APC level, but by entering a guarded region instead, which set special counters in the thread's object structure to disable APC delivery until the region was exited, as we saw earlier. On older systems with a PIC (which we also talked about earlier in this chapter), this was faster than touching the IRQL. Additionally, guarded mutexes used a *gate* dispatcher object, which was slightly faster than an *event*—another difference that is no longer true.

Another problem related to the guarded mutex was the kernel function *KeAreApcsDisabled*. Prior to Windows Server 2003, this function indicated whether *normal* APCs were disabled by checking whether the code was running inside a critical section. In Windows Server 2003, this function was changed to indicate whether the code was in a critical or guarded region, changing the functionality to also return TRUE if special kernel APCs are also disabled.

Because there are certain operations that drivers should not perform when special kernel APCs are disabled, it made sense to call *KeGetCurrentIrql* to check whether the IRQL is APC level or not, which was the only way special kernel APCs could have been disabled. However, with the introduction of guarded regions and guarded mutexes, which were heavily used even by the memory manager, this check failed because guarded mutexes did not raise IRQL. Drivers then had to call *KeAreAllApcsDisabled* for this purpose, which also checked whether special kernel APCs were disabled through a guarded region. These idiosyncrasies, combined with fragile checks in Driver Verifier causing false positives, ultimately all led to the decision to simply make guarded mutexes revert to just being fast mutexes.

Executive resources

Executive resources are a synchronization mechanism that supports shared and exclusive access; like fast mutexes, they require that all kernel-mode APC delivery be disabled before they are acquired. They are also built on dispatcher objects that are used only when there is contention. Executive resources are used throughout the system, especially in file-system drivers, because such drivers tend to have long-lasting wait periods in which I/O should still be allowed to some extent (such as reads).

Threads waiting to acquire an executive resource for shared access wait for a semaphore associated with the resource, and threads waiting to acquire an executive resource for exclusive access wait for an event. A semaphore with unlimited count is used for shared waiters because they can all be woken and granted access to the resource when an exclusive holder releases the resource simply by signaling the semaphore. When a thread waits for exclusive access of a resource that is currently owned, it waits on a synchronization event object because only one of the waiters will wake when the event is signaled. In the earlier section on synchronization events, it was mentioned that some event *unwait* operations can actually cause a priority boost. This scenario occurs when executive resources are used, which is one reason why they also track ownership like mutexes do. (See Chapter 4 of Part 1 for more information on the executive resource priority boost.)

Because of the flexibility that shared and exclusive access offer, there are several functions for acquiring resources: *ExAcquireResourceSharedLite*, *ExAcquireResourceExclusiveLite*, *ExAcquireSharedStarveExclusive*, and *ExAcquireShareWaitForExclusive*. These functions are documented in the WDK.

Recent versions of Windows also added *fast* executive resources that use identical API names but add the word “fast,” such as *ExAcquireFastResourceExclusive*, *ExReleaseFastResource*, and so on. These are meant to be faster replacements due to different handling of lock ownership, but no component uses them other than the Resilient File System (ReFS). During highly contended file system access, ReFS has slightly better performance than NTFS, in part due to the faster locking.

EXPERIMENT: Listing acquired executive resources

The kernel debugger **!locks** command uses the kernel’s linked list of executive resources and dumps their state. By default, the command lists only executive resources that are currently owned, but the **-d** option is documented as listing all executive resources—unfortunately, this is no longer the case. However, you can still use the **-v** flag to dump verbose information on all resources instead. Here is partial output of the command:

```
!kd> !locks -v
**** DUMP OF ALL RESOURCE OBJECTS ****

Resource @ nt!ExpFirmwareTableResource (0xfffff8047ee34440) Available
Resource @ nt!PsLoadedModuleResource (0xfffff8047ee48120) Available
    Contention Count = 2
Resource @ nt!SepRmDbLock (0xfffff8047ef06350) Available
    Contention Count = 93
Resource @ nt!SepRmDbLock (0xfffff8047ef063b8) Available
Resource @ nt!SepRmDbLock (0xfffff8047ef06420) Available
Resource @ nt!SepRmDbLock (0xfffff8047ef06488) Available
Resource @ nt!SepRmGlobalSaclLock (0xfffff8047ef062b0) Available
Resource @ nt!SepLsaAuditQueueInfo (0xfffff8047ee6e010) Available
Resource @ nt!SepLsaDeletedLogonQueueInfo (0xfffff8047ee6ded0) Available
Resource @ 0xffff898f032a8550 Available
Resource @ nt!PnpRegistryDeviceResource (0xfffff8047ee62b00) Available
    Contention Count = 27385
Resource @ nt!PopPolicyLock (0xfffff8047ee458c0) Available
    Contention Count = 14
Resource @ 0xffff898f032a8950 Available
Resource @ 0xffff898f032a82d0 Available
```

Note that the contention count, which is extracted from the resource structure, records the number of times threads have tried to acquire the resource and had to wait because it was already owned. On a live system where you break in with the debugger, you might be lucky enough to catch a few held resources, as shown in the following output:

```
2: kd> !locks
**** DUMP OF ALL RESOURCE OBJECTS ****
KD: Scanning for held locks.....

Resource @ 0xffffde07a33d6a28 Shared 1 owning threads
    Contention Count = 28
    Threads: ffffde07a9374080-01<*>
```

```

KD: Scanning for held locks...

Resource @ 0xffffde07a2bfb350    Shared 1 owning threads
    Contention Count = 2
    Threads: ffffde07a9374080-01<*>
KD: Scanning for held locks.....

Resource @ 0xffffde07a8070c00    Shared 1 owning threads
    Threads: ffffde07aa3f1083-01<*> *** Actual Thread ffffde07aa3f1080
KD: Scanning for held locks.....

Resource @ 0xffffde07a8995900    Exclusively owned
    Threads: ffffde07a9374080-01<*>
KD: Scanning for held locks.....
    9706 total locks, 4 locks currently held

```

You can examine the details of a specific resource object, including the thread that owns the resource and any threads that are waiting for the resource, by specifying the `-v` switch and the address of the resource, if you find one that's currently acquired (owned). For example, here's a held shared resource that seems to be associated with NTFS, while a thread is attempting to read from the file system:

```

2: kd> !locks -v 0xffffde07a33d6a28

Resource @ 0xffffde07a33d6a28    Shared 1 owning threads
    Contention Count = 28
    Threads: ffffde07a9374080-01<*>

    THREAD ffffde07a9374080  Cid 0544.1494  Teb: 000000ed8de12000
    Win32Thread: 0000000000000000  WAIT: (Executive) KernelMode Non-Alertable
    ffff8287943a87b8  NotificationEvent
    IRP List:
        ffffde07a936da20: (0006,0478)  Flags: 00020043  Mdl: ffffde07a8a75950
        ffffde07a894fa20: (0006,0478)  Flags: 00000884  Mdl: 00000000
    Not impersonating
    DeviceMap                ffff8786fce35840
    Owning Process            ffffde07a7f990c0      Image:          svchost.exe
    Attached Process          N/A                Image:          N/A
    Wait Start TickCount      3649              Ticks: 0
    Context Switch Count      31                IdealProcessor: 1
    UserTime                  00:00:00.015
    KernelTime                00:00:00.000
    Win32 Start Address 0x00007ff926812390
    Stack Init ffff8287943aa650  Current ffff8287943a8030
    Base ffff8287943ab000  Limit ffff8287943a4000  Call 0000000000000000
    Priority 7 BasePriority 6 PriorityDecrement 0 IoPriority 0 PagePriority 1
    Child-SP      RetAddr      Call Site
    ffff8287`943a8070 fffff801`104a423a nt!KiSwapContext+0x76
    ffff8287`943a81b0 fffff801`104a5d53 nt!KiSwapThread+0x5ba
    ffff8287`943a8270 fffff801`104a6579 nt!KiCommitThreadWait+0x153
    ffff8287`943a8310 fffff801`1263e962 nt!KeWaitForSingleObject+0x239
    ffff8287`943a8400 fffff801`1263d682 Ntfs!NtfsNonCachedIo+0xa52
    ffff8287`943a86b0 fffff801`1263b756 Ntfs!NtfsCommonRead+0x1d52
    ffff8287`943a8850 fffff801`1049a725 Ntfs!NtfsFsdRead+0x396
    ffff8287`943a8920 fffff801`11826591 nt!IoCallDriver+0x55

```

Pushlocks

Pushlocks are another optimized synchronization mechanism built on event objects; like fast and guarded mutexes, they wait for an event only when there's contention on the lock. They offer advantages over them, however, in that they can also be acquired in shared or exclusive mode, just like an executive resource. Unlike the latter, however, they provide an additional advantage due to their size: a resource object is 104 bytes, but a pushlock is pointer sized. Because of this, pushlocks do not require allocation nor initialization and are guaranteed to work in low-memory conditions. Many components inside of the kernel moved away from executive resources to pushlocks, and modern third-party drivers all use pushlocks as well.

There are four types of pushlocks: normal, cache-aware, auto-expand, and address-based. Normal pushlocks require only the size of a pointer in storage (4 bytes on 32-bit systems, and 8 bytes on 64-bit systems). When a thread acquires a normal pushlock, the pushlock code marks the pushlock as owned if it is not currently owned. If the pushlock is owned exclusively or the thread wants to acquire the thread exclusively and the pushlock is owned on a shared basis, the thread allocates a wait block on the thread's stack, initializes an event object in the wait block, and adds the wait block to the wait list associated with the pushlock. When a thread releases a pushlock, the thread wakes a waiter, if any are present, by signaling the event in the waiter's wait block.

Because a pushlock is only pointer-sized, it actually contains a variety of bits to describe its state. The meaning of those bits changes as the pushlock changes from being contended to noncontended. In its initial state, the pushlock contains the following structure:

- One lock bit, set to 1 if the lock is acquired
- One waiting bit, set to 1 if the lock is contended and someone is waiting on it
- One waking bit, set to 1 if the lock is being granted to a thread and the waiter's list needs to be optimized
- One multiple shared bit, set to 1 if the pushlock is shared and currently acquired by more than one thread
- 28 (on 32-bit Windows) or 60 (on 64-bit Windows) share count bits, containing the number of threads that have acquired the pushlock

As discussed previously, when a thread acquires a pushlock exclusively while the pushlock is already acquired by either multiple readers or a writer, the kernel allocates a pushlock wait block. The structure of the pushlock value itself changes. The share count bits now become the pointer to the wait block. Because this wait block is allocated on the stack, and the header files contain a special alignment directive to force it to be 16-byte aligned, the bottom 4 bits of any pushlock wait-block structure will be all zeros. Therefore, those bits are ignored for the purposes of pointer dereferencing; instead, the 4 bits shown earlier are combined with the pointer value. Because this alignment removes the share count bits, the share count is now stored in the wait block instead.

A *cache-aware* pushlock adds layers to the normal (basic) pushlock by allocating a pushlock for each processor in the system and associating it with the cache-aware pushlock. When a thread wants to

acquire a cache-aware pushlock for shared access, it simply acquires the pushlock allocated for its current processor in shared mode; to acquire a cache-aware pushlock exclusively, the thread acquires the pushlock for each processor in exclusive mode.

As you can imagine, however, with Windows now supporting systems of up to 2560 processors, the number of potential cache-padded slots in the cache-aware pushlock would require immense fixed allocations, even on systems with few processors. Support for dynamic hot-add of processors makes the problem even harder because it would technically require the preallocation of all 2560 slots ahead of time, creating multi-KB lock structures. To solve this, modern versions of Windows also implement the *auto-expand* push lock. As the name suggests, this type of cache-aware pushlock can dynamically grow the number of cache slots as needed, both based on contention and processor count, while guaranteeing forward progress, leveraging the executive's *slot allocator*, which pre-reserves paged or nonpaged pool (depending on flags that were passed in when allocating the auto-expand pushlock).

Unfortunately for third-party developers, cache-aware (and their newer cousins, auto-expand) pushlocks are not officially documented for use, although certain data structures, such as FCB Headers in Windows 10 21H1 and later, do opaquely use them (more information about the *FCB* structure is available in Chapter 11.) Internal parts of the kernel in which auto-expand pushlocks are used include the memory manager, where they are used to protect Address Windowing Extension (AWE) data structures.

Finally, another kind of nondocumented, but exported, push-lock is the *address-based* pushlock, which rounds out the implementation with a mechanism similar to the address-based wait we'll shortly see in user mode. Other than being a different "kind" of pushlock, the address-based pushlock refers more to the interface behind its usage. On one end, a caller uses *ExBlockOnAddressPushLock*, passing in a pushlock, the virtual address of some variable of interest, the size of the variable (up to 8 bytes), and a comparison address containing the expected, or desired, value of the variable. If the variable does not currently have the expected value, a wait is initialized with *ExTimedWaitForUnblockPushLock*. This behaves similarly to contended pushlock acquisition, with the difference that a timeout value can be specified. On the other end, a caller uses *ExUnblockOnAddressPushLockEx* after making a change to an address that is being monitored to signal a waiter that the value has changed. This technique is especially useful when dealing with changes to data protected by a lock or interlocked operation, so that racing readers can wait for the writer's notification that their change is complete, outside of a lock. Other than a much smaller memory footprint, one of the large advantages that pushlocks have over executive resources is that in the noncontended case they do not require lengthy accounting and integer operations to perform acquisition or release. By being as small as a pointer, the kernel can use atomic CPU instructions to perform these tasks. (For example, on x86 and x64 processors, *lock cmpxchg* is used, which atomically compares and exchanges the old lock with a new lock.) If the atomic compare and exchange fails, the lock contains values the caller did not expect (callers usually expect the lock to be unused or acquired as shared), and a call is then made to the more complex contended version.

To improve performance even further, the kernel exposes the pushlock functionality as inline functions, meaning that no function calls are ever generated during noncontended acquisition—the assembly code is directly inserted in each function. This increases code size slightly, but it avoids the slowness of a function call. Finally, pushlocks use several algorithmic tricks to avoid lock convoys (a situation that can occur when multiple threads of the same priority are all waiting on a lock and little

actual work gets done), and they are also self-optimizing: the list of threads waiting on a pushlock will be periodically rearranged to provide fairer behavior when the pushlock is released.

One more performance optimization that is applicable to pushlock acquisition (including for address-based pushlocks) is the opportunistic spinlock-like behavior during contention, before performing the dispatcher object wait on the pushlock wait block's event. If the system has at least one other unparked processor (see Chapter 4 of Part 1 for more information on core parking), the kernel enters a tight spin-based loop for *ExpSpinCycleCount* cycles just like a spinlock would, but without raising the IRQL, issuing a yield instruction (such as a *pause* on x86/x64) for each iteration. If during any of the iterations, the pushlock now appears to be released, an interlocked operation to acquire the pushlock is performed.

If the spin cycle times out, or the interlocked operation failed (due to a race), or if the system does not have at least one additional unparked processor, then *KeWaitForSingleObject* is used on the event object in the pushlock wait block. *ExpSpinCycleCount* is set to 10240 cycles on any machine with more than one logical processor and is not configurable. For systems with an AMD processor that implements the MWAITT (MWAIT Timer) specification, the *monitorx* and *mwaitx* instructions are used instead of a spin loop. This hardware-based feature enables waiting, at the CPU level, for the value at an address to change without having to enter a loop, but they allow providing a timeout value so that the wait is not indefinite (which the kernel supplies based on *ExpSpinCycleCount*).

On a final note, with the introduction of the AutoBoost feature (explained in Chapter 4 of Part 1), pushlocks also leverage its capabilities by default, unless callers use the newer *ExXxxPushLockXxxEx*, functions, which allow passing in the *EX_PUSH_LOCK_FLAG_DISABLE_AUTOBOOST* flag that disables the functionality (which is not officially documented). By default, the non-*Ex* functions now call the newer *Ex* functions, but without supplying the flag.

Address-based waits

Based on the lessons learned with keyed events, the key synchronization primitive that the Windows kernel now exposes to user mode is the *alert-by-ID* system call (and its counterpart to *wait-on-alert-by-ID*). With these two simple system calls, which require no memory allocations or handles, any number of process-local synchronizations can be built, which will include the addressed-based waiting mechanism we're about to see, on top of which other primitives, such as critical sections and SRW locks, are based upon.

Address-based waiting is based on three documented Win32 API calls: *WaitOnAddress*, *WakeByAddressSingle*, and *WakeByAddressAll*. These functions in *KernelBase.dll* are nothing more than forwarders into *Ntdll.dll*, where the real implementations are present under similar names beginning with *Rtl*, standing for Run Time Library. The *Wait* API takes in an address pointing to a value of interest, the size of the value (up to 8 bytes), and the address of the undesired value, plus a timeout. The *Wake* APIs take in the address only.

First, *RtlWaitOnAddress* builds a local *address wait block* tracking the thread ID and address and inserts it into a per-process hash table located in the Process Environment Block (PEB). This mirrors the work done by *ExBlockOnAddressPushLock* as we saw earlier, except that a hash table wasn't needed because the caller had to store a push lock pointer somewhere. Next, just like the kernel API, *RtlWaitOnAddress* checks whether the target address already has a value different than the undesirable

one and, if so, removes the address wait block, returning FALSE. Otherwise, it will call an internal function to block.

If there is more than one unparked processor available, the blocking function will first attempt to avoid entering the kernel by spinning in user mode on the value of the address wait block bit indicating availability, based on the value of *RtlpWaitOnAddressSpinCount*, which is hardcoded to 1024 as long as the system has more than one processor. If the wait block still indicates contention, a system call is now made to the kernel using *NtWaitForAlertByThreadId*, passing in the address as the *hint* parameter, as well as the timeout.

If the function returns due to a timeout, a flag is set in the address wait block to indicate this, and the block is removed, with the function returning *STATUS_TIMEOUT*. However, there is a subtle race condition where the caller may have called the *Wake* function just a few cycles after the wait has timed out. Because the wait block flag is modified with a compare-exchange instruction, the code can detect this and actually calls *NtWaitForAlertByThreadId* a second time, this time without a timeout. This is guaranteed to return because the code knows that a wake is in progress. Note that in nontimeout cases, there's no need to remove the wait block, because the waker has already done so.

On the writer's side, both *RtlWakeOnAddressSingle* and *RtlWakeOnAddressAll* leverage the same helper function, which hashes the input address and looks it up in the PEB's hash table introduced earlier in this section. Carefully synchronizing with compare-exchange instructions, it removes the address wait block from the hash table, and, if committed to wake up any waiters, it iterates over all matching wait blocks for the same address, calling *NtAlertThreadByThreadId* for each of them, in the *All* usage of the API, or only the first one, in the *Single* version of the API.

With this implementation, we essentially now have a user-mode implementation of keyed events that does not rely on any kernel object or handle, not even a single global one, completely removing any failures in low-resource conditions. The only thing the kernel is responsible for is putting the thread in a wait state or waking up the thread from that wait state.

The next few sections cover various primitives that leverage this functionality to provide synchronization during contention.

Critical sections

Critical sections are one of the main synchronization primitives that Windows provides to user-mode application developers on top of the kernel-based synchronization primitives. Critical sections and the other user-mode primitives you'll see later have one major advantage over their kernel counterparts, which is saving a round trip to kernel mode in cases in which the lock is noncontended (which is typically 99 percent of the time or more). Contended cases still require calling the kernel, however, because it is the only piece of the system that can perform the complex waking and dispatching logic required to make these objects work.

Critical sections can remain in user mode by using a local bit to provide the main exclusive locking logic, much like a pushlock. If the bit is 0, the critical section can be acquired, and the owner sets the bit to 1. This operation doesn't require calling the kernel but uses the interlocked CPU operations discussed earlier. Releasing the critical section behaves similarly, with bit state changing from 1 to 0 with

an interlocked operation. On the other hand, as you can probably guess, when the bit is already 1 and another caller attempts to acquire the critical section, the kernel must be called to put the thread in a wait state.

Akin to pushlocks and address-based waits, critical sections implement a further optimization to avoid entering the kernel: spinning, much like a spinlock (albeit at IRQL 0—Passive Level) on the lock bit, hoping it clears up quickly enough to avoid the blocking wait. By default, this is set to 2000 cycles, but it can be configured differently by using the *InitializeCriticalSectionEx* or *InitializeCriticalSectionAndSpinCount* API at creation time, or later, by calling *SetCriticalSectionSpinCount*.



Note As we discussed, because *WaitForAddressSingle* already implements a busy spin wait as an optimization, with a default 1024 cycles, technically there are 3024 cycles spent spinning by default—first on the critical sections' lock bit and then on the wait address block's lock bit, before actually entering the kernel.

When they do need to enter the true contention path, critical sections will, the first time they're called, attempt to initialize their *LockSemaphore* field. On modern versions of Windows, this is only done if *RtlpForceCSToUseEvents* is set, which is the case if the *KACF_ALLOCDEBUGINFOFORCRITSECTIONS* (0x400000) flag is set through the Application Compatibility Database on the current process. If the flag is set, however, the underlying dispatcher event object will be created (even if the field refers to *semaphore*, the object is an event). Then, assuming that the event was created, a call to *WaitForSingleObject* is performed to block on the critical section (typically with a per-process configurable timeout value, to aid in the debugging of deadlocks, after which the wait is reattempted).

In cases where the application compatibility shim was not requested, or in extreme low-memory conditions where the shim *was* requested but the event could not be created, critical sections no longer use the event (nor any of the keyed event functionality described earlier). Instead, they directly leverage the address-based wait mechanism described earlier (also with the same deadlock detection timeout mechanism from the previous paragraph). The address of the local bit is supplied to the call to *WaitOnAddress*, and as soon as the critical section is released by *LeaveCriticalSection*, it either calls *SetEvent* on the event object or *WakeAddressSingle* on the local bit.



Note Even though we've been referring to APIs by their Win32 name, in reality, critical sections are implemented by *Ntdll.dll*, and *KernelBase.dll* merely forwards the functions to identical functions starting with *Rtl* instead, as they are part of the Run Time Library. Therefore, *RtlLeaveCriticalSection* calls *NtSetEvent*. *RtlWakeAddressSingle*, and so on.

Finally, because critical sections are not kernel objects, they have certain limitations. The primary one is that you cannot obtain a kernel handle to a critical section; as such, no security, naming, or other Object Manager functionality can be applied to a critical section. Two processes cannot use the same critical section to coordinate their operations, nor can duplication or inheritance be used.

User-mode resources

User-mode resources also provide more fine-grained locking mechanisms than kernel primitives. A resource can be acquired for shared mode or for exclusive mode, allowing it to function as a multiple-reader (shared), single-writer (exclusive) lock for data structures such as databases. When a resource is acquired in shared mode and other threads attempt to acquire the same resource, no trip to the kernel is required because none of the threads will be waiting. Only when a thread attempts to acquire the resource for exclusive access, or the resource is already locked by an exclusive owner, is this required.

To make use of the same dispatching and synchronization mechanism you saw in the kernel, resources make use of existing kernel primitives. A resource data structure (*RTL_RESOURCE*) contains handles to two kernel semaphore objects. When the resource is acquired exclusively by more than one thread, the resource releases the exclusive semaphore with a single release count because it permits only one owner. When the resource is acquired in shared mode by more than one thread, the resource releases the shared semaphore with as many release counts as the number of shared owners. This level of detail is typically hidden from the programmer, and these internal objects should never be used directly.

Resources were originally implemented to support the SAM (or Security Account Manager, which is discussed in Chapter 7 of Part 1) and not exposed through the Windows API for standard applications. Slim Reader-Writer Locks (SRW Locks), described shortly, were later implemented to expose a similar but highly optimized locking primitive through a documented API, although some system components still use the resource mechanism.

Condition variables

Condition variables provide a Windows native implementation for synchronizing a set of threads that are waiting on a specific result to a conditional test. Although this operation was possible with other user-mode synchronization methods, there was no *atomic* mechanism to check the result of the conditional test and to begin waiting on a change in the result. This required that additional synchronization be used around such pieces of code.

A user-mode thread initializes a condition variable by calling *InitializeConditionVariable* to set up the initial state. When it wants to initiate a wait on the variable, it can call *SleepConditionVariableCS*, which uses a critical section (that the thread must have initialized) to wait for changes to the variable, or, even better, *SleepConditionVariableSRW*, which instead uses a Slim Reader/Writer (SRW) lock, which we describe next, giving the caller the advantage to do a shared (reader) or exclusive (writer) acquisition.

Meanwhile, the setting thread must use *WakeConditionVariable* (or *WakeAllConditionVariable*) after it has modified the variable. This call releases the critical section or SRW lock of either one or all waiting threads, depending on which function was used. If this sounds like address-based waiting, it's because it is—with the additional guarantee of the atomic compare-and-wait operation. Additionally, condition variables were implemented before address-based waiting (and thus, before alert-by-ID) and had to rely on keyed events instead, which were only a close approximation of the desired behavior.

Before condition variables, it was common to use either a *notification event* or a *synchronization event* (recall that these are referred to as *auto-reset* or *manual-reset* in the Windows API) to signal the

change to a variable, such as the state of a worker queue. Waiting for a change required a critical section to be acquired and then released, followed by a wait on an event. After the wait, the critical section had to be reacquired. During this series of acquisitions and releases, the thread might have switched contexts, causing problems if one of the threads called *PulseEvent* (a similar problem to the one that keyed events solve by forcing a wait for the signaling thread if there is no waiter). With condition variables, acquisition of the critical section or SRW lock can be maintained by the application while *SleepConditionVariableCS/SRW* is called and can be released only after the actual work is done. This makes writing work-queue code (and similar implementations) much simpler and predictable.

With both SRW locks and critical sections moving to the address-based wait primitives, however, conditional variables can now directly leverage *NtWaitForAlertByThreadId* and directly signal the thread, while building a *conditional variable wait block* that's structurally similar to the *address wait block* we described earlier. The need for keyed events is thus completely elided, and they remain only for backward compatibility.

Slim Reader/Writer (SRW) locks

Although condition variables are a synchronization mechanism, they are not fully primitive locks because they do implicit value comparisons around their locking behavior and rely on higher-level abstractions to be provided (namely, a lock!). Meanwhile, address-based waiting *is* a primitive operation, but it provides only the basic synchronization primitive, not true locking. In between these two worlds, Windows has a true locking primitive, which is nearly identical to a pushlock: the Slim Reader/Writer lock (SRW lock).

Like their kernel counterparts, SRW locks are also pointer sized, use atomic operations for acquisition and release, rearrange their waiter lists, protect against lock convoys, and can be acquired both in shared and exclusive mode. Just like pushlocks, SRW locks can be upgraded, or converted, from shared to exclusive and vice versa, and they have the same restrictions around recursive acquisition. The only real difference is that SRW locks are exclusive to user-mode code, whereas pushlocks are exclusive to kernel-mode code, and the two cannot be shared or exposed from one layer to the other. Because SRW locks also use the *NtWaitForAlertByThreadId* primitive, they require no memory allocation and are guaranteed never to fail (other than through incorrect usage).

Not only can SRW locks entirely replace critical sections in application code, which reduces the need to allocate the large *CRITICAL_SECTION* structure (and which previously required the creation of an event object), but they also offer multiple-reader, single-writer functionality. SRW locks must first be initialized with *InitializeSRWLock* or can be statically initialized with a sentinel value, after which they can be acquired or released in either exclusive or shared mode with the appropriate APIs: *AcquireSRWLockExclusive*, *ReleaseSRWLockExclusive*, *AcquireSRWLockShared*, and *ReleaseSRWLockShared*. APIs also exist for opportunistically trying to acquire the lock, guaranteeing that no blocking operation will occur, as well as converting the lock from one mode to another.



Note Unlike most other Windows APIs, the SRW locking functions do not return with a value—instead, they generate exceptions if the lock could not be acquired. This makes it obvious that an acquisition has failed so that code that assumes success will terminate instead of potentially proceeding to corrupt user data. Since SRW locks do not fail due to resource exhaustion, the only such exception possible is `STATUS_RESOURCE_NOT_OWNED` in the case that a nonshared SRW lock is incorrectly being released in shared mode.

The Windows SRW locks do not prefer readers or writers, meaning that the performance for either case should be the same. This makes them great replacements for critical sections, which are writer-only or *exclusive* synchronization mechanisms, and they provide an optimized alternative to resources. If SRW locks were optimized for readers, they would be poor exclusive-only locks, but this isn't the case. This is why we earlier mentioned that conditional variables can also use SRW locks through the `SleepConditionVariableSRW` API. That being said, since keyed events are no longer used in one mechanism (SRW) but are still used in the other (CS), address-based waiting has muted most benefits other than code size—and the ability to have shared versus exclusive locking. Nevertheless, code targeting older versions of Windows should use SRW locks to guarantee the increased benefits are there on kernels that still used keyed events.

Run once initialization

The ability to guarantee the *atomic* execution of a piece of code responsible for performing some sort of initialization task—such as allocating memory, initializing certain variables, or even creating objects on demand—is a typical problem in multithreaded programming. In a piece of code that can be called simultaneously by multiple threads (a good example is the `DllMain` routine, which initializes a DLL), there are several ways of attempting to ensure the correct, atomic, and unique execution of initialization tasks.

For this scenario, Windows implements *init once*, or *one-time initialization* (also called *run once initialization* internally). The API exists both as a Win32 variant, which calls into `Ntdll.dll`'s Run Time Library (`Rtl`) as all the other previously seen mechanisms do, as well as the documented `Rtl` set of APIs, which are exposed to kernel programmers in `Ntoskrnl.exe` instead (obviously, user-mode developers could bypass Win32 and use the `Rtl` functions in `Ntdll.dll` too, but that is never recommended). The only difference between the two implementations is that the kernel ends up using an event object for synchronization, whereas user mode uses a keyed event instead (in fact, it passes in a NULL handle to use the low-memory keyed event that was previously used by critical sections).



Note Since recent versions of Windows now implement an address-based pushlock in kernel mode, as well as the address-based wait primitive in user mode, the `Rtl` library could probably be updated to use `RtlWakeAddressSingle` and `ExBlockOnAddressPushLock`, and in fact a future version of Windows could always do that—the keyed event merely provided a more similar interface to a dispatcher event object in older Windows versions. As always, do not rely on the internal details presented in this book, as they are subject to change.

The *init once* mechanism allows for both synchronous (meaning that the other threads must wait for initialization to complete) execution of a certain piece of code, as well as asynchronous (meaning that the other threads can attempt to do their own initialization and race) execution. We look at the logic behind asynchronous execution after explaining the synchronous mechanism.

In the synchronous case, the developer writes the piece of code that would normally execute after double-checking the global variable in a dedicated function. Any information that this routine needs can be passed through the *parameter* variable that the *init once* routine accepts. Any output information is returned through the *context* variable. (The status of the initialization itself is returned as a Boolean.) All the developer has to do to ensure proper execution is call *InitOnceExecuteOnce* with the *parameter*, *context*, and run-once function pointer after initializing an *INIT_ONCE* object with *InitOnceInitialize* API. The system takes care of the rest.

For applications that want to use the asynchronous model instead, the threads call *InitOnceBeginInitialize* and receive a BOOLEAN *pending status* and the *context* described earlier. If the *pending status* is *FALSE*, initialization has already taken place, and the thread uses the context value for the result. (It's also possible for the function to return *FALSE*, meaning that initialization failed.) However, if the pending status comes back as *TRUE*, the thread should *race* to be the first to create the object. The code that follows performs whatever initialization tasks are required, such as creating objects or allocating memory. When this work is done, the thread calls *InitOnceComplete* with the result of the work as the context and receives a BOOLEAN *status*. If the status is *TRUE*, the thread won the race, and the object that it created or allocated is the one that will be the global object. The thread can now save this object or return it to a caller, depending on the usage.

In the more complex scenario when the status is *FALSE*, this means that the thread lost the race. The thread must undo all the work it did, such as deleting objects or freeing memory, and then call *InitOnceBeginInitialize* again. However, instead of requesting to start a race as it did initially, it uses the *INIT_ONCE_CHECK_ONLY* flag, knowing that it has lost, and requests the winner's context instead (for example, the objects or memory that were created or allocated by the winner). This returns another *status*, which can be *TRUE*, meaning that the context is valid and should be used or returned to the caller, or *FALSE*, meaning that initialization failed and nobody has been able to perform the work (such as in the case of a low-memory condition, perhaps).

In both cases, the mechanism for run-once initialization is similar to the mechanism for condition variables and SRW locks. The *init once* structure is pointer-size, and inline assembly versions of the SRW acquisition/release code are used for the noncontended case, whereas keyed events are used when contention has occurred (which happens when the mechanism is used in synchronous mode) and the other threads must wait for initialization. In the asynchronous case, the locks are used in shared mode, so multiple threads can perform initialization at the same time. Although not as highly efficient as the alert-by-ID primitive, the usage of a keyed event still guarantees that the *init once* mechanism will function even in most cases of memory exhaustion.

Advanced local procedure call

All modern operating systems require a mechanism for securely and efficiently transferring data between one or more processes in user mode, as well as between a service in the kernel and clients in user mode. Typically, UNIX mechanisms such as mailslots, files, named pipes, and sockets are used for portability, whereas in other cases, developers can use OS-specific functionality, such as the ubiquitous window messages used in Win32 graphical applications. In addition, Windows also implements an internal IPC mechanism called Advanced (or Asynchronous) Local Procedure Call, or ALPC, which is a high-speed, scalable, and secured facility for message passing arbitrary-size messages.



Note ALPC is the replacement for an older IPC mechanism initially shipped with the very first kernel design of Windows NT, called LPC, which is why certain variables, fields, and functions might still refer to “LPC” today. Keep in mind that LPC is now emulated on top of ALPC for compatibility and has been removed from the kernel (legacy system calls still exist, which get wrapped into ALPC calls).

Although it is internal, and thus not available for third-party developers, ALPC is widely used in various parts of Windows:

- Windows applications that use remote procedure call (RPC), a documented API, indirectly use ALPC when they specify *local-RPC* over the *ncalrpc* transport, a form of RPC used to communicate between processes on the same system. This is now the default transport for almost all RPC clients. In addition, when Windows drivers leverage kernel-mode RPC, this implicitly uses ALPC as well as the only transport permitted.
- Whenever a Windows process and/or thread starts, as well as during any Windows subsystem operation, ALPC is used to communicate with the subsystem process (CSRSS). All subsystems communicate with the session manager (SMSS) over ALPC.
- When a Windows process raises an exception, the kernel’s exception dispatcher communicates with the Windows Error Reporting (WER) Service by using ALPC. Processes also can communicate with WER on their own, such as from the unhandled exception handler. (WER is discussed later in Chapter 10.)
- Winlogon uses ALPC to communicate with the local security authentication process, LSASS.
- The security reference monitor (an executive component explained in Chapter 7 of Part 1) uses ALPC to communicate with the LSASS process.
- The user-mode power manager and power monitor communicate with the kernel-mode power manager over ALPC, such as whenever the LCD brightness is changed.
- The User-Mode Driver Framework (UMDF) enables user-mode drivers to communicate with the kernel-mode reflector driver by using ALPC.

- The new Core Messaging mechanism used by CoreUI and modern UWP UI components use ALPC to both register with the Core Messaging Registrar, as well as to send serialized message objects, which replace the legacy Win32 window message model.
- The Isolated LSASS process, when Credential Guard is enabled, communicates with LSASS by using ALPC. Similarly, the Secure Kernel transmits trustlet crash dump information through ALPC to WER.
- As you can see from these examples, ALPC communication crosses all possible types of security boundaries—from unprivileged applications to the kernel, from VTL 1 trustlets to VTL 0 services, and everything in between. Therefore, security and performance were critical requirements in its design.

Connection model

Typically, ALPC messages are used between a server process and one or more client processes of that server. An ALPC connection can be established between two or more user-mode processes or between a kernel-mode component and one or more user-mode processes, or even between two kernel-mode components (albeit this would not be the most efficient way of communicating). ALPC exposes a single executive object called the *port object* to maintain the state needed for communication. Although this is just one object, there are several kinds of ALPC ports that it can represent:

- **Server connection port** A named port that is a server connection request point. Clients can connect to the server by connecting to this port.
- **Server communication port** An unnamed port a server uses to communicate with one of its clients. The server has one such port per active client.
- **Client communication port** An unnamed port each client uses to communicate with its server.
- **Unconnected communication port** An unnamed port a client can use to communicate locally with itself. This model was abolished in the move from LPC to ALPC but is emulated for Legacy LPC for compatibility reasons.

ALPC follows a connection and communication model that's somewhat reminiscent of BSD socket programming. A server first creates a server connection port (*NtAlpcCreatePort*), whereas a client attempts to connect to it (*NtAlpcConnectPort*). If the server was in a listening state (by using *NtAlpcSendWaitReceivePort*), it receives a connection request message and can choose to accept it (*NtAlpcAcceptConnectPort*). In doing so, both the client and server communication ports are created, and each respective endpoint process receives a handle to its communication port. Messages are then sent across this handle (still by using *NtAlpcSendWaitReceivePort*), which the server continues to receive by using the same API. Therefore, in the simplest scenario, a single server thread sits in a loop calling *NtAlpcSendWaitReceivePort* and receives with connection requests, which it accepts, or messages, which it handles and potentially responds to. The server can differentiate between messages by reading the *PORT_HEADER* structure, which sits on top of every message and contains a message type. The various message types are shown in Table 8-30.

TABLE 8-30 ALPC message types

Type	Meaning
<i>LPC_REQUEST</i>	A normal ALPC message, with a potential synchronous reply
<i>LPC_REPLY</i>	An ALPC message datagram, sent as an asynchronous reply to a previous datagram
<i>LPC_DATAGRAM</i>	An ALPC message datagram, which is immediately released and cannot be synchronously replied to
<i>LPC_LOST_REPLY</i>	Deprecated, used by Legacy LPC Reply API
<i>LPC_PORT_CLOSED</i>	Sent whenever the last handle of an ALPC port is closed, notifying clients and servers that the other side is gone
<i>LPC_CLIENT_DIED</i>	Sent by the process manager (<i>PspExitThread</i>) using Legacy LPC to the registered termination port(s) of the thread and the registered exception port of the process
<i>LPC_EXCEPTION</i>	Sent by the User-Mode Debugging Framework (<i>DbgkForwardException</i>) to the exception port through Legacy LPC
<i>LPC_DEBUG_EVENT</i>	Deprecated, used by the legacy user-mode debugging services when these were part of the Windows subsystem
<i>LPC_ERROR_EVENT</i>	Sent whenever a <i>hard error</i> is generated from user-mode (<i>NtRaiseHardError</i>) and sent using Legacy LPC to exception port of the target thread, if any, otherwise to the error port, typically owned by CSRSS
<i>LPC_CONNECTION_REQUEST</i>	An ALPC message that represents an attempt by a client to connect to the server's connection port
<i>LPC_CONNECTION_REPLY</i>	The internal message that is sent by a server when it calls <i>NtAlpcAcceptConnectPort</i> to accept a client's connection request
<i>LPC_CANCELED</i>	The received reply by a client or server that was waiting for a message that has now been canceled
<i>LPC_UNREGISTER_PROCESS</i>	Sent by the process manager when the exception port for the current process is swapped to a different one, allowing the owner (typically CSRSS) to unregister its data structures for the thread switching its port to a different one

The server can also deny the connection, either for security reasons or simply due to protocol or versioning issues. Because clients can send a custom payload with a connection request, this is usually used by various services to ensure that the correct client, or only one client, is talking to the server. If any anomalies are found, the server can reject the connection and, optionally, return a payload containing information on why the client was rejected (allowing the client to take corrective action, if possible, or for debugging purposes).

Once a connection is made, a connection information structure (actually, a *blob*, as we describe shortly) stores the linkage between all the different ports, as shown in Figure 8-40.

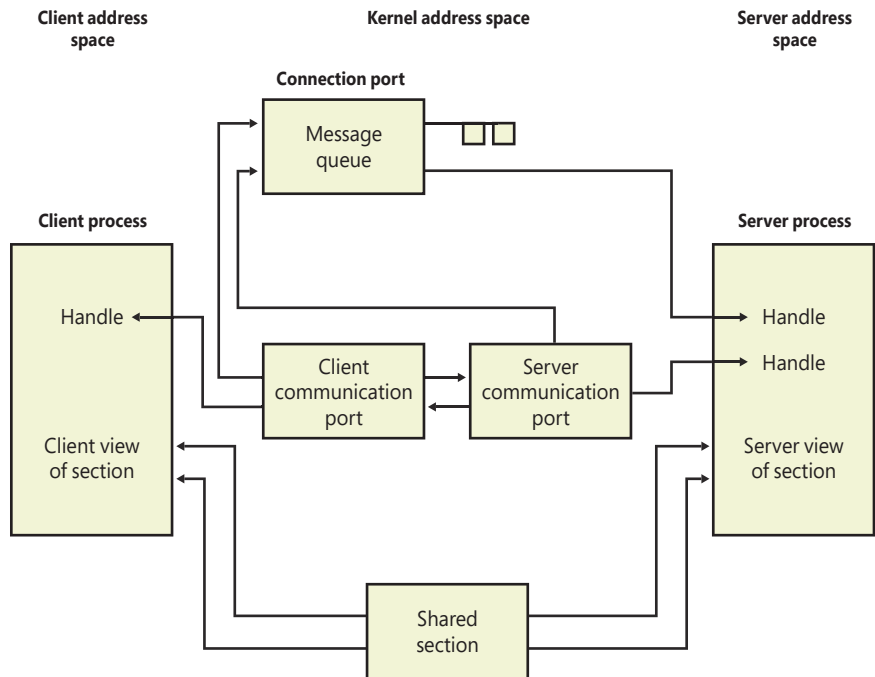

FIGURE 8-40 Use of ALPC ports.

Message model

Using ALPC, a client and thread using blocking messages each take turns performing a loop around the *NtAlpcSendWaitReceivePort* system call, in which one side sends a request and waits for a reply while the other side does the opposite. However, because ALPC supports asynchronous messages, it's possible for either side not to block and choose instead to perform some other runtime task and check for messages later (some of these methods will be described shortly). ALPC supports the following three methods of exchanging payloads sent with a message:

- A message can be sent to another process through the standard double-buffering mechanism, in which the kernel maintains a copy of the message (copying it from the source process), switches to the target process, and copies the data from the kernel's buffer. For compatibility, if legacy LPC is being used, only messages of up to 256 bytes can be sent this way, whereas ALPC can allocate an *extension buffer* for messages up to 64 KB.
- A message can be stored in an ALPC section object from which the client and server processes map views. (See Chapter 5 in Part 1 for more information on section mappings.)

An important side effect of the ability to send asynchronous messages is that a message can be canceled—for example, when a request takes too long or if the user has indicated that they want to cancel the operation it implements. ALPC supports this with the *NtAlpcCancelMessage* system call.

An ALPC message can be on one of five different queues implemented by the ALPC port object:

- **Main queue** A message has been sent, and the client is processing it.
- **Pending queue** A message has been sent and the caller is waiting for a reply, but the reply has not yet been sent.
- **Large message queue** A message has been sent, but the caller's buffer was too small to receive it. The caller gets another chance to allocate a larger buffer and request the message payload again.
- **Canceled queue** A message that was sent to the port but has since been canceled.
- **Direct queue** A message that was sent with a direct event attached.

Note that a sixth queue, called the *wait queue*, does not link messages together; instead, it links all the threads waiting on a message.

EXPERIMENT: Viewing subsystem ALPC port objects

You can see named ALPC port objects with the WinObj tool from Sysinternals or WinObjEx64 from GitHub. Run one of the two tools elevated as Administrator and select the root directory. A gear icon identifies the port objects in WinObj, and a power plug in WinObjEx64, as shown here (you can also click on the Type field to easily sort all the objects by their type):

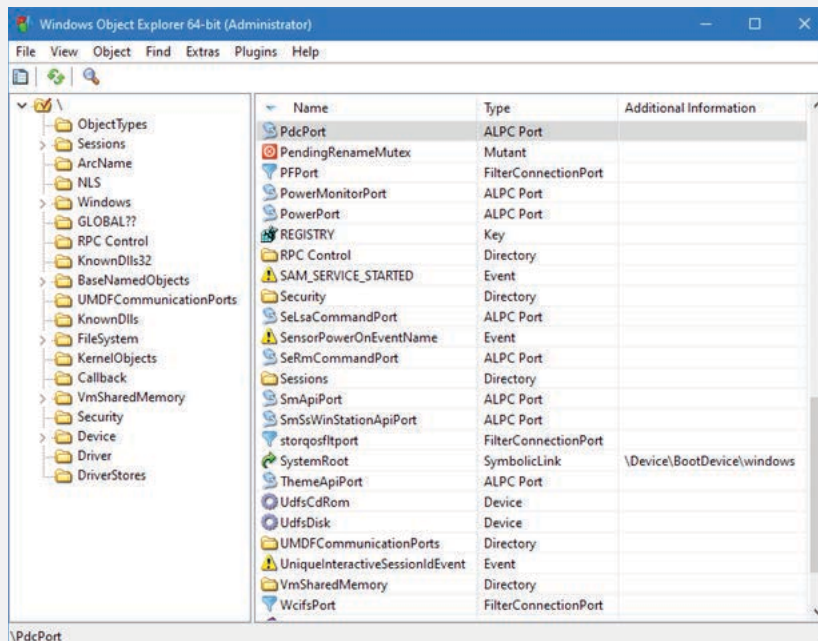

You should see the ALPC ports used by the power manager, the security manager, and other internal Windows services. If you want to see the ALPC port objects used by RPC, you can select the \RPC Control directory. One of the primary users of ALPC, outside of Local RPC, is the Windows subsystem, which uses ALPC to communicate with the Windows subsystem DLLs that are present in all Windows processes. Because CSRSS loads once for each session, you will find its ALPC port objects under the appropriate \Sessions\X\Windows directory, as shown here:

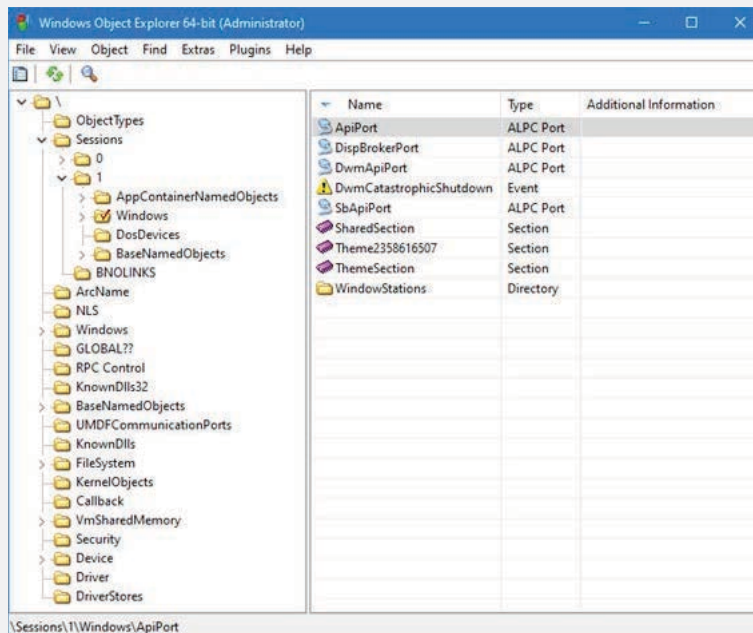

Asynchronous operation

The synchronous model of ALPC is tied to the original LPC architecture in the early NT design and is similar to other blocking IPC mechanisms, such as Mach ports. Although it is simple to design, a blocking IPC algorithm includes many possibilities for deadlock, and working around those scenarios creates complex code that requires support for a more flexible asynchronous (nonblocking) model. As such, ALPC was primarily designed to support asynchronous operation as well, which is a requirement for scalable RPC and other uses, such as support for pending I/O in user-mode drivers. A basic feature of ALPC, which wasn't originally present in LPC, is that blocking calls can have a timeout parameter. This allows legacy applications to avoid certain deadlock scenarios.

However, ALPC is optimized for asynchronous messages and provides three different models for asynchronous notifications. The first doesn't actually notify the client or server but simply copies the data payload. Under this model, it's up to the implementor to choose a reliable synchronization method. For example, the client and the server can share a notification event object, or the client can poll for data arrival. The data structure used by this model is the ALPC *completion list* (not to be confused with

the Windows I/O completion port). The ALPC completion list is an efficient, nonblocking data structure that enables atomic passing of data between clients, and its internals are described further in the upcoming “Performance” section.

The next notification model is a waiting model that uses the Windows completion-port mechanism (on top of the ALPC completion list). This enables a thread to retrieve multiple payloads at once, control the maximum number of concurrent requests, and take advantage of native completion-port functionality. The user-mode thread pool implementation provides internal APIs that processes use to manage ALPC messages within the same infrastructure as worker threads, which are implemented using this model. The RPC system in Windows, when using Local RPC (over *ncalrpc*), also makes use of this functionality to provide efficient message delivery by taking advantage of this kernel support, as does the kernel mode RPC runtime in *Msrpc.sys*.

Finally, because drivers can run in arbitrary context and typically do not like creating dedicated system threads for their operation, ALPC also provides a mechanism for a more basic, kernel-based notification using executive callback objects. A driver can register its own callback and context with *NtSetInformationAlpcPort*, after which it will get called whenever a message is received. The Power Dependency Coordinator (*Pdc.sys*) in the kernel employs this mechanism for communicating with its clients, for example. It’s worth noting that using an executive callback object has potential advantages—but also security risks—in terms of performance. Because the callbacks are executed in a blocking fashion (once signaled), and inline with the signaling code, they will always run in the context of an ALPC message sender (that is, inline with a user-mode thread calling *NtAlpcSendWaitReceivePort*). This means that the kernel component can have the chance to examine the state of its client without the cost of a context switch and can potentially consume the payload in the context of the sender.

The reason these are not absolute guarantees, however (and this becomes a risk if the implementor is unaware), is that multiple clients can send a message to the port at the same time and existing messages can be sent by a client before the server registers its executive callback object. It’s also possible for another client to send yet another message while the server is still processing the first message from a different client. In all these cases, the server will run in the context of *one* of the clients that sent a message but may be analyzing a message sent by a different client. The server should distinguish this situation (since the Client ID of the sender is encoded in the *PORT_HEADER* of the message) and attach/analyze the state of the correct sender (which now has a potential context switch cost).

Views, regions, and sections

Instead of sending message buffers between their two respective processes, a server and client can choose a more efficient data-passing mechanism that is at the core of the memory manager in Windows: the *section* object. (More information is available in Chapter 5 in Part 1.) This allows a piece of memory to be allocated as shared and for both client and server to have a consistent, and equal, view of this memory. In this scenario, as much data as can fit can be transferred, and data is merely copied into one address range and immediately available in the other. Unfortunately, shared-memory communication, such as LPC traditionally provided, has its share of drawbacks, especially when considering security ramifications. For one, because both client and server must have access to the shared memory, an unprivileged client can use this to corrupt the server’s shared memory and even build executable

payloads for potential exploits. Additionally, because the client knows the location of the server's data, it can use this information to bypass ASLR protections. (See Chapter 5 in Part 1 for more information.)

ALPC provides its own security on top of what's provided by section objects. With ALPC, a specific ALPC section object must be created with the appropriate *NtAlpcCreatePortSection* API, which creates the correct references to the port, as well as allows for automatic section garbage collection. (A manual API also exists for deletion.) As the owner of the ALPC section object begins using the section, the allocated chunks are created as ALPC regions, which represent a range of used addresses within the section and add an extra reference to the message. Finally, within a range of shared memory, the clients obtain views to this memory, which represents the local mapping within their address space.

Regions also support a couple of security options. First, regions can be mapped either using a secure mode or an unsecure mode. In the secure mode, only two views (mappings) are allowed to the region. This is typically used when a server wants to share data privately with a single client process. Additionally, only one region for a given range of shared memory can be opened from within the context of a given port. Finally, regions can also be marked with write-access protection, which enables only one process context (the server) to have write access to the view (by using *MmSecureVirtualMemoryAgainstWrites*). Other clients, meanwhile, will have read-only access only. These settings mitigate many privilege-escalation attacks that could happen due to attacks on shared memory, and they make ALPC more resilient than typical IPC mechanisms.

Attributes

ALPC provides more than simple message passing; it also enables specific contextual information to be added to each message and have the kernel track the validity, lifetime, and implementation of that information. Users of ALPC can assign their own custom context information as well. Whether it's system-managed or user-managed, ALPC calls this data *attributes*. There are seven attributes that the kernel manages:

- The security attribute, which holds key information to allow impersonation of clients, as well as advanced ALPC security functionality (which is described later).
- The data view attribute, responsible for managing the different views associated with the regions of an ALPC section. It is also used to set flags such as the auto-release flag, and when replying, to unmap a view manually.
- The context attribute, which allows user-managed context pointers to be placed on a port, as well as on a specific message sent across the port. In addition, a sequence number, message ID, and callback ID are stored here and managed by the kernel, which allows uniqueness, message-based hashing, and sequencing to be implemented by users of ALPC.
- The handle attribute, which contains information about which handles to associate with the message (which is described in more detail later in the "Handle passing" section).
- The token attribute, which can be used to get the Token ID, Authentication ID, and Modified ID of the message sender, without using a full-blown security attribute (but which does not, on its own, allow impersonation to occur).

- The direct attribute, which is used when sending direct messages that have a synchronization object associated with them (described later in the “Direct event” section).
- The work-on-behalf-of attribute, which is used to encode a work ticket used for better power management and resource management decisions (see the “Power management” section later).

Some of these attributes are initially passed in by the server or client when the message is sent and converted into the kernel’s own internal ALPC representation. If the ALPC user requests this data back, it is *exposed* back securely. In a few cases, a server or client can always request an attribute, because it is ALPC that internally associates it with a message and always makes it available (such as the context or token attributes). By implementing this kind of model and combining it with its own internal handle table, described next, ALPC can keep critical data opaque between clients and servers while still maintaining the true pointers in kernel mode.

To define attributes correctly, a variety of APIs are available for internal ALPC consumers, such as *AlpcInitializeMessageAttribute* and *AlpcGetMessageAttribute*.

Blobs, handles, and resources

Although the ALPC subsystem exposes only one Object Manager object type (the port), it internally must manage a number of data structures that allow it to perform the tasks required by its mechanisms. For example, ALPC needs to allocate and track the messages associated with each port, as well as the message attributes, which it must track for the duration of their lifetime. Instead of using the Object Manager’s routines for data management, ALPC implements its own lightweight objects called *blobs*. Just like objects, blobs can automatically be allocated and garbage collected, reference tracked, and locked through synchronization. Additionally, blobs can have custom allocation and deallocation callbacks, which let their owners control extra information that might need to be tracked for each blob. Finally, ALPC also uses the executive’s handle table implementation (used for objects and PIDs/TIDs) to have an ALPC-specific handle table, which allows ALPC to generate private handles for blobs, instead of using pointers.

In the ALPC model, messages are blobs, for example, and their constructor generates a message ID, which is itself a handle into ALPC’s handle table. Other ALPC blobs include the following:

- The connection blob, which stores the client and server communication ports, as well as the server connection port and ALPC handle table.
- The security blob, which stores the security data necessary to allow impersonation of a client. It stores the security attribute.
- The section, region, and view blobs, which describe ALPC’s shared-memory model. The view blob is ultimately responsible for storing the data view attribute.
- The reserve blob, which implements support for ALPC Reserve Objects. (See the “Reserve objects” section earlier in this chapter.)
- The handle data blob, which contains the information that enables ALPC’s handle attribute support.

Because blobs are allocated from pageable memory, they must carefully be tracked to ensure their deletion at the appropriate time. For certain kinds of blobs, this is easy: for example, when an ALPC message is freed, the blob used to contain it is also deleted. However, certain blobs can represent numerous attributes attached to a single ALPC message, and the kernel must manage their lifetime appropriately. For example, because a message can have multiple views associated with it (when many clients have access to the same shared memory), the views must be tracked with the messages that reference them. ALPC implements this functionality by using a concept of *resources*. Each message is associated with a resource list, and whenever a blob associated with a message (that isn't a simple pointer) is allocated, it is also added as a resource of the message. In turn, the ALPC library provides functionality for looking up, flushing, and deleting associated resources. Security blobs, reserve blobs, and view blobs are all stored as resources.

Handle passing

A key feature of Unix Domain Sockets and Mach ports, which are the most complex and most used IPC mechanisms on Linux and macOS, respectively, is the ability to send a message that encodes a *file descriptor* which will then be duplicated in the receiving process, granting it access to a UNIX-style file (such as a pipe, socket, or actual file system location). With ALPC, Windows can now also benefit from this model, with the handle attribute exposed by ALPC. This attribute allows a sender to encode an object type, some information about how to duplicate the handle, and the handle index in the table of the sender. If the handle index matches the type of object the sender is claiming to send, a duplicated handle is created, for the moment, in the system (kernel) handle table. This first part guarantees that the sender truly is sending what it is claiming, and that at this point, any operation the sender might undertake does not invalidate the handle or the object beneath it.

Next, the receiver requests exposing the handle attribute, specifying the type of object they expect. If there is a match, the kernel handle is duplicated once more, this time as a user-mode handle in the table of the receiver (and the kernel copy is now closed). The handle passing has been completed, and the receiver is guaranteed to have a handle to the exact same object the sender was referencing and of the type the receiver expects. Furthermore, because the duplication is done by the kernel, it means a privileged server can send a message to an unprivileged client without requiring the latter to have any type of access to the sending process.

This handle-passing mechanism, when first implemented, was primarily used by the Windows subsystem (CSRSS), which needs to be made aware of any child processes created by existing Windows processes, so that they can successfully connect to CSRSS when it is their turn to execute, with CSRSS already knowing about their creation from the parent. It had several issues, however, such as the inability to send more than a single handle (and certainly not more than one type of object). It also forced receivers to always receive any handle associated with a message on the port without knowing ahead of time if the message should have a handle associated with it to begin with.

To rectify these issues, Windows 8 and later now implement the *indirect handle* passing mechanism, which allows sending multiple handles of different types and allows receivers to manually retrieve handles on a per-message basis. If a port accepts and enables such indirect handles (non-RPC-based ALPC servers typically do not use indirect handles), handles will no longer be automatically duplicated based

on the handle attribute passed in when receiving a new message with *NtAlpcSendWaitReceivePort*—instead, ALPC clients and servers will have to manually query how many handles a given message contains, allocate sufficient data structures to receive the handle values and their types, and then request the duplication of all the handles, parsing the ones that match the expected types (while closing/dropping unexpected ones) by using *NtAlpcQueryInformationMessage* and passing in the received message.

This new behavior also introduces a security benefit—instead of handles being automatically duplicated as soon as the caller specifies a handle attribute with a matching type, they are only duplicated when requested on a per-message basis. Because a server might expect a handle for message A, but not necessarily for all other messages, nonindirect handles can be problematic if the server doesn't think of closing any possible handle even while parsing message B or C. With indirect handles, the server would never call *NtAlpcQueryInformationMessage* for such messages, and the handles would never be duplicated (or necessitate closing them).

Due to these improvements, the ALPC handle-passing mechanism is now exposed beyond just the limited use-cases described and is integrated with the RPC runtime and IDL compiler. It is now possible to use the `system_handle(sh_type)` syntax to indicate more than 20 different handle types that the RPC runtime can marshal from a client to a server (or vice-versa). Furthermore, although ALPC provides the type checking from the kernel's perspective, as described earlier, the RPC runtime itself also does additional type checking—for example, while both named pipes, sockets, and actual files are all "File Objects" (and thus handles of type "File"), the RPC runtime can do marshalling and unmarshalling checks to specifically detect whether a Socket handle is being passed when the IDL file indicates `system_handle(sh_pipe)`, for example (this is done by calling APIs such as *GetFileAttribute*, *GetDeviceType*, and so on).

This new capability is heavily leveraged by the AppContainer infrastructure and is the key way through which the WinRT API transfers handles that are opened by the various brokers (after doing capability checks) and duplicated back into the sandboxed application for direct use. Other RPC services that leverage this functionality include the DNS Client, which uses it to populate the *ai_resolutionhandle* field in the *GetAddrInfoEx* API.

Security

ALPC implements several security mechanisms, full security boundaries, and mitigations to prevent attacks in case of generic IPC parsing bugs. At a base level, ALPC port objects are managed by the same Object Manager interfaces that manage object security, preventing nonprivileged applications from obtaining handles to server ports with ACL. On top of that, ALPC provides a SID-based trust model, inherited from the original LPC design. This model enables clients to validate the server they are connecting to by relying on more than just the port name. With a secured port, the client process submits to the kernel the SID of the server process it expects on the side of the endpoint. At connection time, the kernel validates that the client is indeed connecting to the expected server, mitigating namespace squatting attacks where an untrusted server creates a port to spoof a server.

ALPC also allows both clients and servers to atomically and uniquely identify the thread and process responsible for each message. It also supports the full Windows impersonation model through the

NtAlpcImpersonateClientThread API. Other APIs give an ALPC server the ability to query the SIDs associated with all connected clients and to query the LUID (locally unique identifier) of the client's security token (which is further described in Chapter 7 of Part 1).

ALPC port ownership

The concept of port ownership is important to ALPC because it provides a variety of security guarantees to interested clients and servers. First and foremost, only the owner of an ALPC connection port can accept connections on the port. This ensures that if a port handle were to be somehow duplicated or inherited into another process, it would not be able to illegitimately accept incoming connections. Additionally, when handle attributes are used (direct or indirect), they are always duplicated in the context of the port owner process, regardless of who may be currently parsing the message.

These checks are highly relevant when a kernel component might be communicating with a client using ALPC—the kernel component may currently be attached to a completely different process (or even be operating as part of the System process with a system thread consuming the ALPC port messages), and knowledge of the port owner means ALPC does not incorrectly rely on the current process.

Conversely, however, it may be beneficial for a kernel component to arbitrarily accept incoming connections on a port regardless of the current process. One poignant example of this issue is when an executive callback object is used for message delivery. In this scenario, because the callback is synchronously called in the context of one or more sender processes, whereas the kernel connection port was likely created while executing in the System context (such as in *DriverEntry*), there would be a mismatch between the current process and the port owner process during the acceptance of the connection. ALPC provides a special port attribute flag—which only kernel callers can use—that marks a connection port as a *system port*; in such a case, the port owner checks are ignored.

Another important use case of port ownership is when performing server SID validation checks if a client has requested it, as was described in the “Security” section. This validation is always done by checking against the token of the owner of the connection port, regardless of who may be listening for messages on the port at this time.

Performance

ALPC uses several strategies to enhance performance, primarily through its support of completion lists, which were briefly described earlier. At the kernel level, a completion list is essentially a user Memory Descriptor List (MDL) that's been probed and locked and then mapped to an address. (For more information on MDLs, see Chapter 5 in Part 1.) Because it's associated with an MDL (which tracks physical pages), when a client sends a message to a server, the payload copy can happen directly at the physical level instead of requiring the kernel to double-buffer the message, as is common in other IPC mechanisms.

The completion list itself is implemented as a 64-bit queue of completed entries, and both user-mode and kernel-mode consumers can use an interlocked compare-exchange operation to insert and remove entries from the queue. Furthermore, to simplify allocations, once an MDL has been initialized, a bitmap is used to identify available areas of memory that can be used to hold new messages that are still being queued. The bitmap algorithm also uses native lock instructions on the processor to provide

atomic allocation and deallocation of areas of physical memory that can be used by completion lists. Completion lists can be set up with *NtAlpcSetInformationPort*.

A final optimization worth mentioning is that instead of copying data as soon as it is sent, the kernel sets up the payload for a delayed copy, capturing only the needed information, but without any copying. The message data is copied only when the receiver requests the message. Obviously, if shared memory is being used, there's no advantage to this method, but in asynchronous, kernel-buffer message passing, this can be used to optimize cancellations and high-traffic scenarios.

Power management

As we've seen previously, when used in constrained power environments, such as mobile platforms, Windows uses a number of techniques to better manage power consumption and processor availability, such as by doing heterogenous processing on architectures that support it (such as ARM64's big.LITTLE) and by implementing Connected Standby as a way to further reduce power on user systems when under light use.

To play nice with these mechanisms, ALPC implements two additional features: the ability for ALPC clients to push wake references onto their ALPC server's wake channel and the introduction of the Work On Behalf Of Attribute. The latter is an attribute that a sender can choose to associate with a message when it wants to associate the request with the current work ticket that it is associated with, or to create a new work ticket that describes the sending thread.

Such work tickets are used, for example, when the sender is currently part of a Job Object (either due to being in a Silo/Windows Container or by being part of a heterogenous scheduling system and/or Connected Standby system) and their association with a thread will cause various parts of the system to attribute CPU cycles, I/O request packets, disk/network bandwidth attribution, and energy estimation to be associated to the "behalf of" thread and not the acting thread.

Additionally, foreground priority donation and other scheduling steps are taken to avoid big.LITTLE priority inversion issues, where an RPC thread is stuck on the small core simply by virtue of being a background service. With a work ticket, the thread is forcibly scheduled on the big core and receives a foreground boost as a donation.

Finally, wake references are used to avoid deadlock situations when the system enters a *connected standby* (also called Modern Standby) state, as was described in Chapter 6 of Part 1, or when a UWP application is targeted for suspension. These references allow the lifetime of the process owning the ALPC port to be pinned, preventing the force suspend/deep freeze operations that the Process Lifetime Manager (PLM) would attempt (or the Power Manager, even for Win32 applications). Once the message has been delivered and processed, the wake reference can be dropped, allowing the process to be suspended if needed. (Recall that termination is not a problem because sending a message to a terminated process/closed port immediately wakes up the sender with a special *PORT_CLOSED* reply, instead of blocking on a response that will never come.)

ALPC direct event attribute

Recall that ALPC provides two mechanisms for clients and servers to communicate: *requests*, which are bidirectional, requiring a response, and *datagrams*, which are unidirectional and can never be synchronously replied to. A middle ground would be beneficial—a datagram-type message that cannot be replied to but whose receipt could be *acknowledged* in such a way that the sending party would know that the message was acted upon, without the complexity of having to implement response processing. In fact, this is what the *direct event* attribute provides.

By allowing a sender to associate a handle to a kernel event object (through *CreateEvent*) with the ALPC message, the direct event attribute captures the underlying *KEVENT* and adds a reference to it, tacking it onto the *KALPC_MESSAGE* structure. Then, when the receiving process gets the message, it can expose this direct event attribute and cause it to be signaled. A client could either have a Wait Completion Packet associated with an I/O completion port, or it could be in a synchronous wait call such as with *WaitForSingleObject* on the event handle and would now receive a notification and/or wait satisfaction, informing it of the message's successful delivery.

This functionality was previously manually provided by the RPC runtime, which allows clients calling *RpcAsynInitializeHandle* to pass in *RpcNotificationTypeEvent* and associate a *HANDLE* to an event object with an asynchronous RPC message. Instead of forcing the RPC runtime on the other side to respond to a *request* message, such that the RPC runtime on the sender's side would then signal the event locally to signal completion, ALPC now captures it into a Direct Event attribute, and the message is placed on a Direct Message Queue instead of the regular Message Queue. The ALPC subsystem will signal the message upon delivery, efficiently in kernel mode, avoiding an extra hop and context-switch.

Debugging and tracing

On checked builds of the kernel, ALPC messages can be logged. All ALPC attributes, blobs, message zones, and dispatch transactions can be individually logged, and undocumented **!alpc** commands in WinDbg can dump the logs. On retail systems, IT administrators and troubleshooters can enable the ALPC events of the NT kernel logger to monitor ALPC messages, (Event Tracing for Windows, also known as ETW, is discussed in Chapter 10.) ETW events do not include payload data, but they do contain connection, disconnection, and send/receive and wait/unblock information. Finally, even on retail systems, certain **!alpc** commands obtain information on ALPC ports and messages.

EXPERIMENT: Dumping a connection port

In this experiment, you use the CSRSS API port for Windows processes running in Session 1, which is the typical interactive session for the console user. Whenever a Windows application launches, it connects to CSRSS's API port in the appropriate session.

1. Start by obtaining a pointer to the connection port with the **!object** command:

```
Tkd> !object \Sessions\1\Windows\ApiPort
Object: ffff898f172b2df0 Type: (ffff898f032f9da0) ALPC Port
    ObjectHeader: ffff898f172b2dc0 (new version)
    HandleCount: 1 PointerCount: 7898
    Directory Object: fffffc704b10d9ce0 Name: ApiPort
```

2. Dump information on the port object itself with **!alpc /p**. This will confirm, for example, that CSRSS is the owner:

```
Tkd> !alpc /P ffff898f172b2df0
Port ffff898f172b2df0
    Type : ALPC_CONNECTION_PORT
    CommunicationInfo : fffffc704adf5d410
    ConnectionPort : ffff898f172b2df0 (ApiPort), Connections
    ClientCommunicationPort : 0000000000000000
    ServerCommunicationPort : 0000000000000000
    OwnerProcess : ffff898f17481140 (csrss.exe), Connections
    SequenceNo : 0x0023BE45 (2342469)
    CompletionPort : 0000000000000000
    CompletionList : 0000000000000000
    ConnectionPending : No
    ConnectionRefused : No
    Disconnected : No
    Closed : No
    FlushOnClose : Yes
    ReturnExtendedInfo : No
    Waitable : No
    Security : Static
    Wow64CompletionList : No
```

5 thread(s) are waiting on the port:

```
THREAD ffff898f3353b080 Cid 0288.2538 Teb: 00000090bce88000
Win32Thread: ffff898f340cde60 WAIT
THREAD ffff898f313aa080 Cid 0288.19ac Teb: 00000090bcf0e000
Win32Thread: ffff898f35584e40 WAIT
THREAD ffff898f191c3080 Cid 0288.060c Teb: 00000090bcff1000
Win32Thread: ffff898f17c5f570 WAIT
THREAD ffff898f174130c0 Cid 0288.0298 Teb: 00000090bcfd7000
Win32Thread: ffff898f173f6ef0 WAIT
THREAD ffff898f1b5e2080 Cid 0288.0590 Teb: 00000090bcfe9000
Win32Thread: ffff898f173f82a0 WAIT
THREAD ffff898f3353b080 Cid 0288.2538 Teb: 00000090bce88000
Win32Thread: ffff898f340cde60 WAIT
```

```
Main queue is empty.  
  
Direct message queue is empty.  
  
Large message queue is empty.  
  
Pending queue is empty.  
  
Canceled queue is empty.
```

3. You can see what clients are connected to the port, which includes all Windows processes running in the session, with the undocumented **!alpc /lpc** command, or, with a newer version of WinDbg, you can simply click the Connections link next to the ApiPort name. You will also see the server and client communication ports associated with each connection and any pending messages on any of the queues:

```
lkd> !alpc /lpc ffff898f082cbdf0  
  
ffff898f082cbdf0('ApiPort') 0, 131 connections  
ffff898f0b971940 0 ->ffff898f0868a680 0 ffff898f17479080('wininit.exe')  
ffff898f1741fdd0 0 ->ffff898f1742add0 0 ffff898f174ec240('services.exe')  
ffff898f1740cdd0 0 ->ffff898f17417dd0 0 ffff898f174da200('lsass.exe')  
ffff898f08272900 0 ->ffff898f08272dc0 0 ffff898f1753b400('svchost.exe')  
ffff898f08a702d0 0 ->ffff898f084d5980 0 ffff898f1753e3c0('svchost.exe')  
ffff898f081a3dc0 0 ->ffff898f08a70070 0 ffff898f175402c0('fontdrvhost.exe')  
ffff898f086dcde0 0 ->ffff898f17502de0 0 ffff898f17588440('svchost.exe')  
ffff898f1757abe0 0 ->ffff898f1757b980 0 ffff898f17c1a400('svchost.exe')
```

4. Note that if you have other sessions, you can repeat this experiment on those sessions also (as well as with session 0, the system session). You will eventually get a list of all the Windows processes on your machine.

Windows Notification Facility

The Windows Notification Facility, or WNF, is the core underpinning of a modern registrationless publisher/subscriber mechanism that was added in Windows 8 as a response to a number of architectural deficiencies when it came to notifying interested parties about the existence of some action, event, or state, and supplying a data payload associated with this state change.

To illustrate this, consider the following scenario: Service A wants to notify potential clients B, C, and D that the disk has been scanned and is safe for write access, as well as the number of bad sectors (if any) that were detected during the scan. There is no guarantee that B, C, D start after A—in fact, there’s a good chance they might start earlier. In this case, it is unsafe for them to continue their execution, and they should wait for A to execute and report the disk is safe for write access. But if A isn’t even running yet, how does one wait for it in the first place?

A typical solution would be for B to create an event “CAN_I_WAIT_FOR_A_YET” and then have A look for this event once started, create the “A_SAYS_DISK_IS_SAFE” event and then signal “CAN_I_WAIT_FOR_A_YET,” allowing B to know it’s now safe to wait for “A_SAYS_DISK_IS_SAFE”. In a single client scenario, this is feasible, but things become even more complex once we think about C and D, which might all be going through this same logic and could race the creation of the “CAN_I_WAIT_FOR_A_YET” event, at which point they would open the existing event (in our example, created by B) and wait on it to be signaled. Although this can be done, what guarantees that this event is truly created by B? Issues around malicious “squatting” of the name and denial of service attacks around the name now arise. Ultimately, a safe protocol can be designed, but this requires a lot of complexity for the developer(s) of A, B, C, and D—and we haven’t even discussed how to get the number of bad sectors.

WNF features

The scenario described in the preceding section is a common one in operating system design—and the correct pattern for solving it clearly shouldn’t be left to individual developers. Part of a job of an operating system is to provide simple, scalable, and performant solutions to common architectural challenges such as these, and this is what WNF aims to provide on modern Windows platforms, by providing:

- The ability to define a *state name* that can be subscribed to, or published to by arbitrary processes, secured by a standard Windows security descriptor (with a DACL and SACL)
- The ability to associate such a state name with a payload of up to 4 KB, which can be retrieved along with the subscription to a change in the state (and published with the change)
- The ability to have *well-known state names* that are provisioned with the operating system and do not need to be created by a publisher while potentially racing with consumers—thus consumers will block on the state change notification even if a publisher hasn’t started yet
- The ability to *persist state data* even between reboots, such that consumers may be able to see previously published data, even if they were not yet running
- The ability to assign *state change timestamps* to each state name, such that consumers can know, even across reboots, if new data was published at some point without the consumer being active (and whether to bother acting on previously published data)
- The ability to assign *scope* to a given state name, such that multiple instances of the same state name can exist either within an interactive session ID, a server silo (container), a given user token/SID, or even within an individual process.
- Finally, the ability to do all of the publishing and consuming of WNF state names while crossing the kernel/user boundary, such that components can interact with each other on either side.

WNF users

As the reader can tell, providing all these semantics allows for a rich set of services and kernel components to leverage WNF to provide notifications and other state change signals to hundreds of clients (which could be as fine-grained as individual APIs in various system libraries to large scale processes). In fact, several key system components and infrastructure now use WNF, such as

- The Power Manager and various related components use WNF to signal actions such as closing and opening the lid, battery charging state, turning the monitor off and on, user presence detection, and more.
- The Shell and its components use WNF to track application launches, user activity, lock screen behavior, taskbar behavior, Cortana usage, and Start menu behavior.
- The System Events Broker (SEB) is an entire infrastructure that is leveraged by UWP applications and brokers to receive notifications about system events such as the audio input and output.
- The Process Manager uses per-process temporary WNF state names to implement the *wake channel* that is used by the Process Lifetime Manager (PLM) to implement part of the mechanism that allows certain events to force-wake processes that are marked for suspension (deep freeze).

Enumerating all users of WNF would take up this entire book because more than 6000 different well-known state names are used, in addition to the various temporary names that are created (such as the per-process wake channels). However, a later experiment showcases the use of the *wnf_dump* utility part of the book tools, which allows the reader to enumerate and interact with all of their system's WNF events and their data. The Windows Debugging Tools also provide a *!wnf* extension that is shown in a future experiment and can also be used for this purpose. Meanwhile, the Table 8-31 explains some of the key WNF state name prefixes and their uses. You will encounter many Windows components and codenames across a vast variety of Windows SKUs, from Windows Phone to XBOX, exposing the richness of the WNF mechanism and its pervasiveness.

TABLE 8-31 WNF state name prefixes

Prefix	# of Names	Usage
9P	2	Plan 9 Redirector
A2A	1	App-to-App
AAD	2	Azure Active Directory
AA	3	Assigned Access
ACC	1	Accessibility
ACHK	1	Boot Disk Integrity Check (Autochk)
ACT	1	Activity
AFD	1	Ancillary Function Driver (Winsock)
AI	9	Application Install
AOW	1	Android-on-Windows (Deprecated)
ATP	1	Microsoft Defender ATP

Prefix	# of Names	Usage
AUDC	15	Audio Capture
AVA	1	Voice Activation
AVLC	3	Volume Limit Change
BCST	1	App Broadcast Service
BI	16	Broker Infrastructure
BLTH	14	Bluetooth
BMP	2	Background Media Player
BOOT	3	Boot Loader
BRI	1	Brightness
BSC	1	Browser Configuration (Legacy IE, Deprecated)
CAM	66	Capability Access Manager
CAPS	1	Central Access Policies
CCTL	1	Call Control Broker
CDP	17	Connected Devices Platform (Project "Rome"/Application Handoff)
CELL	78	Cellular Services
CERT	2	Certificate Cache
CFCL	3	Flight Configuration Client Changes
CI	4	Code Integrity
CLIP	6	Clipboard
CMFC	1	Configuration Management Feature Configuration
CMPT	1	Compatibility
CNET	10	Cellular Networking (Data)
CONT	1	Containers
CSC	1	Client Side Caching
CSHL	1	Composable Shell
CSH	1	Custom Shell Host
CXH	6	Cloud Experience Host
DBA	1	Device Broker Access
DCSP	1	Diagnostic Log CSP
DEP	2	Deployment (Windows Setup)
DEVM	3	Device Management
DICT	1	Dictionary
DISK	1	Disk
DISP	2	Display
DMF	4	Data Migration Framework

Prefix	# of Names	Usage
DNS	1	DNS
DO	2	Delivery Optimization
DSM	2	Device State Manager
DUMP	2	Crash Dump
DUSM	2	Data Usage Subscription Management
DWM	9	Desktop Window Manager
DXGK	2	DirectX Kernel
DX	24	DirectX
EAP	1	Extensible Authentication Protocol
EDGE	4	Edge Browser
EDP	15	Enterprise Data Protection
EDU	1	Education
EFS	2	Encrypted File Service
EMS	1	Emergency Management Services
ENTR	86	Enterprise Group Policies
EOA	8	Ease of Access
ETW	1	Event Tracing for Windows
EXEC	6	Execution Components (Thermal Monitoring)
FCON	1	Feature Configuration
FDBK	1	Feedback
FLTN	1	Flighting Notifications
FLT	2	Filter Manager
FLYT	1	Flight ID
FOD	1	Features on Demand
FSRL	2	File System Runtime (FsRtl)
FVE	15	Full Volume Encryption
GC	9	Game Core
GIP	1	Graphics
GLOB	3	Globalization
GPOL	2	Group Policy
HAM	1	Host Activity Manager
HAS	1	Host Attestation Service
HOLO	32	Holographic Services
HPM	1	Human Presence Manager
HVL	1	Hypervisor Library (Hvl)

Prefix	# of Names	Usage
HYPV	2	Hyper-V
IME	4	Input Method Editor
IMSN	7	Immersive Shell Notifications
IMS	1	Entitlements
INPUT	5	Input
IOT	2	Internet of Things
ISM	4	Input State Manager
IUIS	1	Immersive UI Scale
KSR	2	Kernel Soft Reboot
KSV	5	Kernel Streaming
LANG	2	Language Features
LED	1	LED Alert
LFS	12	Location Framework Service
LIC	9	Licensing
LM	7	License Manager
LOC	3	Geolocation
LOGN	8	Logon
MAPS	3	Maps
MBAE	1	MBAE
MM	3	Memory Manager
MON	1	Monitor Devices
MRT	5	Microsoft Resource Manager
MSA	7	Microsoft Account
MSHL	1	Minimal Shell
MUR	2	Media UI Request
MU	1	Unknown
NASV	5	Natural Authentication Service
NCB	1	Network Connection Broker
NDIS	2	Kernel NDIS
NFC	1	Near Field Communication (NFC) Services
NGC	12	Next Generation Crypto
NLA	2	Network Location Awareness
NLM	6	Network Location Manager
NLS	4	Nationalization Language Services

Prefix	# of Names	Usage
NPSM	1	Now Playing Session Manager
NSI	1	Network Store Interface Service
OLIC	4	OS Licensing
OOBE	4	Out-Of-Box-Experience
OSWN	8	OS Storage
OS	2	Base OS
OVRD	1	Window Override
PAY	1	Payment Broker
PDM	2	Print Device Manager
PFG	2	Pen First Gesture
PHNL	1	Phone Line
PHNP	3	Phone Private
PHN	2	Phone
PMEM	1	Persistent Memory
PNPA-D	13	Plug-and-Play Manager
PO	54	Power Manager
PROV	6	Runtime Provisioning
PS	1	Kernel Process Manager
PTI	1	Push to Install Service
RDR	1	Kernel SMB Redirector
RM	3	Game Mode Resource Manager
RPCF	1	RPC Firewall Manager
RTDS	2	Runtime Trigger Data Store
RTSC	2	Recommended Troubleshooting Client
SBS	1	Secure Boot State
SCH	3	Secure Channel (SChannel)
SCM	1	Service Control Manager
SDO	1	Simple Device Orientation Change
SEB	61	System Events Broker
SFA	1	Secondary Factor Authentication
SHEL	138	Shell
SHR	3	Internet Connection Sharing (ICS)
SIDX	1	Search Indexer
SIO	2	Sign-In Options

Prefix	# of Names	Usage
SYKD	2	SkyDrive (Microsoft OneDrive)
SMSR	3	SMS Router
SMSS	1	Session Manager
SMS	1	SMS Messages
SPAC	2	Storage Spaces
SPCH	4	Speech
SPI	1	System Parameter Information
SPLT	4	Servicing
SRC	1	System Radio Change
SRP	1	System Replication
SRT	1	System Restore (Windows Recovery Environment)
SRUM	1	Sleep Study
SRV	2	Server Message Block (SMB/CIFS)
STOR	3	Storage
SUPP	1	Support
SYNC	1	Phone Synchronization
SYS	1	System
TB	1	Time Broker
TEAM	4	TeamOS Platform
TEL	5	Microsoft Defender ATP Telemetry
TETH	2	Tethering
THME	1	Themes
TKBN	24	Touch Keyboard Broker
TKBR	3	Token Broker
TMCN	1	Tablet Mode Control Notification
TOPE	1	Touch Event
TPM	9	Trusted Platform Module (TPM)
TZ	6	Time Zone
UBPM	4	User Mode Power Manager
UDA	1	User Data Access
UDM	1	User Device Manager
UMDF	2	User Mode Driver Framework
UMGR	9	User Manager
USB	8	Universal Serial Bus (USB) Stack

Prefix	# of Names	Usage
USO	16	Update Orchestrator
UTS	2	User Trusted Signals
UUS	1	Unknown
UWF	4	Unified Write Filter
VAN	1	Virtual Area Networks
VPN	1	Virtual Private Networks
VTSV	2	Vault Service
WAAS	2	Windows-as-a-Service
WBIO	1	Windows Biometrics
WCDS	1	Wireless LAN
WCM	6	Windows Connection Manager
WDAG	2	Windows Defender Application Guard
WDSC	1	Windows Defender Security Settings
WEBA	2	Web Authentication
WER	3	Windows Error Reporting
WFAS	1	Windows Firewall Application Service
WFDN	3	WiFi Display Connect (MiraCast)
WFS	5	Windows Family Safety
WHTP	2	Windows HTTP Library
WIFI	15	Windows Wireless Network (WiFi) Stack
WIL	20	Windows Instrumentation Library
WNS	1	Windows Notification Service
WOF	1	Windows Overlay Filter
WOSC	9	Windows One Setting Configuration
WPN	5	Windows Push Notifications
WSC	1	Windows Security Center
WSL	1	Windows Subsystem for Linux
WSQM	1	Windows Software Quality Metrics (SQM)
WUA	6	Windows Update
WWAN	5	Wireless Wire Area Network (WWAN) Service
XBOX	116	XBOX Services

WNF state names and storage

WNF state names are represented as random-looking 64-bit identifiers such as 0xAC41491908517835 and then defined to a friendly name using C preprocessor macros such as `WNF_AUDC_CAPTURE_ACTIVE`. In reality, however, these numbers are used to encode a version number (1), a lifetime (persistent versus temporary), a scope (process-instanced, container-instanced, user-instanced, session-instanced, or machine-instanced), a permanent data flag, and, for well-known state names, a prefix identifying the owner of the state name followed by a unique sequence number. Figure 8-41 below shows this format.

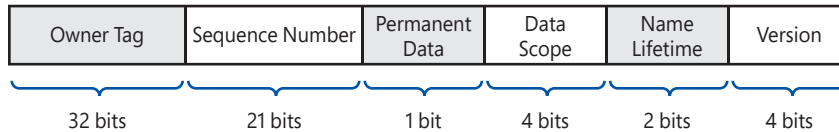

FIGURE 8-41 Format of a WNF state name.

As mentioned earlier, state names can be *well-known*, which means that they are preprovisioned for arbitrary out-of-order use. WNF achieves this by using the registry as a backing store, which will encode the security descriptor, maximum data size, and type ID (if any) under the `HKLM\SYSTEM\CurrentControlSet\Control\Notifications` registry key. For each state name, the information is stored under a value matching the 64-bit encoded WNF state name identifier.

Additionally, WNF state names can also be registered as *persistent*, meaning that they will remain registered for the duration of the system's uptime, regardless of the registrar's process lifetime. This mimics permanent objects that were shown in the "Object Manager" section of this chapter, and similarly, the `SeCreatePermanentPrivilege` privilege is required to register such state names. These WNF state names also live in the registry, but under the `HKLM\SOFTWARE\Microsoft\Windows NT\CurrentVersion\VolatileNotifications` key, and take advantage of the registry's volatile flag to simply disappear once the machine is rebooted. You might be confused to see "volatile" registry keys being used for "persistent" WNF data—keep in mind that, as we just indicated, the persistence here is within a boot session (versus attached to process lifetime, which is what WNF calls temporary, and which we'll see later).

Furthermore, a WNF state name can be registered as *permanent*, which endows it with the ability to persist even across reboots. This is the type of "persistence" you may have been expecting earlier. This is done by using yet another registry key, this time without the volatile flag set, present at `HKLM\SOFTWARE\Microsoft\Windows NT\CurrentVersion\Notifications`. Suffice it to say, the `SeCreatePermanentPrivilege` is needed for this level of persistence as well. For these types of WNF states, there is an additional registry key found below the hierarchy, called `Data`, which contains, for each 64-bit encoded WNF state name identifier, the last change stamp, and the binary data. Note that if the WNF state name was never written to on your machine, the latter information might be missing.

Experiment: View WNF state names and data in the registry

In this experiment, you use the Registry Editor to take a look at the well-known WNF names as well as some examples of permanent and persistent names. By looking at the raw binary registry data, you will be able to see the data and security descriptor information.

Open Registry Editor and navigate to the HKEY_LOCAL_MACHINE\SYSTEM\CurrentControlSet\Control\Notifications key.

Take a look at the values you see, which should look like the screenshot below.

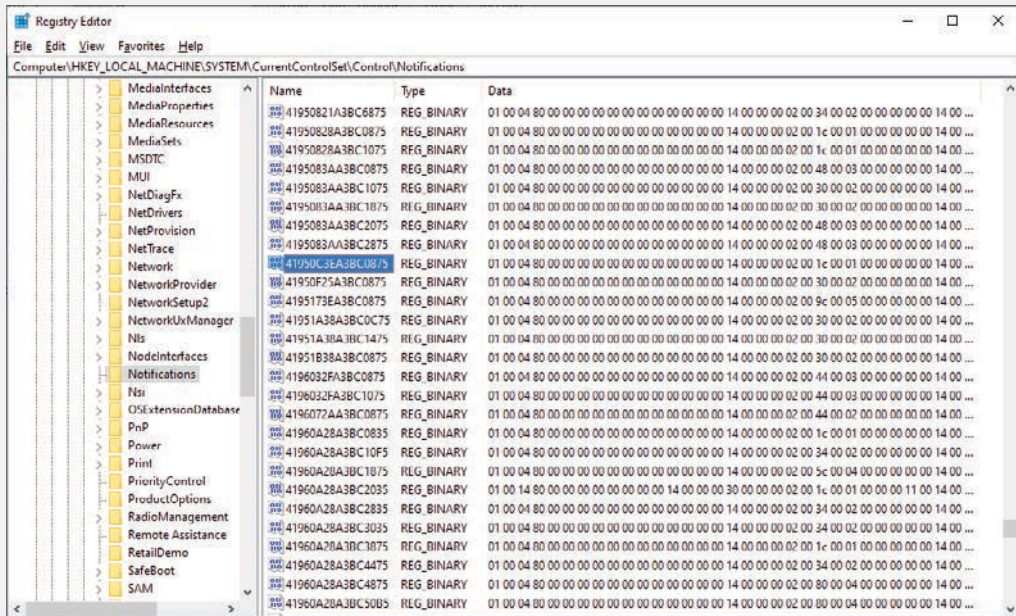

Double-click the value called 41950C3EA3BC0875 (WNF_SBS_UPDATE_AVAILABLE), which opens the raw registry data binary editor.

Note how in the following figure, you can see the security descriptor (the highlighted binary data, which includes the SID S-1-5-18), as well as the maximum data size (0 bytes).

Second, and related to this fact, no registry keys are used to encode temporary state names—they are tied to the process that registered a given instance of a state name, and all the data is stored in kernel pool only. These types of names, for example, are used to implement the per-process wake channels described earlier. Other uses include power manager notifications, and direct service triggers used by the SCM.

WNF publishing and subscription model

When publishers leverage WNF, they do so by following a standard pattern of registering the state name (in the case of non-well-known state names) and publishing some data that they want to expose. They can also choose not to publish any data but simply provide a 0-byte buffer, which serves as a way to “light up” the state and signals the subscribers anyway, even though no data was stored.

Consumers, on the other hand, use WNF’s registration capabilities to associate a callback with a given WNF state name. Whenever a change is published, this callback is activated, and, for kernel mode, the caller is expected to call the appropriate WNF API to retrieve the data associated with the state name. (The buffer size is provided, allowing the caller to allocate some pool, if needed, or perhaps choose to use the stack.) For user mode, on the other hand, the underlying WNF notification mechanism inside of Ntdll.dll takes care of allocating a heap-backed buffer and providing a pointer to this data directly to the callback registered by the subscriber.

In both cases, the callback also provides the change stamp, which acts as a unique monotonic sequence number that can be used to detect missed published data (if a subscriber was inactive, for some reason, and the publisher continued to produce changes). Additionally, a custom context can be associated with the callback, which is useful in C++ situations to tie the static function pointer to its class.



Note WNF provides an API for querying whether a given WNF state name has been registered yet (allowing a consumer to implement special logic if it detects the producer must not yet be active), as well as an API for querying whether there are any subscriptions currently active for a given state name (allowing a publisher to implement special logic such as perhaps delaying additional data publication, which would override the previous state data).

WNF manages what might be thousands of subscriptions by associating a data structure with each kernel and/or user-mode subscription and tying all the subscriptions for a given WNF state name together. This way, when a state name is published to, the list of subscriptions is parsed, and, for user mode, a delivery payload is added to a linked list followed by the signaling of a per-process notification event—this instructs the WNF delivery code in Ntdll.dll to call the API to consume the payload (and any other additional delivery payloads that were added to the list in the meantime). For kernel mode, the mechanism is simpler—the callback is synchronously executed in the context of the publisher.

Note that it’s also possible to subscribe to notifications in two modes: *data*-notification mode, and *meta*-notification mode. The former does what one might expect—executing the callback when new data has been associated with a WNF state name. The latter is more interesting because it sends notifications when a new consumer has become active or inactive, as well as when a publisher has terminated (in the case of a volatile state name, where such a concept exists).

Finally, it's worth pointing out that user-mode subscriptions have an additional wrinkle: Because Ntdll.dll manages the WNF notifications for the entire process, it's possible for multiple components (such as dynamic libraries/DLLs) to have requested their own callback for the same WNF state name (but for different reasons and with different contexts). In this situation, the Ntdll.dll library needs to associate registration contexts with each module, so that the per-process delivery payload can be translated into the appropriate callback and only delivered if the requested delivery mode matches the notification type of the subscriber.

Experiment: Using the WnfDump utility to dump WNF state names

In this experiment, you use one of the book tools (WnfDump) to register a WNF subscription to the `WNF_SHEL_DESKTOP_APPLICATION_STARTED` state name and the `WNF_AUDC_RENDER` state name.

Execute **wnfDump** on the command line with the following flags:

```
-i WNF_SHEL_DESKTOP_APPLICATION_STARTED -v
```

The tool displays information about the state name and reads its data, such as shown in the following output:

```
C:\>wnfdump.exe -i WNF_SHEL_DESKTOP_APPLICATION_STARTED -v
WNF State Name                               | S | L | P | AC | N | CurSize | MaxSize
-----
WNF_SHEL_DESKTOP_APPLICATION_STARTED         | S | W | N | RW | I |      28 |     512
65 00 3A 00 6E 00 6F 00-74 00 65 00 70 00 61 00 e...n.o.t.e.p.a.
64 00 2E 00 65 00 78 00-65 00 00 00          d...e.x.e...
```

Because this event is associated with Explorer (the shell) starting desktop applications, you will see one of the last applications you double-clicked, used the Start menu or Run menu for, or, in general, anything that the *ShellExecute* API was used on. The change stamp is also shown, which will end up a counter of how many desktop applications have been started this way since booting this instance of Windows (as this is a *persistent*, but not *permanent*, event).

Launch a new desktop application such as Paint by using the Start menu and try the **wnfDump** command again. You should see the change stamp incremented and new binary data shown.

WNF event aggregation

Although WNF on its own provides a powerful way for clients and services to exchange state information and be notified of each other's statuses, there may be situations where a given client/subscriber is interested in more than a single WNF state name.

For example, there may be a WNF state name that is published whenever the screen backlight is off, another when the wireless card is powered off, and yet another when the user is no longer physically present. A subscriber may want to be notified when *all* of these WNF state names have

been published—yet another may require a notification when either the first two *or* the latter has been published.

Unfortunately, the WNF system calls and infrastructure provided by Ntdll.dll to user-mode clients (and equally, the API surface provided by the kernel) only operate on single WNF state names. Therefore, the kinds of examples given would require manual handling through a state machine that each subscriber would need to implement.

To facilitate this common requirement, a component exists both in user mode as well as in kernel mode that handles the complexity of such a state machine and exposes a simple API: the Common Event Aggregator (CEA) implemented in CEA.SYS for kernel-mode callers and EventAggregation.dll for user-mode callers. These libraries export a set of APIs (such as *EaCreateAggregatedEvent* and *EaSignalAggregatedEvent*), which allow an interrupt-type behavior (a *start* callback while a WNF state is true, and a *stop* callback once the WNF state is false) as well as the combination of conditions with operators such as AND, OR, and NOT.

Users of CEA include the USB Stack as well as the Windows Driver Foundation (WDF), which exposes a framework callback for WNF state name changes. Further, the Power Delivery Coordinator (Pdc.sys) uses CEA to build power state machines like the example at the beginning of this subsection. The Unified Background Process Manager (UBPM) described in Chapter 9 also relies on CEA to implement capabilities such as starting and stopping services based on low power and/or idle conditions.

Finally, WNF is also integral to a service called the System Event Broker (SEB), implemented in SystemEventsBroker.dll and whose client library lives in SystemEventsBrokerClient.dll. The latter exports APIs such as *SebRegisterPrivateEvent*, *SebQueryEventData*, and *SebSignalEvent*, which are then passed through an RPC interface to the service. In user mode, SEB is a cornerstone of the Universal Windows Platform (UWP) and the various APIs that interrogate system state, and services that trigger themselves based on certain state changes that WNF exposes. Especially on OneCore-derived systems such as Windows Phone and XBOX (which, as was shown earlier, make up more than a few hundred of the well-known WNF state names), SEB is a central powerhouse of system notification capabilities, replacing the legacy role that the Window Manager provided through messages such as *WM_DEVICEARRIVAL*, *WM_SESSIONENDCHANGE*, *WM_POWER*, and others.

SEB pipes into the Broker Infrastructure (BI) used by UWP applications and allows applications, even when running under an AppContainer, to access WNF events that map to systemwide state. In turn, for WinRT applications, the *Windows.ApplicationModel.Background* namespace exposes a *SystemTrigger* class, which implements *IBackgroundTrigger*, that pipes into the SEB's RPC services and C++ API, for certain well-known system events, which ultimately transforms to *WNF_SEB_XXX* event state names. It serves as a perfect example of how something highly undocumented and internal, such as WNF, can ultimately be at the heart of a high-level documented API for Modern UWP application development. SEB is only one of the many brokers that UWP exposes, and at the end of the chapter, we cover background tasks and the Broker Infrastructure in full detail.

User-mode debugging

Support for user-mode debugging is split into three different modules. The first one is located in the executive itself and has the prefix *Dbgk*, which stands for *Debugging Framework*. It provides the necessary internal functions for registering and listening for debug events, managing the debug object, and packaging the information for consumption by its user-mode counterpart. The user-mode component that talks directly to *Dbgk* is located in the native system library, *Ntdll.dll*, under a set of APIs that begin with the prefix *DbgUi*. These APIs are responsible for wrapping the underlying debug object implementation (which is opaque), and they allow all subsystem applications to use debugging by wrapping their own APIs around the *DbgUi* implementation. Finally, the third component in user-mode debugging belongs to the subsystem DLLs. It is the exposed, documented API (located in *KernelBase.dll* for the Windows subsystem) that each subsystem supports for performing debugging of other applications.

Kernel support

The kernel supports user-mode debugging through an object mentioned earlier: the *debug* object. It provides a series of system calls, most of which map directly to the Windows debugging API, typically accessed through the *DbgUi* layer first. The debug object itself is a simple construct, composed of a series of flags that determine state, an event to notify any waiters that debugger events are present, a doubly linked list of debug events waiting to be processed, and a fast mutex used for locking the object. This is all the information that the kernel requires for successfully receiving and sending debugger events, and each debugged process has a *debug port* member in its executive process structure pointing to this debug object.

Once a process has an associated debug port, the events described in Table 8-32 can cause a debug event to be inserted into the list of events.

Apart from the causes mentioned in the table, there are a couple of special triggering cases outside the regular scenarios that occur at the time a debugger object first becomes associated with a process. The first *create process* and *create thread* messages will be manually sent when the debugger is attached, first for the process itself and its main thread and followed by create thread messages for all the other threads in the process. Finally, *load dll* events for the executable being debugged, starting with *Ntdll.dll* and then all the current DLLs loaded in the debugged process will be sent. Similarly, if a debugger is already attached, but a cloned process (fork) is created, the same events will also be sent for the first thread in the clone (as instead of just *Ntdll.dll*, all other DLLs are also present in the cloned address space).

There also exists a special flag that can be set on a thread, either during creation or dynamically, called *hide from debugger*. When this flag is turned on, which results in the *HideFromDebugger* flag in the TEB to be set, all operations done by the current thread, even if the debug port has a debug port, will not result in a debugger message.

TABLE 8-32 Kernel-mode debugging events

Event Identifier	Meaning	Triggered By
<i>DbgKmExceptionApi</i>	An exception has occurred.	<i>KiDispatchException</i> during an exception that occurred in user mode.
<i>DbgKmCreateThreadApi</i>	A new thread has been created.	Startup of a user-mode thread.
<i>DbgKmCreateProcessApi</i>	A new process has been created.	Startup of a user-mode thread that is the first thread in the process, if the <i>CreateReported</i> flag is not already set in <i>EPROCESS</i> .
<i>DbgKmExitThreadApi</i>	A thread has exited.	Death of a user-mode thread, if the <i>ThreadInserted</i> flag is set in <i>ETHREAD</i> .
<i>DbgKmExitProcessApi</i>	A process has exited.	Death of a user-mode thread that was the last thread in the process, if the <i>ThreadInserted</i> flag is set in <i>ETHREAD</i> .
<i>DbgKmLoadDllApi</i>	A DLL was loaded.	<i>NtMapViewOfSection</i> when the section is an image file (could be an EXE as well), if the <i>SuppressDebugMsg</i> flag is not set in the TEB.
<i>DbgKmUnloadDllApi</i>	A DLL was unloaded.	<i>NtUnmapViewOfSection</i> when the section is an image file (could be an EXE as well), if the <i>SuppressDebugMsg</i> flag is not set in the TEB.
<i>DbgKmErrorReportApi</i>	A user-mode exception must be forwarded to WER.	<i>This special case message is sent over ALPC, not the debug object, if the <i>DbgKmExceptionApi</i> message returned <i>DBG_EXCEPTION_NOT_HANDLED</i>, so that WER can now take over exception processing.</i>

Once a debugger object has been associated with a process, the process enters the *deep freeze* state that is also used for UWP applications. As a reminder, this suspends all threads and prevents any new remote thread creation. At this point, it is the debugger’s responsibility to start requesting that debug events be sent through. Debuggers usually request that debug events be sent back to user mode by performing a *wait* on the debug object. This call loops the list of debug events. As each request is removed from the list, its contents are converted from the internal *DBGK* structure to the *native* structure that the next layer up understands. As you’ll see, this structure is different from the Win32 structure as well, and another layer of conversion has to occur. Even after all pending debug messages have been processed by the debugger, the kernel does not automatically resume the process. It is the debugger’s responsibility to call the *ContinueDebugEvent* function to resume execution.

Apart from some more complex handling of certain multithreading issues, the basic model for the framework is a simple matter of *producers*—code in the kernel that generates the debug events in the previous table—and *consumers*—the debugger waiting on these events and acknowledging their receipt.

Native support

Although the basic protocol for user-mode debugging is quite simple, it’s not directly usable by Windows applications—instead, it’s wrapped by the *DbgUi* functions in *Ntdll.dll*. This abstraction is required to allow native applications, as well as different subsystems, to use these routines (because code inside *Ntdll.dll* has no dependencies). The functions that this component provides are mostly analogous to the Windows API functions and related system calls. Internally, the code also provides the functionality required to create a debug object associated with the thread. The handle to a debug

object that is created is never exposed. It is saved instead in the thread environment block (TEB) of the debugger thread that performs the attachment. (For more information on the TEB, see Chapter 4 of Part 1.) This value is saved in the *DbgSsReserved[1]* field.

When a debugger attaches to a process, it expects the process to be *broken into*—that is, an *int 3* (breakpoint) operation should have happened, generated by a thread injected into the process. If this didn't happen, the debugger would never actually be able to take control of the process and would merely see debug events flying by. Ntdll.dll is responsible for creating and injecting that thread into the target process. Note that this thread is created with a special flag, which the kernel sets on the TEB, which results in the *SkipThreadAttach* flag to be set, avoiding *DLL_THREAD_ATTACH* notifications and TLS slot usage, which could cause unwanted side effects each time a debugger would break into the process.

Finally, Ntdll.dll also provides APIs to convert the native structure for debug events into the structure that the Windows API understands. This is done by following the conversions in Table 8-33.

TABLE 8-33 Native to Win32 conversions

Native State Change	Win32 State Change	Details
<i>DbgCreateThreadStateChange</i>	CREATE_THREAD_DEBUG_EVENT	
<i>DbgCreateProcessStateChange</i>	CREATE_PROCESS_DEBUG_EVENT	lpImageName is always NULL, and fUnicode is always TRUE.
<i>DbgExitThreadStateChange</i>	EXIT_THREAD_DEBUG_EVENT	
<i>DbgExitProcessStateChange</i>	EXIT_PROCESS_DEBUG_EVENT	
<i>DbgExceptionStateChange</i> <i>DbgBreakpointStateChange</i> <i>DbgSingleStepStateChange</i>	OUTPUT_DEBUG_STRING_EVENT, RIP_EVENT, or EXCEPTION_DEBUG_EVENT	Determination is based on the Exception Code (which can be <i>DBG_PRINTEXCEPTION_C</i> / <i>DBG_PRINTEXCEPTION_WIDE_C</i> , <i>DBG_RIPEXCEPTION</i> , or something else).
<i>DbgLoadDllStateChange</i>	LOAD_DLL_DEBUG_EVENT	<i>fUnicode</i> is always TRUE
<i>DbgUnloadDllStateChange</i>	UNLOAD_DLL_DEBUG_EVENT	

EXPERIMENT: Viewing debugger objects

Although you've been using WinDbg to do kernel-mode debugging, you can also use it to debug user-mode programs. Go ahead and try starting Notepad.exe with the debugger attached using these steps:

1. Run WinDbg, and then click **File**, Open Executable.
2. Navigate to the \Windows\System32\ directory and choose Notepad.exe.
3. You're not going to do any debugging, so simply ignore whatever might come up. You can type **g** in the command window to instruct WinDbg to continue executing Notepad.

Now run Process Explorer and be sure the lower pane is enabled and configured to show open handles. (Select **View, Lower Pane View**, and then **Handles**.) You also want to look at unnamed handles, so select **View, Show Unnamed Handles And Mappings**.

Next, click the WinDbg.exe (or EngHost.exe, if you're using the WinDbg Preview) process and look at its handle table. You should see an open, unnamed handle to a debug object. (You can organize the table by Type to find this entry more readily.) You should see something like the following:

Process	PID	CPU	Private Bytes	Working Set	Description	Company Name
DbgX.Shell.exe	29540	0.29	138,476 K	191,264 K		
EngHost.exe	15296	< 0.01	23,448 K	23,844 K		
notepad.exe	28184		1,164 K	2,660 K	Notepad	Microsoft Corporation
SurfaceAppDt.exe	12192		22,640 K	4,716 K	Surface	

Type	Name	Handle	Access
DebugObject		0x0000000000000289	0x001F000F
Desktop	\Default	0x0000000000000114	0x000F01FF
Directory	\KnownDlls	0x0000000000000034	0x00000003
Directory	\Sessions\1\BaseNamedObjects	0x00000000000000E4	0x0000000F
EtwRegistration		0x0000000000000028	0x00000804

CPU Usage: 11.14% Commit Charge: 75.75% Processes: 376

You can try right-clicking the handle and closing it. Notepad should disappear, and the following message should appear in WinDbg:

```
ERROR: WaitForEvent failed, NTSTATUS 0xC0000354
This usually indicates that the debuggee has been
killed out from underneath the debugger.
You can use .tlist to see if the debuggee still exists.
```

In fact, if you look at the description for the *NTSTATUS* code given, you will find the text: "An attempt to do an operation on a debug port failed because the port is in the process of being deleted," which is exactly what you've done by closing the handle.

As you can see, the native *DbgUi* interface doesn't do much work to support the framework except for this abstraction. The most complicated task it does is the conversion between native and Win32 debugger structures. This involves several additional changes to the structures.

Windows subsystem support

The final component responsible for allowing debuggers such as Microsoft Visual Studio or WinDbg to debug user-mode applications is in *KernelBase.dll*. It provides the documented Windows APIs. Apart from this trivial conversion of one function name to another, there is one important management job that this side of the debugging infrastructure is responsible for: managing the duplicated file and thread handles.

Recall that each time a *load DLL* event is sent, a handle to the image file is duplicated by the kernel and handed off in the event structure, as is the case with the handle to the process executable during the *create process* event. During each *wait* call, *KernelBase.dll* checks whether this is an event that

results in a new duplicated process and/or thread handles from the kernel (the two *create* events). If so, it allocates a structure in which it stores the process ID, thread ID, and the thread and/or process handle associated with the event. This structure is linked into the first *DbgSsReserved* array index in the TEB, where we mentioned the debug object handle is stored. Likewise, KernelBase.dll also checks for *exit* events. When it detects such an event, it “marks” the handles in the data structure.

Once the debugger is finished using the handles and performs the *continue* call, KernelBase.dll parses these structures, looks for any handles whose threads have exited, and closes the handles for the debugger. Otherwise, those threads and processes would never exit because there would always be open handles to them if the debugger were running.

Packaged applications

Starting with Windows 8, there was a need for some APIs that run on different kind of devices, from a mobile phone, up to an Xbox and to a fully-fledged personal computer. Windows was indeed starting to be designed even for new device types, which use different platforms and CPU architectures (ARM is a good example). A new platform-agnostic application architecture, Windows Runtime (also known as “WinRT”) was first introduced in Windows 8. WinRT supported development in C++, JavaScript, and managed languages (C#, VB.Net, and so on), was based on COM, and supported natively both x86, AMD64, and ARM processors. Universal Windows Platform (UWP) is the evolution of WinRT. It has been designed to overcome some limitations of WinRT and it is built on the top of it. UWP applications no longer need to indicate which OS version has been developed for in their manifest, but instead they target one or more device families.

UWP provides Universal Device Family APIs, which are guaranteed to be present in all device families, and Extension APIs, which are device specific. A developer can target one device type, adding the extension SDK in its manifest; furthermore, she can conditionally test the presence of an API at runtime and adapt the app’s behavior accordingly. In this way, a UWP app running on a smartphone may start behaving the way it would if it were running on a PC when the phone is connected to a desktop computer or a suitable docking station.

UWP provides multiple services to its apps:

- Adaptive controls and input—the graphical elements respond to the size and DPI of the screen by adjusting their layout and scale. Furthermore, the input handling is abstracted to the underlying app. This means that a UWP app works well on different screens and with different kinds of input devices, like touch, a pen, a mouse, keyboard, or an Xbox controller
- One centralized store for every UWP app, which provides a seamless install, uninstall, and upgrade experience
- A unified design system, called Fluent (integrated in Visual Studio)
- A sandbox environment, which is called AppContainer

AppContainers were originally designed for WinRT and are still used for UWP applications. We already covered the security aspects of AppContainers in Chapter 7 of Part 1.

To properly execute and manage UWP applications, a new application model has been built in Windows, which is internally called AppModel and stands for “Modern Application Model.” The Modern Application Model has evolved and has been changed multiple times during each release of the OS. In this book, we analyze the Windows 10 Modern Application Model. Multiple components are part of the new model and cooperate to correctly manage the states of the packaged application and its background activities in an energy-efficient manner.

- **Host Activity Manager (HAM)** The Host activity manager is a new component, introduced in Windows 10, which replaces and integrates many of the old components that control the life (and the states) of a UWP application (Process Lifetime Manager, Foreground Manager, Resource Policy, and Resource Manager). The Host Activity Manager lives in the Background Task Infrastructure service (BrokerInfrastructure), not to be confused with the Background Broker Infrastructure component, and works deeply tied to the Process State Manager. It is implemented in two different libraries, which represent the client (Rmclient.dll) and server (PsmServiceExtHost.dll) interface.
- **Process State Manager (PSM)** PSM has been partly replaced by HAM and is considered part of the latter (actually PSM became a HAM client). It maintains and stores the state of each host of the packaged application. It is implemented in the same service of the HAM (BrokerInfrastructure), but in a different DLL: Pmsrv.dll.
- **Application Activation Manager (AAM)** AAM is the component responsible in the different kinds and types of activation of a packaged application. It is implemented in the ActivationManager.dll library, which lives in the User Manager service. Application Activation Manager is a HAM client.
- **View Manager (VM)** VM detects and manages UWP user interface events and activities and talks with HAM to keep the UI application in the foreground and in a nonsuspended state. Furthermore, VM helps HAM in detecting when a UWP application goes into background state. View Manager is implemented in the CoreUiComponents.dll .Net managed library, which depends on the Modern Execution Manager client interface (ExecModelClient.dll) to properly register with HAM. Both libraries live in the User Manager service, which runs in a Sihost process (the service needs to properly manage UI events)
- **Background Broker Infrastructure (BI)** BI manages the applications background tasks, their execution policies, and events. The core server is implemented mainly in the bisrv.dll library, manages the events that the brokers generate, and evaluates the policies used to decide whether to run a background task. The Background Broker Infrastructure lives in the BrokerInfrastructure service and, at the time of this writing, is not used for Centennial applications.

There are some other minor components that compose the new application model that we have not mentioned here and are beyond the scope of this book.

With the goal of being able to run even standard Win32 applications on secure devices like Windows 10 S, and to enable the conversion of old application to the new model, Microsoft has designed the Desktop Bridge (internally called Centennial). The bridge is available to developers through Visual Studio or the Desktop App Converter. Running a Win32 application in an AppContainer, even if possible, is not recommended, simply because the standard Win32 applications are designed to access a wider system API surface, which is much reduced in AppContainers.

UWP applications

We already covered an introduction of UWP applications and described the security environment in which they run in Chapter 7 of Part 1. To better understand the concepts expressed in this chapter, it is useful to define some basic properties of the modern UWP applications. Windows 8 introduced significant new properties for processes:

- Package identity
- Application identity
- AppContainer
- Modern UI

We have already extensively analyzed the AppContainer (see Chapter 7 in Part 1). When the user downloads a modern UWP application, the application usually came encapsulated in an AppX package. A package can contain different applications that are published by the same author and are linked together. A package identity is a logical construct that uniquely defines a package. It is composed of five parts: name, version, architecture, resource id, and publisher. The package identity can be represented in two ways: by using a Package Full Name (formerly known as Package Moniker), which is a string composed of all the single parts of the package identity, concatenated by an underscore character; or by using a Package Family name, which is another string containing the package name and publisher. The publisher is represented in both cases by using a Base32-encoded string of the full publisher name. In the UWP world, the terms “Package ID” and “Package full name” are equivalent. For example, the Adobe Photoshop package is distributed with the following full name:

`AdobeSystemsIncorporated.AdobePhotoshopExpress_2.6.235.0_neutral_split.scale-125_ynb6jyzte8ga`, where

- `AdobeSystemsIncorporated.AdobePhotoshopExpress` is the name of the package.
- `2.6.235.0` is the version.
- `neutral` is the targeting architecture.
- `split_scale` is the resource id.
- `ynb6jyzte8ga` is the base32 encoding (Crockford’s variant, which excludes the letters `i`, `l`, `u`, and `o` to avoid confusion with digits) of the publisher.

Its package family name is the simpler “AdobeSystemsIncorporated.AdobePhotoshopExpress_ynb6jyzte8ga” string.

Every application that composes the package is represented by an application identity. An application identity uniquely identifies the collection of windows, processes, shortcuts, icons, and functionality that form a single user-facing program, regardless of its actual implementation (so this means that in the UWP world, a single application can be composed of different processes that are still part of the same application identity). The application identity is represented by a simple string (in the UWP world, called Package Relative Application ID, often abbreviated as PRAID). The latter is always combined with the package family name to compose the Application User Model ID (often abbreviated as AUMID). For example, the Windows modern Start menu application has the following AUMID: Microsoft.Windows.ShellExperienceHost_cw5n1h2txyewy!App, where the App part is the PRAID.

Both the package full name and the application identity are located in the WIN://SYSAPPID Security attribute of the token that describes the modern application security context. For an extensive description of the security environment in which the UWP applications run, refer to Chapter 7 in Part 1.

Centennial applications

Starting from Windows 10, the new application model became compatible with standard Win32 applications. The only procedure that the developer needs to do is to run the application installer program with a special Microsoft tool called Desktop App Converter. The Desktop App Converter launches the installer under a sandboxed server Silo (internally called Argon Container) and intercepts all the file system and registry I/O that is needed to create the application package, storing all its files in VFS (virtualized file system) private folders. Entirely describing the Desktop App Converter application is outside the scope of this book. You can find more details of Windows Containers and Silos in Chapter 3 of Part 1.

The Centennial runtime, unlike UWP applications, does not create a sandbox where Centennial processes are run, but only applies a thin virtualization layer on the top of them. As result, compared to standard Win32 programs, Centennial applications don't have lower security capabilities, nor do they run with a lower integrity-level token. A Centennial application can even be launched under an administrative account. This kind of application runs in application silos (internally called Helium Container), which, with the goal of providing State separation while maintaining compatibility, provides two forms of “jails”: Registry Redirection and Virtual File System (VFS). Figure 8-42 shows an example of a Centennial application: Kali Linux.

At package activation, the system applies registry redirection to the application and merges the main system hives with the Centennial Application registry hives. Each Centennial application can include three different registry hives when installed in the user workstation: registry.dat, user.dat, and (optionally) userclasses.dat. The registry files generated by the Desktop Convert represent “immutable” hives, which are written at installation time and should not change. At application startup, the Centennial runtime merges the immutable hives with the real system registry hives (actually, the Centennial runtime executes a “detokenizing” procedure because each value stored in the hive contains relative values).

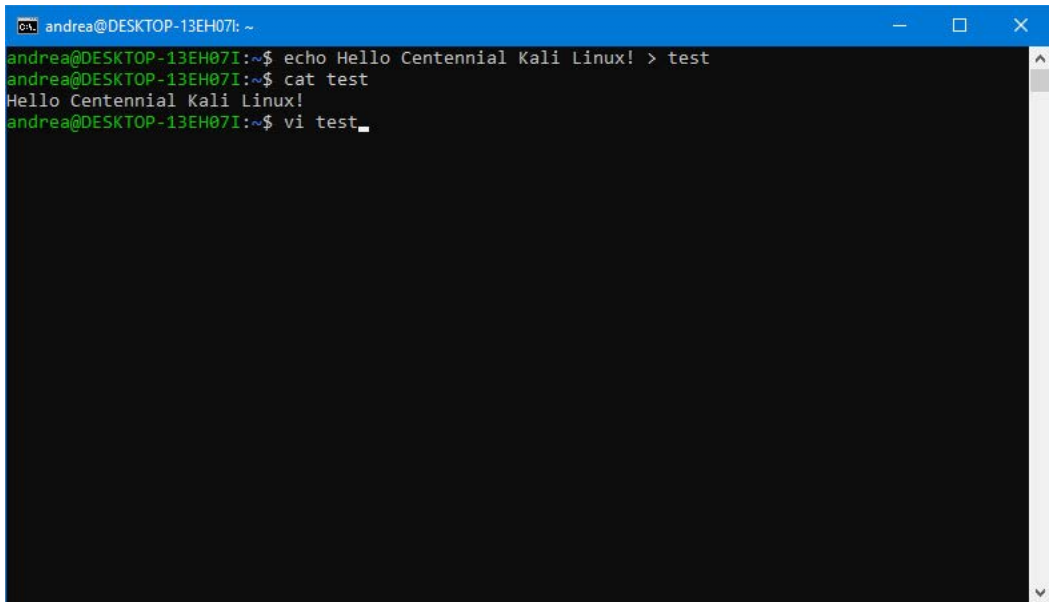

FIGURE 8-42 Kali Linux distributed on the Windows Store is a typical example of Centennial application.

The registry merging and virtualization services are provided by the Virtual Registry Namespace Filter driver (WscVReg), which is integrated in the NT kernel (Configuration Manager). At package activation time, the user mode ApplInfo service communicates with the VRegDriver device with the goal of merging and redirecting the registry activity of the Centennial applications. In this model, if the app tries to read a registry value that is present in the virtualized hives, the I/O is actually redirected to the package hives. A write operation to this kind of value is not permitted. If the value does not already exist in the virtualized hive, it is created in the real hive without any kind of redirection at all. A different kind of redirection is instead applied to the entire HKEY_CURRENT_USER root key. In this key, each new subkey or value is stored *only* in the package hive that is stored in the following path: C:\ProgramData\Packages\

TABLE 8-34 Registry virtualization applied to Centennial applications

Operation	Result
Read or enumeration of HKEY_LOCAL_MACHINE\Software	The operation returns a dynamic merge of the package hives with the local system counterpart. Registry keys and values that exist in the package hives <i>always</i> have precedence with respect to keys and values that already exist in the local system.
All writes to HKEY_CURRENT_USER	Redirected to the Centennial package virtualized hive.
All writes inside the package	Writes to HKEY_LOCAL_MACHINE\Software are not allowed if a registry value exists in one of the package hives.
All writes outside the package	Writes to HKEY_LOCAL_MACHINE\Software are allowed as long as the value does <i>not</i> already exist in one of the package hives.

When the Centennial runtime sets up the Silo application container, it walks all the file and directories located into the VFS folder of the package. This procedure is part of the Centennial Virtual File System configuration that the package activation provides. The Centennial runtime includes a list of mapping for each folder located in the VFS directory, as shown in Table 8-35.

TABLE 8-35 List of system folders that are virtualized for Centennial apps

Folder Name	Redirection Target	Architecture
SystemX86	C:\Windows\SysWOW64	32-bit/64-bit
System	C:\Windows\System32	32-bit/64-bit
SystemX64	C:\Windows\System32	64-bit only
ProgramFilesX86	C:\Program Files (x86)	32-bit/64-bit
ProgramFilesX64	C:\Program Files	64-bit only
ProgramFilesCommonX86	C:\Program Files (x86)\Common Files	32-bit/64-bit
ProgramFilesCommonX64	C:\Program Files\Common Files	64-bit only
Windows	C:\Windows	Neutral
CommonAppData	C:\ProgramData	Neutral

The File System Virtualization is provided by three different drivers, which are heavily used for Argon containers:

- **Windows Bind minifilter driver (BindFlt)** Manages the redirection of the Centennial application's files. This means that if the Centennial app wants to read or write to one of its existing virtualized files, the I/O is redirected to the file's original position. When the application creates instead a file on one of the virtualized folders (for example, in C:\Windows), and the file does not already exist, the operation is allowed (assuming that the user has the needed permissions) and the redirection is not applied.
- **Windows Container Isolation minifilter driver (Wcifs)** Responsible for merging the content of different virtualized folders (called layers) and creating a unique view. Centennial applications use this driver to merge the content of the local user's application data folder (usually C:\Users\\AppData) with the app's application cache folder, located in C:\User\\Appdata\Local\Packages\\LocalCache. The driver is even able to manage the merge of multiple packages, meaning that each package can operate on its own private view of the merged folders. To support this feature, the driver stores a Layer ID of each package in the Reparse point of the target folder. In this way, it can construct a layer map in memory and is able to operate on different private areas (internally called Scratch areas). This advanced feature, at the time of this writing, is configured only for related set, a feature described later in the chapter.
- **Windows Container Name Virtualization minifilter driver (Wcnfs)** While Wcifs driver merges multiple folders, Wcnfs is used by Centennial to set up the name redirection of the local user application data folder. Unlike from the previous case, when the app creates a new file or folder in the virtualized application data folder, the file is stored in the application cache folder, and not in the real one, regardless of whether the file already exists.

One important concept to keep in mind is that the BindFlt filter operates on single files, whereas Wcnfs and Wcifs drivers operate on folders. Centennial uses minifilters' communication ports to correctly set up the virtualized file system infrastructure. The setup process is completed using a message-based communication system (where the Centennial runtime sends a message to the minifilter and waits for its response). Table 8-36 shows a summary of the file system virtualization applied to Centennial applications.

TABLE 8-36 File system virtualization applied to Centennial applications

Operation	Result
Read or enumeration of a well-known Windows folder	The operation returns a dynamic merge of the corresponding VFS folder with the local system counterpart. File that exists in the VFS folder <i>always</i> had precedence with respect to files that already exist in the local system one.
Writes on the application data folder	All the writes on the application data folder are redirected to the local Centennial application cache.
All writes inside the package folder	Forbidden, read-only.
All writes outside the package folder	Allowed if the user has permission.

The Host Activity Manager

Windows 10 has unified various components that were interacting with the state of a packaged application in a noncoordinated way. As a result, a brand-new component, called Host Activity Manager (HAM) became the central component and the only one that manages the state of a packaged application and exposes a unified API set to all its clients.

Unlike its predecessors, the Host Activity Manager exposes activity-based interfaces to its clients. A host is the object that represents the smallest unit of isolation recognized by the Application model. Resources, suspend/resume and freeze states, and priorities are managed as a single unit, which usually corresponds to a Windows Job object representing the packaged application. The job object may contain only a single process for simple applications, but it could contain even different processes for applications that have multiple background tasks (such as multimedia players, for example).

In the new Modern Application Model, there are three job types:

- **Mixed** A mix of foreground and background activities but typically associated with the foreground part of the application. Applications that include background tasks (like music playing or printing) use this kind of job type.
- **Pure** A host that is used for purely background work.
- **System** A host that executes Windows code on behalf of the application (for example, background downloads).

An activity always belongs to a host and represents the generic interface for client-specific concepts such as windows, background tasks, task completions, and so on. A host is considered "Active" if its job is unfrozen and it has at least one running activity. The HAM clients are components that interact and control the lifetime of activities. Multiple components are HAM clients: View Manager, Broker Infrastructure, various Shell components (like the Shell Experience Host), AudioSrv, Task completions, and even the Windows Service Control Manager.

The Modern application's lifecycle consists of four states: running, suspending, suspend-complete, and suspended (states and their interactions are shown in Figure 8-43.)

- **Running** The state where an application is executing part of its code, other than when it's suspending. An application could be in "running" state not only when it is in a foreground state but even when it is running background tasks, playing music, printing, or any number of other background scenarios.
- **Suspending** This state represents a time-limited transition state that happens where HAM asks the application to suspend. HAM can do this for different reasons, like when the application loses the foreground focus, when the system has limited resources or is entering a battery-safe mode, or simply because an app is waiting for some UI event. When this happens, an app has a limited amount of time to go to the suspended state (usually 5 seconds maximum); otherwise, it will be terminated.
- **SuspendComplete** This state represents an application that has finished suspending and notifies the system that it is done. Therefore, its suspend procedure is considered completed.
- **Suspended** Once an app completes suspension and notifies the system, the system freezes the application's job object using the *NtSetInformationJobObject* API call (through the *JobObjectFreezeInformation* information class) and, as a result, none of the app code can run.

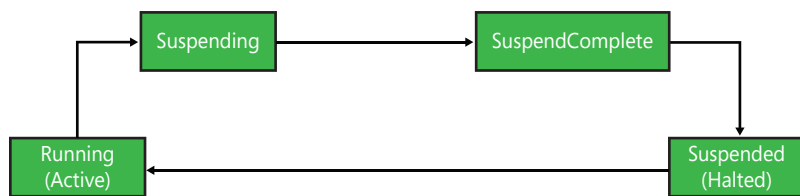

FIGURE 8-43 Scheme of the lifecycle of a packaged application.

With the goal of preserving system efficiency and saving system resources, the Host Activity Manager by default will always require an application to suspend. HAM clients need to require keeping an application alive to HAM. For foreground applications, the component responsible in keeping the app alive is the View Manager. The same applies for background tasks: Broker Infrastructure is the component responsible for determining which process hosting the background activity should remain alive (and will request to HAM to keep the application alive).

Packaged applications do not have a Terminated state. This means that an application does not have a real notion of an Exit or Terminate state and should not try to terminate itself. The actual model for terminating a Packaged application is that first it gets suspended, and then HAM, if required, calls *NtTerminateJobObject* API on the application's job object. HAM automatically manages the app lifetime and destroys the process only as needed. HAM does not decide itself to terminate the application; instead, its clients are required to do so (the View Manager or the Application Activation Manager are good examples). A packaged application can't distinguish whether it has been suspended or terminated. This allows Windows to automatically restore the previous state of the application even if it has been terminated or if the system has been rebooted. As a result, the packaged application model is completely different from the standard Win32 application model.

To properly suspend and resume a Packaged application, the Host Activity manager uses the new *PsFreezeProcess* and *PsThawProcess* kernel APIs. The process Freeze and Thaw operations are similar to suspend and resume, with the following two major differences:

- A new thread that is injected or created in a context of a deep-frozen process will not run even in case the *CREATE_SUSPENDED* flag is not used at creation time or in case the *NtResumeProcess* API is called to start the thread.
- A new Freeze counter is implemented in the *EPROCESS* data structures. This means that a process could be frozen multiple times. To allow a process to be thawed, the total number of thaw requests must be equal to the number of freeze requests. Only in this case are all the nonsuspended threads allowed to run.

The State Repository

The Modern Application Model introduces a new way for storing packaged applications' settings, package dependencies, and general application data. The State Repository is the new central store that contains all this kind of data and has an important central rule in the management of all modern applications: Every time an application is downloaded from the store, installed, activated, or removed, new data is read or written to the repository. The classical usage example of the State Repository is represented by the user clicking on a tile in the Start menu. The Start menu resolves the full path of the application's activation file (which could be an EXE or a DLL, as already seen in Chapter 7 of Part 1), reading from the repository. (This is actually simplified, because the *ShellExecutionHost* process enumerates all the modern applications at initialization time.)

The State Repository is implemented mainly in two libraries: *Windows.StateRepository.dll* and *Windows.StateRepositoryCore.dll*. Although the State Repository Service runs the server part of the repository, UWP applications talk with the repository using the *Windows.StateRepositoryClient.dll* library. (All the repository APIs are full trust, so WinRT clients need a Proxy to correctly communicate with the server. This is the rule of another DLL, named *Windows.StateRepositoryPs.dll*.) The root location of the State Repository is stored in the *HKLM\SOFTWARE\Microsoft\Windows\CurrentVersion\Appx\PackageRepositoryRoot* registry value, which usually points to the *C:\ProgramData\Microsoft\Windows\AppRepository* path.

The State Repository is implemented across multiple databases, called partitions. Tables in the database are called entities. Partitions have different access and lifetime constraints:

- **Machine** This database includes package definitions, an application's data and identities, and primary and secondary tiles (used in the Start menu), and it is the master registry that defines who can access which package. This data is read extensively by different components (like the *TileDataRepository* library, which is used by Explorer and the Start menu to manage the different tiles), but it's written primarily by the AppX deployment (rarely by some other minor components). The Machine partition is usually stored in a file called *StateRepository-Machine.srd* located into the state repository root folder.
- **Deployment** Stores machine-wide data mostly used only by the deployment service (*AppxSvc*) when a new package is registered or removed from the system. It includes the

applications file list and a copy of each modern application's manifest file. The Deployment partition is usually stored in a file called `StateRepository-Deployment.srd`.

All partitions are stored as SQLite databases. Windows compiles its own version of SQLite into the `StateRepository.Core.dll` library. This library exposes the State Repository Data Access Layer (also known as DAL) APIs that are mainly wrappers to the internal database engine and are called by the State Repository service.

Sometimes various components need to know when some data in the State Repository is written or modified. In Windows 10 Anniversary update, the State Repository has been updated to support changes and events tracking. It can manage different scenarios:

- A component wants to subscribe for data changes for a certain entity. The component receives a callback when the data is changed and implemented using a SQL transaction. Multiple SQL transactions are part of a Deployment operation. At the end of each database transaction, the State Repository determines if a Deployment operation is completed, and, if so, calls each registered listener.
- A process is started or wakes from Suspend and needs to discover what data has changed since it was last notified or looked at. State Repository could satisfy this request using the *Changeld* field, which, in the tables that supports this feature, represents a unique temporal identifier of a record.
- A process retrieves data from the State Repository and needs to know if the data has changed since it was last examined. Data changes are always recorded in compatible entities via a new table called *Changelog*. The latter always records the time, the change ID of the event that created the data, and, if applicable, the change ID of the event that deleted the data.

The modern Start menu uses the changes and events tracking feature of the State Repository to work properly. Every time the `ShellExperienceHost` process starts, it requests the State Repository to notify its controller (`NotificationController.dll`) every time a tile is modified, created, or removed. When the user installs or removes a modern application through the Store, the application deployment server executes a DB transaction for inserting or removing the tile. The State Repository, at the end of the transaction, signals an event that wakes up the controller. In this way, the Start menu can modify its appearance almost in real time.



Note In a similar way, the modern Start menu is automatically able to add or remove an entry for every new standard Win32 application installed. The application setup program usually creates one or more shortcuts in one of the classic Start menu folder locations (systemwide path: `C:\ProgramData\Microsoft\Windows\Start Menu`, or per-user path: `C:\Users\<UserName>\AppData\Roaming\Microsoft\Windows\Start Menu`). The modern Start menu uses the services provided by the `AppResolver` library to register file system notifications on all the Start menu folders (through the `ReadDirectoryChangesW` Win32 API). In this way, whenever a new shortcut is created in the monitored folders, the library can get a callback and signal the Start menu to redraw itself.

EXPERIMENT: Witnessing the state repository

You can open each partition of the state repository fairly easily using your preferred SQLite browser application. For this experiment, you need to download and install an SQLite browser, like the open-source DB Browser for SQLite, which you can download from <http://sqlitebrowser.org/>. The State Repository path is not accessible by standard users. Furthermore, each partition's file could be in use in the exact moment that you will access it. Thus, you need to copy the database file in another folder before trying to open it with the SQLite browser. Open an administrative command prompt (by typing **cmd** in the Cortana search box and selecting **Run As Administrator** after right-clicking the Command Prompt label) and insert the following commands:

```
C:\WINDOWS\system32>cd "C:\ProgramData\Microsoft\Windows\AppRepository"  
C:\ProgramData\Microsoft\Windows\AppRepository>copy StateRepository-Machine.srd  
"%USERPROFILE%\Documents"
```

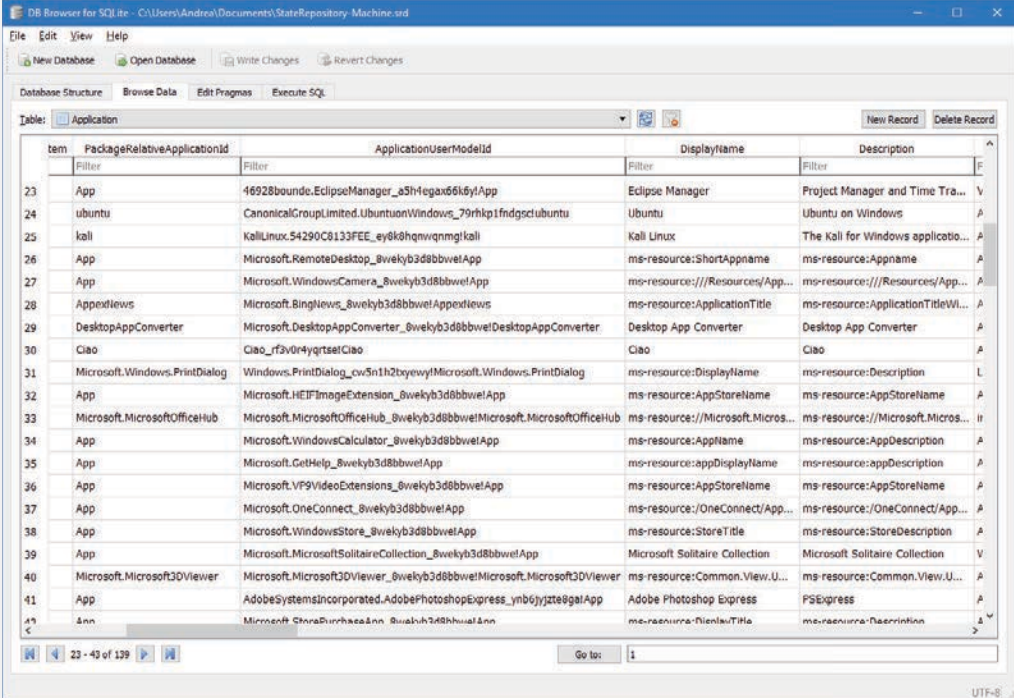

The screenshot shows the DB Browser for SQLite application window. The main area displays a table with the following columns: Item, PackageRelativeApplicationId, ApplicationUserModelId, DisplayName, and Description. The table contains 43 rows of application data, including entries for Eclipse Manager, Ubuntu, Kali Linux, and various Microsoft applications.

Item	PackageRelativeApplicationId	ApplicationUserModelId	DisplayName	Description
23	App	46928b0unde.EclipseManager_a5H4ega66k6ylApp	Eclipse Manager	Project Manager and Time Tra...
24	ubuntu	CanonicalGroupLimited.UbuntuonWindows_79rhk1fndgscIubuntu	Ubuntu	Ubuntu on Windows
25	kali	KaliLinux.54290C8133FEE_ey8k9hqwqnmqIkali	Kali Linux	The Kali for Windows applico...
26	App	Microsoft.RemoteDesktop_8vekyb3d8bbweIApp	ms-resource:ShortAppName	ms-resource:AppName
27	App	Microsoft.Windows.Camera_8vekyb3d8bbweIApp	ms-resource:///Resource/App...	ms-resource:///Resource/App...
28	AppxViews	Microsoft.BingNews_8vekyb3d8bbweIAppxViews	ms-resource:ApplicationTitle	ms-resource:ApplicationTitleW...
29	DesktopAppConverter	Microsoft.DesktopAppConverter_8vekyb3d8bbweIDesktopAppConverter	Desktop App Converter	Desktop App Converter
30	Ciao	Ciao_rf3v0r4yqrtsetCiao	Ciao	Ciao
31	Microsoft.Windows.PrintDialog	Windows.PrintDialog_cv5n1h2byewyIMicrosoft.Windows.PrintDialog	ms-resource:DisplayName	ms-resource:Description
32	App	Microsoft.HEIFImageExtension_8vekyb3d8bbweIApp	ms-resource:AppStoreName	ms-resource:AppStoreName
33	Microsoft.MicrosoftOfficeHub	Microsoft.MicrosoftOfficeHub_8vekyb3d8bbweIMicrosoft.MicrosoftOfficeHub	ms-resource://Microsoft.Micros...	ms-resource://Microsoft.Micros...
34	App	Microsoft.Windows.Calculator_8vekyb3d8bbweIApp	ms-resource:AppName	ms-resource:AppDescription
35	App	Microsoft.GetHelp_8vekyb3d8bbweIApp	ms-resource:appDisplayName	ms-resource:appDescription
36	App	Microsoft.VP9VideoExtensions_8vekyb3d8bbweIApp	ms-resource:AppStoreName	ms-resource:AppStoreName
37	App	Microsoft.OneConnect_8vekyb3d8bbweIApp	ms-resource://OneConnect/App...	ms-resource://OneConnect/App...
38	App	Microsoft.WindowsStore_8vekyb3d8bbweIApp	ms-resource:StoreTitle	ms-resource:StoreDescription
39	App	Microsoft.MicrosoftSolitaireCollection_8vekyb3d8bbweIApp	Microsoft Solitaire Collection	Microsoft Solitaire Collection
40	Microsoft.Microsoft3DViewer	Microsoft.Microsoft3DViewer_8vekyb3d8bbweIMicrosoft.Microsoft3DViewer	ms-resource:Common.View.U...	ms-resource:Common.View.U...
41	App	AdobeSystemsIncorporated.AdobePhotoshopExpress_ynb6jy3te9galApp	Adobe Photoshop Express	PSExpress
42	App	Microsoft.StorePurchaseApp_8vekyb3d8bbweIApp	ms-resource:DisplayName	ms-resource:Description

In this way, you have copied the State Repository machine partition into your Documents folder. The next stage is to open it. Start DB Browser for SQLite using the link created in the Start menu or the Cortana search box and click the **Open Database** button. Navigate to the Documents folder, select **All Files (*)** in the **File Type** combo box (the state repository database doesn't use a standard SQLite file extension), and open the copied StateRepository-machine.

srd file. The main view of DB Browser for SQLite is the database structure. For this experiment you need to choose the **Browse Data** sheet and navigate through the tables like Package, Application, PackageLocation, and PrimaryTile.

The Application Activation Manager and many other components of the Modern Application Model use standard SQL queries to extract the needed data from the State Repository. For example, to extract the package location and the executable name of a modern application, a SQL query like the following one could be used:

```
SELECT p.DisplayName, p.PackageFullName, pl.InstalledLocation, a.Executable, pm.Name
FROM Package AS p
INNER JOIN PackageLocation AS pl ON p._PackageID=pl.Package
INNER JOIN PackageFamily AS pm ON p.PackageFamily=pm._PackageFamilyID
INNER JOIN Application AS a ON a.Package=p._PackageID
WHERE pm.PackageFamilyName="<Package Family Name>"
```

The DAL (Data Access Layer) uses similar queries to provide services to its clients.

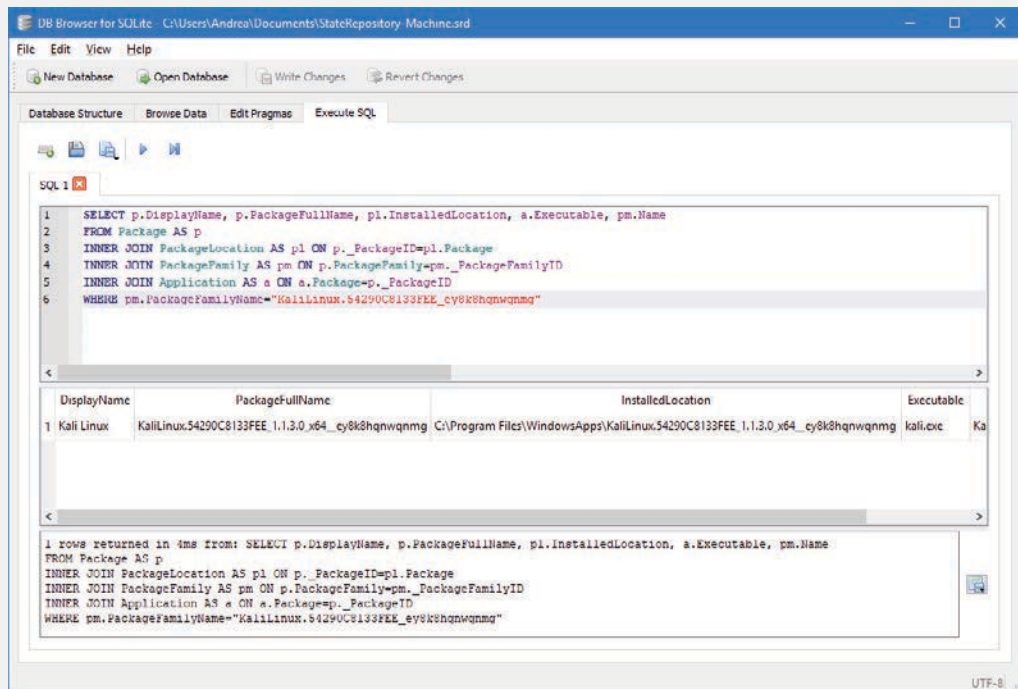

You can annotate the total number of records in the table and then install a new application from the store. If, after the deployment process is completed, you again copy the database file, you will find that number of the records change. This happens in multiple tables. Especially if the new app installs a new tile, even the PrimaryTile table adds a record for the new tile shown in the Start menu.

The Dependency Mini Repository

Opening an SQLite database and extracting the needed information through an SQL query could be an expensive operation. Furthermore, the current architecture requires some interprocess communication done through RPC. Those two constraints sometimes are too restrictive to be satisfied. A classic example is represented by a user launching a new application (maybe an Execution Alias) through the command-line console. Checking the State Repository every time the system spawns a process introduces a big performance issue. To fix these problems, the Application Model has introduced another smaller store that contains Modern applications' information: the Dependency Mini Repository (DMR).

Unlike from the State Repository, the Dependency Mini Repository does not make use of any database but stores the data in a Microsoft-proprietary binary format that can be accessed by any file system in any security context (even a kernel-mode driver could possibly parse the DMR data). The System Metadata directory, which is represented by a folder named Packages in the State Repository root path, contains a list of subfolders, one for every installed package. The Dependency Mini Repository is represented by a .pkgdep file, named as the user's SID. The DMR file is created by the Deployment service when a package is registered for a user (for further details, see the "Package registration" section later in this chapter).

The Dependency Mini Repository is heavily used when the system creates a process that belongs to a packaged application (in the AppX Pre-CreateProcess extension). Thus, it's entirely implemented in the Win32 kernelbase.dll (with some stub functions in kernel.appcore.dll). When a DMR file is opened at process creation time, it is read, parsed, and memory-mapped into the parent process. After the child process is created, the loader code maps it even in the child process. The DMR file contains various information, including

- Package information, like the ID, full name, full path, and publisher
- Application information: application user model ID and relative ID, description, display name, and graphical logos
- Security context: AppContainer SID and capabilities
- Target platform and the package dependencies graph (used in case a package depends on one or more others)

The DMR file is designed to contain even additional data in future Windows versions, if required. Using the Dependency Mini Repository file, the process creation is fast enough and does not require a query into the State Repository. Noteworthy is that the DMR file is closed after the process creation. So, it is possible to rewrite the .pkgdep file, adding an optional package even when the Modern application is executing. In this way, the user can add a feature to its modern application without restarting it. Some small parts of the package mini repository (mostly only the package full name and path) are replicated into different registry keys as cache for a faster access. The cache is often used for common operations (like understanding if a package exists).

Background tasks and the Broker Infrastructure

UWP applications usually need a way to run part of their code in the background. This code doesn't need to interact with the main foreground process. UWP supports background tasks, which provide functionality to the application even when the main process is suspended or not running. There are multiple reasons why an application may use background tasks: real-time communications, mails, IM, multimedia music, video player, and so on. A background task could be associated by triggers and conditions. A trigger is a global system asynchronous event that, when it happens, signals the starting of a background task. The background task at this point may or may be not started based on its applied conditions. For example, a background task used in an IM application could start only when the user logs on (a system event trigger) and only if the Internet connection is available (a condition).

In Windows 10, there are two types of background tasks:

- **In-process background task** The application code and its background task run in the same process. From a developer's point of view, this kind of background task is easier to implement, but it has the big drawback that if a bug hits its code, the entire application crashes. The in-process background task doesn't support all triggers available for the out-of-process background tasks.
- **Out-of-process background task** The application code and its background task run in different processes (the process could run in a different job object, too). This type of background task is more resilient, runs in the backgroundtaskhost.exe host process, and can use all the triggers and the conditions. If a bug hits the background task, this will never kill the entire application. The main drawback is originated from the performance of all the RPC code that needs to be executed for the interprocess communication between different processes.

To provide the best user experience for the user, all background tasks have an execution time limit of 30 seconds total. After 25 seconds, the Background Broker Infrastructure service calls the task's Cancellation handler (in WinRT, this is called OnCanceled event). When this event happens, the background task still has 5 seconds to completely clean up and exit. Otherwise, the process that contains the Background Task code (which could be BackgroundTaskHost.exe in case of out-of-process tasks; otherwise, it's the application process) is terminated. Developers of personal or business UWP applications can remove this limit, but such an application could not be published in the official Microsoft Store.

The Background Broker Infrastructure (BI) is the central component that manages all the Background tasks. The component is implemented mainly in bisrv.dll (the server side), which lives in the Broker Infrastructure service. Two types of clients can use the services provided by the Background Broker Infrastructure: Standard Win32 applications and services can import the bi.dll Background Broker Infrastructure client library; WinRT applications always link to biwinrt.dll, the library that provides WinRT APIs to modern applications. The Background Broker Infrastructure could not exist without the brokers. The brokers are the components that generate the events that are consumed by the Background Broker Server. There are multiple kinds of brokers. The most important are the following:

- **System Event Broker** Provides triggers for system events like network connections' state changes, user logon and logoff, system battery state changes, and so on
- **Time Broker** Provides repetitive or one-shot timer support

- **Network Connection Broker** Provides a way for the UWP applications to get an event when a connection is established on certain ports
- **Device Services Broker** Provides device arrivals triggers (when a user connects or disconnects a device). Works by listening Pnp events originated from the kernel
- **Mobile Broad Band Experience Broker** Provides all the critical triggers for phones and SIMs

The server part of a broker is implemented as a windows service. The implementation is different for every broker. Most work by subscribing to WNF states (see the “Windows Notification Facility” section earlier in this chapter for more details) that are published by the Windows kernel; others are built on top of standard Win32 APIs (like the Time Broker). Covering the implementation details of all the brokers is outside the scope of this book. A broker can simply forward events that are generated somewhere else (like in the Windows kernel) or can generate new events based on some other conditions and states. Brokers forward events that they managed through WNF: each broker creates a WNF state name that the background infrastructure subscribes to. In this way, when the broker publishes new state data, the Broker Infrastructure, which is listening, wakes up and forwards the event to its clients.

Each broker includes even the client infrastructure: a WinRT and a Win32 library. The Background Broker Infrastructure and its brokers expose three kinds of APIs to its clients:

- **Non-trust APIs** Usually used by WinRT components that run under AppContainer or in a sandbox environment. Supplementary security checks are made. The callers of this kind of API can't specify a different package name or operate on behalf of another user (that is, *BiRtCreateEventForApp*).
- **Partial-trust APIs** Used by Win32 components that live in a Medium-IL environment. Callers of this kind of API can specify a Modern application's package full name but can't operate on behalf of another user (that is, *BiPtCreateEventForApp*).
- **Full-trust API** Used only by high-privileged system or administrative Win32 services. Callers of these APIs can operate on behalf of different users and on different packages (that is, *BiCreateEventForPackageName*).

Clients of the brokers can decide whether to subscribe directly to an event provided by the specific broker or subscribe to the Background Broker Infrastructure. WinRT always uses the latter method. Figure 8-44 shows an example of initialization of a Time trigger for a Modern Application Background task.

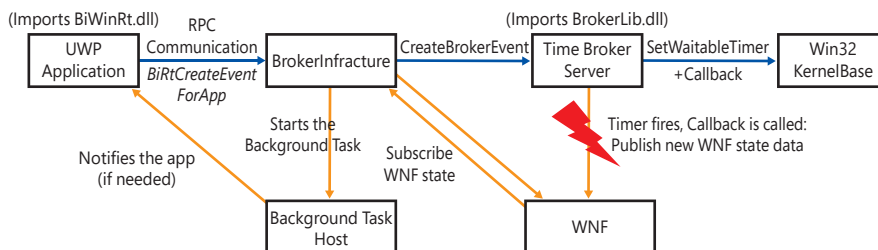

FIGURE 8-44 Architecture of the Time Broker.

Another important service that the Background Broker Infrastructure provides to the Brokers and to its clients is the storage capability for background tasks. This means that when the user shuts down and then restarts the system, all the registered background tasks are restored and rescheduled as before the system was restarted. To achieve this properly, when the system boots and the Service Control Manager (for more information about the Service Control Manager, refer to Chapter 10) starts the Broker Infrastructure service, the latter, as a part of its initialization, allocates a root storage GUID, and, using *NtLoadKeyEx* native API, loads a private copy of the Background Broker registry hive. The service tells NT kernel to load a private copy of the hive using a special flag (*REG_APP_HIVE*). The BI hive resides in the `C:\Windows\System32\Config\BBI` file. The root key of the hive is mounted as `\Registry\A\ and is accessible only to the Broker Infrastructure service's process (svchost.exe, in this case; Broker Infrastructure runs in a shared service host). The Broker Infrastructure hive contains a list of events and work items, which are ordered and identified using GUIDs:`

- **An event represents a Background task's trigger** It is associated with a broker ID (which represents the broker that provides the event type), the package full name, and the user of the UWP application that it is associated with, and some other parameters.
- **A work item represents a scheduled Background task** It contains a name, a list of conditions, the task entry point, and the associated trigger event GUID.

The BI service enumerates each subkey and then restores all the triggers and background tasks. It cleans orphaned events (the ones that are not associated with any work items). It then finally publishes a WNF ready state name. In this way, all the brokers can wake up and finish their initialization.

The Background Broker Infrastructure is deeply used by UWP applications. Even regular Win32 applications and services can make use of BI and brokers, through their Win32 client libraries. Some notable examples are provided by the Task Scheduler service, Background Intelligent Transfer service, Windows Push Notification service, and AppReadiness.

Packaged applications setup and startup

Packaged application lifetime is different than standard Win32 applications. In the Win32 world, the setup procedure for an application can vary from just copying and pasting an executable file to executing complex installation programs. Even if launching an application is just a matter of running an executable file, the Windows loader takes care of all the work. The setup of a Modern application is instead a well-defined procedure that passes mainly through the Windows Store. In Developer mode, an administrator is even able to install a Modern application from an external `.Appx` file. The package file needs to be digitally signed, though. This package registration procedure is complex and involves multiple components.

Before digging into package registration, it's important to understand another key concept that belongs to Modern applications: package activation. Package activation is the process of launching a Modern application, which can or cannot show a GUI to the user. This process is different based on the type of Modern application and involves various system components.

Package activation

A user is not able to launch a UWP application by just executing its .exe file (excluding the case of the new AppExecution aliases, created just for this reason. We describe AppExecution aliases later in this chapter). To correctly activate a Modern application, the user needs to click a tile in the modern menu, use a special link file that Explorer is able to parse, or use some other activation points (double-click an application's document, invoke a special URL, and so on). The ShellExperienceHost process decides which activation performs based on the application type.

UWP applications

The main component that manages this kind of activation is the Activation Manager, which is implemented in ActivationManager.dll and runs in a sihost.exe service because it needs to interact with the user's desktop. The activation manager strictly cooperates with the View Manager. The modern menu calls into the Activation Manager through RPC. The latter starts the activation procedure, which is schematized in Figure 8-45:

- Gets the SID of the user that is requiring the activation, the package family ID, and PRAID of the package. In this way, it can verify that the package is actually registered in the system (using the Dependency Mini Repository and its registry cache).
- If the previous check yields that the package needs to be registered, it calls into the AppX Deployment client and starts the package registration. A package might need to be registered in case of "on-demand registration," meaning that the application is downloaded but not completely installed (this saves time, especially in enterprise environments) or in case the application needs to be updated. The Activation Manager knows if one of the two cases happens thanks to the State Repository.
- It registers the application with HAM and creates the HAM host for the new package and its initial activity.
- Activation Manager talks with the View Manager (through RPC), with the goal of initializing the GUI activation of the new session (even in case of background activations, the View Manager always needs to be informed).
- The activation continues in the DcomLaunch service because the Activation Manager at this stage uses a WinRT class to launch the low-level process creation.
- The DcomLaunch service is responsible in launching COM, DCOM, and WinRT servers in response to object activation requests and is implemented in the rpcss.dll library. DcomLaunch captures the activation request and prepares to call the *CreateProcessAsUser* Win32 API. Before doing this, it needs to set the proper process attributes (like the package full name), ensure that the user has the proper license for launching the application, duplicate the user token, set the low integrity level to the new one, and stamp it with the needed security attributes. (Note that the DcomLaunch service runs under a System account, which has TCB privilege. This kind of token manipulation requires TCB privilege. See Chapter 7 of Part 1 for further details.) At this point, DcomLaunch calls *CreateProcessAsUser*, passing the package full name through one of the process attributes. This creates a suspended process.

- The rest of the activation process continues in `KernelBase.dll`. The token produced by `DComLaunch` is still not an `AppContainer` but contains the UWP Security attributes. A Special code in the `CreateProcessInternal` function uses the registry cache of the Dependency Mini Repository to gather the following information about the packaged application: Root Folder, Package State, `AppContainer` package SID, and list of application's capabilities. It then verifies that the license has not been tampered with (a feature used extensively by games). At this point, the Dependency Mini Repository file is mapped into the parent process, and the UWP application DLL alternate load path is resolved.
- The `AppContainer` token, its object namespace, and symbolic links are created with the `BasepCreateLowBox` function, which performs the majority of the work in user mode, except for the actual `AppContainer` token creation, which is performed using the `NtCreateLowBoxToken` kernel function. We have already covered `AppContainer` tokens in Chapter 7 of Part 1.
- The kernel process object is created as usual by using `NtCreateUserProcess` kernel API.
- After the `CSRSS` subsystem has been informed, the `BasepPostSuccessAppXExtension` function maps the Dependency Mini Repository in the PEB of the child process and unmaps it from the parent process. The new process can then be finally started by resuming its main thread.

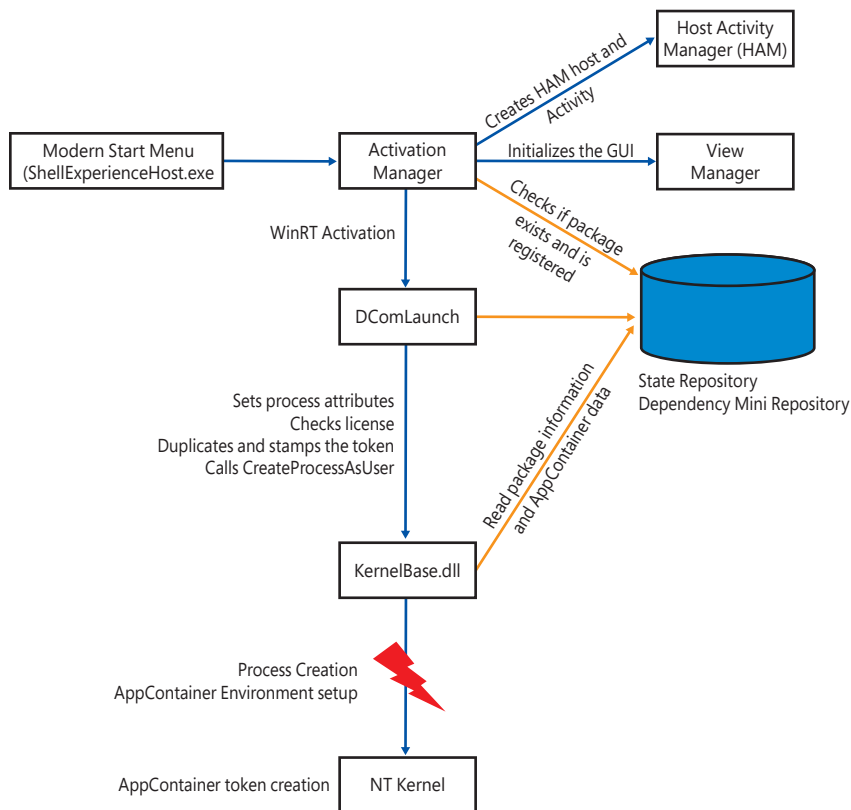

FIGURE 8-45 Scheme of the activation of a modern UWP application.

Centennial applications

The Centennial applications activation process is similar to the UWP activation but is implemented in a totally different way. The modern menu, ShellExperienceHost, always calls into Explorer.exe for this kind of activation. Multiple libraries are involved in the Centennial activation type and mapped in Explorer, like Daxexec.dll, Twinui.dll, and Windows.Storage.dll. When Explorer receives the activation request, it gets the package full name and application id, and, through RPC, grabs the main application executable path and the package properties from the State Repository. It then executes the same steps (2 through 4) as for UWP activations. The main difference is that, instead of using the DcomLaunch service, Centennial activation, at this stage, it launches the process using the *ShellExecute* API of the Shell32 library. *ShellExecute* code has been updated to recognize Centennial applications and to use a special activation procedure located in Windows.Storage.dll (through COM). The latter library uses RPC to call the *RAILaunchProcessWithIdentity* function located in the AppInfo service. AppInfo uses the State Repository to verify the license of the application, the integrity of all its files, and the calling process's token. It then stamps the token with the needed security attributes and finally creates the process in a suspended state. AppInfo passes the package full name to the *CreateProcessAsUser* API using the *PROC_THREAD_ATTRIBUTE_PACKAGE_FULL_NAME* process attribute.

Unlike the UWP activation, no AppContainer is created at all, AppInfo calls the *PostCreateProcessDesktopAppXActivation* function of DaxExec.dll, with the goal of initializing the virtualization layer of Centennial applications (registry and file system). Refer to the “Centennial application” section earlier in this chapter for further information.

EXPERIMENT: Activate Modern apps through the command line

In this experiment, you will understand better the differences between UWP and Centennial, and you will discover the motivation behind the choice to activate Centennial applications using the ShellExecute API. For this experiment, you need to install at least one Centennial application. At the time of this writing, a simple method to recognize this kind of application exists by using the Windows Store. In the store, after selecting the target application, scroll down to the “Additional Information” section. If you see “This app can: Uses all system resources,” which is usually located before the “Supported languages” part, it means that the application is Centennial type.

In this experiment, you will use Notepad++. Search and install the “(unofficial) Notepad++” application from the Windows Store. Then open the Camera application and Notepad++. Open an administrative command prompt (you can do this by typing **cmd** in the Cortana search box and selecting Run As Administrator after right-clicking the Command Prompt label). You need to find the full path of the two running packaged applications using the following commands:

```
wmic process where "name='WindowsCamera.exe'" get ExecutablePath  
wmic process where "name='notepad++.exe'" get ExecutablePath
```

Now you can create two links to the application's executables using the commands:

```
mklink "%USERPROFILE%\Desktop\notepad.exe" "<Notepad++ executable Full Path>"
mklink "%USERPROFILE%\Desktop\camera.exe" "<WindowsCamera executable full path>"
```

replacing the content between the < and > symbols with the real executable path discovered by the first two commands.

You can now close the command prompt and the two applications. You should have created two new links in your desktop. Unlike with the Notepad.exe link, if you try to launch the Camera application from your desktop, the activation fails, and Windows returns an error dialog box like the following:

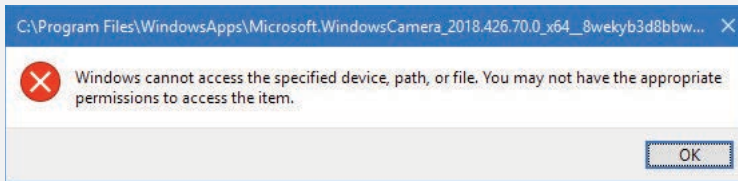

This happens because Windows Explorer uses the Shell32 library to activate executable links. In the case of UWP, the Shell32 library has no idea that the executable it will launch is a UWP application, so it calls the *CreateProcessAsUser* API without specifying any package identity. In a different way, Shell32 can identify Centennial apps; thus, in this case, the entire activation process is executed, and the application correctly launched. If you try to launch the two links using the command prompt, none of them will correctly start the application. This is explained by the fact that the command prompt doesn't make use of Shell32 at all. Instead, it invokes the *CreateProcess* API directly from its own code. This demonstrates the different activations of each type of packaged application.



Note Starting with Windows 10 Creators Update (RS2), the Modern Application Model supports the concept of Optional packages (internally called RelatedSet). Optional packages are heavily used in games, where the main game supports even DLC (or expansions), and in packages that represent suites: Microsoft Office is a good example. A user can download and install Word and implicitly the framework package that contains all the Office common code. When the user wants to install even Excel, the deployment operation could skip the download of the main Framework package because Word is an optional package of its main Office framework.

Optional packages have relationship with their main packages through their manifest files. In the manifest file, there is the declaration of the dependency to the main package (using AMUID). Deeply describing Optional packages architecture is beyond the scope of this book.

AppExecution aliases

As we have previously described, packaged applications could not be activated directly through their executable file. This represents a big limitation, especially for the new modern Console applications. With the goal of enabling the launch of Modern apps (Centennial and UWP) through the command line, starting from Windows 10 Fall Creators Update (build 1709), the Modern Application Model has introduced the concept of AppExecution aliases. With this new feature, the user can launch Edge or any other modern applications through the console command line. An AppExecution alias is basically a 0-bytes length executable file located in `C:\Users\\AppData\Local\Microsoft\WindowsApps` (as shown in Figure 8-46.). The location is added in the system executable search path list (through the `PATH` environment variable); as a result, to execute a modern application, the user could specify any executable file name located in this folder without the complete path (like in the Run dialog box or in the console command line).

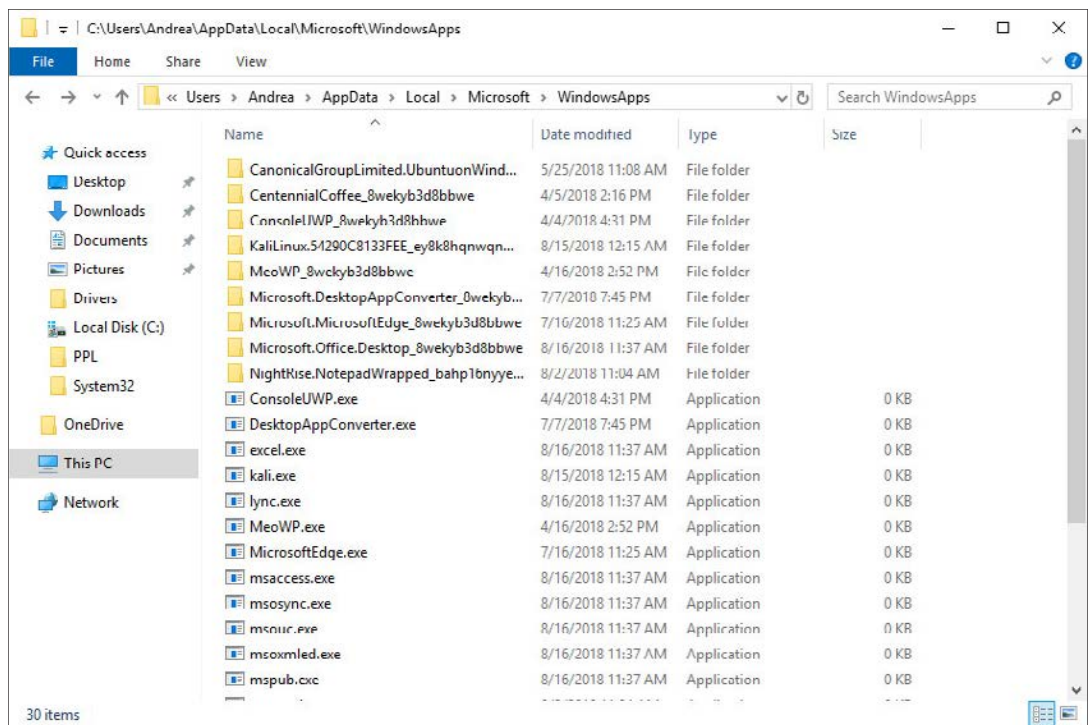

FIGURE 8-46 The AppExecution aliases main folder.

How can the system execute a 0-byte file? The answer lies in a little-known feature of the file system: reparse points. Reparse points are usually employed for symbolic links creation, but they can store any data, not only symbolic link information. The Modern Application Model uses this feature to store the packaged application's activation data (package family name, Application user model ID, and application path) directly into the reparse point.

When the user launches an AppExecution alias executable, the *CreateProcess* API is used as usual. The *NtCreateUserProcess* system call, used to orchestrate the kernel-mode process creation (see the “Flow of CreateProcess” section of Chapter 3 in Part 1, for details) fails because the content of the file is empty. The file system, as part of normal process creation, opens the target file (through *IoCreateFileEx* API), encounters the reparse point data (while parsing the last node of the path) and returns a *STATUS_REPARSE* code to the caller. *NtCreateUserProcess* translates this code to the *STATUS_IO_REPARSE_TAG_NOT_HANDLED* error and exits. The *CreateProcess* API now knows that the process creation has failed due to an invalid reparse point, so it loads and calls into the *ApiSetHost.AppExecutionAlias.dll* library, which contains code that parses modern applications’ reparse points.

The library’s code parses the reparse point, grabs the packaged application activation data, and calls into the AppInfo service with the goal of correctly stamping the token with the needed security attributes. AppInfo verifies that the user has the correct license for running the packaged application and checks the integrity of its files (through the State Repository). The actual process creation is done by the calling process. The *CreateProcess* API detects the reparse error and restarts its execution starting with the correct package executable path (usually located in *C:\Program Files\WindowsApps*). This time, it correctly creates the process and the AppContainer token or, in case of Centennial, initializes the virtualization layer (actually, in this case, another RPC into AppInfo is used again). Furthermore, it creates the HAM host and its activity, which are needed for the application. The activation at this point is complete.

EXPERIMENT: Reading the AppExecution alias data

In this experiment, you extract AppExecution alias data from the 0-bytes executable file. You can use the *FsReparser* utility (found in this book’s downloadable resources) to parse both the reparse points or the extended attributes of the NTFS file system. Just run the tool in a command prompt window and specify the *READ* command-line parameter:

```
C:\Users\Andrea\AppData\Local\Microsoft\WindowsApps>fsreparser read MicrosoftEdge.exe
```

```
File System Reparse Point / Extended Attributes Parser 0.1  
Copyright 2018 by Andrea Allievi (AaL186)
```

```
Reading UWP attributes...  
Source file: MicrosoftEdge.exe.
```

```
The source file does not contain any Extended Attributes.
```

```
The file contains a valid UWP Reparse point (version 3).  
Package family name: Microsoft.MicrosoftEdge_8wekyb3d8bbwe  
Application User Model Id: Microsoft.MicrosoftEdge_8wekyb3d8bbwe!MicrosoftEdge  
UWP App Target full path: C:\Windows\System32\SystemUWPLauncher.exe  
Alias Type: UWP Single Instance
```

As you can see from the output of the tool, the *CreateProcess* API can extract all the information that it needs to properly execute a modern application’s activation. This explains why you can launch Edge from the command line.

Package registration

When a user wants to install a modern application, usually she opens the AppStore, looks for the application, and clicks the Get button. This action starts the download of an archive that contains a bunch of files: the package manifest file, the application digital signature, and the block map, which represent the chain of trust of the certificates included in the digital signature. The archive is initially stored in the C:\Windows\SoftwareDistribution\Download folder. The AppStore process (WinStore.App.exe) communicates with the Windows Update service (wuaueng.dll), which manages the download requests.

The downloaded files are manifests that contain the list of all the modern application's files, the application dependencies, the license data, and the steps needed to correctly register the package. The Windows Update service recognizes that the download request is for a modern application, verifies the calling process token (which should be an AppContainer), and, using services provided by the AppXDeploymentClient.dll library, verifies that the package is not already installed in the system. It then creates an AppX Deployment request and, through RPC, sends it to the AppX Deployment Server. The latter runs as a PPL service in a shared service host process (which hosts even the Client License Service, running as the same protected level). The Deployment Request is placed into a queue, which is managed asynchronously. When the AppX Deployment Server sees the request, it dequeues it and spawns a thread that starts the actual modern application deployment process.



Note Starting with Windows 8.1, the UWP deployment stack supports the concept of *bundles*. Bundles are packages that contain multiple resources, like different languages or features that have been designed only for certain regions. The deployment stack implements an applicability logic that can download only the needed part of the compressed bundle after checking the user profile and system settings.

A modern application deployment process involves a complex sequence of events. We summarize here the entire deployment process in three main phases.

Phase 1: Package staging

After Windows Update has downloaded the application manifest, the AppX Deployment Server verifies that all the package dependencies are satisfied, checks the application prerequisites, like the target supported device family (Phone, Desktop, Xbox, and so on) and checks whether the file system of the target volume is supported. All the prerequisites that the application needs are expressed in the manifest file with each dependency. If all the checks pass, the staging procedure creates the package root directory (usually in C:\Program Files\WindowsApps*<PackageFullName>*) and its subfolders. Furthermore, it protects the package folders, applying proper ACLs on all of them. If the modern application is a Centennial type, it loads the daxexec.dll library and creates VFS reparse points needed by the Windows Container Isolation minifilter driver (see the "Centennial applications" section earlier in this chapter) with the goal of virtualizing the application data folder properly. It finally saves the package root path into the HKLM\SOFTWARE\Classes\LocalSettings\Software\Microsoft\Windows\CurrentVersion\AppModel\PackageRepository\Packages*<PackageFullName>* registry key, in the *Path* registry value.

The staging procedure then preallocates the application's files on disk, calculates the final download size, and extracts the server URL that contains all the package files (compressed in an AppX file). It finally downloads the final AppX from the remote servers, again using the Windows Update service.

Phase 2: User data staging

This phase is executed only if the user is updating the application. This phase simply restores the user data of the previous package and stores them in the new application path.

Phase 3: Package registration

The most important phase of the deployment is the package registration. This complex phase uses services provided by AppXDeploymentExtensions.onecore.dll library (and AppXDeploymentExtensions.desktop.dll for desktop-specific deployment parts). We refer to it as Package Core Installation. At this stage, the AppX Deployment Server needs mainly to update the State Repository. It creates new entries for the package, for the one or more applications that compose the package, the new tiles, package capabilities, application license, and so on. To do this, the AppX Deployment server uses database transactions, which it finally commits only if no previous errors occurred (otherwise, they will be discarded). When all the database transactions that compose a State Repository deployment operation are committed, the State Repository can call the registered listeners, with the goal of notifying each client that has requested a notification. (See the "State Repository" section in this chapter for more information about the change and event tracking feature of the State Repository.)

The last steps for the package registration include creating the Dependency Mini Repository file and updating the machine registry to reflect the new data stored in the State Repository. This terminates the deployment process. The new application is now ready to be activated and run.



Note For readability reasons, the deployment process has been significantly simplified. For example, in the described staging phase, we have omitted some initial subphases, like the Indexing phase, which parses the AppX manifest file; the Dependency Manager phase, used to create a work plan and analyze the package dependencies; and the Package In Use phase, which has the goal of communicating with PLM to verify that the package is not already installed and in use.

Furthermore, if an operation fails, the deployment stack must be able to revert all the changes. The other revert phases have not been described in the previous section.

Conclusion

In this chapter, we have examined the key base system mechanisms on which the Windows executive is built. In the next chapter, we introduce the virtualization technologies that Windows supports with the goal of improving the overall system security, providing a fast execution environment for virtual machines, isolated containers, and secure enclaves.

Virtualization technologies

One of the most important technologies used for running multiple operating systems on the same physical machine is virtualization. At the time of this writing, there are multiple types of virtualization technologies available from different hardware manufacturers, which have evolved over the years. Virtualization technologies are not only used for running multiple operating systems on a physical machine, but they have also become the basics for important security features like the Virtual Secure Mode (VSM) and Hypervisor-Enforced Code Integrity (HVCI), which can't be run without a hypervisor.

In this chapter, we give an overview of the Windows virtualization solution, called Hyper-V. Hyper-V is composed of the hypervisor, which is the component that manages the platform-dependent virtualization hardware, and the virtualization stack. We describe the internal architecture of Hyper-V and provide a brief description of its components (memory manager, virtual processors, intercepts, scheduler, and so on). The virtualization stack is built on the top of the hypervisor and provides different services to the root and guest partitions. We describe all the components of the virtualization stack (VM Worker process, virtual machine management service, VID driver, VMBus, and so on) and the different hardware emulation that is supported.

In the last part of the chapter, we describe some technologies based on the virtualization, such as VSM and HVCI. We present all the secure services that those technologies provide to the system.

The Windows hypervisor

The Hyper-V hypervisor (also known as Windows hypervisor) is a type-1 (native or bare-metal) hypervisor: a mini operating system that runs directly on the host's hardware to manage a single root and one or more guest operating systems. Unlike type-2 (or hosted) hypervisors, which run on the base of a conventional OS like normal applications, the Windows hypervisor abstracts the root OS, which knows about the existence of the hypervisor and communicates with it to allow the execution of one or more guest virtual machines. Because the hypervisor is part of the operating system, managing the guests inside it, as well as interacting with them, is fully integrated in the operating system through standard management mechanisms such as WMI and services. In this case, the root OS contains some *enlightenments*. Enlightenments are special optimizations in the kernel and possibly device drivers that detect that the code is being run virtualized under a hypervisor, so they perform certain tasks differently, or more efficiently, considering this environment.

Figure 9-1 shows the basic architecture of the Windows virtualization stack, which is described in detail later in this chapter.

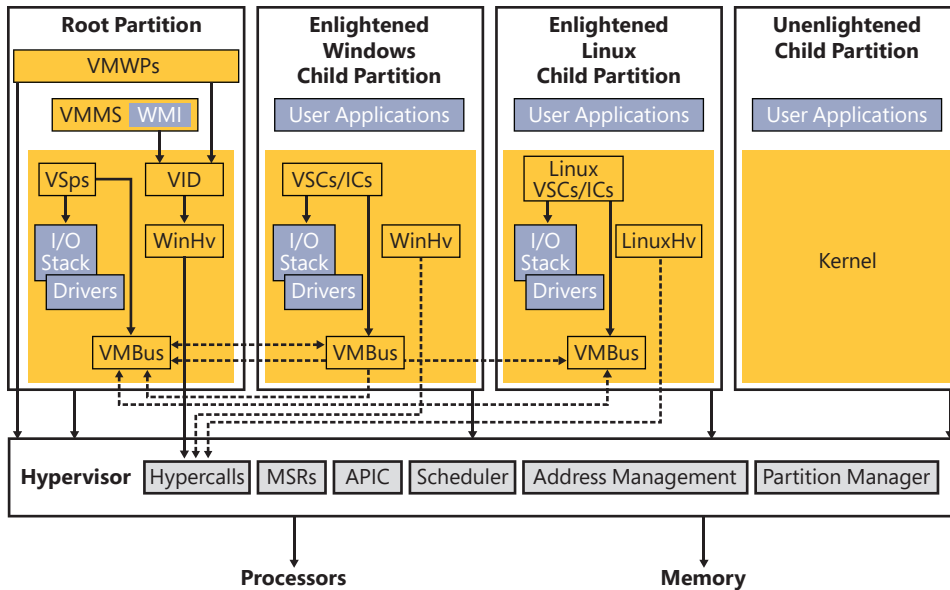

FIGURE 9-1 The Hyper-V architectural stack (hypervisor and virtualization stack).

At the bottom of the architecture is the hypervisor, which is launched very early during the system boot and provides its services for the virtualization stack to use (through the use of the hypercall interface). The early initialization of the hypervisor is described in Chapter 12, “Startup and shutdown.” The hypervisor startup is initiated by the Windows Loader, which determines whether to start the hypervisor and the Secure Kernel; if the hypervisor and Secure Kernel are started, the hypervisor uses the services of the Hvloader.dll to detect the correct hardware platform and load and start the proper version of the hypervisor. Because Intel and AMD (and ARM64) processors have differing implementations of hardware-assisted virtualization, there are different hypervisors. The correct one is selected at boot-up time after the processor has been queried through CPUID instructions. On Intel systems, the Hvix64.exe binary is loaded; on AMD systems, the Hvax64.exe image is used. As of the Windows 10 May 2019 Update (19H1), the ARM64 version of Windows supports its own hypervisor, which is implemented in the Hvaa64.exe image.

At a high level, the hardware virtualization extension used by the hypervisor is a thin layer that resides between the OS kernel and the processor. This layer, which intercepts and emulates in a safe manner sensitive operations executed by the OS, is run in a higher privilege level than the OS kernel. (Intel calls this mode VMXROOT. Most books and literature define the VMXROOT security domain as “Ring -1.”) When an operation executed by the underlying OS is intercepted, the processor stops to run the OS code and transfer the execution to the hypervisor at the higher privilege level. This operation is commonly referred to as a VMEXIT event. In the same way, when the hypervisor has finished processing the intercepted operation, it needs a way to allow the physical CPU to restart the execution of the OS code. New opcodes have been defined by the hardware virtualization extension, which allow a VMENTER event to happen; the CPU restarts the execution of the OS code at its original privilege level.

Partitions, processes, and threads

One of the key architectural components behind the Windows hypervisor is the concept of a partition. A partition essentially represents the main isolation unit, an instance of an operating system installation, which can refer either to what's traditionally called the host or the guest. Under the Windows hypervisor model, these two terms are not used; instead, we talk of either a root partition or a child partition, respectively. A partition is composed of some physical memory and one or more virtual processors (VPs) with their local virtual APICs and timers. (In the global term, a partition also includes a virtual motherboard and multiple virtual peripherals. These are virtualization stack concepts, which do not belong to the hypervisor.)

At a minimum, a Hyper-V system has a root partition—in which the main operating system controlling the machine runs—the virtualization stack, and its associated components. Each operating system running within the virtualized environment represents a child partition, which might contain certain additional tools that optimize access to the hardware or allow management of the operating system. Partitions are organized in a hierarchical way. The root partition has control of each child and receives some notifications (intercepts) for certain kinds of events that happen in the child. The majority of the physical hardware accesses that happen in the root are passed through by the hypervisor; this means that the parent partition is able to talk directly to the hardware (with some exceptions). As a counterpart, child partitions are usually not able to communicate directly with the physical machine's hardware (again with some exceptions, which are described later in this chapter in the section “The virtualization stack”). Each I/O is intercepted by the hypervisor and redirected to the root if needed.

One of the main goals behind the design of the Windows hypervisor was to have it be as small and modular as possible, much like a microkernel—no need to support any *hypervisor driver* or provide a full, monolithic module. This means that most of the virtualization work is actually done by a separate virtualization stack (refer to Figure 9-1). The hypervisor uses the existing Windows driver architecture and talks to actual Windows device drivers. This architecture results in several components that provide and manage this behavior, which are collectively called the *virtualization stack*. Although the hypervisor is read from the boot disk and executed by the Windows Loader before the root OS (and the parent partition) even exists, it is the parent partition that is responsible for providing the entire virtualization stack. Because these are Microsoft components, only a Windows machine can be a root partition. The Windows OS in the root partition is responsible for providing the device drivers for the hardware on the system, as well as for running the virtualization stack. It's also the management point for all the child partitions. The main components that the root partition provides are shown in Figure 9-2.

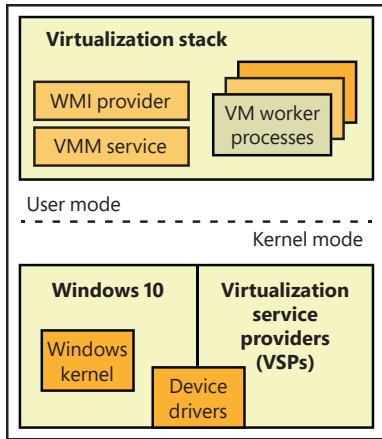

FIGURE 9-2 Components of the root partition.

Child partitions

A child partition is an instance of any operating system running parallel to the parent partition. (Because you can save or pause the state of any child, it might not necessarily be running.) Unlike the parent partition, which has full access to the APIC, I/O ports, and its physical memory (but not access to the hypervisor’s and Secure Kernel’s physical memory), child partitions are limited for security and management reasons to their own view of address space (the Guest Physical Address, or GPA, space, which is managed by the hypervisor) and have no direct access to hardware (even though they may have direct access to certain kinds of devices; see the “Virtualization stack” section for further details). In terms of hypervisor access, a child partition is also limited mainly to notifications and state changes. For example, a child partition doesn’t have control over other partitions (and can’t create new ones).

Child partitions have many fewer virtualization components than a parent partition because they aren’t responsible for running the virtualization stack—only for communicating with it. Also, these components can also be considered optional because they enhance performance of the environment but aren’t critical to its use. Figure 9-3 shows the components present in a typical Windows child partition.

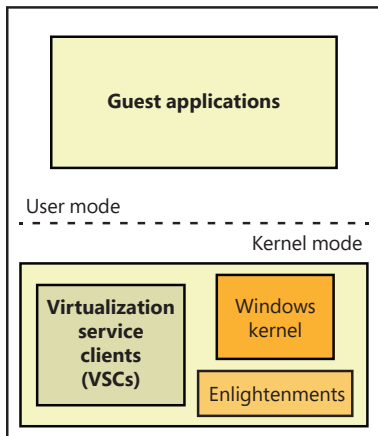

FIGURE 9-3 Components of a child partition.

Processes and threads

The Windows hypervisor represents a virtual machine with a partition data structure. A partition, as described in the previous section, is composed of some memory (guest physical memory) and one or more virtual processors (VP). Internally in the hypervisor, each virtual processor is a schedulable entity, and the hypervisor, like the standard NT kernel, includes a scheduler. The scheduler dispatches the execution of virtual processors, which belong to different partitions, to each physical CPU. (We discuss the multiple types of hypervisor schedulers later in this chapter in the “Hyper-V schedulers” section.) A hypervisor thread (*TH_THREAD* data structure) is the glue between a virtual processor and its schedulable unit. Figure 9-4 shows the data structure, which represents the current physical execution context. It contains the thread execution stack, scheduling data, a pointer to the thread’s virtual processor, the entry point of the thread dispatch loop (discussed later) and, most important, a pointer to the hypervisor process that the thread belongs to.

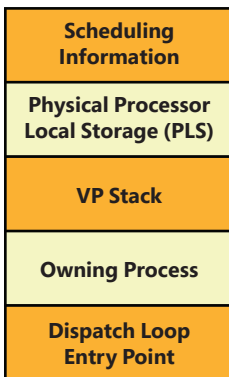

FIGURE 9-4 The hypervisor’s thread data structure.

The hypervisor builds a thread for each virtual processor it creates and associates the newborn thread with the virtual processor data structure (*VM_VP*).

A hypervisor process (*TH_PROCESS* data structure), shown in Figure 9-5, represents a partition and is a container for its physical (and virtual) address space. It includes the list of the threads (which are backed by virtual processors), scheduling data (the physical CPUs affinity in which the process is allowed to run), and a pointer to the partition basic memory data structures (memory compartment, reserved pages, page directory root, and so on). A process is usually created when the hypervisor builds the partition (*VM_PARTITION* data structure), which will represent the new virtual machine.

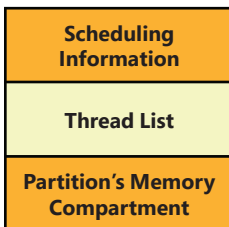

FIGURE 9-5 The hypervisor’s process data structure.

Enlightenments

Enlightenments are one of the key performance optimizations that Windows virtualization takes advantage of. They are direct modifications to the standard Windows kernel code that can detect that the operating system is running in a child partition and perform work differently. Usually, these optimizations are highly hardware-specific and result in a hypercall to notify the hypervisor.

An example is notifying the hypervisor of a long busy-wait spin loop. The hypervisor can keep some state on the spin wait and decide to schedule another VP on the same physical processor until the wait can be satisfied. Entering and exiting an interrupt state and access to the APIC can be coordinated with the hypervisor, which can be enlightened to avoid trapping the real access and then virtualizing it.

Another example has to do with memory management, specifically translation lookaside buffer (TLB) flushing. (See Part 1, Chapter 5, “Memory management,” for more information on these concepts.) Usually, the operating system executes a CPU instruction to flush one or more stale TLB entries, which affects only a single processor. In multiprocessor systems, usually a TLB entry must be flushed from every active processor’s cache (the system sends an inter-processor interrupt to every active processor to achieve this goal). However, because a child partition could be sharing physical CPUs with many other child partitions, and some of them could be executing a different VM’s virtual processor at the time the TLB flush is initiated, such an operation would also flush this information for those VMs. Furthermore, a virtual processor would be rescheduled to execute only the TLB flushing IPI, resulting in noticeable performance degradation. If Windows is running under a hypervisor, it instead issues a hypercall to have the hypervisor flush only the specific information belonging to the child partition.

Partition’s privileges, properties, and version features

When a partition is initially created (usually by the VID driver), no virtual processors (VPs) are associated with it. At that time, the VID driver is free to add or remove some partition’s privileges. Indeed, when the partition is first created, the hypervisor assigns some default privileges to it, depending on its type.

A partition’s *privilege* describes which action—usually expressed through hypercalls or synthetic MSRs (model specific registers)—the enlightened OS running inside a partition is allowed to perform on behalf of the partition itself. For example, the Access Root Scheduler privilege allows a child partition to notify the root partition that an event has been signaled and a guest’s VP can be rescheduled (this usually increases the priority of the guest’s VP-backed thread). The Access VSM privilege instead allows the partition to enable VTL 1 and access its properties and configuration (usually exposed through synthetic registers). Table 9-1 lists all the privileges assigned by default by the hypervisor.

Partition *privileges* can only be set before the partition creates and starts any VPs; the hypervisor won’t allow requests to set privileges after a single VP in the partition starts to execute. Partition *properties* are similar to privileges but do not have this limitation; they can be set and queried at any time. There are different groups of properties that can be queried or set for a partition. Table 9-2 lists the properties groups.

When a partition is created, the VID infrastructure provides a compatibility level (which is specified in the virtual machine’s configuration file) to the hypervisor. Based on that compatibility level, the hypervisor enables or disables specific virtual hardware features that could be exposed by a VP to the underlying OS. There are multiple features that tune how the VP behaves based on the VM’s compatibility

level. A good example would be the hardware Page Attribute Table (PAT), which is a configurable caching type for virtual memory. Prior to Windows 10 Anniversary Update (RS1), guest VMs weren't able to use PAT in guest VMs, so regardless of whether the compatibility level of a VM specifies Windows 10 RS1, the hypervisor will not expose the PAT registers to the underlying guest OS. Otherwise, in case the compatibility level is higher than Windows 10 RS1, the hypervisor exposes the PAT support to the underlying OS running in the guest VM. When the root partition is initially created at boot time, the hypervisor enables the highest compatibility level for it. In that way the root OS can use all the features supported by the physical hardware.

TABLE 9-1 Partition's privileges

PARTITION TYPE	DEFAULT PRIVILEGES
Root and child partition	<ul style="list-style-type: none"> Read/write a VP's runtime counter Read the current partition reference time Access SynIC timers and registers Query/set the VP's virtual APIC assist page Read/write hypercall MSRs Request VP IDLE entry Read VP's index Map or unmap the hypercall's code area Read a VP's emulated TSC (time-stamp counter) and its frequency Control the partition TSC and re-enlightenment emulation Read/write VSM synthetic registers Read/write VP's per-VTL registers Starts an AP virtual processor Enables partition's fast hypercall support
Root partition only	<ul style="list-style-type: none"> Create child partition Look up and reference a partition by ID Deposit/withdraw memory from the partition compartment Post messages to a connection port Signal an event in a connection port's partition Create/delete and get properties of a partition's connection port Connect/disconnect to a partition's connection port Map/unmap the hypervisor statistics page (which describe a VP, LP, partition, or hypervisor) Enable the hypervisor debugger for the partition Schedule child partition's VPs and access SynIC synthetic MSRs Trigger an enlightened system reset Read the hypervisor debugger options for a partition
Child partition only	<ul style="list-style-type: none"> Generate an extended hypercall intercept in the root partition Notify a root scheduler's VP-backed thread of an event being signaled
EXO partition	None

TABLE 9-2 Partition's properties

PROPERTY GROUP	DESCRIPTION
Scheduling properties	Set/query properties related to the classic and core scheduler, like Cap, Weight, and Reserve
Time properties	Allow the partition to be suspended/resumed
Debugging properties	Change the hypervisor debugger runtime configuration
Resource properties	Queries virtual hardware platform-specific properties of the partition (like TLB size, SGX support, and so on)
Compatibility properties	Queries virtual hardware platform-specific properties that are tied to the initial compatibility features

The hypervisor startup

In Chapter 12, we analyze the modality in which a UEFI-based workstation boots up, and all the components engaged in loading and starting the correct version of the hypervisor binary. In this section, we briefly discuss what happens in the machine after the HvLoader module has transferred the execution to the hypervisor, which takes control for the first time.

The HvLoader loads the correct version of the hypervisor binary image (depending on the CPU manufacturer) and creates the hypervisor loader block. It captures a minimal processor context, which the hypervisor needs to start the first virtual processor. The HvLoader then switches to a new, just-created, address space and transfers the execution to the hypervisor image by calling the hypervisor image entry point, *KiSystemStartup*, which prepares the processor for running the hypervisor and initializes the *CPU_PLS* data structure. The *CPU_PLS* represents a physical processor and acts as the *PRCB* data structure of the NT kernel; the hypervisor is able to quickly address it (using the GS segment). Differently from the NT kernel, *KiSystemStartup* is called only for the boot processor (the application processors startup sequence is covered in the “Application Processors (APs) Startup” section later in this chapter), thus it defers the real initialization to another function, *BmplnitBootProcessor*.

BmplnitBootProcessor starts a complex initialization sequence. The function examines the system and queries all the CPU’s supported virtualization features (such as the EPT and VPID; the queried features are platform-specific and vary between the Intel, AMD, or ARM version of the hypervisor). It then determines the hypervisor scheduler, which will manage how the hypervisor will schedule virtual processors. For Intel and AMD server systems, the default scheduler is the core scheduler, whereas the root scheduler is the default for all client systems (including ARM64). The scheduler type can be manually overridden through the *hypervisorsschedulertype* BCD option (more information about the different hypervisor schedulers is available later in this chapter).

The nested enlightenments are initialized. Nested enlightenments allow the hypervisor to be executed in nested configurations, where a root hypervisor (called L0 hypervisor), manages the real hardware, and another hypervisor (called L1 hypervisor) is executed in a virtual machine. After this stage, the *BmplnitBootProcessor* routine performs the initialization of the following components:

- Memory manager (initializes the PFN database and the root compartment).
- The hypervisor’s hardware abstraction layer (HAL).
- The hypervisor’s process and thread subsystem (which depends on the chosen scheduler type). The system process and its initial thread are created. This process is special; it isn’t tied to any partition and hosts threads that execute the hypervisor code.
- The VMX virtualization abstraction layer (VAL). The VAL’s purpose is to abstract differences between all the supported hardware virtualization extensions (Intel, AMD, and ARM64). It includes code that operates on platform-specific features of the machine’s virtualization technology in use by the hypervisor (for example, on the Intel platform the VAL layer manages the “unrestricted guest” support, the EPT, SGX, MBEC, and so on).
- The Synthetic Interrupt Controller (SynIC) and I/O Memory Management Unit (IOMMU).

- The Address Manager (AM), which is the component responsible for managing the physical memory assigned to a partition (called guest physical memory, or GPA) and its translation to real physical memory (called system physical memory). Although the first implementation of Hyper-V supported shadow page tables (a software technique for address translation), since Windows 8.1, the Address manager uses platform-dependent code for configuring the hypervisor address translation mechanism offered by the hardware (extended page tables for Intel, nested page tables for AMD). In hypervisor terms, the physical address space of a partition is called *address domain*. The platform-independent physical address space translation is commonly called Second Layer Address Translation (SLAT). The term refers to the Intel's EPT, AMD's NPT or ARM 2-stage address translation mechanism.

The hypervisor can now finish constructing the *CPU_PLS* data structure associated with the boot processor by allocating the initial hardware-dependent virtual machine control structures (VMCS for Intel, VMCB for AMD) and by enabling virtualization through the first VMXON operation. Finally, the per-processor interrupt mapping data structures are initialized.

EXPERIMENT: Connecting the hypervisor debugger

In this experiment, you will connect the hypervisor debugger for analyzing the startup sequence of the hypervisor, as discussed in the previous section. The hypervisor debugger is supported only via serial or network transports. Only physical machines can be used to debug the hypervisor, or virtual machines in which the “nested virtualization” feature is enabled (see the “Nested virtualization” section later in this chapter). In the latter case, only serial debugging can be enabled for the L1 virtualized hypervisor.

For this experiment, you need a separate physical machine that supports virtualization extensions and has the Hyper-V role installed and enabled. You will use this machine as the debugged system, attached to your host system (which acts as the debugger) where you are running the debugging tools. As an alternative, you can set up a nested VM, as shown in the “Enabling nested virtualization on Hyper-V” experiment later in this chapter (in that case you don't need another physical machine).

As a first step, you need to download and install the “Debugging Tools for Windows” in the host system, which are available as part of the Windows SDK (or WDK), downloadable from <https://developer.microsoft.com/en-us/windows/downloads/windows-10-sdk>. As an alternative, for this experiment you also can use the WinDbgX, which, at the time of this writing, is available in the Windows Store by searching “WinDbg Preview.”

The debugged system for this experiment must have Secure Boot disabled. The hypervisor debugging is not compatible with Secure Boot. Refer to your workstation user manual for understanding how to disable Secure Boot (usually the Secure Boot settings are located in the UEFI Bios). For enabling the hypervisor debugger in the debugged system, you should first open an administrative command prompt (by typing **cmd** in the Cortana search box and selecting **Run as administrator**).

In case you want to debug the hypervisor through your network card, you should type the following commands, replacing the terms *<HostIp>* with the IP address of the host system; *<HostPort>* with a valid port in the host (from 49152); and *<NetCardBusParams>* with the bus parameters of the network card of the debugged system, specified in the XX.YY.ZZ format (where XX is the bus number, YY is the device number, and ZZ is the function number). You can discover the bus parameters of your network card through the Device Manager applet or through the KDNET.exe tool available in the Windows SDK:

```
bcdedit /hypervisorsettings net hostip:<HostIp> port:<HostPort>
bcdedit /set {hypervisorsettings} hypervisordebugpages 1000
bcdedit /set {hypervisorsettings} hypervisorbusparams <NetCardBusParams>
bcdedit /set hypervisordebug on
```

The following figure shows a sample system in which the network interface used for debugging the hypervisor is located in the 0.25.0 bus parameters, and the debugger is targeting a host system configured with the IP address 192.168.0.56 on the port 58010.

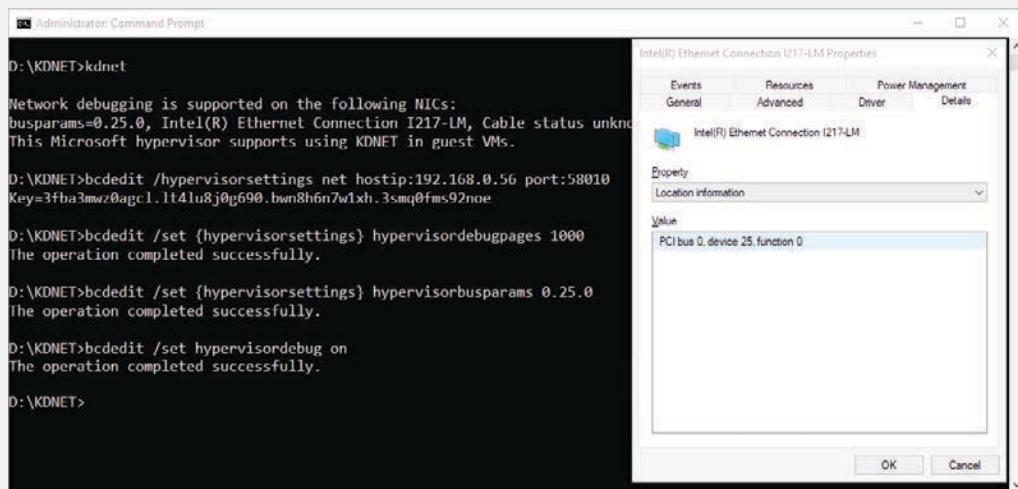

Take note of the returned debugging key. After you reboot the debugged system, you should run Windbg in the host, with the following command:

```
windbg.exe -d -k net:port=<HostPort>,key=<DebuggingKey>
```

You should be able to debug the hypervisor, and follow its startup sequence, even though Microsoft may not release the symbols for the main hypervisor module:

Finally, after the SynIC, IOMMU, and the intercepts' shared pages are correctly configured for the partition, the hypervisor creates and starts the BSP virtual processor for the root partition, which is the unique one used to restart the boot process.

A hypervisor virtual processor (VP) is represented by a big data structure (*VM_VP*), shown in Figure 9-6. A *VM_VP* data structure maintains all the data used to track the state of the virtual processor: its platform-dependent registers state (like general purposes, debug, XSAVE area, and stack) and data, the VP's private address space, and an array of *VM_VPLC* data structures, which are used to track the state of each Virtual Trust Level (VTL) of the virtual processor. The *VM_VP* also includes a pointer to the VP's backing thread and a pointer to the physical processor that is currently executing the VP.

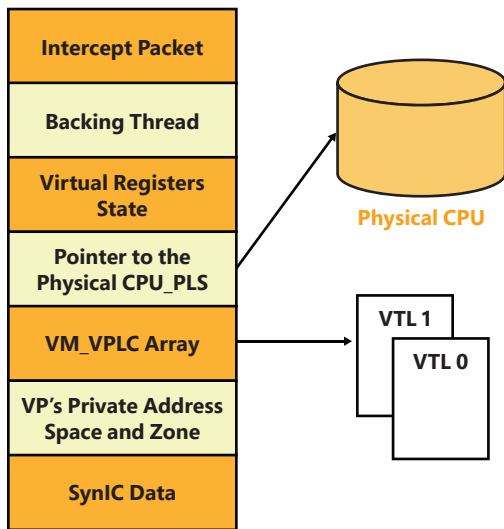

FIGURE 9-6 The *VM_VP* data structure representing a virtual processor.

As for the partitions, creating the BSP virtual processor is similar to the process of creating normal virtual processors. *VmAllocateVp* is the function responsible in allocating and initializing the needed memory from the partition's compartment, used for storing the *VM_VP* data structure, its platform-dependent part, and the *VM_VPLC* array (one for each supported VTL). The hypervisor copies the initial processor context, specified by the HvLoader at boot time, into the *VM_VP* structure and then creates the VP's private address space and attaches to it (only in case address space isolation is enabled). Finally, it creates the VP's backing thread. This is an important step: the construction of the virtual processor continues in the context of its own backing thread. The hypervisor's main system thread at this stage waits until the new BSP VP is completely initialized. The wait brings the hypervisor scheduler to select the newly created thread, which executes a routine, *ObConstructVp*, that constructs the VP in the context of the new backed thread.

ObConstructVp, in a similar way as for partitions, constructs and initializes each layer of the virtual processor—in particular, the following:

1. The Virtualization Manager (VM) layer attaches the physical processor data structure (*CPU_PLS*) to the VP and sets VTL 0 as active.

2. The VAL layer initializes the platform-dependent portions of the VP, like its registers, XSAVE area, stack, and debug data. Furthermore, for each supported VTL, it allocates and initializes the VMCS data structure (VMCB for AMD systems), which is used by the hardware for keeping track of the state of the virtual machine, and the VTL's SLAT page tables. The latter allows each VTL to be isolated from each other (more details about VTLs are provided later in the "Virtual Trust Levels (VTLs) and Virtual Secure Mode (VSM)" section). Finally, the VAL layer enables and sets VTL 0 as active. The platform-specific VMCS (or VMCB for AMD systems) is entirely compiled, the SLAT table of VTL 0 is set as active, and the real-mode emulator is initialized. The Host-state part of the VMCS is set to target the hypervisor VAL dispatch loop. This routine is the most important part of the hypervisor because it manages all the VMEXIT events generated by each guest.
3. The VP layer allocates the VP's hypercall page, and, for each VTL, the assist and intercept message pages. These pages are used by the hypervisor for sharing code or data with the guest operating system.

When *ObConstructVp* finishes its work, the VP's dispatch thread activates the virtual processor and its synthetic interrupt controller (SynIC). If the VP is the first one of the root partition, the dispatch thread restores the initial VP's context stored in the *VM_VP* data structure by writing each captured register in the platform-dependent VMCS (or VMCB) processor area (the context has been specified by the HvLoader earlier in the boot process). The dispatch thread finally signals the completion of the VP initialization (as a result, the main system thread enters the idle loop) and enters the platform-dependent VAL dispatch loop. The VAL dispatch loop detects that the VP is new, prepares it for the first execution, and starts the new virtual machine by executing a VMLAUNCH instruction. The new VM restarts exactly at the point at which the HvLoader has transferred the execution to the hypervisor. The boot process continues normally but in the context of the new hypervisor partition.

The hypervisor memory manager

The hypervisor memory manager is relatively simple compared to the memory manager for NT or the Secure Kernel. The entity that manages a set of physical memory pages is the hypervisor's *memory compartment*. Before the hypervisor startup takes place, the hypervisor loader (Hvloader.dll) allocates the hypervisor loader block and pre-calculates the maximum number of physical pages that will be used by the hypervisor for correctly starting up and creating the root partition. The number depends on the pages used to initialize the IOMMU to store the memory range structures, the system PFN database, SLAT page tables, and HAL VA space. The hypervisor loader preallocates the calculated number of physical pages, marks them as reserved, and attaches the page list array in the loader block. Later, when the hypervisor starts, it creates the root compartment by using the page list that was allocated by the hypervisor loader.

Figure 9-7 shows the layout of the memory compartment data structure. The data structure keeps track of the total number of physical pages "deposited" in the compartment, which can be allocated somewhere or freed. A compartment stores its physical pages in different lists ordered by the NUMA node. Only the head of each list is stored in the compartment. The state of each physical page and its link in the NUMA list is maintained thanks to the entries in the PFN database. A compartment also

tracks its relationship with the root. A new compartment can be created using the physical pages that belongs to the parent (the root). Similarly, when the compartment is deleted, all its remaining physical pages are returned to the parent.

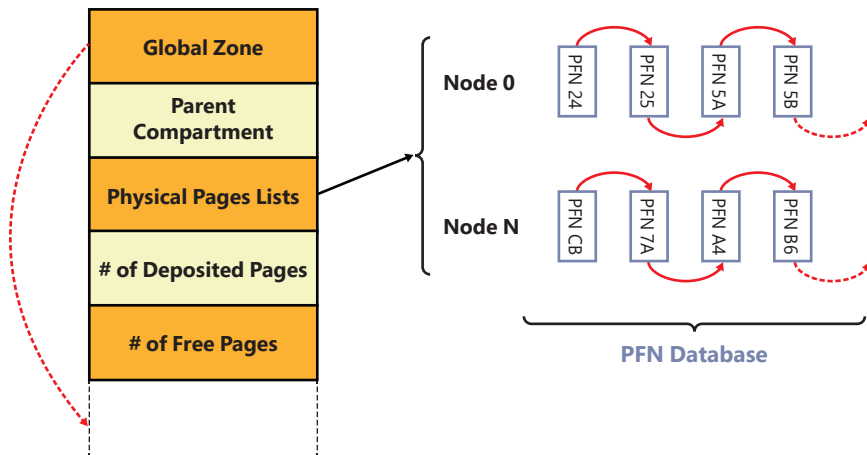

FIGURE 9-7 The hypervisor’s memory compartment. Virtual address space for the global zone is reserved from the end of the compartment data structure

When the hypervisor needs some physical memory for any kind of work, it allocates from the active compartment (depending on the partition). This means that the allocation can fail. Two possible scenarios can arise in case of failure:

- If the allocation has been requested for a service internal to the hypervisor (usually on behalf of the root partition), the failure should not happen, and the system is crashed. (This explains why the initial calculation of the total number of pages to be assigned to the root compartment needs to be accurate.)
- If the allocation has been requested on behalf of a child partition (usually through a hypercall), the hypervisor will fail the request with the status *INSUFFICIENT_MEMORY*. The root partition detects the error and performs the allocation of some physical page (more details are discussed later in the “Virtualization stack” section), which will be deposited in the child compartment through the *HvDepositMemory* hypercall. The operation can be finally reinitiated (and usually will succeed).

The physical pages allocated from the compartment are usually mapped in the hypervisor using a virtual address. When a compartment is created, a virtual address range (sized 4 or 8 GB, depending on whether the compartment is a root or a child) is allocated with the goal of mapping the new compartment, its PDE bitmap, and its global zone.

A hypervisor’s zone encapsulates a private VA range, which is not shared with the entire hypervisor address space (see the “Isolated address space” section later in this chapter). The hypervisor executes with a single root page table (differently from the NT kernel, which uses KVA shadowing). Two entries in the root page table page are reserved with the goal of dynamically switching between each zone and the virtual processors’ address spaces.

Partitions' physical address space

As discussed in the previous section, when a partition is initially created, the hypervisor allocates a physical address space for it. A physical address space contains all the data structures needed by the hardware to translate the partition's guest physical addresses (GPAs) to system physical addresses (SPAs). The hardware feature that enables the translation is generally referred to as second level address translation (SLAT). The term SLAT is platform-agnostic: hardware vendors use different names: Intel calls it EPT for extended page tables; AMD uses the term NPT for nested page tables; and ARM simply calls it Stage 2 Address Translation.

The SLAT is usually implemented in a way that's similar to the implementation of the x64 page tables, which uses four levels of translation (the x64 virtual address translation has already been discussed in detail in Chapter 5 of Part 1). The OS running inside the partition uses the same virtual address translation as if it were running by bare-metal hardware. However, in the former case, the physical processor actually executes two levels of translation: one for virtual addresses and one for translating physical addresses. Figure 9-8 shows the SLAT set up for a guest partition. In a guest partition, a GPA is usually translated to a different SPA. This is not true for the root partition.

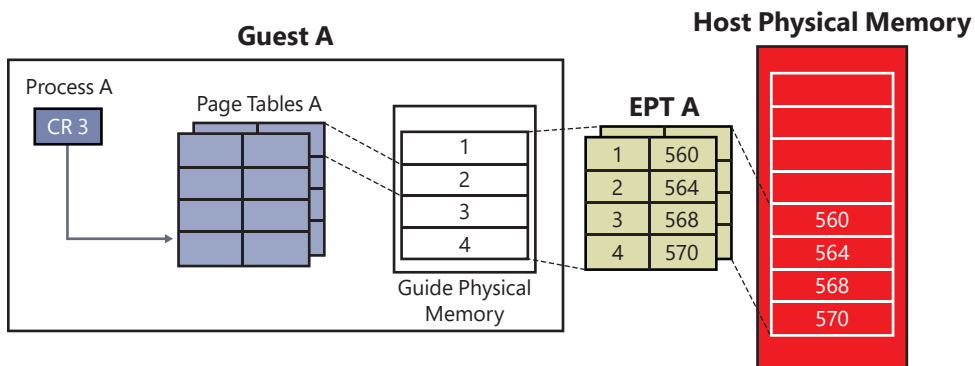

FIGURE 9-8 Address translation for a guest partition.

When the hypervisor creates the root partition, it builds its initial physical address space by using identity mapping. In this model, each GPA corresponds to the same SPA (for example, guest frame 0x1000 in the root partition is mapped to the bare-metal physical frame 0x1000). The hypervisor pre-allocates the memory needed for mapping the entire physical address space of the machine (which has been discovered by the Windows Loader using UEFI services; see Chapter 12 for details) into all the allowed root partition's virtual trust levels (VTLs). (The root partition usually supports two VTLs.) The SLAT page tables of each VTL belonging to the partition include the same GPA and SPA entries but usually with a different protection level set. The protection level applied to each partition's physical frame allows the creation of different security domains (VTL), which can be isolated one from each other. VTLs are explained in detail in the section "The Secure Kernel" later in this chapter. The hypervisor pages are marked as hardware-reserved and are not mapped in the partition's SLAT table (actually they are mapped using an invalid entry pointing to a dummy PFN).



Note For performance reasons, the hypervisor, while building the physical memory mapping, is able to detect large chunks of contiguous physical memory, and, in a similar way as for virtual memory, is able to map those chunks by using large pages. If for some reason the OS running in the partition decides to apply a more granular protection to the physical page, the hypervisor would use the reserved memory for breaking the large page in the SLAT table.

Earlier versions of the hypervisor also supported another technique for mapping a partition's physical address space: shadow paging. Shadow paging was used for those machines without the SLAT support. This technique had a very high-performance overhead; as a result, it's not supported anymore. (The machine must support SLAT; otherwise, the hypervisor would refuse to start.)

The SLAT table of the root is built at partition-creation time, but for a guest partition, the situation is slightly different. When a child partition is created, the hypervisor creates its initial physical address space but allocates only the root page table (PML4) for each partition's VTL. Before starting the new VM, the VID driver (part of the virtualization stack) reserves the physical pages needed for the VM (the exact number depends on the VM memory size) by allocating them from the root partition. (Remember, we are talking about physical memory; only a driver can allocate physical pages.) The VID driver maintains a list of physical pages, which is analyzed and split in large pages and then is sent to the hypervisor through the *HvMapGpaPages* Rep hypercall.

Before sending the map request, the VID driver calls into the hypervisor for creating the needed SLAT page tables and internal physical memory space data structures. Each SLAT page table hierarchy is allocated for each available VTL in the partition (this operation is called *pre-commit*). The operation can fail, such as when the new partition's compartment could not contain enough physical pages. In this case, as discussed in the previous section, the VID driver allocates more memory from the root partition and deposits it in the child's partition compartment. At this stage, the VID driver can freely map all the child's partition physical pages. The hypervisor builds and compiles all the needed SLAT page tables, assigning different protection based on the VTL level. (Large pages require one less indirection level.) This step concludes the child partition's physical address space creation.

Address space isolation

Speculative execution vulnerabilities discovered in modern CPUs (also known as Meltdown, Spectre, and Foreshadow) allowed an attacker to read secret data located in a more privileged execution context by speculatively reading the stale data located in the CPU cache. This means that software executed in a guest VM could potentially be able to speculatively read private memory that belongs to the hypervisor or to the more privileged root partition. The internal details of the Spectre, Meltdown, and all the side-channel vulnerabilities and how they are mitigated by Windows have been covered in detail in Chapter 8.

The hypervisor has been able to mitigate most of these kinds of attacks by implementing the HyperClear mitigation. The HyperClear mitigation relies on three key components to ensure strong Inter-VM isolation: core scheduler, Virtual-Processor Address Space Isolation, and sensitive data scrubbing. In modern multicore CPUs, often different SMT threads share the same CPU cache. (Details about the core scheduler and symmetric multithreading are provided in the “Hyper-V schedulers” section.) In the virtualization environment, SMT threads on a core can independently enter and exit the hypervisor context based on their activity. For example, events like interrupts can cause an SMT thread to switch out of running the guest virtual processor context and begin executing the hypervisor context. This can happen independently for each SMT thread, so one SMT thread may be executing in the hypervisor context while its sibling SMT thread is still running a VM’s guest virtual processor context. An attacker running code in a less trusted guest VM’s virtual processor context on one SMT thread can then use a side channel vulnerability to potentially observe sensitive data from the hypervisor context running on the sibling SMT thread.

The hypervisor provides strong data isolation to protect against a malicious guest VM by maintaining separate virtual address ranges for each guest SMT thread (which back a virtual processor). When the hypervisor context is entered on a specific SMT thread, no secret data is addressable. The only data that can be brought into the CPU cache is associated with that current guest virtual processor or represent shared hypervisor data. As shown in Figure 9-9, when a VP running on an SMT thread enters the hypervisor, it is enforced (by the root scheduler) that the sibling LP is running another VP that belongs to the same VM. Furthermore, no shared secrets are mapped in the hypervisor. In case the hypervisor needs to access secret data, it assures that no other VP is scheduled in the other sibling SMT thread.

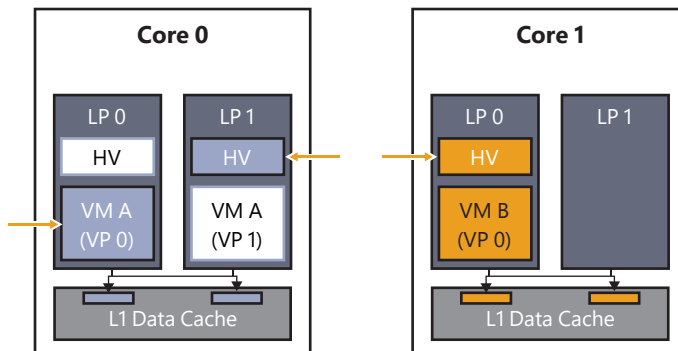

FIGURE 9-9 The Hyperclear mitigation.

Unlike the NT kernel, the hypervisor always runs with a single page table root, which creates a single global virtual address space. The hypervisor defines the concept of private address space, which has a misleading name. Indeed, the hypervisor reserves two global root page table entries (PML4 entries, which generate a 1-TB virtual address range) for mapping or unmapping a private address space. When the hypervisor initially constructs the VP, it allocates two private page table root entries. Those will be used to map the VP’s secret data, like its stack and data structures that contain private data. Switching the address space means writing the two entries in the global page table root (which explains why the term *private address space* has a misleading name—actually it is private address *range*). The hypervisor switches private address spaces only in two cases: when a new virtual processor is created and during

thread switches. (Remember, threads are backed by VPs. The core scheduler assures that no sibling SMT threads execute VPs from different partitions.) During runtime, a hypervisor thread has mapped only its own VP's private data; no other secret data is accessible by that thread.

Mapping secret data in the private address space is achieved by using the memory zone, represented by an MM_ZONE data structure. A memory zone encapsulates a private VA subrange of the private address space, where the hypervisor usually stores per-VP's secrets.

The memory zone works similarly to the private address space. Instead of mapping root page table entries in the global page table root, a memory zone maps private page directories in the two root entries used by the private address space. A memory zone maintains an array of page directories, which will be mapped and unmapped into the private address space, and a bitmap that keeps track of the used page tables. Figure 9-10 shows the relationship between a private address space and a memory zone. Memory zones can be mapped and unmapped on demand (in the private address space) but are usually switched only at VP creation time. Indeed, the hypervisor does not need to switch them during thread switches; the private address space encapsulates the VA range exposed by the memory zone.

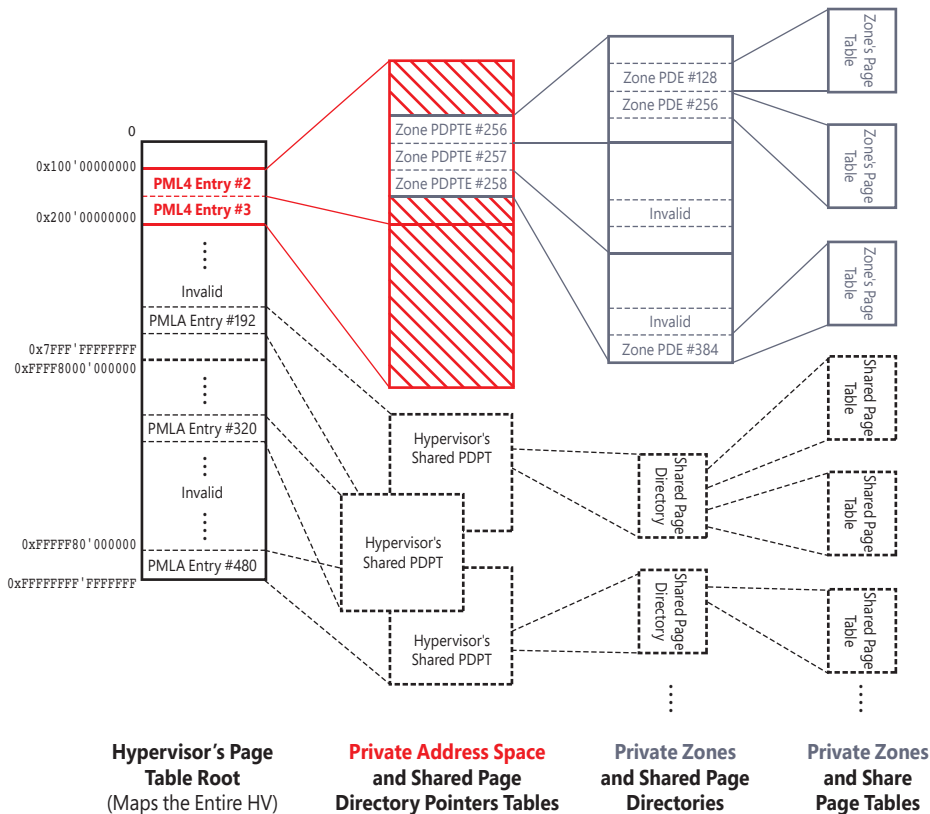

FIGURE 9-10 The hypervisor's private address spaces and private memory zones.

In Figure 9-10, the page table's structures related to the private address space are filled with a pattern, the ones related to the memory zone are shown in gray, and the shared ones belonging to the hypervisor are drawn with a dashed line. Switching private address spaces is a relatively cheap operation that requires the modification of two PML4 entries in the hypervisor's page table root. Attaching or detaching a memory zone from the private address space requires only the modification of the zone's PDPTPE (a zone VA size is variable; the PDTPE are always allocated contiguously).

Dynamic memory

Virtual machines can use a different percentage of their allocated physical memory. For example, some virtual machines use only a small amount of their assigned guest physical memory, keeping a lot of it freed or zeroed. The performance of other virtual machines can instead suffer for high-memory pressure scenarios, where the page file is used too often because the allocated guest physical memory is not enough. With the goal to prevent the described scenario, the hypervisor and the virtualization stack supports the concept of dynamic memory. *Dynamic memory* is the ability to dynamically assign and remove physical memory to a virtual machine. The feature is provided by multiple components:

- The NT kernel's memory manager, which supports hot add and hot removal of physical memory (on bare-metal system too)
- The hypervisor, through the SLAT (managed by the address manager)
- The VM Worker process, which uses the dynamic memory controller module, `Vmdynmem.dll`, to establish a connection to the VMBus Dynamic Memory VSC driver (`Dmvmc.sys`), which runs in the child partition

To properly describe dynamic memory, we should quickly introduce how the page frame number (PFN) database is created by the NT kernel. The PFN database is used by Windows to keep track of physical memory. It was discussed in detail in Chapter 5 of Part 1. For creating the PFN database, the NT kernel first calculates the hypothetical size needed to map the highest possible physical address (256 TB on standard 64-bit systems) and then marks the VA space needed to map it entirely as reserved (storing the base address to the `MmPfnDatabase` global variable). Note that the reserved VA space still has no page tables allocated. The NT kernel cycles between each physical memory descriptor discovered by the boot manager (using UEFI services), coalesces them in the longest ranges possible and, for each range, maps the underlying PFN database entries using large pages. This has an important implication; as shown in Figure 9-11, the PFN database has space for the highest possible amount of physical memory but only a small subset of it is mapped to real physical pages (this technique is called *sparse memory*).

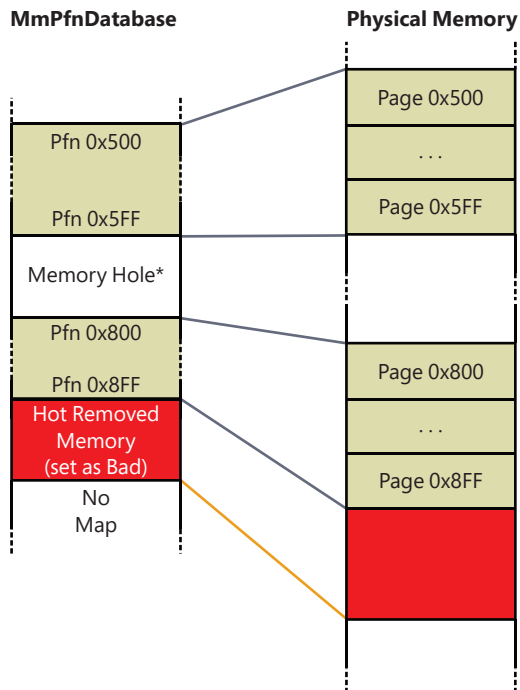

FIGURE 9-11 An example of a PFN database where some physical memory has been removed.

Hot add and removal of physical memory works thanks to this principle. When new physical memory is added to the system, the Plug and Play memory driver (Pnpmmem.sys) detects it and calls the *MmAddPhysicalMemory* routine, which is exported by the NT kernel. The latter starts a complex procedure that calculates the exact number of pages in the new range and the Numa node to which they belong, and then it maps the new PFN entries in the database by creating the necessary page tables in the reserved VA space. The new physical pages are added to the free list (see Chapter 5 in Part 1 for more details).

When some physical memory is hot removed, the system performs an inverse procedure. It checks that the pages belong to the correct physical page list, updates the internal memory counters (like the total number of physical pages), and finally frees the corresponding PFN entries, meaning that they all will be marked as “bad.” The memory manager will never use the physical pages described by them anymore. No actual virtual space is unmapped from the PFN database. The physical memory that was described by the freed PFNs can always be re-added in the future.

When an enlightened VM starts, the dynamic memory driver (Dmvmc.sys) detects whether the child VM supports the hot add feature; if so, it creates a worker thread that negotiates the protocol and connects to the VMBus channel of the VSP. (See the “Virtualization stack” section later in this chapter for details about VSC and VSP.) The VMBus connection channel connects the dynamic memory driver running in the child partition to the dynamic memory controller module (Vmdynmem.dll), which is mapped in the VM Worker process in the root partition. A message exchange protocol is started. Every one second, the child partition acquires a memory pressure report by querying different performance counters exposed by the memory manager (global page-file usage; number of available, committed,

and dirty pages; number of page faults per seconds; number of pages in the free and zeroed page list). The report is then sent to the root partition.

The VM Worker process in the root partition uses the services exposed by the VMMS balancer, a component of the VmCompute service, for performing the calculation needed for determining the possibility to perform a hot add operation. If the memory status of the root partition allowed a hot add operation, the VMMS balancer calculates the proper number of pages to deposit in the child partition and calls back (through COM) the VM Worker process, which starts the hot add operation with the assistance of the VID driver:

1. Reserves the proper amount of physical memory in the root partition
2. Calls the hypervisor with the goal to map the system physical pages reserved by the root partition to some guest physical pages mapped in the child VM, with the proper protection
3. Sends a message to the dynamic memory driver for starting a hot add operation on some guest physical pages previously mapped by the hypervisor

The dynamic memory driver in the child partition uses the *MmAddPhysicalMemory* API exposed by the NT kernel to perform the hot add operation. The latter maps the PFNs describing the new guest physical memory in the PFN database, adding new backing pages to the database if needed.

In a similar way, when the VMMS balancer detects that the child VM has plenty of physical pages available, it may require the child partition (still through the VM Worker process) to hot remove some physical pages. The dynamic memory driver uses the *MmRemovePhysicalMemory* API to perform the hot remove operation. The NT kernel verifies that each page in the range specified by the balancer is either on the zeroed or free list, or it belongs to a stack that can be safely paged out. If all the conditions apply, the dynamic memory driver sends back the “hot removal” page range to the VM Worker process, which will use services provided by the VID driver to unmap the physical pages from the child partition and release them back to the NT kernel.



Note Dynamic memory is not supported when nested virtualization is enabled.

Hyper-V schedulers

The hypervisor is a kind of micro operating system that runs below the root partition's OS (Windows). As such, it should be able to decide which thread (backing a virtual processor) is being executed by which physical processor. This is especially true when the system runs multiple virtual machines composed in total by more virtual processors than the physical processors installed in the workstation. The hypervisor scheduler role is to select the next thread that a physical CPU is executing after the allocated time slice of the current one ends. Hyper-V can use three different schedulers. To properly manage all the different schedulers, the hypervisor exposes the *scheduler APIs*, a set of routines that are the only entries into the hypervisor scheduler. Their sole purpose is to redirect API calls to the particular scheduler implementation.

EXPERIMENT: Controlling the hypervisor's scheduler type

Whereas client editions of Windows start by default with the root scheduler, Windows Server 2019 runs by default with the core scheduler. In this experiment, you figure out the hypervisor scheduler enabled on your system and find out how to switch to another kind of hypervisor scheduler on the next system reboot.

The Windows hypervisor logs a system event after it has determined which scheduler to enable. You can search the logged event by using the Event Viewer tool, which you can run by typing **eventvwr** in the Cortana search box. After the applet is started, expand the **Windows Logs** key and click the **System log**. You should search for events with ID 2 and the Event sources set to Hyper-V-Hypervisor. You can do that by clicking the **Filter Current Log** button located on the right of the window or by clicking the **Event ID** column, which will order the events in ascending order by their ID (keep in mind that the operation can take a while). If you double-click a found event, you should see a window like the following:

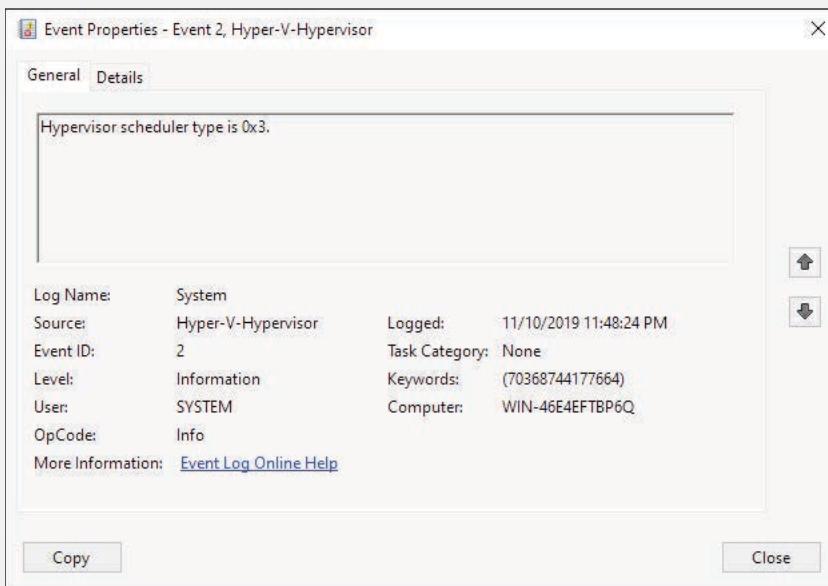

The launch event ID 2 denotes indeed the hypervisor scheduler type, where

- 1 = Classic scheduler, SMT disabled
- 2 = Classic scheduler
- 3 = Core scheduler
- 4 = Root scheduler

The sample figure was taken from a Windows Server system, which runs by default with the Core Scheduler. To change the scheduler type to the classic one (or root), you should open an administrative command prompt window (by typing **cmd** in the Cortana search box and selecting **Run As Administrator**) and type the following command:

```
bcdedit /set hypervisorschedulertype <Type>
```

where <Type> is Classic for the classic scheduler, Core for the core scheduler, or Root for the root scheduler. You should restart the system and check again the newly generated Hyper-V-Hypervisor event ID 2. You can also check the current enabled hypervisor scheduler by using an administrative PowerShell window with the following command:

```
Get-WinEvent -FilterHashTable @{ProviderName="Microsoft-Windows-Hyper-V-Hypervisor"; ID=2} -MaxEvents 1
```

The command extracts the last Event ID 2 from the System event log.

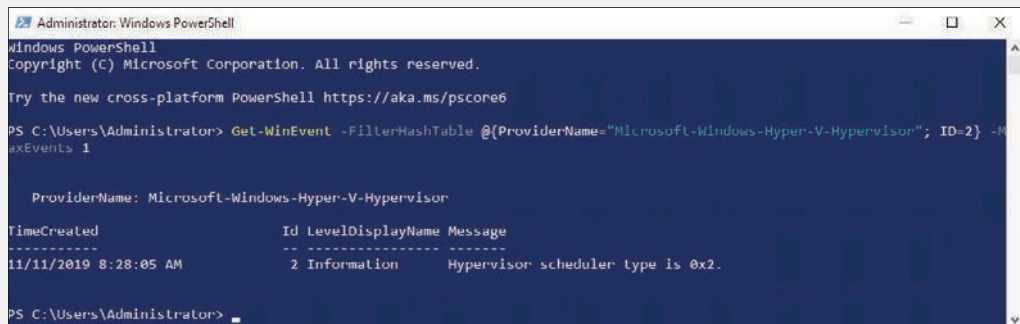

```
Administrator: Windows PowerShell
Windows PowerShell
Copyright (C) Microsoft Corporation. All rights reserved.

Try the new cross-platform PowerShell https://aka.ms/pscore6

PS C:\Users\Administrator> Get-WinEvent -FilterHashTable @{ProviderName="Microsoft-Windows-Hyper-V-Hypervisor"; ID=2} -MaxEvents 1

ProviderName: Microsoft-Windows-Hyper-V-Hypervisor

TimeCreated              Id LevelDisplayName Message
-----
11/11/2019 8:28:05 AM    2 Information      Hypervisor scheduler type is 0x2.

PS C:\Users\Administrator>
```

The classic scheduler

The classic scheduler has been the default scheduler used on all versions of Hyper-V since its initial release. The classic scheduler in its default configuration implements a simple, round-robin policy in which any virtual processor in the current execution state (the execution state depends on the total number of VMs running in the system) is equally likely to be dispatched. The classic scheduler supports also setting a virtual processor's affinity and performs scheduling decisions considering the physical processor's NUMA node. The classic scheduler doesn't know what a guest VP is currently executing. The only exception is defined by the spin-lock enlightenment. When the Windows kernel, which is running in a partition, is going to perform an active wait on a spin-lock, it emits a hypercall with the goal to inform the hypervisor (high IRQL synchronization mechanisms are described in Chapter 8, "System mechanisms"). The classic scheduler can preempt the current executing virtual processor (which hasn't expired its allocated time slice yet) and can schedule another one. In this way it saves the active CPU spin cycles.

The default configuration of the classic scheduler assigns an equal time slice to each VP. This means that in high-workload oversubscribed systems, where multiple virtual processors attempt to execute, and the physical processors are sufficiently busy, performance can quickly degrade. To overcome

the problem, the classic scheduler supports different fine-tuning options (see Figure 9-12), which can modify its internal scheduling decision:

- **VP reservations** A user can reserve the CPU capacity in advance on behalf of a guest machine. The reservation is specified as the percentage of the capacity of a physical processor to be made available to the guest machine whenever it is scheduled to run. As a result, Hyper-V schedules the VP to run only if that minimum amount of CPU capacity is available (meaning that the allocated time slice is guaranteed).
- **VP limits** Similar to VP reservations, a user can limit the percentage of physical CPU usage for a VP. This means reducing the available time slice allocated to a VP in a high workload scenario.
- **VP weight** This controls the probability that a VP is scheduled when the reservations have already been met. In default configurations, each VP has an equal probability of being executed. When the user configures weight on the VPs that belong to a virtual machine, scheduling decisions become based on the relative weighting factor the user has chosen. For example, let's assume that a system with four CPUs runs three virtual machines at the same time. The first VM has set a weighting factor of 100, the second 200, and the third 300. Assuming that all the system's physical processors are allocated to a uniform number of VPs, the probability of a VP in the first VM to be dispatched is 17%, of a VP in the second VM is 33%, and of a VP in the third one is 50%.

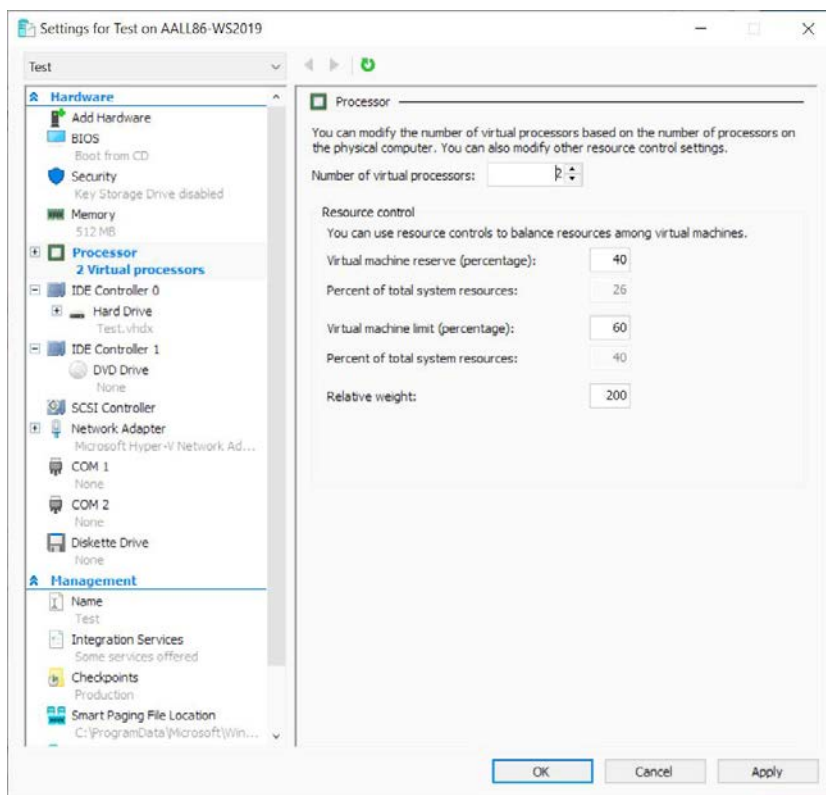

FIGURE 9-12 The classic scheduler fine-tuning settings property page, which is available only when the classic scheduler is enabled.

The core scheduler

Normally, a classic CPU's core has a single execution pipeline in which streams of instructions are executed one after each other. An instruction enters the pipe, proceeds through several stages of execution (load data, compute, store data, for example), and is retired from the pipe. Different types of instructions use different parts of the CPU core. A modern CPU's core is often able to execute in an out-of-order way multiple sequential instructions in the stream (in respect to the order in which they entered the pipeline). Modern CPUs, which support out-of-order execution, often implement what is called symmetric multithreading (SMT): a CPU's core has two execution pipelines and presents more than one logical processor to the system; thus, two different instruction streams can be executed side by side by a single shared execution engine. (The resources of the core, like its caches, are shared.) The two execution pipelines are exposed to the software as single independent processors (CPUs). From now on, with the term *logical processor* (or simply LP), we will refer to an execution pipeline of an SMT core exposed to Windows as an independent CPU. (SMT is discussed in Chapters 2 and 4 of Part 1.)

This hardware implementation has led to many security problems: one instruction executed by a shared logical CPU can interfere and affect the instruction executed by the other sibling LP. Furthermore, the physical core's cache memory is shared; an LP can alter the content of the cache. The other sibling CPU can potentially probe the data located in the cache by measuring the time employed by the processor to access the memory addressed by the same cache line, thus revealing "secret data" accessed by the other logical processor (as described in the "Hardware side-channel vulnerabilities" section of Chapter 8). The classic scheduler can normally select two threads belonging to different VMs to be executed by two LPs in the same processor core. This is clearly not acceptable because in this context, the first virtual machine could potentially read data belonging to the other one.

To overcome this problem, and to be able to run SMT-enabled VMs with predictable performance, Windows Server 2016 has introduced the core scheduler. The core scheduler leverages the properties of SMT to provide isolation and a strong security boundary for guest VPs. When the core scheduler is enabled, Hyper-V schedules virtual cores onto physical cores. Furthermore, it ensures that VPs belonging to different VMs are never scheduled on sibling SMT threads of a physical core. The core scheduler enables the virtual machine for making use of SMT. The VPs exposed to a VM can be part of an SMT set. The OS and applications running in the guest virtual machine can use SMT behavior and programming interfaces (APIs) to control and distribute work across SMT threads, just as they would when run nonvirtualized.

Figure 9-13 shows an example of an SMT system with four logical processors distributed in two CPU cores. In the figure, three VMs are running. The first and second VMs have four VPs in two groups of two, whereas the third one has only one assigned VP. The groups of VPs in the VMs are labelled A through E. Individual VPs in a group that are idle (have no code to execute) are filled with a darker color.

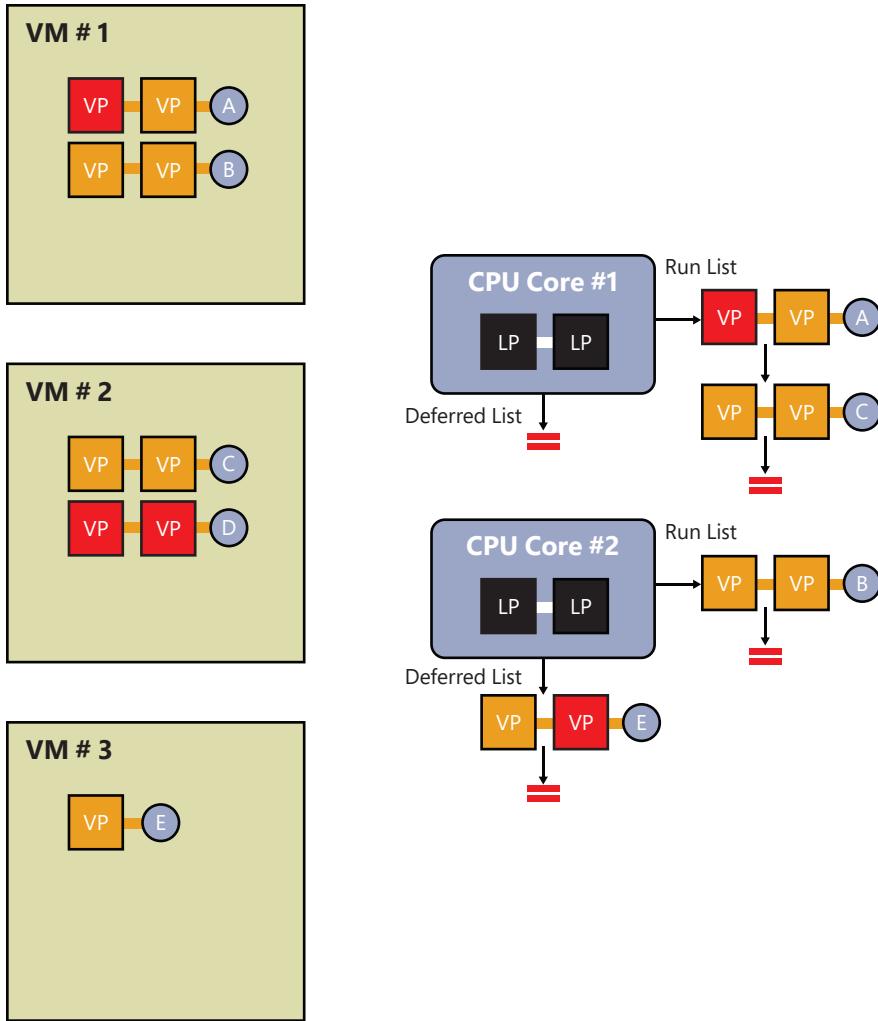

FIGURE 9-13 A sample SMT system with two processors' cores and three VMs running.

Each core has a run list containing groups of VPs that are ready to execute, and a deferred list of groups of VPs that are ready to run but have not been added to the core's run list yet. The groups of VPs execute on the physical cores. If all VPs in a group become idle, then the VP group is descheduled and does not appear on any run list. (In Figure 9-13, this is the situation for VP group D.) The only VP of the group E has recently left the idle state. The VP has been assigned to the CPU core 2. In the figure, a dummy sibling VP is shown. This is because the LP of core 2 never schedules any other VP while its sibling LP of its core is executing a VP belonging to the VM 3. In the same way, no other VPs are scheduled on a physical core if one VP in the LP group became idle but the other is still executing (such as for group A, for example). Each core executes the VP group that is at the head of its run list. If there are no VP groups to execute, the core becomes idle and waits for a VP group to be deposited onto its deferred run list. When this occurs, the core wakes up from idle and empties its deferred run list, placing the contents onto its run list.

The core scheduler is implemented by different components (see Figure 9-14) that provide strict layering between each other. The heart of the core scheduler is the *scheduling unit*, which represents a virtual core or group of SMT VPs. (For non-SMT VMs, it represents a single VP.) Depending on the VM's type, the scheduling unit has either one or two threads bound to it. The hypervisor's process owns a list of scheduling units, which own threads backing up to VPs belonging to the VM. The scheduling unit is the single unit of scheduling for the core scheduler to which scheduling settings—such as reservation, weight, and cap—are applied during runtime. A scheduling unit stays active for the duration of a time slice, can be blocked and unblocked, and can migrate between different physical processor cores. An important concept is that the scheduling unit is analogous to a thread in the classic scheduler, but it doesn't have a stack or VP context in which to run. It's one of the threads bound to a scheduling unit that runs on a physical processor core. The *thread gang scheduler* is the arbiter for each scheduling unit. It's the entity that decides which thread from the active scheduling unit gets run by which LP from the physical processor core. It enforces thread affinities, applies thread scheduling policies, and updates the related counters for each thread.

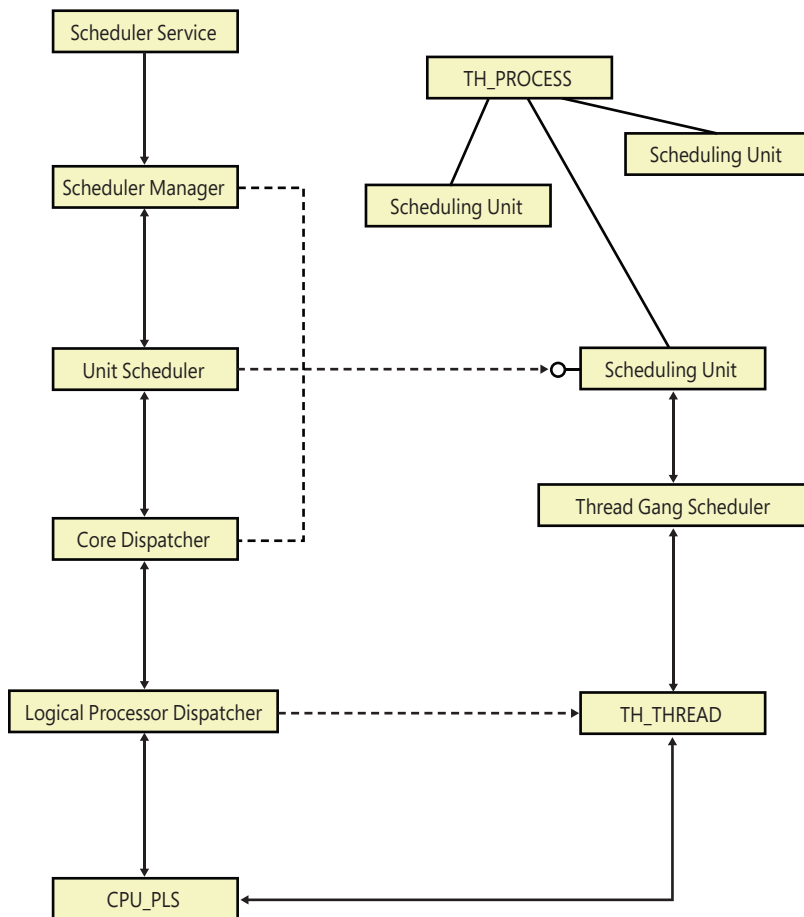

FIGURE 9-14 The components of the core scheduler.

Each LP of the physical processor's core has an instance of a logical processor dispatcher associated with it. The *logical processor dispatcher* is responsible for switching threads, maintaining timers, and flushing the VMCS (or VMCB, depending on the architecture) for the current thread. Logical processor dispatchers are owned by the *core dispatcher*, which represents a physical single processor core and owns exactly two SMT LPs. The core dispatcher manages the current (active) scheduling unit. The unit scheduler, which is bound to its own core dispatcher, decides which scheduling unit needs to run next on the physical processor core the unit scheduler belongs to. The last important component of the core scheduler is the *scheduler manager*, which owns all the unit schedulers in the system and has a global view of all their states. It provides load balancing and ideal core assignment services to the unit scheduler.

The root scheduler

The root scheduler (also known as integrated scheduler) was introduced in Windows 10 April 2018 Update (RS4) with the goal to allow the root partition to schedule virtual processors (VPs) belonging to guest partitions. The root scheduler was designed with the goal to support lightweight containers used by Windows Defender Application Guard. Those types of containers (internally called Barcelona or Krypton containers) must be managed by the root partition and should consume a small amount of memory and hard-disk space. (Deeply describing Krypton containers is outside the scope of this book. You can find an introduction of server containers in Part 1, Chapter 3, "Processes and jobs"). In addition, the root OS scheduler can readily gather metrics about workload CPU utilization inside the container and use this data as input to the same scheduling policy applicable to all other workloads in the system.

The NT scheduler in the root partition's OS instance manages all aspects of scheduling work to system LPs. To achieve that, the integrated scheduler's root component inside the VID driver creates a VP-dispatch thread inside of the root partition (in the context of the new VMMEM process) for each guest VP. (VA-backed VMs are discussed later in this chapter.) The NT scheduler in the root partition schedules VP-dispatch threads as regular threads subject to additional VM/VP-specific scheduling policies and enlightenments. Each VP-dispatch thread runs a VP-dispatch loop until the VID driver terminates the corresponding VP.

The VP-dispatch thread is created by the VID driver after the VM Worker Process (VMWP), which is covered in the "Virtualization stack" section later in this chapter, has requested the partition and VPs creation through the *SETUP_PARTITION* IOCTL. The VID driver communicates with the WinHvr driver, which in turn initializes the hypervisor's guest partition creation (through the *HvCreatePartition* hypercall). In case the created partition represents a VA-backed VM, or in case the system has the root scheduler active, the VID driver calls into the NT kernel (through a kernel extension) with the goal to create the VMMEM minimal process associated with the new guest partition. The VID driver also creates a VP-dispatch thread for each VP belonging to the partition. The VP-dispatch thread executes in the context of the VMMEM process in kernel mode (no user mode code exists in VMMEM) and is implemented in the VID driver (and WinHvr). As shown in Figure 9-15, each VP-dispatch thread runs a VP-dispatch loop until the VID terminates the corresponding VP or an intercept is generated from the guest partition.

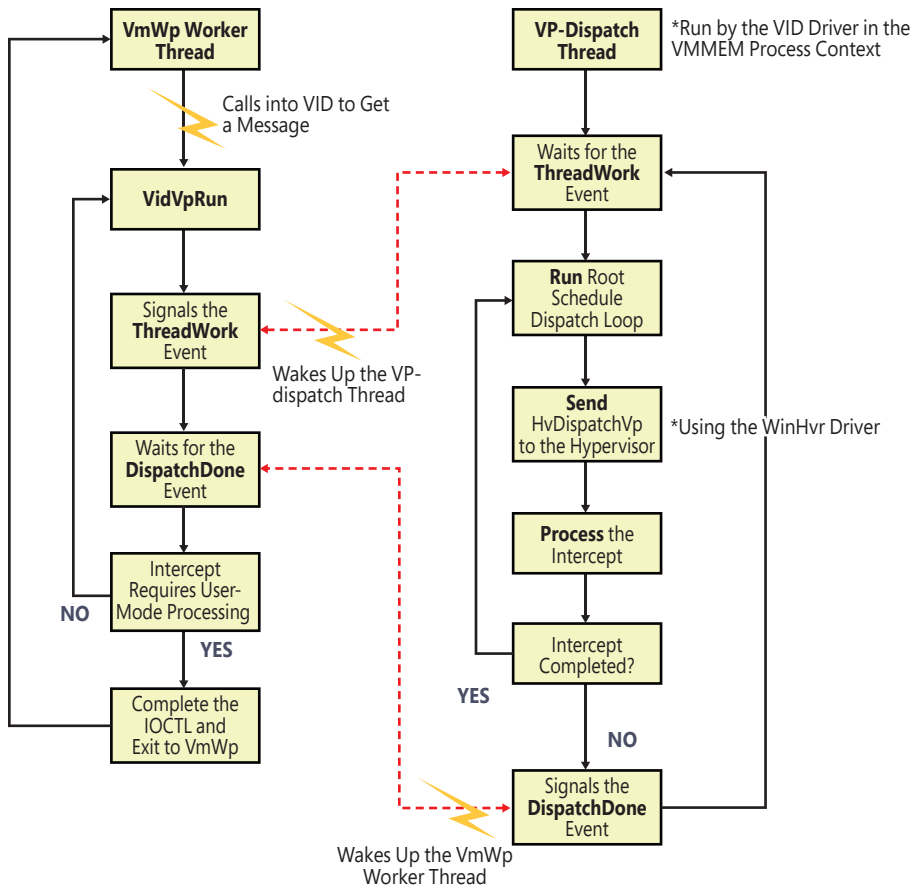

FIGURE 9-15 The root scheduler’s VP-dispatch thread and the associated VMWP worker thread that processes the hypervisor’s messages.

While in the VP-dispatch loop, the VP-dispatch thread is responsible for the following:

1. Call the hypervisor’s new *HvDispatchVp* hypercall interface to dispatch the VP on the current processor. On each *HvDispatchVp* hypercall, the hypervisor tries to switch context from the current root VP to the specified guest VP and let it run the guest code. One of the most important characteristics of this hypercall is that the code that emits it should run at *PASSIVE_LEVEL* IRQL. The hypervisor lets the guest VP run until either the VP blocks voluntarily, the VP generates an intercept for the root, or there is an interrupt targeting the root VP. Clock interrupts are still processed by the root partitions. When the guest VP exhausts its allocated time slice, the VP-backing thread is preempted by the NT scheduler. On any of the three events, the hypervisor switches back to the root VP and completes the *HvDispatchVp* hypercall. It then returns to the root partition.

2. Block on the VP-dispatch event if the corresponding VP in the hypervisor is blocked. Anytime the guest VP is blocked voluntarily, the VP-dispatch thread blocks itself on a VP-dispatch event until the hypervisor unblocks the corresponding guest VP and notifies the VID driver. The VID driver signals the VP-dispatch event, and the NT scheduler unblocks the VP-dispatch thread that can make another `HvDispatchVp` hypercall.
3. Process all intercepts reported by the hypervisor on return from the dispatch hypercall. If the guest VP generates an intercept for the root, the VP-dispatch thread processes the intercept request on return from the `HvDispatchVp` hypercall and makes another `HvDispatchVp` request after the VID completes processing of the intercept. Each intercept is managed differently. If the intercept requires processing from the user mode VMWP process, the `WinHvr` driver exits the loop and returns to the VID, which signals an event for the backed VMWP thread and waits for the intercept message to be processed by the VMWP process before restarting the loop.

To properly deliver signals to VP-dispatch threads from the hypervisor to the root, the integrated scheduler provides a scheduler message exchange mechanism. The hypervisor sends scheduler messages to the root partition via a shared page. When a new message is ready for delivery, the hypervisor injects a SINT interrupt into the root, and the root delivers it to the corresponding ISR handler in the `WinHvr` driver, which routes the message to the VID intercept callback (`VidInterceptIsrCallback`). The intercept callback tries to handle the intercept message directly from the VID driver. In case the direct handling is not possible, a synchronization event is signaled, which allows the dispatch loop to exit and allows one of the `VmWp` worker threads to dispatch the intercept in user mode.

Context switches when the root scheduler is enabled are more expensive compared to other hypervisor scheduler implementations. When the system switches between two guest VPs, for example, it always needs to generate two exits to the root partitions. The integrated scheduler treats hypervisor's root VP threads and guest VP threads very differently (they are internally represented by the same `TH_THREAD` data structure, though):

- Only the root VP thread can enqueue a guest VP thread to its physical processor. The root VP thread has priority over any guest VP that is running or being dispatched. If the root VP is not blocked, the integrated scheduler tries its best to switch the context to the root VP thread as soon as possible.
- A guest VP thread has two sets of states: *thread internal states* and *thread root states*. The thread root states reflect the states of the VP-dispatch thread that the hypervisor communicates to the root partition. The integrated scheduler maintains those states for each guest VP thread to know when to send a wake-up signal for the corresponding VP-dispatch thread to the root.

Only the root VP can initiate a dispatch of a guest VP for its processor. It can do that either because of `HvDispatchVp` hypercalls (in this situation, we say that the hypervisor is processing "external work"), or because of any other hypercall that requires sending a synchronous request to the target guest VP (this is what is defined as "internal work"). If the guest VP last ran on the current physical processor, the

scheduler can dispatch the guest VP thread right away. Otherwise, the scheduler needs to send a flush request to the processor on which the guest VP last ran and wait for the remote processor to flush the VP context. The latter case is defined as “migration” and is a situation that the hypervisor needs to track (through the thread internal states and root states, which are not described here).

EXPERIMENT: Playing with the root scheduler

The NT scheduler decides when to select and run a virtual processor belonging to a VM and for how long. This experiment demonstrates what we have discussed previously: All the VP dispatch threads execute in the context of the VMMEM process, created by the VID driver. For the experiment, you need a workstation with at least Windows 10 April 2018 update (RS4) installed, along with the Hyper-V role enabled and a VM with any operating system installed ready for use. The procedure for creating a VM is explained in detail here: <https://docs.microsoft.com/en-us/virtualization/hyper-v-on-windows/quick-start/quick-create-virtual-machine>.

First, you should verify that the root scheduler is enabled. Details on the procedure are available in the “Controlling the hypervisor’s scheduler type” experiment earlier in this chapter. The VM used for testing should be powered down.

Open the Task Manager by right-clicking on the task bar and selecting **Task Manager**, click the **Details** sheet, and verify how many VMMEM processes are currently active. In case no VMs are running, there should be none of them; in case the Windows Defender Application Guard (WDAG) role is installed, there could be an existing VMMEM process instance, which hosts the preloaded WDAG container. (This kind of VM is described later in the “VA-backed virtual machines” section.) In case a VMMEM process instance exists, you should take note of its process ID (PID).

Open the Hyper-V Manager by typing **Hyper-V Manager** in the Cortana search box and start your virtual machine. After the VM has been started and the guest operating system has successfully booted, switch back to the Task Manager and search for a new VMMEM process. If you click the new VMMEM process and expand the **User Name** column, you can see that the process has been associated with a token owned by a user named as the VM’s GUID. You can obtain your VM’s GUID by executing the following command in an administrative PowerShell window (replace the term “<VmName>” with the name of your VM):

```
Get-VM -VmName "<VmName>" | ft VMName, VmId
```

The VM ID and the VMMEM process's user name should be the same, as shown in the following figure.

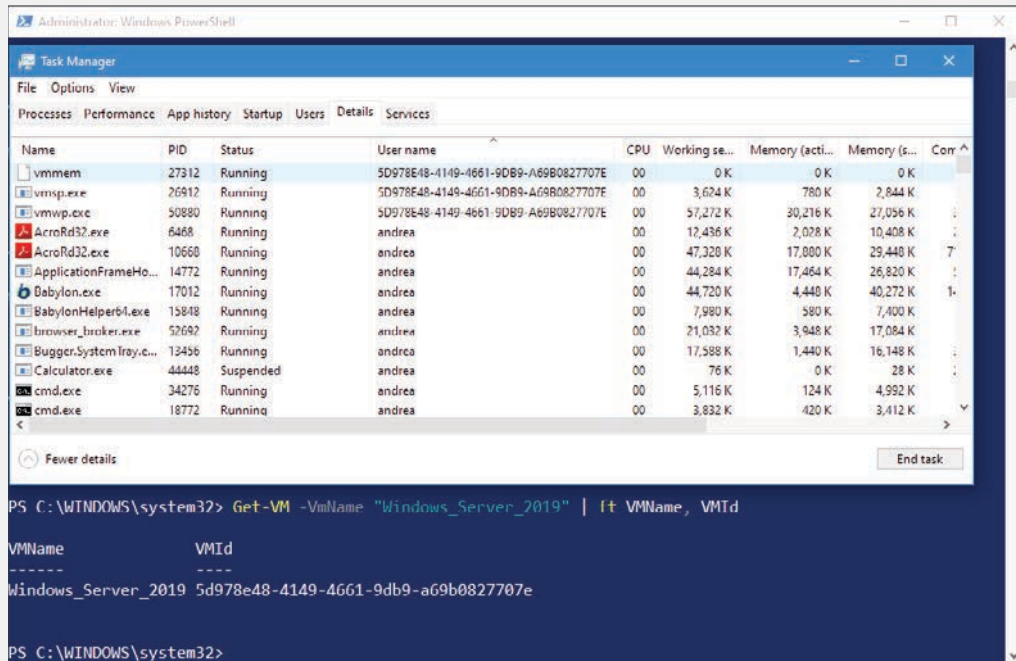

Install Process Explorer (by downloading it from <https://docs.microsoft.com/en-us/sysinternals/downloads/process-explorer>), and run it as administrator. Search the PID of the correct VMMEM process identified in the previous step (27312 in the example), right-click it, and select **Suspend**. The CPU tab of the VMMEM process should now show "Suspended" instead of the correct CPU time.

If you switch back to the VM, you will find that it is unresponsive and completely stuck. This is because you have suspended the process hosting the dispatch threads of all the virtual processors belonging to the VM. This prevented the NT kernel from scheduling those threads, which won't allow the WinHvr driver to emit the needed *HvDispatchVp* hypercall used to resume the VP execution.

If you right-click the suspended VMMEM and select **Resume**, your VM resumes its execution and continues to run correctly.

Hypercalls and the hypervisor TLFS

Hypercalls provide a mechanism to the operating system running in the root or the in the child partition to request services from the hypervisor. Hypercalls have a well-defined set of input and output parameters. The hypervisor Top Level Functional Specification (TLFS) is available online (<https://docs.microsoft.com/en-us/virtualization/hyper-v-on-windows/reference/tlfs>); it defines the different calling conventions used while specifying those parameters. Furthermore, it lists all the publicly available hypervisor features, partition's properties, hypervisor, and VSM interfaces.

Hypercalls are available because of a platform-dependent opcode (VMCALL for Intel systems, VMMSCALL for AMD, HVC for ARM64) which, when invoked, always cause a VM_EXIT into the hypervisor. VM_EXITs are events that cause the hypervisor to restart to execute its own code in the hypervisor privilege level, which is higher than any other software running in the system (except for firmware's SMM context), while the VP is suspended. VM_EXIT events can be generated from various reasons. In the platform-specific VMCS (or VMCB) opaque data structure the hardware maintains an index that specifies the exit reason for the VM_EXIT. The hypervisor gets the index, and, in case of an exit caused by a hypercall, reads the hypercall input value specified by the caller (generally from a CPU's general-purpose register—RCX in the case of 64-bit Intel and AMD systems). The hypercall input value (see Figure 9-16) is a 64-bit value that specifies the hypercall code, its properties, and the calling convention used for the hypercall. Three kinds of calling conventions are available:

- **Standard hypercalls** Store the input and output parameters on 8-byte aligned guest physical addresses (GPAs). The OS passes the two addresses via general-purposes registers (RDX and R8 on Intel and AMD 64-bit systems).
- **Fast hypercalls** Usually don't allow output parameters and employ the two general-purpose registers used in standard hypercalls to pass only input parameters to the hypervisor (up to 16 bytes in size).
- **Extended fast hypercalls** (or XMM fast hypercalls) Similar to fast hypercalls, but these use an additional six floating-point registers to allow the caller to pass input parameters up to 112 bytes in size.

63:60	59:48	47:44	43:32	31:27	26:17	16	15:0
RsvdZ (4 bits)	Rep start index (12 bits)	RsvdZ (4 bits)	Rep count (12 bits)	RsvdZ (5 bits)	Variable header size (9 bits)	Fast (1 bit)	Call Code (16 bits)

FIGURE 9-16 The hypercall input value (from the hypervisor TLFS).

There are two classes of hypercalls: simple and rep (which stands for “repeat”). A *simple* hypercall performs a single operation and has a fixed-size set of input and output parameters. A *rep* hypercall acts like a series of simple hypercalls. When a caller initially invokes a rep hypercall, it specifies a rep count that indicates the number of elements in the input or output parameter list. Callers also specify a rep start index that indicates the next input or output element that should be consumed.

All hypercalls return another 64-bit value called *hypercall result value* (see Figure 9-17). Generally, the result value describes the operation's outcome, and, for rep hypercalls, the total number of completed repetition.

63:40	43:32	31:16	15:0
Rsvd (20 bits)	Rep complete (12 bits)	Rsvd (16 bits)	Result (16 bits)

FIGURE 9-17 The hypercall result value (from the hypervisor TLFS).

Hypercalls could take some time to be completed. Keeping a physical CPU that doesn't receive interrupts can be dangerous for the host OS. For example, Windows has a mechanism that detects whether a CPU has not received its clock tick interrupt for a period of time longer than 16 milliseconds. If this condition is detected, the system is suddenly stopped with a BSOD. The hypervisor therefore relies on a *hypercall continuation* mechanism for some hypercalls, including all rep hypercall forms. If a hypercall isn't able to complete within the prescribed time limit (usually 50 microseconds), control is returned back to the caller (through an operation called VM_ENTRY), but the instruction pointer is not advanced past the instruction that invoked the hypercall. This allows pending interrupts to be handled and other virtual processors to be scheduled. When the original calling thread resumes execution, it will re-execute the hypercall instruction and make forward progress toward completing the operation.

A driver usually never emits a hypercall directly through the platform-dependent opcode. Instead, it uses services exposed by the Windows hypervisor interface driver, which is available in two different versions:

- **WinHvr.sys** Loaded at system startup if the OS is running in the root partition and exposes hypercalls available in both the root and child partition.
- **WinHv.sys** Loaded only when the OS is running in a child partition. It exposes hypercalls available in the child partition only.

Routines and data structures exported by the Windows hypervisor interface driver are extensively used by the virtualization stack, especially by the VID driver, which, as we have already introduced, covers a key role in the functionality of the entire Hyper-V platform.

Intercepts

The root partition should be able to create a virtual environment that allows an unmodified guest OS, which was written to execute on physical hardware, to run in a hypervisor's guest partition. Such legacy guests may attempt to access physical devices that do not exist in a hypervisor partition (for example, by accessing certain I/O ports or by writing to specific MSRs). For these cases, the hypervisor provides the *host intercepts* facility; when a VP of a guest VM executes certain instructions or generates certain exceptions, the authorized root partition can intercept the event and alter the effect of the intercepted instruction such that, to the child, it mirrors the expected behavior in physical hardware.

When an intercept event occurs in a child partition, its VP is suspended, and an *intercept message* is sent to the root partition by the Synthetic Interrupt Controller (SynIC; see the following section for more details) from the hypervisor. The message is received thanks to the hypervisor's Synthetic ISR (Interrupt Service Routine), which the NT kernel installs during phase 0 of its startup only in case the system is enlightened and running under the hypervisor (see Chapter 12 for more details). The hypervisor synthetic ISR (*KiHvInterrupt*), usually installed on vector 0x30, transfers its execution to an external callback, which the VID driver has registered when it started (through the exposed *HvRegisterInterruptCallback* NT kernel API).

The VID driver is an intercept driver, meaning that it is able to register host intercepts with the hypervisor and thus receives all the intercept events that occur on child partitions. After the partition is initialized, the WM Worker process registers intercepts for various components of the virtualization stack. (For example, the virtual motherboard registers I/O intercepts for each virtual COM ports of the VM.) It sends an IOCTL to the VID driver, which uses the *HvInstallIntercept* hypercall to install the intercept on the child partition. When the child partition raises an intercept, the hypervisor suspends the VP and injects a synthetic interrupt in the root partition, which is managed by the *KiHvInterrupt* ISR. The latter routine transfers the execution to the registered VID Intercept callback, which manages the event and restarts the VP by clearing the intercept suspend synthetic register of the suspended VP.

The hypervisor supports the interception of the following events in the child partition:

- Access to I/O ports (read or write)
- Access to VP's MSR (read or write)
- Execution of CPUID instruction
- Exceptions
- Accesses to general purposes registers
- Hypercalls

The synthetic interrupt controller (SynIC)

The hypervisor virtualizes interrupts and exceptions for both the root and guest partitions through the synthetic interrupt controller (SynIC), which is an extension of a virtualized local APIC (see the Intel or AMD software developer manual for more details about the APIC). The SynIC is responsible for dispatching virtual interrupts to virtual processors (VPs). Interrupts delivered to a partition fall into two categories: *external* and *synthetic* (also known as internal or simply virtual interrupts). External interrupts originate from other partitions or devices; synthetic interrupts are originated from the hypervisor itself and are targeted to a partition's VP.

When a VP in a partition is created, the hypervisor creates and initializes a SynIC for each supported VTL. It then starts the VTL 0's SynIC, which means that it enables the virtualization of a physical CPU's

APIC in the VMCS (or VMCB) hardware data structure. The hypervisor supports three kinds of APIC virtualization while dealing with *external* hardware interrupts:

- In standard configuration, the APIC is virtualized through the event injection hardware support. This means that every time a partition accesses the VP's local APIC registers, I/O ports, or MSRs (in the case of x2APIC), it produces a VMEXIT, causing hypervisor codes to dispatch the interrupt through the SynIC, which eventually "injects" an event to the correct guest VP by manipulating VMCS/VMCB opaque fields (after it goes through the logic similar to a physical APIC, which determines whether the interrupt can be delivered).
- The APIC emulation mode works similar to the standard configuration. Every physical interrupt sent by the hardware (usually through the IOAPIC) still causes a VMEXIT, but the hypervisor does not have to inject any event. Instead, it manipulates a *virtual-APIC page* used by the processor to virtualize certain access to the APIC registers. When the hypervisor wants to inject an event, it simply manipulates some virtual registers mapped in the virtual-APIC page. The event is delivered by the hardware when a VMENTRY happens. At the same time, if a guest VP manipulates certain parts of its local APIC, it does not produce any VMEXIT, but the modification will be stored in the virtual-APIC page.
- Posted interrupts allow certain kinds of external interrupts to be delivered directly in the guest partition without producing any VMEXIT. This allows direct access devices to be mapped directly in the child partition without incurring any performance penalties caused by the VMEXITS. The physical processor processes the virtual interrupts by directly recording them as pending on the virtual-APIC page. (For more details, consult the Intel or AMD software developer manual.)

When the hypervisor starts a processor, it usually initializes the synthetic interrupt controller module for the physical processor (represented by a *CPU_PLS* data structure). The SynIC module of the physical processor is an array of an interrupt's descriptors, which make the connection between a physical interrupt and a virtual interrupt. A hypervisor interrupt descriptor (IDT entry), as shown in Figure 9-18, contains the data needed for the SynIC to correctly dispatch the interrupt, in particular the entity the interrupt is delivered to (a partition, the hypervisor, a spurious interrupt), the target VP (root, a child, multiple VPs, or a synthetic interrupt), the interrupt vector, the target VTL, and some other interrupt characteristics.

Dispatch Type
Target VP & VTL
Virtual Vector
Interrupt Characteristics
Hypervisor Reserved

FIGURE 9-18 The hypervisor physical interrupt descriptor.

In default configurations, all the interrupts are delivered to the root partition in VTL 0 or to the hypervisor itself (in the second case, the interrupt entry is Hypervisor Reserved). External interrupts can be delivered to a guest partition only when a direct access device is mapped into a child partition; NVMe devices are a good example.

Every time the thread backing a VP is selected for being executed, the hypervisor checks whether one (or more) synthetic interrupt needs to be delivered. As discussed previously, synthetic interrupts aren't generated by any hardware; they're usually generated from the hypervisor itself (under certain conditions), and they are still managed by the SynIC, which is able to inject the virtual interrupt to the correct VP. Even though they're extensively used by the NT kernel (the enlightened clock timer is a good example), synthetic interrupts are fundamental for the Virtual Secure Mode (VSM). We discuss them in the section "The Secure Kernel" later in this chapter.

The root partition can send a customized virtual interrupt to a child by using the *HvAssertVirtualInterrupt* hypercall (documented in the TLFS).

Inter-partition communication

The synthetic interrupt controller also has the important role of providing inter-partition communication facilities to the virtual machines. The hypervisor provides two principal mechanisms for one partition to communicate with another: messages and events. In both cases, the notifications are sent to the target VP using synthetic interrupts. Messages and events are sent from a source partition to a target partition through a preallocated *connection*, which is associated with a destination *port*.

One of the most important components that uses the inter-partition communication services provided by the SynIC is VMBus. (VMBus architecture is discussed in the "Virtualization stack" section later in this chapter.) The VMBus root driver (*Vmbus.sys*) in the root allocates a port ID (ports are identified by a 32-bit ID) and creates a port in the child partition by emitting the *HvCreatePort* hypercall through the services provided by the WinHv driver.

A port is allocated in the hypervisor from the receiver's memory pool. When a port is created, the hypervisor allocates sixteen message buffers from the port memory. The message buffers are maintained in a queue associated with a SINT (synthetic interrupt source) in the virtual processor's SynIC. The hypervisor exposes sixteen interrupt sources, which can allow the VMBus root driver to manage a maximum of 16 message queues. A synthetic message has the fixed size of 256 bytes and can transfer only 240 bytes (16 bytes are used as header). The caller of the *HvCreatePort* hypercall specifies which virtual processor and SINT to target.

To correctly receive messages, the WinHv driver allocates a synthetic interrupt message page (SIMP), which is then shared with the hypervisor. When a message is enqueued for a target partition, the hypervisor copies the message from its internal queue to the SIMP slot corresponding to the correct SINT. The VMBus root driver then creates a *connection*, which associates the port opened in the child VM to the parent, through the *HvConnectPort* hypercall. After the child has enabled the reception of synthetic interrupts in the correct SINT slot, the communication can start; the sender can post a message to the client by specifying a target Port ID and emitting the *HvPostMessage* hypercall. The hypervisor injects a synthetic interrupt to the target VP, which can read from the message page (SIMP) the content of the message.

The hypervisor supports ports and connections of three types:

- **Message ports** Transmit 240-byte *messages* from and to a partition. A message port is associated with a single SINT in the parent and child partition. Messages will be delivered in order through a single port message queue. This characteristic makes messages ideal for VMBus channel setup and teardown (further details are provided in the “Virtualization stack” section later in this chapter).
- **Event ports** Receive simple interrupts associated with a set of flags, set by the hypervisor when the opposite endpoint makes a *HvSignalEvent* hypercall. This kind of port is normally used as a synchronization mechanism. VMBus, for example, uses an event port to notify that a message has been posted on the ring buffer described by a particular channel. When the event interrupt is delivered to the target partition, the receiver knows exactly to which channel the interrupt is targeted thanks to the flag associated with the event.
- **Monitor ports** An optimization to the Event port. Causing a VMEXIT and a VM context switch for every single *HvSignalEvent* hypercall is an expensive operation. Monitor ports are set up by allocating a shared page (between the hypervisor and the partition) that contains a data structure indicating which event port is associated with a particular monitored notification flag (a bit in the page). In that way, when the source partition wants to send a synchronization interrupt, it can just set the corresponding flag in the shared page. Sooner or later the hypervisor will notice the bit set in the shared page and will trigger an interrupt to the event port.

The Windows hypervisor platform API and EXO partitions

Windows increasingly uses Hyper-V’s hypervisor for providing functionality not only related to running traditional VMs. In particular, as we will discuss in the second part of this chapter, VSM, an important security component of modern Windows versions, leverages the hypervisor to enforce a higher level of isolation for features that provide critical system services or handle secrets such as passwords. Enabling these features requires that the hypervisor is running by default on a machine.

External virtualization products, like VMware, Qemu, VirtualBox, Android Emulator, and many others use the virtualization extensions provided by the hardware to build their own hypervisors, which is needed for allowing them to correctly run. This is clearly not compatible with Hyper-V, which launches its hypervisor before the Windows kernel starts up in the root partition (the Windows hypervisor is a native, or bare-metal hypervisor).

As for Hyper-V, external virtualization solutions are also composed of a hypervisor, which provides generic low-level abstractions for the processor’s execution and memory management of the VM, and a virtualization stack, which refers to the components of the virtualization solution that provide the emulated environment for the VM (like its motherboard, firmware, storage controllers, devices, and so on).

The Windows Hypervisor Platform API, which is documented at <https://docs.microsoft.com/en-us/virtualization/api/>, has the main goal to enable running third-party virtualization solutions on the Windows hypervisor. Specifically, a third-party virtualization product should be able to create, delete, start, and stop VMs with characteristics (firmware, emulated devices, storage controllers) defined by its

own virtualization stack. The third-party virtualization stack, with its management interfaces, continues to run on Windows in the root partition, which allows for an unchanged use of its VMs by their client.

As shown in Figure 9-19, all the Windows hypervisor platform's APIs run in user mode and are implemented on the top of the VID and WinHvr driver in two libraries: WinHvPlatform.dll and WinHvEmulation.dll (the latter implements the instruction emulator for MMIO).

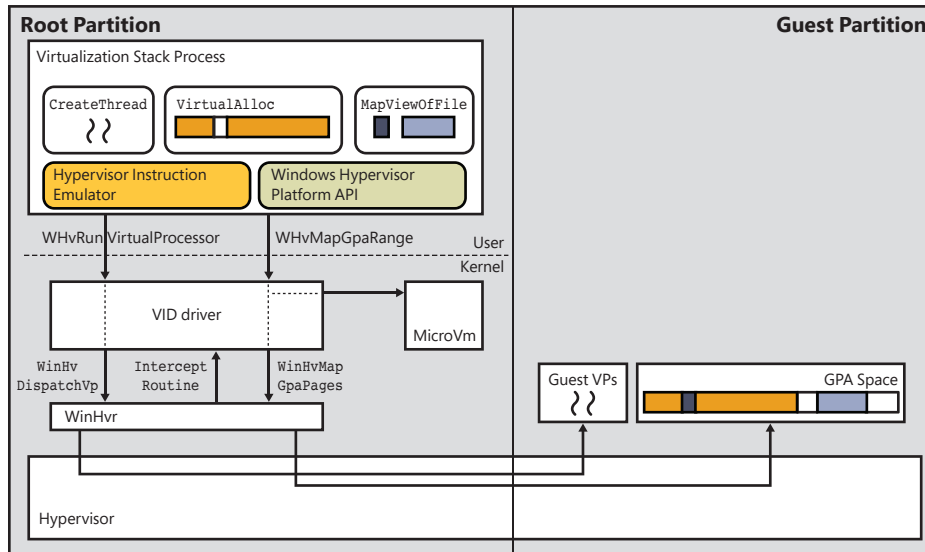

FIGURE 9-19 The Windows hypervisor platform API architecture.

A user mode application that wants to create a VM and its relative virtual processors usually should do the following:

1. Create the partition in the VID library (Vid.dll) with the *WHvCreatePartition* API.
2. Configure various internal partition's properties—like its virtual processor count, the APIC emulation mode, the kind of requested VMEXITs, and so on—using the *WHvSetPartitionProperty* API.
3. Create the partition in the VID driver and the hypervisor using the *WHvSetupPartition* API. (This kind of partition in the hypervisor is called an EXO partition, as described shortly.) The API also creates the partition's virtual processors, which are created in a suspended state.
4. Create the corresponding virtual processor(s) in the VID library through the *WHvCreateVirtualProcessor* API. This step is important because the API sets up and maps a message buffer into the user mode application, which is used for asynchronous communication with the hypervisor and the thread running the virtual CPUs.
5. Allocate the address space of the partition by reserving a big range of virtual memory with the classic *VirtualAlloc* function (read more details in Chapter 5 of Part 1) and map it in the hypervisor through the *WHvMapGpaRange* API. A fine-grained protection of the guest physical memory can be specified when allocating guest physical memory in the guest virtual address space by committing different ranges of the reserved virtual memory.

6. Create the page-tables and copy the initial firmware code in the committed memory.
7. Set the initial VP's registers content using the *WHvSetVirtualProcessorRegisters* API.
8. Run the virtual processor by calling the *WHvRunVirtualProcessor* blocking API. The function returns only when the guest code executes an operation that requires handling in the virtualization stack (a VMEXIT in the hypervisor has been explicitly required to be managed by the third-party virtualization stack) or because of an external request (like the destroying of the virtual processor, for example).

The Windows hypervisor platform APIs are usually able to call services in the hypervisor by sending different IOCTLs to the `\Device\VIDExo` device object, which is created by the VID driver at initialization time, only if the `HKLM\System\CurrentControlSet\Services\VID\Parameters\ExoDeviceEnabled` registry value is set to 1. Otherwise, the system does not enable any support for the hypervisor APIs.

Some performance-sensitive hypervisor platform APIs (a good example is provided by *WHvRunVirtualProcessor*) can instead call directly into the hypervisor from user mode thanks to the *Doorbell page*, which is a special invalid guest physical page, that, when accessed, always causes a VMEXIT. The Windows hypervisor platform API obtains the address of the doorbell page from the VID driver. It writes to the doorbell page every time it emits a hypercall from user mode. The fault is identified and treated differently by the hypervisor thanks to the doorbell page's physical address, which is marked as "special" in the SLAT page table. The hypervisor reads the hypercall's code and parameters from the VP's registers as per normal hypercalls, and ultimately transfers the execution to the hypercall's handler routine. When the latter finishes its execution, the hypervisor finally performs a VMENTRY, landing on the instruction following the faulty one. This saves a lot of clock cycles to the thread backing the guest VP, which no longer has a need to enter the kernel for emitting a hypercall. Furthermore, the VMCALL and similar opcodes always require kernel privileges to be executed.

The virtual processors of the new third-party VM are dispatched using the root scheduler. In case the root scheduler is disabled, any function of the hypervisor platform API can't run. The created partition in the hypervisor is an EXO partition. EXO partitions are minimal partitions that don't include any synthetic functionality and have certain characteristics ideal for creating third-party VMs:

- They are always VA-backed types. (More details about VA-backed or micro VMs are provided later in the "Virtualization stack" section.) The partition's memory-hosting process is the user mode application, which created the VM, and not a new instance of the VMMEM process.
- They do not have any partition's privilege or support any VTL (virtual trust level) other than 0. All of a classical partition's privileges refer to synthetic functionality, which is usually exposed by the hypervisor to the Hyper-V virtualization stack. EXO partitions are used for third-party virtualization stacks. They do not need the functionality brought by any of the classical partition's privilege.
- They manually manage timing. The hypervisor does not provide any virtual clock interrupt source for EXO partition. The third-party virtualization stack must take over the responsibility of providing this. This means that every attempt to read the virtual processor's time-stamp counter will cause a VMEXIT in the hypervisor, which will route the intercept to the user mode thread that runs the VP.



Note EXO partitions include other minor differences compared to classical hypervisor partitions. For the sake of the discussion, however, those minor differences are irrelevant, so they are not mentioned in this book.

Nested virtualization

Large servers and cloud providers sometimes need to be able to run containers or additional virtual machines inside a guest partition. Figure 9-20 describes this scenario: The hypervisor that runs on the top of the bare-metal hardware, identified as the L0 hypervisor (L0 stands for Level 0), uses the virtualization extensions provided by the hardware to create a guest VM. Furthermore, the L0 hypervisor emulates the processor's virtualization extensions and exposes them to the guest VM (the ability to expose virtualization extensions is called *nested virtualization*). The guest VM can decide to run another instance of the hypervisor (which, in this case, is identified as L1 hypervisor, where L1 stands for Level 1), by using the emulated virtualization extensions exposed by the L0 hypervisor. The L1 hypervisor creates the nested root partition and starts the L2 root operating system in it. In the same way, the L2 root can orchestrate with the L1 hypervisor to launch a nested guest VM. The final guest VM in this configuration takes the name of L2 guest.

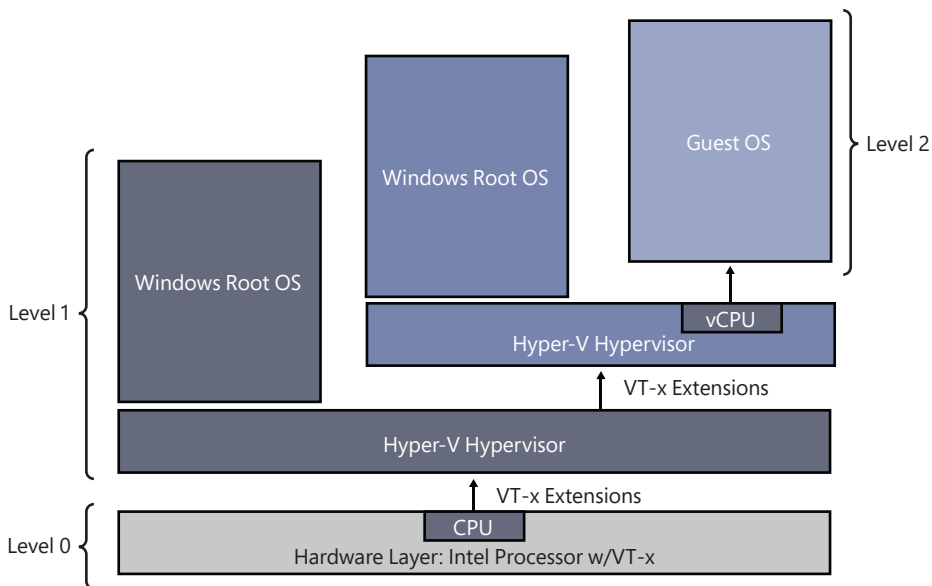

FIGURE 9-20 Nested virtualization scheme.

Nested virtualization is a software construction: the hypervisor must be able to emulate and manage virtualization extensions. Each virtualization instruction, while executed by the L1 guest VM, causes a VMEXIT to the L0 hypervisor, which, through its emulator, can reconstruct the instruction and perform the needed work to emulate it. At the time of this writing, only Intel and AMD hardware is supported. The nested virtualization capability should be explicitly enabled for the L1 virtual machine;

otherwise, the L0 hypervisor injects a general protection exception in the VM in case a virtualization instruction is executed by the guest operating system.

On Intel hardware, Hyper-V allows nested virtualization to work thanks to two main concepts:

- Emulation of the VT-x virtualization extensions
- Nested address translation

As discussed previously in this section, for Intel hardware, the basic data structure that describes a virtual machine is the virtual machine control structure (VMCS). Other than the standard physical VMCS representing the L1 VM, when the L0 hypervisor creates a VP belonging to a partition that supports nested virtualization, it allocates some nested VMCS data structures (not to be confused with a virtual VMCS, which is a different concept). The nested VMCS is a software descriptor that contains all the information needed by the L0 hypervisor to start and run a nested VP for a L2 partition. As briefly introduced in the “Hypervisor startup” section, when the L1 hypervisor boots, it detects whether it’s running in a virtualized environment and, if so, enables various nested enlightenments, like the enlightened VMCS or the direct virtual flush (discussed later in this section).

As shown in Figure 9-21, for each nested VMCS, the L0 hypervisor also allocates a Virtual VMCS and a hardware physical VMCS, two similar data structures representing a VP running the L2 virtual machine. The virtual VMCS is important because it has the key role in maintaining the nested virtualized data. The physical VMCS instead is loaded by the L0 hypervisor when the L2 virtual machine is started; this happens when the L0 hypervisor intercepts a VMLAUNCH instruction executed by the L1 hypervisor.

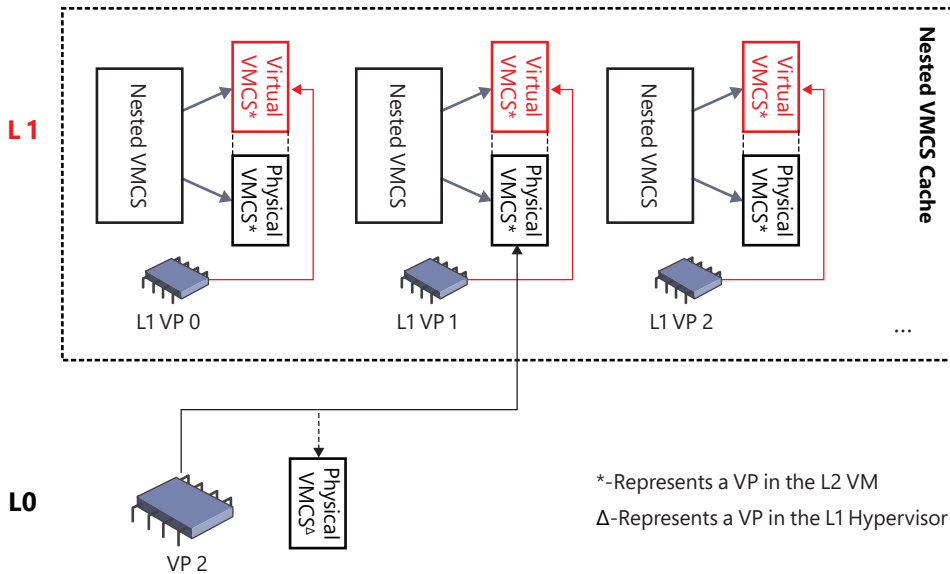

FIGURE 9-21 A L0 hypervisor running a L2 VM by virtual processor 2.

In the sample picture, the L0 hypervisor has scheduled the VP 2 for running a L2 VM managed by the L1 hypervisor (through the nested virtual processor 1). The L1 hypervisor can operate only on virtualization data replicated in the virtual VMCS.

Emulation of the VT-x virtualization extensions

On Intel hardware, the L0 hypervisor supports both enlightened and nonenlightened L1 hypervisors. The only official supported configuration is Hyper-V running on the top of Hyper-V, though.

In a nonenlightened hypervisor, all the VT-x instructions executed in the L1 guest causes a VMEXIT. After the L1 hypervisor has allocated the guest physical VMCS for describing the new L2 VM, it usually marks it as active (through the VMPTRLD instruction on Intel hardware). The L0 hypervisor intercepts the operation and associates an allocated nested VMCS with the guest physical VMCS specified by the L1 hypervisor. Furthermore, it fills the initial values for the virtual VMCS and sets the nested VMCS as active for the current VP. (It does not switch the physical VMCS though; the execution context should remain the L1 hypervisor.) Each subsequent read or write to the physical VMCS performed by the L1 hypervisor is always intercepted by the L0 hypervisor and redirected to the virtual VMCS (refer to Figure 9-21).

When the L1 hypervisor launches the VM (performing an operation called VMENTRY), it executes a specific hardware instruction (VMLAUNCH on Intel hardware), which is intercepted by the L0 hypervisor. For nonenlightened scenarios, the L0 hypervisor copies all the guest fields of the virtual VMCS to another physical VMCS representing the L2 VM, writes the host fields by pointing them to L0 hypervisor's entry points, and sets it as active (by using the hardware VMPTRLD instruction on Intel platforms). In case the L1 hypervisor uses the second level address translation (EPT for Intel hardware), the L0 hypervisor then shadows the currently active L1 extended page tables (see the following section for more details). Finally, it performs the actual VMENTRY by executing the specific hardware instruction. As a result, the hardware executes the L2 VM's code.

While executing the L2 VM, each operation that causes a VMEXIT switches the execution context back to the L0 hypervisor (instead of the L1). As a response, the L0 hypervisor performs another VMENTRY on the original physical VMCS representing the L1 hypervisor context, injecting a synthetic VMEXIT event. The L1 hypervisor restarts the execution and handles the intercepted event as for regular non-nested VMEXITS. When the L1 completes the internal handling of the synthetic VMEXIT event, it executes a VMRESUME operation, which will be intercepted again by the L0 hypervisor and managed in a similar way of the initial VMENTRY operation described earlier.

Producing a VMEXIT each time the L1 hypervisor executes a virtualization instruction is an expensive operation, which could definitively contribute in the general slowdown of the L2 VM. For overcoming this problem, the Hyper-V hypervisor supports the enlightened VMCS, an optimization that, when enabled, allows the L1 hypervisor to load, read, and write virtualization data from a memory page shared between the L1 and L0 hypervisor (instead of a physical VMCS). The shared page is called enlightened VMCS. When the L1 hypervisor manipulates the virtualization data belonging to a L2 VM, instead of using hardware instructions, which cause a VMEXIT into the L0 hypervisor, it directly reads and writes from the enlightened VMCS. This significantly improves the performance of the L2 VM.

In enlightened scenarios, the L0 hypervisor intercepts only VMENTRY and VMEXIT operations (and some others that are not relevant for this discussion). The L0 hypervisor manages VMENTRY in a similar way to the nonenlightened scenario, but, before doing anything described previously, it copies the virtualization data located in the shared enlightened VMCS memory page to the virtual VMCS representing the L2 VM.



Note It is worth mentioning that for nonenlightened scenarios, the L0 hypervisor supports another technique for preventing VMEXITs while managing nested virtualization data, called shadow VMCS. Shadow VMCS is a hardware optimization very similar to the enlightened VMCS.

Nested address translation

As previously discussed in the “Partitions’ physical address space” section, the hypervisor uses the SLAT for providing an isolated guest physical address space to a VM and to translate GPAs to real SPAs. Nested virtual machines would require another hardware layer of translation on top of the two already existing. For supporting nested virtualization, the new layer should have been able to translate L2 GPAs to L1 GPAs. Due to the increased complexity in the electronics needed to build a processor’s MMU that manages three layers of translations, the Hyper-V hypervisor adopted another strategy for providing the additional layer of address translation, called shadow nested page tables. Shadow nested page tables use a technique similar to the shadow paging (see the previous section) for directly translating L2 GPAs to SPAs.

When a partition that supports nested virtualization is created, the L0 hypervisor allocates and initializes a nested page table shadowing domain. The data structure is used for storing a list of shadow nested page tables associated with the different L2 VMs created in the partition. Furthermore, it stores the partition’s active domain generation number (discussed later in this section) and nested memory statistics.

When the L0 hypervisor performs the initial VMENTRY for starting a L2 VM, it allocates the shadow nested page table associated with the VM and initializes it with empty values (the resulting physical address space is empty). When the L2 VM begins code execution, it immediately produces a VMEXIT to the L0 hypervisor due to a nested page fault (EPT violation in Intel hardware). The L0 hypervisor, instead of injecting the fault in the L1, walks the guest’s nested page tables built by the L1 hypervisor. If it finds a valid entry for the specified L2 GPA, it reads the corresponding L1 GPA, translates it to an SPA, and creates the needed shadow nested page table hierarchy to map it in the L2 VM. It then fills the leaf table entry with the valid SPA (the hypervisor uses large pages for mapping shadow nested pages) and resumes the execution directly to the L2 VM by setting the nested VMCS that describes it as active.

For the nested address translation to work correctly, the L0 hypervisor should be aware of any modifications that happen to the L1 nested page tables; otherwise, the L2 VM could run with stale entries. This implementation is platform specific; usually hypervisors protect the L2 nested page table for read-only access. In that way they can be informed when the L1 hypervisor modifies it. The Hyper-V hypervisor adopts another smart strategy, though. It guarantees that the shadow nested page table describing the L2 VM is always updated because of the following two premises:

- When the L1 hypervisor adds new entries in the L2 nested page table, it does not perform any other action for the nested VM (no intercepts are generated in the L0 hypervisor). An entry in the shadow nested page table is added only when a nested page fault causes a VMEXIT in the L0 hypervisor (the scenario described previously).
- As for non-nested VM, when an entry in the nested page table is modified or deleted, the hypervisor should always emit a TLB flush for correctly invalidating the hardware TLB. In case

of nested virtualization, when the L1 hypervisor emits a TLB flush, the L0 intercepts the request and completely invalidates the shadow nested page table. The L0 hypervisor maintains a virtual TLB concept thanks to the generation IDs stored in both the shadow VMCS and the nested page table shadowing domain. (Describing the virtual TLB architecture is outside the scope of the book.)

Completely invalidating the shadow nested page table for a single address changed seems to be redundant, but it's dictated by the hardware support. (The INVEPT instruction on Intel hardware does not allow specifying which single GPA to remove from the TLB.) In classical VMs, this is not a problem because modifications on the physical address space don't happen very often. When a classical VM is started, all its memory is already allocated. (The "Virtualization stack" section will provide more details.) This is not true for VA-backed VMs and VSM, though.

For improving performance in nonclassical nested VMs and VSM scenarios (see the next section for details), the hypervisor supports the "direct virtual flush" enlightenment, which provides to the L1 hypervisor two hypercalls to directly invalidate the TLB. In particular, the *HvFlushGuestPhysicalAddress List* hypercall (documented in the TLFS) allows the L1 hypervisor to invalidate a single entry in the shadow nested page table, removing the performance penalties associated with the flushing of the entire shadow nested page table and the multiple VMEXIT needed to reconstruct it.

EXPERIMENT: Enabling nested virtualization on Hyper-V

As explained in this section, for running a virtual machine into a L1 Hyper-V VM, you should first enable the nested virtualization feature in the host system. For this experiment, you need a workstation with an Intel or AMD CPU and Windows 10 or Windows Server 2019 installed (Anniversary Update RS1 minimum version). You should create a Type-2 VM using the Hyper-V Manager or Windows PowerShell with at least 4 GB of memory. In the experiment, you're creating a nested L2 VM into the created VM, so enough memory needs to be assigned.

After the first startup of the VM and the initial configuration, you should shut down the VM and open an administrative PowerShell window (type **Windows PowerShell** in the Cortana search box. Then right-click the **PowerShell icon** and select **Run As Administrator**). You should then type the following command, where the term "*<VmName>*" must be replaced by your virtual machine name:

```
Set-VMProcessor -VMName "<VmName>" -ExposeVirtualizationExtension $true
```

To properly verify that the nested virtualization feature is correctly enabled, the command

```
$(Get-VMProcessor -VMName "<VmName>").ExposeVirtualizationExtensions
```

should return True.

After the nested virtualization feature has been enabled, you can restart your VM. Before being able to run the L1 hypervisor in the virtual machine, you should add the necessary component through the Control panel. In the VM, search **Control Panel** in the Cortana box, open it, click **Programs**, and the select **Turn Windows Features On Or Off**. You should check the entire Hyper-V tree, as shown in the next figure.

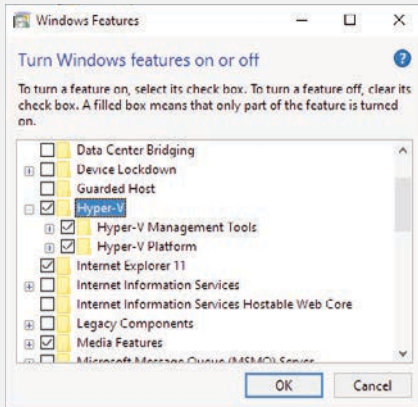

Click **OK**. After the procedure finishes, click **Restart** to reboot the virtual machine (this step is needed). After the VM restarts, you can verify the presence of the L1 hypervisor through the System Information application (type **msinfo32** in the Cortana search box. Refer to the “Detecting VBS and its provided services” experiment later in this chapter for further details). If the hypervisor has not been started for some reason, you can force it to start by opening an administrative command prompt in the VM (type **cmd** in the Cortana search box and select **Run As Administrator**) and insert the following command:

```
bcdedit /set {current} hypervisorlaunchtype Auto
```

At this stage, you can use the Hyper-V Manager or Windows PowerShell to create a L2 guest VM directly in your virtual machine. The result can be something similar to the following figure.

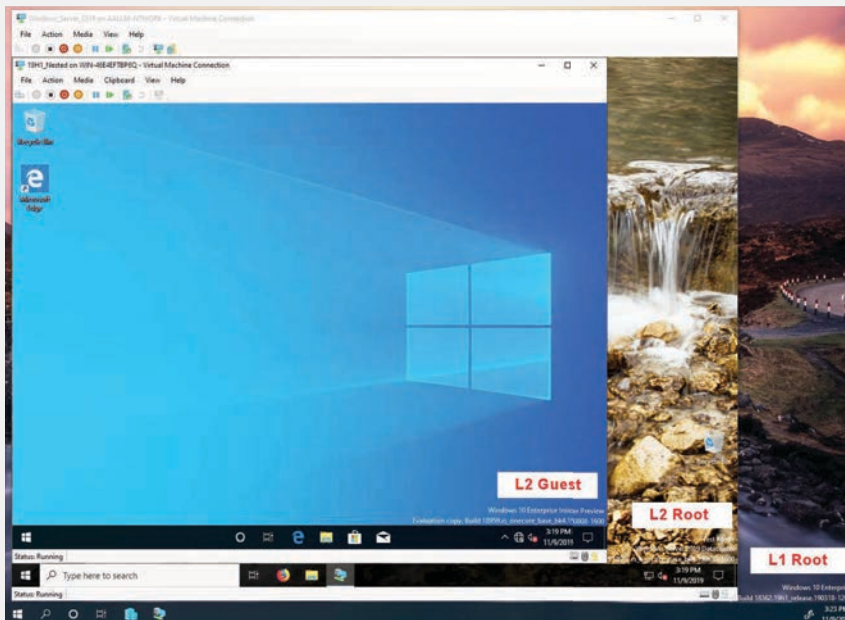

From the L2 root partition, you can also enable the L1 hypervisor debugger, in a similar way as explained in the “Connecting the hypervisor debugger” experiment previously in this chapter. The only limitation at the time of this writing is that you can’t use the network debugging in nested configurations; the only supported configuration for debugging the L1 hypervisor is through serial port. This means that in the host system, you should enable two virtual serial ports in the L1 VM (one for the hypervisor and the other one for the L2 root partition) and attach them to named pipes. For type-2 virtual machines, you should use the following PowerShell commands to set the two serial ports in the L1 VM (as with the previous commands, you should replace the term “<VMName>” with the name of your virtual machine):

```
Set-VMComPort -VMName "<VMName>" -Number 1 -Path \\.\pipe\HV_dbg
Set-VMComPort -VMName "<VMName>" -Number 2 -Path \\.\pipe\NT_dbg
```

After that, you should configure the hypervisor debugger to be attached to the COM1 serial port, while the NT kernel debugger should be attached to the COM2 (see the previous experiment for more details).

The Windows hypervisor on ARM64

Unlike the x86 and AMD64 architectures, where the hardware virtualization support was added long after their original design, the ARM64 architecture has been designed with hardware virtualization support. In particular, as shown in Figure 9-22, the ARM64 execution environment has been split in three different security domains (called Exception Levels). The EL determines the level of privilege; the higher the EL, the more privilege the executing code has. Although all the user mode applications run in EL0, the NT kernel (and kernel mode drivers) usually runs in EL1. In general, a piece of software runs only in a single exception level. EL2 is the privilege level designed for running the hypervisor (which, in ARM64 is also called “Virtual machine manager”) and is an exception to this rule. The hypervisor provides virtualization services and can run in Nonsecure World both in EL2 and EL1. (EL2 does not exist in the Secure World. ARM TrustZone will be discussed later in this section.)

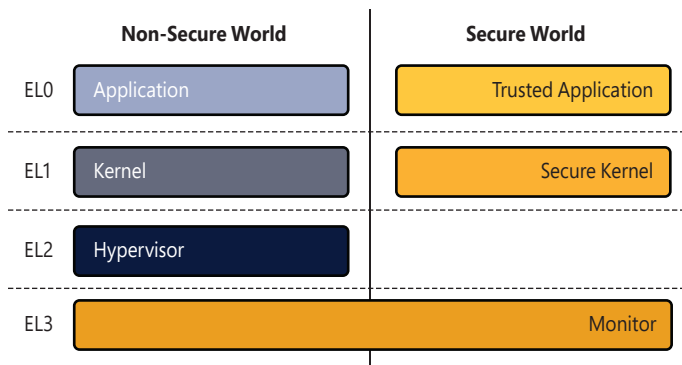

FIGURE 9-22 The ARM64 execution environment.

Unlike from the AMD64 architecture, where the CPU enters the root mode (the execution domain in which the hypervisor runs) only from the kernel context and under certain assumptions, when a standard ARM64 device boots, the UEFI firmware and the boot manager begin their execution in EL2. On those devices, the hypervisor loader (or Secure Launcher, depending on the boot flow) is able to start the hypervisor directly and, at later time, drop the exception level to EL1 (by emitting an exception return instruction, also known as ERET).

On the top of the exception levels, TrustZone technology enables the system to be partitioned between two execution security states: secure and non-secure. Secure software can generally access both secure and non-secure memory and resources, whereas normal software can only access non-secure memory and resources. The non-secure state is also referred to as the Normal World. This enables an OS to run in parallel with a trusted OS on the same hardware and provides protection against certain software attacks and hardware attacks. The secure state, also referred as Secure World, usually runs secure devices (their firmware and IOMMU ranges) and, in general, everything that requires the processor to be in the secure state.

To correctly communicate with the Secure World, the non-secure OS emits *secure method calls* (SMC), which provide a mechanism similar to standard OS syscalls. SMC are managed by the TrustZone. TrustZone usually provides separation between the Normal and the Secure Worlds through a thin memory protection layer, which is provided by well-defined hardware memory protection units (Qualcomm calls these XPUs). The XPUs are configured by the firmware to allow only specific execution environments to access specific memory locations. (Secure World memory can't be accessed by Normal World software.)

In ARM64 server machines, Windows is able to directly start the hypervisor. Client machines often do not have XPUs, even though TrustZone is enabled. (The majority of the ARM64 client devices in which Windows can run are provided by Qualcomm.) In those client devices, the separation between the Secure and Normal Worlds is provided by a proprietary hypervisor, named QHEE, which provides memory isolation using stage-2 memory translation (this layer is the same as the SLAT layer used by the Windows hypervisor). QHEE intercepts each SMC emitted by the running OS: it can forward the SMC directly to TrustZone (after having verified the necessary access rights) or do some work on its behalf. In these devices, TrustZone also has the important responsibility to load and verify the authenticity of the machine firmware and coordinates with QHEE for correctly executing the Secure Launch boot method.

Although in Windows the Secure World is generally not used (a distinction between Secure/Non secure world is already provided by the hypervisor through VTL levels), the Hyper-V hypervisor still runs in EL2. This is not compatible with the QHEE hypervisor, which runs in EL2, too. To solve the problem correctly, Windows adopts a particular boot strategy; the Secure launch process is orchestrated with the aid of QHEE. When the Secure Launch terminates, the QHEE hypervisor unloads and gives up execution to the Windows hypervisor, which has been loaded as part of the Secure Launch. In later boot stages, after the Secure Kernel has been launched and the SMSS is creating the first user mode session, a new special trustlet is created (Qualcomm named it as "QcExt"). The trustlet acts as the original ARM64 hypervisor; it intercepts all the SMC requests, verifies the integrity of them, provides the needed memory isolations (through the services exposed by the Secure Kernel) and is able to send and receive commands from the Secure Monitor in EL3.

The SMC interception architecture is implemented in both the NT kernel and the ARM64 trustlet and is outside the scope of this book. The introduction of the new trustlet has allowed the majority of the client ARM64 machines to boot with Secure Launch and Virtual Secure Mode enabled by default. (VSM is discussed later in this chapter.)

The virtualization stack

Although the hypervisor provides isolation and the low-level services that manage the virtualization hardware, all the high-level implementation of virtual machines is provided by the virtualization stack. The virtualization stack manages the states of the VMs, provides memory to them, and virtualizes the hardware by providing a virtual motherboard, the system firmware, and multiple kind of virtual devices (emulated, synthetic, and direct access). The virtualization stack also includes VMBus, an important component that provides a high-speed communication channel between a guest VM and the root partition and can be accessed through the kernel mode client library (KMCL) abstraction layer.

In this section, we discuss some important services provided by the virtualization stack and analyze its components. Figure 9-23 shows the main components of the virtualization stack.

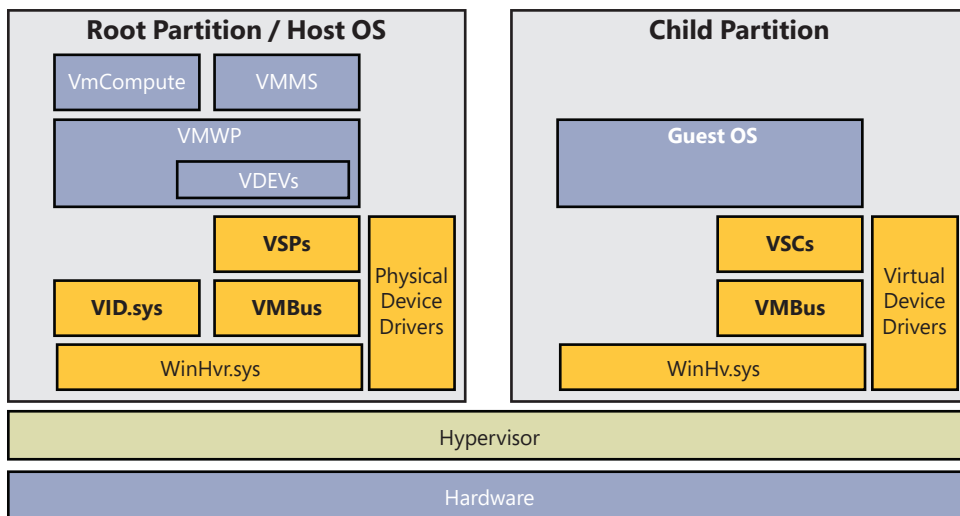

FIGURE 9-23 Components of the virtualization stack.

Virtual machine manager service and worker processes

The virtual machine manager service (Vmms.exe) is responsible for providing the Windows Management Instrumentation (WMI) interface to the root partition, which allows managing the child partitions through a Microsoft Management Console (MMC) plug-in or through PowerShell. The VMMS service manages the requests received through the WMI interface on behalf of a VM (identified internally through a GUID), like start, power off, shutdown, pause, resume, reboot, and so on. It controls settings such as which devices are visible to child partitions and how the memory and

processor allocation for each partition is defined. The VMMS manages the addition and removal of devices. When a virtual machine is started, the VMM Service also has the crucial role of creating a corresponding Virtual Machine Worker Process (VMWP.exe). The VMMS manages the VM snapshots by redirecting the snapshot requests to the VMWP process in case the VM is running or by taking the snapshot itself in the opposite case.

The VMWP performs various virtualization work that a typical monolithic hypervisor would perform (similar to the work of a software-based virtualization solution). This means managing the state machine for a given child partition (to allow support for features such as snapshots and state transitions), responding to various notifications coming in from the hypervisor, performing the emulation of certain devices exposed to child partitions (called emulated devices), and collaborating with the VM service and configuration component. The Worker process has the important role to start the virtual motherboard and to maintain the state of each virtual device that belongs to the VM. It also includes components responsible for remote management of the virtualization stack, as well as an RDP component that allows using the remote desktop client to connect to any child partition and remotely view its user interface and interact with it. The VM Worker process exposes the COM objects that provide the interface used by the Vmms (and the VmCompute service) to communicate with the VMWP instance that represents a particular virtual machine.

The VM host compute service (implemented in the Vmcompute.exe and Vmcompute.dll binaries) is another important component that hosts most of the computation-intensive operations that are not implemented in the VM Manager Service. Operation like the analysis of a VM's memory report (for dynamic memory), management of VHD and VHDX files, and creation of the base layers for containers are implemented in the VM host compute service. The Worker Process and Vmms can communicate with the host compute service thanks the COM objects that it exposes.

The Virtual Machine Manager Service, the Worker Process, and the VM compute service are able to open and parse multiple configuration files that expose a list of all the virtual machines created in the system, and the configuration of each of them. In particular:

- The configuration repository stores the list of virtual machines installed in the system, their names, configuration file and GUID in the data.vmcx file located in C:\ProgramData\Microsoft\Windows Hyper-V.
- The VM Data Store repository (part of the VM host compute service) is able to open, read, and write the configuration file (usually with ".vmcx" extension) of a VM, which contains the list of virtual devices and the virtual hardware's configuration.

The VM data store repository is also used to read and write the VM Save State file. The VM State file is generated while pausing a VM and contains the save state of the running VM that can be restored at a later time (state of the partition, content of the VM's memory, state of each virtual device). The configuration files are formatted using an XML representation of key/value pairs. The plain XML data is stored compressed using a proprietary binary format, which adds a write-journal logic to make it resilient against power failures. Documenting the binary format is outside the scope of this book.

The VID driver and the virtualization stack memory manager

The Virtual Infrastructure Driver (VID.sys) is probably one of the most important components of the virtualization stack. It provides partition, memory, and processor management services for the virtual machines running in the child partition, exposing them to the VM Worker process, which lives in the root. The VM Worker process and the VMMS services use the VID driver to communicate with the hypervisor, thanks to the interfaces implemented in the Windows hypervisor interface driver (WinHv.sys and WinHvr.sys), which the VID driver imports. These interfaces include all the code to support the hypervisor's hypercall management and allow the operating system (or generic kernel mode drivers) to access the hypervisor using standard Windows API calls instead of hypercalls.

The VID driver also includes the virtualization stack memory manager. In the previous section, we described the hypervisor memory manager, which manages the physical and virtual memory of the hypervisor itself. The guest physical memory of a VM is allocated and managed by the virtualization stack's memory manager. When a VM is started, the spawned VM Worker process (VMWP.exe) invokes the services of the memory manager (defined in the *IMemoryManager* COM interface) for constructing the guest VM's RAM. Allocating memory for a VM is a two-step process:

1. The VM Worker process obtains a report of the global system's memory state (by using services from the Memory Balancer in the VMMS process), and, based on the available system memory, determines the size of the physical memory blocks to request to the VID driver (through the *VID_RESERVE* IOCTL. Sizes of the block vary from 64 MB up to 4 GB). The blocks are allocated by the VID driver using MDL management functions (*MmAllocatePartitionNodePagesForMdlEx* in particular). For performance reasons, and to avoid memory fragmentation, the VID driver implements a best-effort algorithm to allocate huge and large physical pages (1 GB and 2 MB) before relying on standard small pages. After the memory blocks are allocated, their pages are deposited to an internal "reserve" bucket maintained by the VID driver. The bucket contains page lists ordered in an array based on their quality of service (QOS). The QOS is determined based on the page type (huge, large, and small) and the NUMA node they belong to. This process in the VID nomenclature is called "reserving physical memory" (not to be confused with the term "reserving virtual memory," a concept of the NT memory manager).
2. From the virtualization stack perspective, physical memory *commitment* is the process of emptying the reserved pages in the bucket and moving them in a VID memory block (*VSMM_MEMORY_BLOCK* data structure), which is created and owned by the VM Worker process using the VID driver's services. In the process of creating a memory block, the VID driver first deposits additional physical pages in the hypervisor (through the *Winhvr* driver and the *HvDepositMemory* hypercall). The additional pages are needed for creating the SLAT table page hierarchy of the VM. The VID driver then requests to the hypervisor to map the physical pages describing the entire guest partition's RAM. The hypervisor inserts valid entries in the SLAT table and sets their proper permissions. The guest physical address space of the partition is created. The GPA range is inserted in a list belonging to the VID partition. The VID memory block is owned by the VM Worker process. It's also used for tracking guest memory and in DAX file-backed memory blocks. (See Chapter 11, "Caching and file system support," for more details about DAX volumes and PMEM.) The VM Worker process can later use the memory block for multiple purposes—for example, to access some pages while managing emulated devices.

The birth of a Virtual Machine (VM)

The process of starting up a virtual machine is managed primarily by the VMMS and VMWP process. When a request to start a VM (internally identified by a GUID) is delivered to the VMMS service (through PowerShell or the Hyper-V Manager GUI application), the VMMS service begins the starting process by reading the VM's configuration from the data store repository, which includes the VM's GUID and the list of all the virtual devices (VDEVs) comprising its virtual hardware. It then verifies that the path containing the VHD (or VHDX) representing the VM's virtual hard disk has the correct access control list (ACL, more details provided later). In case the ACL is not correct, if specified by the VM configuration, the VMMS service (which runs under a SYSTEM account) rewrites a new one, which is compatible with the new VMWP process instance. The VMMS uses COM services to communicate with the Host Compute Service to spawn a new VMWP process instance.

The Host Compute Service gets the path of the VM Worker process by querying its COM registration data located in the Windows registry (*HKCU\CLSID\{f33463e0-7d59-11d9-9916-0008744f51f3}* key). It then creates the new process using a well-defined access token, which is built using the virtual machine SID as the owner. Indeed, the NT Authority of the Windows Security model defines a well-known subauthority value (83) to identify VMs (more information on system security components are available in Part 1, Chapter 7, "Security"). The Host Compute Service waits for the VMWP process to complete its initialization (in this way the exposed COM interfaces become ready). The execution returns to the VMMS service, which can finally request the starting of the VM to the VMWP process (through the exposed *IVirtualMachine* COM interface).

As shown in Figure 9-24, the VM Worker process performs a "cold start" state transition for the VM. In the VM Worker process, the entire VM is managed through services exposed by the "Virtual Motherboard." The Virtual Motherboard emulates an Intel i440BX motherboard on Generation 1 VMs, whereas on Generation 2, it emulates a proprietary motherboard. It manages and maintains the list of virtual devices and performs the state transitions for each of them. As covered in the next section, each virtual device is implemented as a COM object (exposing the *IVirtualDevice* interface) in a DLL. The Virtual Motherboard enumerates each virtual device from the VM's configuration and loads the relative COM object representing the device.

The VM Worker process begins the startup procedure by reserving the resources needed by each virtual device. It then constructs the VM guest physical address space (virtual RAM) by allocating physical memory from the root partition through the VID driver. At this stage, it can power up the virtual motherboard, which will cycle between each VDEV and power it up. The power-up procedure is different for each device: for example, synthetic devices usually communicate with their own Virtualization Service Provider (VSP) for the initial setup.

One virtual device that deserves a deeper discussion is the virtual BIOS (implemented in the *Vmchipset.dll* library). Its power-up method allows the VM to include the initial firmware executed when the bootstrap VP is started. The BIOS VDEV extracts the correct firmware for the VM (legacy BIOS in the case of Generation 1 VMs; UEFI otherwise) from the resource section of its own backing library, builds the volatile configuration part of the firmware (like the ACPI and the SRAT table), and injects it in the proper guest physical memory by using services provided by the VID driver. The VID driver is indeed able to map memory ranges described by the VID memory block in user mode memory, accessible by the VM Worker process (this procedure is internally called "memory aperture creation").

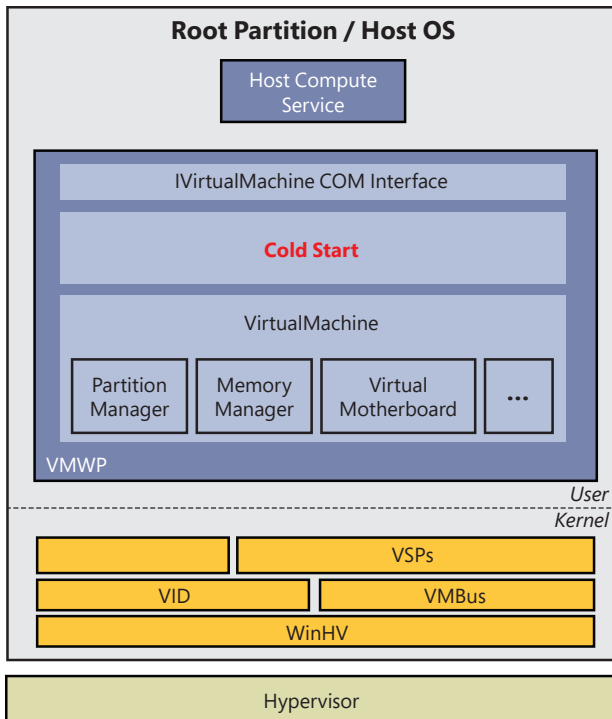

FIGURE 9-24 The VM Worker process and its interface for performing a “cold start” of a VM.

After all the virtual devices have been successfully powered up, the VM Worker process can start the bootstrap virtual processor of the VM by sending a proper IOCTL to the VID driver, which will start the VP and its message pump (used for exchanging messages between the VID driver and the VM Worker process).

EXPERIMENT: Understanding the security of the VM Worker process and the virtual hard disk files

In the previous section, we discussed how the VM Worker process is launched by the Host Compute service (`Vmcompute.exe`) when a request to start a VM is delivered to the VMMS process (through WMI). Before communicating with the Host Compute Service, the VMMS generates a security token for the new Worker process instance.

Three new entities have been added to the Windows security model to properly support virtual machines (the Windows Security model has been extensively discussed in Chapter 7 of Part 1):

- A “virtual machines” security group, identified with the S-1-5-83-0 security identifier.
- A virtual machine security identifier (SID), based on the VM’s unique identifier (GUID). The VM SID becomes the owner of the security token generated for the VM Worker process.
- A VM Worker process security capability used to give applications running in AppContainers access to Hyper-V services required by the VM Worker process.

In this experiment, you will create a new virtual machine through the Hyper-V manager in a location that's accessible only to the current user and to the administrators group, and you will check how the security of the VM files and the VM Worker process change accordingly.

First, open an administrative command prompt and create a folder in one of the workstation's volumes (in the example we used C:\TestVm), using the following command:

```
md c:\TestVm
```

Then you need to strip off all the inherited ACEs (Access control entries; see Chapter 7 of Part 1 for further details) and add full access ACEs for the administrators group and the current logged-on user. The following commands perform the described actions (you need to replace C:\TestVm with the path of your directory and <UserName> with your currently logged-on user name):

```
icacls c:\TestVm /inheritance:r
icacls c:\TestVm /grant Administrators:(CI)(OI)F
icacls c:\TestVm /grant <UserName>:(CI)(OI)F
```

To verify that the folder has the correct ACL, you should open File Explorer (by pressing Win+E on your keyboard), right-click the folder, select Properties, and finally click the Security tab. You should see a window like the following one:

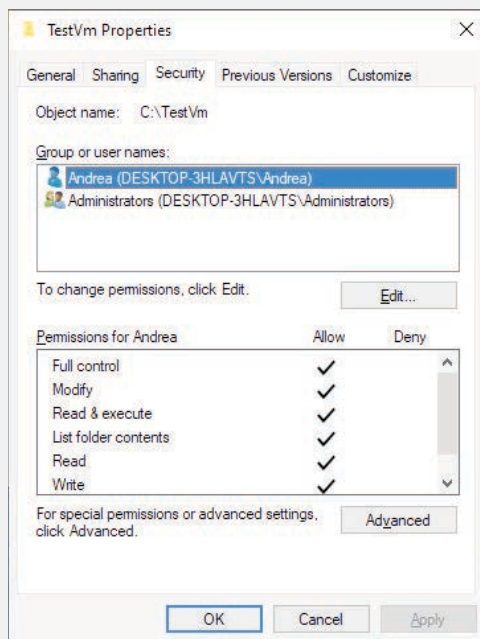

Open the Hyper-V Manager, create a VM (and its relative virtual disk), and store it in the newly created folder (procedure available at the following page: <https://docs.microsoft.com/en-us/virtualization/hyper-v-on-windows/quick-start/create-virtual-machine>). For this experiment, you don't really need to install an OS on the VM. After the New Virtual Machine Wizard ends, you should start your VM (in the example, the VM is VM1).

Open a Process Explorer as administrator and locate the vmwp.exe process. Right-click it and select Properties. As expected, you can see that the parent process is vmcompute.exe (Host Compute Service). If you click the **Security** tab, you should see that the VM SID is set as the owner of the process, and the token belongs to the Virtual Machines group:

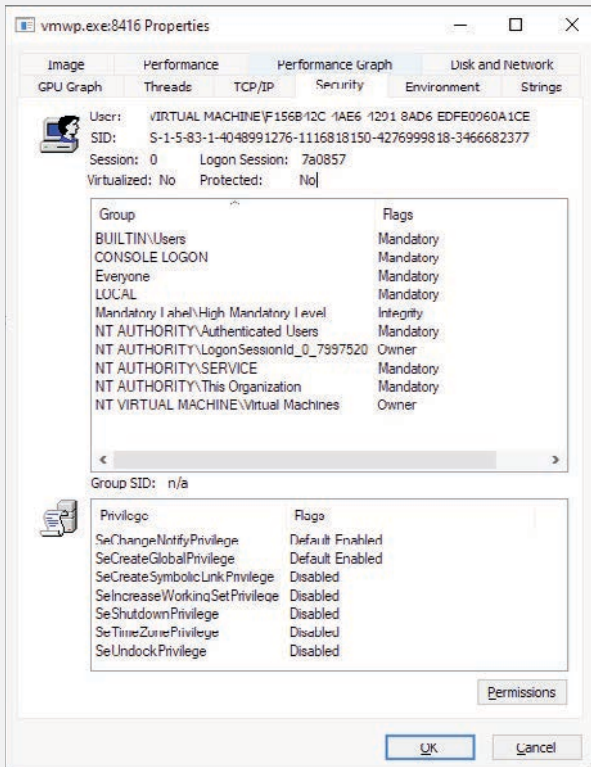

The SID is composed by reflecting the VM GUID. In the example, the VM's GUID is {F156B42C-4AE6-4291-8AD6-EDFE0960A1CE}. (You can verify it also by using PowerShell, as explained in the "Playing with the Root scheduler" experiment earlier in this chapter). A GUID is a sequence of 16-bytes, organized as one 32-bit (4 bytes) integer, two 16-bit (2 bytes) integers, and 8 final bytes. The GUID in the example is organized as:

- 0xF156B42C as the first 32-bit integer, which, in decimal, is 4048991276.
- 0x4AE6 and 0x4291 as the two 16-bit integers, which, combined as one 32-bit value, is 0x42914AE6, or 1116818150 in decimal (remember that the system is little endian, so the less significant byte is located at the lower address).
- The final byte sequence is 0x8A, 0xD6, 0xED, 0xFE, 0x09, 0x60, 0xA1 and 0xCE (the third part of the shown human readable GUID, 8AD6, is a byte sequence, and not a 16-bit value), which, combined as two 32-bit values is 0xFEEDD68A and 0CEA16009, or 4276999818 and 3466682377 in decimal.

If you combine all the calculated decimal numbers with a general SID identifier emitted by the NT authority (S-1-5) and the VM base RID (83), you should obtain the same SID shown in Process Explorer (in the example, S-1-5-83-4048991276-1116818150-4276999818-3466682377).

As you can see from Process Explorer, the VMWP process's security token does not include the Administrators group, and it hasn't been created on behalf of the logged-on user. So how is it possible that the VM Worker process can access the virtual hard disk and the VM configuration files?

The answer resides in the VMMS process, which, at VM creation time, scans each component of the VM's path and modifies the DACL of the needed folders and files. In particular, the root folder of the VM (the root folder has the same name of the VM, so you should find a subfolder in the created directory with the same name of your VM) is accessible thanks to the added virtual machines security group ACE. The virtual hard disk file is instead accessible thanks to an access-allowed ACE targeting the virtual machine's SID.

You can verify this by using File Explorer: Open the VM's virtual hard disk folder (called Virtual Hard Disks and located in the VM root folder), right-click the VHDX (or VHD) file, select **Properties**, and then click the **Security** page. You should see two new ACEs other than the one set initially. (One is the virtual machine ACE; the other one is the VmWorker process Capability for AppContainers.)

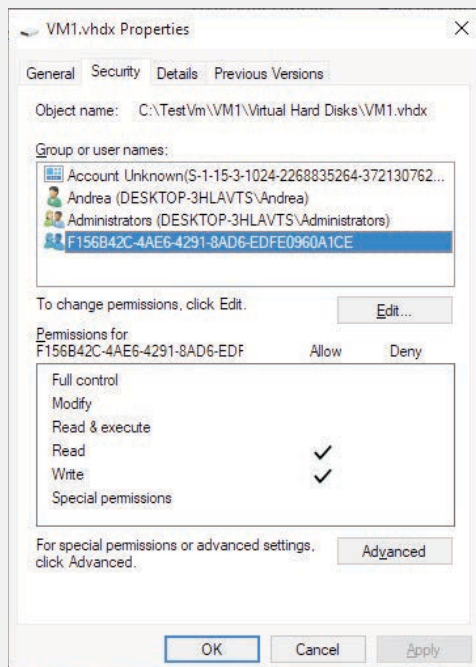

If you stop the VM and you try to delete the virtual machine ACE from the file, you will see that the VM is not able to start anymore. For restoring the correct ACL for the virtual hard disk, you can run a PowerShell script available at <https://gallery.technet.microsoft.com/Hyper-V-Restore-ACL-e64dee58>.

VMBus

VMBus is the mechanism exposed by the Hyper-V virtualization stack to provide interpartition communication between VMs. It is a virtual bus device that sets up channels between the guest and the host. These channels provide the capability to share data between partitions and set up paravirtualized (also known as synthetic) devices.

The root partition hosts Virtualization Service Providers (VSPs) that communicate over VMBus to handle device requests from child partitions. On the other end, child partitions (or guests) use Virtualization Service Consumers (VSCs) to redirect device requests to the VSP over VMBus. Child partitions require VMBus and VSC drivers to use the paravirtualized device stacks (more details on virtual hardware support are provided later in this chapter in the “Virtual hardware support” section). VMBus channels allow VSCs and VSPs to transfer data primarily through two ring buffers: upstream and downstream. These ring buffers are mapped into both partitions thanks to the hypervisor, which, as discussed in the previous section, also provides interpartition communication services through the SynIC.

One of the first virtual devices (VDEV) that the Worker process starts while powering up a VM is the VMBus VDEV (implemented in `Vmbusvdev.dll`). Its power-on routine connects the VM Worker process to the VMBus root driver (`Vmbus.sys`) by sending `VMBUS_VDEV_SETUP` IOCTL to the VMBus root device (named `\Device\RootVmBus`). The VMBus root driver orchestrates the parent endpoint of the bidirectional communication to the child VM. Its initial setup routine, which is invoked at the time the target VM isn't still powered on, has the important role to create an XPartition data structure, which is used to represent the VMBus instance of the child VM and to connect the needed SynIC synthetic interrupt sources (also known as SINT, see the “Synthetic Interrupt Controller” section earlier in this chapter for more details). In the root partition, VMBus uses two synthetic interrupt sources: one for the initial message handshaking (which happens before the channel is created) and another one for the synthetic events signaled by the ring buffers. Child partitions use only one SINT, though. The setup routine allocates the main message port in the child VM and the corresponding connection in the root, and, for each virtual processor belonging to the VM, allocates an event port and its connection (used for receiving synthetic events from the child VM).

The two synthetic interrupt sources are mapped using two ISR routines, named `KiVmbusInterrupt0` and `KiVmbusInterrupt1`. Thanks to these two routines, the root partition is ready to receive synthetic interrupts and messages from the child VM. When a message (or event) is received, the ISR queues a deferred procedure call (DPC), which checks whether the message is valid; if so, it queues a work item, which will be processed later by the system running at passive IRQL level (which has further implications on the message queue).

Once VMBus in the root partition is ready, each VSP driver in the root can use the services exposed by the VMBus kernel mode client library to allocate and offer a VMBus channel to the child VM. The VMBus kernel mode client library (abbreviated as KMCL) represents a VMBus channel through an opaque `KMODE_CLIENT_CONTEXT` data structure, which is allocated and initialized at channel creation time (when a VSP calls the `VmbChannelAllocate` API). The root VSP then normally offers the channel to the child VM by calling the `VmbChannelEnabled` API (this function in the child establishes the actual connection to the root by opening the channel). KMCL is implemented in two drivers: one running in the root partition (`Vmbkmclr.sys`) and one loaded in child partitions (`Vmbkmcl.sys`).

Offering a channel in the root is a relatively complex operation that involves the following steps:

1. The KMCL driver communicates with the VMBus root driver through the file object initialized in the VDEV power-up routine. The VMBus driver obtains the XPartition data structure representing the child partition and starts the channel offering process.
2. Lower-level services provided by the VMBus driver allocate and initialize a *LOCAL_OFFER* data structure representing a single “channel offer” and preallocate some SynIC predefined messages. VMBus then creates the synthetic event port in the root, from which the child can connect to signal events after writing data to the ring buffer. The *LOCAL_OFFER* data structure representing the offered channel is added to an internal server channels list.
3. After VMBus has created the channel, it tries to send the *OfferChannel* message to the child with the goal to inform it of the new channel. However, at this stage, VMBus fails because the other end (the child VM) is not ready yet and has not started the initial message handshake.

After all the VSPs have completed the channel offering, and all the VDEV have been powered up (see the previous section for details), the VM Worker process starts the VM. For channels to be completely initialized, and their relative connections to be started, the guest partition should load and start the VMBus child driver (*Vmbus.sys*).

Initial VMBus message handshaking

In Windows, the VMBus child driver is a WDF bus driver enumerated and started by the Pnp manager and located in the ACPI root enumerator. (Another version of the VMBus child driver is also available for Linux. VMBus for Linux is not covered in this book, though.) When the NT kernel starts in the child VM, the VMBus driver begins its execution by initializing its own internal state (which means allocating the needed data structure and work items) and by creating the `\Device\VmBus` root functional device object (FDO). The Pnp manager then calls the VMBus’s resource assignment handler routine. The latter configures the correct SINT source (by emitting a *HvSetVpRegisters* hypercall on one of the *HvRegisterSint* registers, with the help of the WinHv driver) and connects it to the *KiVmbusInterrupt2* ISR. Furthermore, it obtains the SIMP page, used for sending and receiving synthetic messages to and from the root partition (see the “Synthetic Interrupt Controller” section earlier in this chapter for more details), and creates the XPartition data structure representing the parent (root) partition.

When the request of starting the VMBus’ FDO comes from the Pnp manager, the VMBus driver starts the initial message handshaking. At this stage, each message is sent by emitting the *HvPostMessage* hypercall (with the help of the WinHv driver), which allows the hypervisor to inject a synthetic interrupt to a target partition (in this case, the target is the partition). The receiver acquires the message by simply reading from the SIMP page; the receiver signals that the message has been read from the queue by setting the new message type to *MessageTypeNone*. (See the hypervisor TLFS for more details.) The reader can think of the initial message handshake, which is represented in Figure 9-25, as a process divided in two phases.

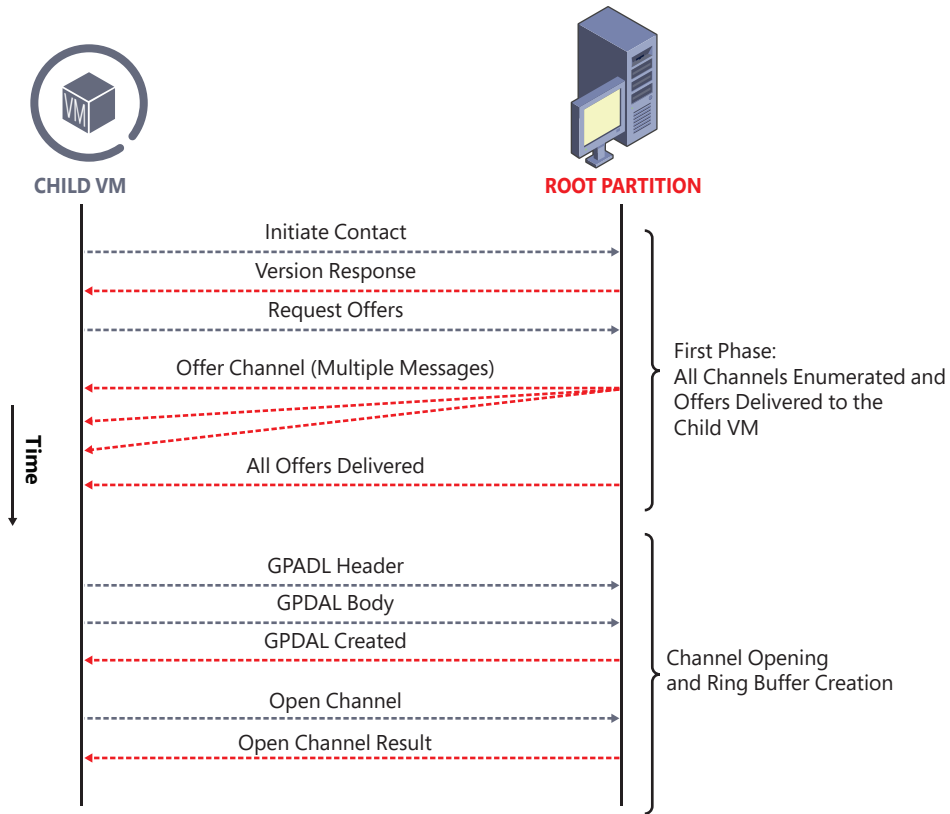

FIGURE 9-25 VMBus initial message handshake.

The first phase is represented by the *Initiate Contact* message, which is delivered once in the lifetime of the VM. This message is sent from the child VM to the root with the goal to negotiate the VMBus protocol version supported by both sides. At the time of this writing, there are five main VMBus protocol versions, with some additional slight variations. The root partition parses the message, asks the hypervisor to map the monitor pages allocated by the client (if supported by the protocol), and replies by accepting the proposed protocol version. Note that if this is not the case (which happens when the Windows version running in the root partition is lower than the one running in the child VM), the child VM restarts the process by downgrading the VMBus protocol version until a compatible version is established. At this point, the child is ready to send the *Request Offers* message, which causes the root partition to send the list of all the channels already offered by the VSPs. This allows the child partition to open the channels later in the handshaking protocol.

Figure 9-25 highlights the different synthetic messages delivered through the hypervisor for setting up the VMBus channel or channels. The root partition walks the list of the offered channels located in the Server Channels list (*LOCAL_OFFER* data structure, as discussed previously), and, for each of them, sends an *Offer Channel* message to the child VM. The message is the same as the one sent at the final stage of the channel offering protocol, which we discussed previously in the “VMBus” section. So, while

the first phase of the initial message handshake happens only once per lifetime of the VM, the second phase can start any time when a channel is offered. The *Offer Channel* message includes important data used to uniquely identify the channel, like the channel type and instance GUIDs. For VDEV channels, these two GUIDs are used by the Pnp Manager to properly identify the associated virtual device.

The child responds to the message by allocating the client *LOCAL_OFFER* data structure representing the channel and the relative XInterrupt object, and by determining whether the channel requires a physical device object (PDO) to be created, which is usually always true for VDEVs' channels. In this case, the VMBus driver creates an instance PDO representing the new channel. The created device is protected through a security descriptor that renders it accessible only from system and administrative accounts. The VMBus standard device interface, which is attached to the new PDO, maintains the association between the new VMBus channel (through the *LOCAL_OFFER* data structure) and the device object. After the PDO is created, the Pnp Manager is able to identify and load the correct VSC driver through the VDEV type and instance GUIDs included in the *Offer Channel* message. These interfaces become part of the new PDO and are visible through the Device Manager. See the following experiment for details. When the VSC driver is then loaded, it usually calls the *VmbEnableChannel* API (exposed by KMCL, as discussed previously) to "open" the channel and create the final ring buffer.

EXPERIMENT: Listing virtual devices (VDEVs) exposed through VMBus

Each VMBus channel is identified through a type and instance GUID. For channels belonging to VDEVs, the type and instance GUID also identifies the exposed device. When the VMBus child driver creates the instance PDOs, it includes the type and instance GUID of the channel in multiple devices' properties, like the instance path, hardware ID, and compatible ID. This experiment shows how to enumerate all the VDEVs built on the top of VMBus.

For this experiment, you should build and start a Windows 10 virtual machine through the Hyper-V Manager. When the virtual machine is started and runs, open the **Device Manager** (by typing its name in the Cortana search box, for example). In the Device Manager applet, click the **View** menu, and select **Device by Connection**. The VMBus bus driver is enumerated and started through the ACPI enumerator, so you should expand the ACPI x64-based PC root node and then the ACPI Module Device located in the Microsoft ACPI-Compliant System child node, as shown in the following figure:

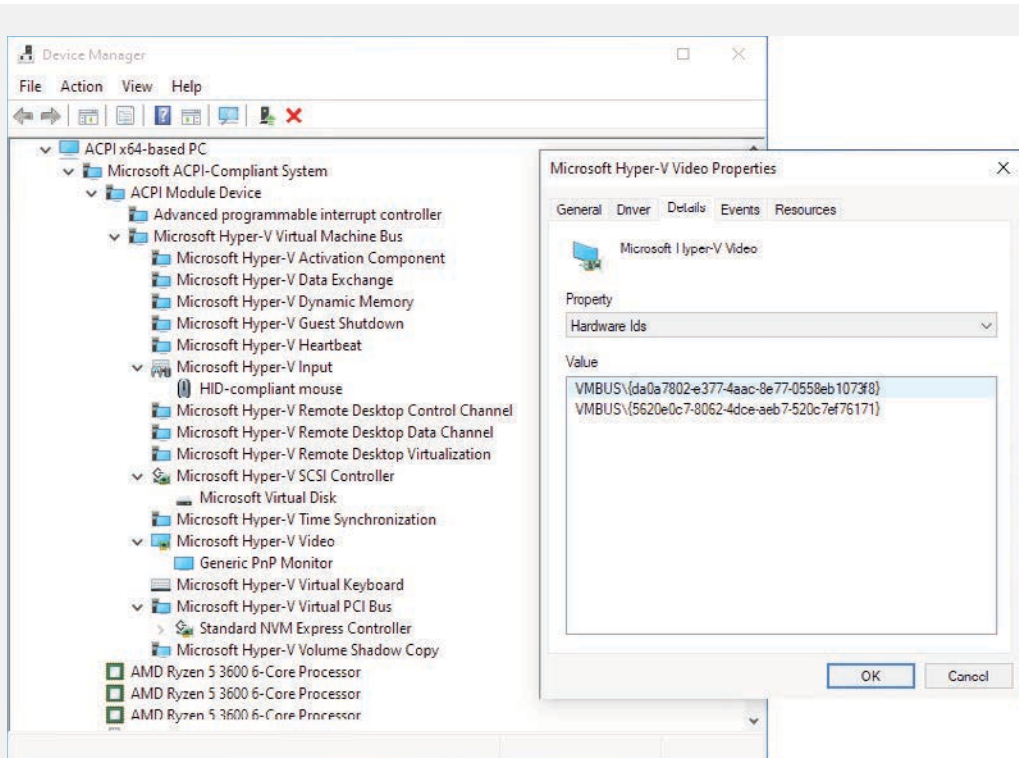

By opening the ACPI Module Device, you should find another node, called Microsoft Hyper-V Virtual Machine Bus, which represents the root VMBus PDO. Under that node, the Device Manager shows all the instance devices created by the VMBus FDO after their relative VMBus channels have been offered from the root partition.

Now right-click one of the Hyper-V devices, such as the Microsoft Hyper-V Video device, and select **Properties**. For showing the type and instance GUIDs of the VMBus channel backing the virtual device, open the **Details** tab of the **Properties** window. Three device properties include the channel's type and instance GUID (exposed in different formats): Device Instance path, Hardware ID, and Compatible ID. Although the compatible ID contains only the VMBus channel type GUID (`{da0a7802-e377-4aac-8e77-0558eb1073f8}`) in the figure), the hardware ID and device instance path contain both the type and instance GUIDs.

Opening a VMBus channel and creating the ring buffer

For correctly starting the interpartition communication and creating the ring buffer, a channel must be opened. Usually VSCs, after having allocated the client side of the channel (still through *VmbChannel Allocate*), call the *VmbChannelEnable* API exported from the KMCL driver. As introduced in the previous section, this API in the child partitions opens a VMBus channel, which has already been offered by the root. The KMCL driver communicates with the VMBus driver, obtains the channel parameters (like the channel's type, instance GUID, and used MMIO space), and creates

a work item for the received packets. It then allocates the ring buffer, which is shown in Figure 9-26. The size of the ring buffer is usually specified by the VSC through a call to the KMCL exported `VmbClientChannelInitSetRingBufferPageCount` API.

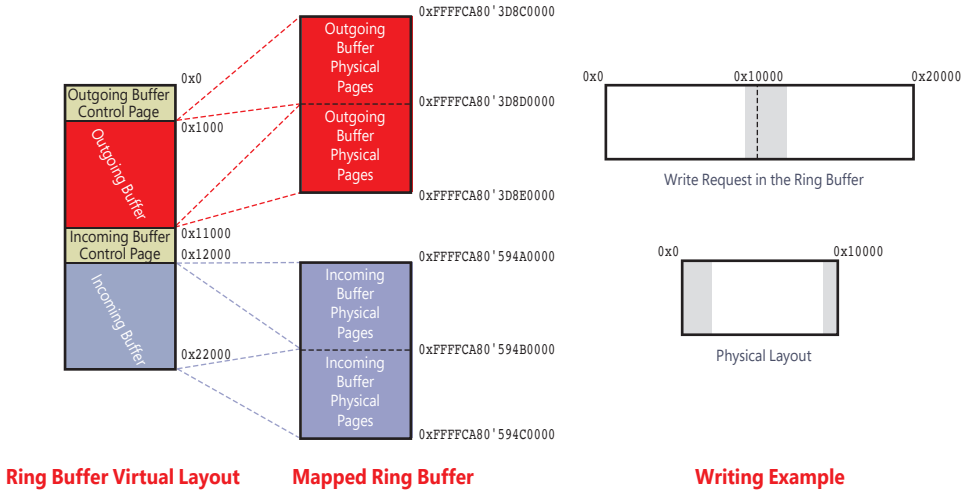

FIGURE 9-26 An example of a 16-page ring buffer allocated in the child partition.

The ring buffer is allocated from the child VM’s non-paged pool and is mapped through a memory descriptor list (MDL) using a technique called *double mapping*. (MDLs are described in Chapter 5 of Part 1.) In this technique, the allocated MDL describes a double number of the incoming (or outgoing) buffer’s physical pages. The PFN array of the MDL is filled by including the physical pages of the buffer twice: one time in the first half of the array and one time in the second half. This creates a “ring buffer.”

For example, in Figure 9-26, the incoming and outgoing buffers are 16 pages (0x10) large. The outgoing buffer is mapped at address 0xFFFFCA803D8C0000. If the sender writes a 1-KB VMBus packet to a position close to the end of the buffer, let’s say at offset 0x9FF00, the write succeeds (no access violation exception is raised), but the data will be written partially in the end of the buffer and partially in the beginning. In Figure 9-26, only 256 (0x100) bytes are written at the end of the buffer, whereas the remaining 768 (0x300) bytes are written in the start.

Both the incoming and outgoing buffers are surrounded by a control page. The page is shared between the two endpoints and composes the VM ring control block. This data structure is used to keep track of the position of the last packet written in the ring buffer. It furthermore contains some bits to control whether to send an interrupt when a packet needs to be delivered.

After the ring buffer has been created, the KMCL driver sends an IOCTL to VMBus, requesting the creation of a GPA descriptor list (GPADL). A GPADL is a data structure very similar to an MDL and is used for describing a chunk of physical memory. Differently from an MDL, the GPADL contains an array of guest physical addresses (GPAs, which are always expressed as 64-bit numbers, differently from the PFNs included in a MDL). The VMBus driver sends different messages to the root partition for transferring the entire GPADL describing both the incoming and outgoing ring buffers. (The maximum size of a synthetic message is 240 bytes, as discussed earlier.) The root partition reconstructs the entire

GPADL and stores it in an internal list. The GPADL is mapped in the root when the child VM sends the final *Open Channel* message. The root VMBus driver parses the received GPADL and maps it in its own physical address space by using services provided by the VID driver (which maintains the list of memory block ranges that comprise the VM physical address space).

At this stage the channel is ready: the child and the root partition can communicate by simply reading or writing data to the ring buffer. When a sender finishes writing its data, it calls the *VmbChannelSend SynchronousRequest* API exposed by the KMCL driver. The API invokes VMBus services to signal an event in the monitor page of the Xinterrupt object associated with the channel (old versions of the VMBus protocol used an interrupt page, which contained a bit corresponding to each channel), Alternatively, VMBus can signal an event directly in the channel's event port, which depends only on the required latency.

Other than VSCs, other components use VMBus to implement higher-level interfaces. Good examples are provided by the VMBus pipes, which are implemented in two kernel mode libraries (*Vmbuspipe.dll* and *Vmbuspiper.dll*) and rely on services exposed by the VMBus driver (through IOCTLs). Hyper-V Sockets (also known as *HvSockets*) allow high-speed interpartition communication using standard network interfaces (sockets). A client connects an *AF_HYPERV* socket type to a target VM by specifying the target VM's GUID and a GUID of the Hyper-V socket's service registration (to use *HvSockets*, both endpoints must be registered in the *HKLM\SOFTWARE\Microsoft\Windows NT\CurrentVersion\Virtualization\GuestCommunicationServices* registry key) instead of the target IP address and port. Hyper-V Sockets are implemented in multiple drivers: *HvSocket.sys* is the transport driver, which exposes low-level services used by the socket infrastructure; *HvSocketControl.sys* is the provider control driver used to load the *HvSocket* provider in case the VMBus interface is not present in the system; *HvSocket.dll* is a library that exposes supplementary socket interfaces (tied to Hyper-V sockets) callable from user mode applications. Describing the internal infrastructure of both Hyper-V Sockets and VMBus pipes is outside the scope of this book, but both are documented in Microsoft Docs.

Virtual hardware support

For properly run virtual machines, the virtualization stack needs to support virtualized devices. Hyper-V supports different kinds of virtual devices, which are implemented in multiple components of the virtualization stack. I/O to and from virtual devices is orchestrated mainly in the root OS. I/O includes storage, networking, keyboard, mouse, serial ports and GPU (graphics processing unit). The virtualization stack exposes three kinds of devices to the guest VMs:

- Emulated devices, also known—in industry-standard form—as fully virtualized devices
- Synthetic devices, also known as paravirtualized devices
- Hardware-accelerated devices, also known as direct-access devices

For performing I/O to physical devices, the processor usually reads and writes data from input and output ports (I/O ports), which belong to a device. The CPU can access I/O ports in two ways:

- Through a separate I/O address space, which is distinct from the physical memory address space and, on AMD64 platforms, consists of 64 thousand individually addressable I/O ports. This method is old and generally used for legacy devices.

- Through memory mapped I/O. Devices that respond like memory components can be accessed through the processor's physical memory address space. This means that the CPU accesses memory through standard instructions: the underlying physical memory is mapped to a device.

Figure 9-27 shows an example of an emulated device (the virtual IDE controller used in Generation 1 VMs), which uses memory-mapped I/O for transferring data to and from the virtual processor.

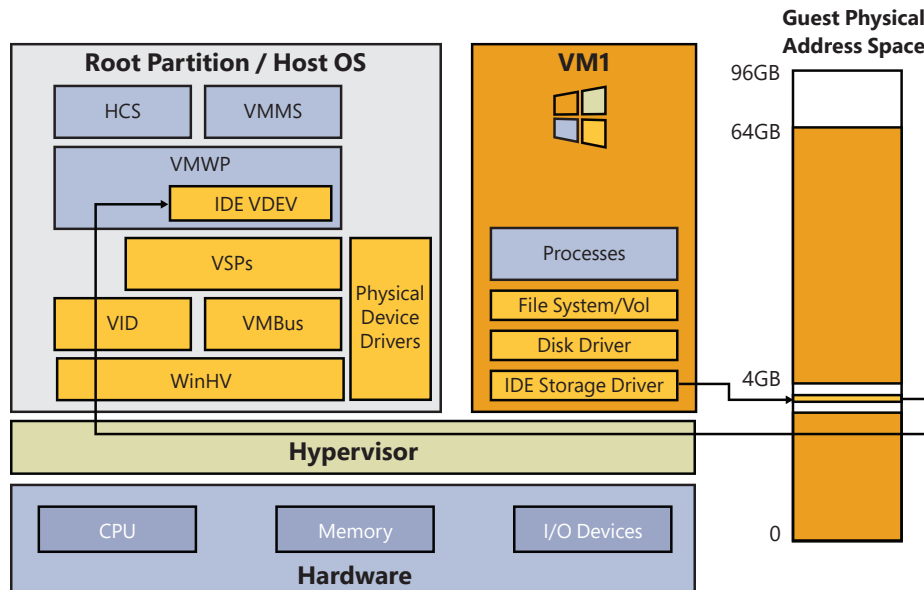

FIGURE 9-27 The virtual IDE controller, which uses emulated I/O to perform data transfer.

In this model, every time the virtual processor reads or writes to the device MMIO space or emits instructions to access the I/O ports, it causes a VMEXIT to the hypervisor. The hypervisor calls the proper intercept routine, which is dispatched to the VID driver. The VID driver builds a VID message and enqueues it in an internal queue. The queue is drained by an internal VMWP's thread, which waits and dispatches the VP's messages received from the VID driver; this thread is called the *message pump* thread and belongs to an internal thread pool initialized at VMWP creation time. The VM Worker process identifies the physical address causing the VMEXIT, which is associated with the proper virtual device (VDEV), and calls into one of the VDEV callbacks (usually read or write callback). The VDEV code uses the services provided by the instruction emulator to execute the faulting instruction and properly emulate the virtual device (an IDE controller in the example).



NOTE The full instructions emulator located in the VM Worker process is also used for other different purposes, such as to speed up cases of intercept-intensive code in a child partition. The emulator in this case allows the execution context to stay in the Worker process between intercepts, as VMEXITs have serious performance overhead. Older versions of the hardware virtualization extensions prohibit executing real-mode code in a virtual machine; for those cases, the virtualization stack was using the emulator for executing real-mode code in a VM.

Paravirtualized devices

While emulated devices always produce VMEXITs and are quite slow, Figure 9-28 shows an example of a synthetic or paravirtualized device: the synthetic storage adapter. Synthetic devices know to run in a virtualized environment; this reduces the complexity of the virtual device and allows it to achieve higher performance. Some synthetic virtual devices exist only in virtual form and don't emulate any real physical hardware (an example is synthetic RDP).

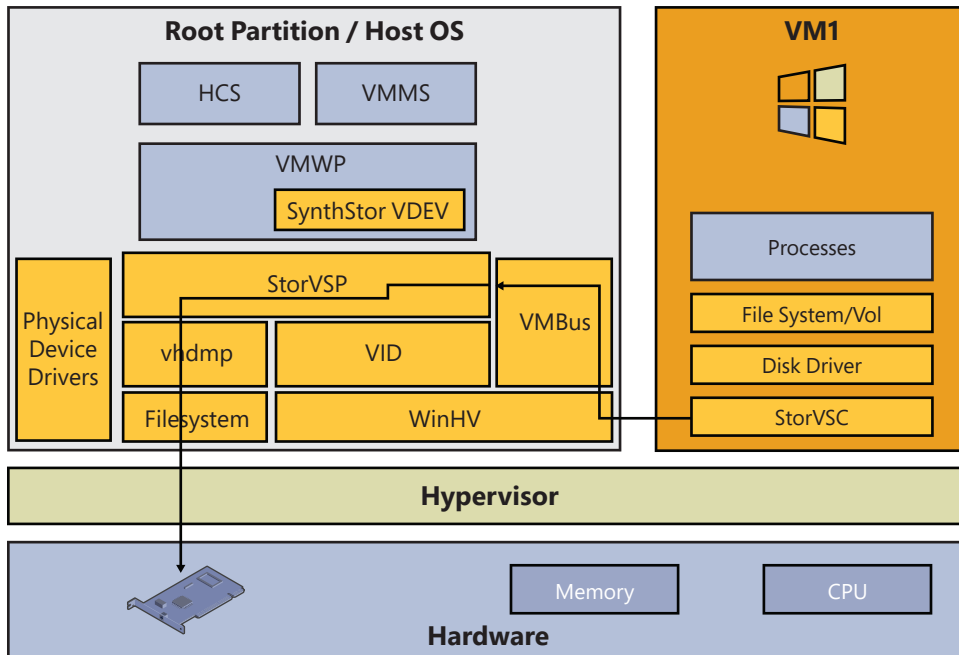

FIGURE 9-28 The storage controller paravirtualized device.

Paravirtualized devices generally require three main components:

- A virtualization service provider (VSP) driver runs in the root partition and exposes virtualization-specific interfaces to the guest thanks to the services provided by VMBus (see the previous section for details on VMBus).
- A synthetic VDEV is mapped in the VM Worker process and usually cooperates only in the start-up, teardown, save, and restore of the virtual device. It is generally not used during the regular work of the device. The synthetic VDEV initializes and allocates device-specific resources (in the example, the SynthStor VDEV initializes the virtual storage adapter), but most importantly allows the VSP to offer a VMBus communication channel to the guest VSC. The channel will be used for communication with the root and for signaling device-specific notifications via the hypervisor.
- A virtualization service consumer (VSC) driver runs in the child partition, understands the virtualization-specific interfaces exposed by the VSP, and reads/writes messages and notifications from the shared memory exposed through VMBus by the VSP. This allows the virtual device to run in the child VM faster than an emulated device.

Hardware-accelerated devices

On server SKUs, *hardware-accelerated devices* (also known as direct-access devices) allow physical devices to be remapped in the guest partition, thanks to the services exposed by the VPCI infrastructure. When a physical device supports technologies like single-root input/output virtualization (SR IOV) or Discrete Device Assignment (DDA), it can be mapped to a guest partition. The guest partition can directly access the MMIO space associated with the device and can perform DMA to and from the guest memory directly without any interception by the hypervisor. The IOMMU provides the needed security and ensures that the device can initiate DMA transfers only in the physical memory that belong to the virtual machine.

Figure 9-29 shows the components responsible in managing the hardware-accelerated devices:

- The VPCI VDEV (Vpcievdev.dll) runs in the VM Worker process. Its role is to extract the list of hardware-accelerated devices from the VM configuration file, set up the VPCI virtual bus, and assign a device to the VSP.
- The PCI Proxy driver (Pcip.sys) is responsible for dismounting and mounting a DDA-compatible physical device from the root partition. Furthermore, it has the key role in obtaining the list of resources used by the device (through the SR-IOV protocol) like the MMIO space and interrupts. The proxy driver provides access to the physical configuration space of the device and renders an “unmounted” device inaccessible to the host OS.
- The VPCI virtual service provider (Vpcivsp.sys) creates and maintains the virtual bus object, which is associated to one or more hardware-accelerated devices (which in the VPCI VSP are called *virtual devices*). The virtual devices are exposed to the guest VM through a VMBus channel created by the VSP and offered to the VSC in the guest partition.
- The VPCI virtual service client (Vpci.sys) is a WDF bus driver that runs in the guest VM. It connects to the VMBus channel exposed by the VSP, receives the list of the direct access devices exposed to the VM and their resources, and creates a PDO (physical device object) for each of them. The devices driver can then attach to the created PDOs in the same way as they do in nonvirtualized environments.

When a user wants to map a hardware-accelerated device to a VM, it uses some PowerShell commands (see the following experiment for further details), which start by “unmounting” the device from the root partition. This action forces the VMMS service to communicate with the standard PCI driver (through its exposed device, called *PciControl*). The VMMS service sends a `PCIDRIVE_ADD_VMPROXYPATH` IOCTL to the PCI driver by providing the device descriptor (in form of bus, device, and function ID). The PCI driver checks the descriptor, and, if the verification succeeded, adds it in the `HKLM\System\CurrentControlSet\Control\PnP\Pci\VmProxy` registry value. The VMMS then starts a PNP device (re)enumeration by using services exposed by the PNP manager. In the enumeration phase, the PCI driver finds the new proxy device and loads the PCI proxy driver (Pcip.sys), which marks the device as reserved for the virtualization stack and renders it invisible to the host operating system.

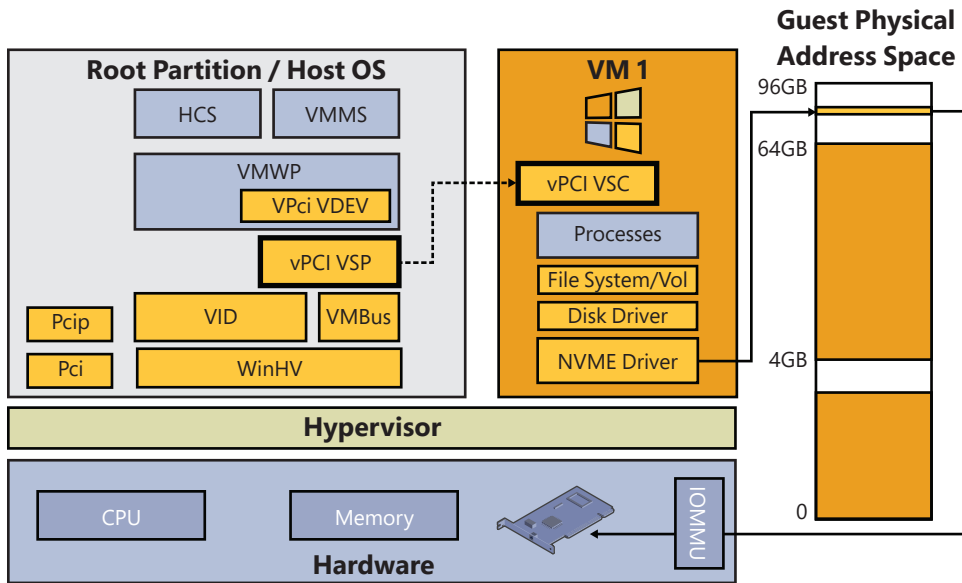

FIGURE 9-29 Hardware-accelerated devices.

The second step requires assigning the device to a VM. In this case, the VMMS writes the device descriptor in the VM configuration file. When the VM is started, the VPCI VDEV (*vpcievdev.dll*) reads the direct-access device’s descriptor from the VM configuration, and starts a complex configuration phase that is orchestrated mainly by the VPCI VSP (*Vpcivsp.sys*). Indeed, in its “power on” callback, the VPCI VDEV sends different IOCTLs to the VPCI VSP (which runs in the root partition), with the goal to perform the creation of the virtual bus and the assignment of hardware-accelerated devices to the guest VM.

A “virtual bus” is a data structure used by the VPCI infrastructure as a “glue” to maintain the connection between the root partition, the guest VM, and the direct-access devices assigned to it. The VPCI VSP allocates and starts the VMBus channel offered to the guest VM and encapsulates it in the virtual bus. Furthermore, the virtual bus includes some pointers to important data structures, like some allocated VMBus packets used for the bidirectional communication, the guest power state, and so on. After the virtual bus is created, the VPCI VSP performs the device assignment.

A hardware-accelerated device is internally identified by a LUID and is represented by a virtual device object, which is allocated by the VPCI VSP. Based on the device’s LUID, the VPCI VSP locates the proper proxy driver, which is also known as Mux driver—it’s usually *Pcip.sys*. The VPCI VSP queries the SR-IOV or DDA interfaces from the proxy driver and uses them to obtain the Plug and Play information (hardware descriptor) of the direct-access device and to collect the resource requirements (MMIO space, BAR registers, and DMA channels). At this point, the device is ready to be attached to the guest VM: the VPCI VSP uses the services exposed by the WinHvr driver to emit the *HvAttachDevice* hypercall to the hypervisor, which reconfigures the system IOMMU for mapping the device’s address space in the guest partition.

The guest VM is aware of the mapped device thanks to the VPCI VSC (*Vpci.sys*). The VPCI VSC is a WDF bus driver enumerated and launched by the VMBus bus driver located in the guest VM. It is

composed of two main components: a FDO (functional device object) created at VM boot time, and one or more PDOs (physical device objects) representing the physical direct-access devices remapped in the guest VM. When the VPCI VSC bus driver is executed in the guest VM, it creates and starts the client part of the VMBus channel used to exchange messages with the VSP. "Send bus relations" is the first message sent by the VPCI VSC through the VMBus channel. The VSP in the root partition responds by sending the list of hardware IDs describing the hardware-accelerated devices currently attached to the VM. When the PNP manager requires the new device relations to the VPCI VSC, the latter creates a new PDO for each discovered direct-access device. The VSC driver sends another message to the VSP with the goal of requesting the resources used by the PDO.

After the initial setup is done, the VSC and VSP are rarely involved in the device management. The specific hardware-accelerated device's driver in the guest VM attaches to the relative PDO and manages the peripheral as if it had been installed on a physical machine.

EXPERIMENT: Mapping a hardware-accelerated NVMe disk to a VM

As explained in the previous section, physical devices that support SR-IOV and DDE technologies can be directly mapped in a guest VM running in a Windows Server 2019 host. In this experiment, we are mapping an NVMe disk, which is connected to the system through the PCI-Ex bus and supports DDE, to a Windows 10 VM. (Windows Server 2019 also supports the direct assignment of a graphics card, but this is outside the scope of this experiment.)

As explained at <https://docs.microsoft.com/en-us/virtualization/community/team-blog/2015/20151120-discrete-device-assignment-machines-and-devices>, for being able to be reassigned, a device should have certain characteristics, such as supporting message-signaled interrupts and memory-mapped I/O. Furthermore, the machine in which the hypervisor runs should support SR-IOV and have a proper I/O MMU. For this experiment, you should start by verifying that the SR-IOV standard is enabled in the system BIOS (not explained here; the procedure varies based on the manufacturer of your machine).

The next step is to download a PowerShell script that verifies whether your NVMe controller is compatible with Discrete Device Assignment. You should download the `survey-dda.ps1` PowerShell script from <https://github.com/MicrosoftDocs/Virtualization-Documentation/tree/master/hyperv-samples/benarm-powershell/DDA>. Open an administrative PowerShell window (by typing **PowerShell** in the Cortana search box and selecting **Run As Administrator**) and check whether the PowerShell script execution policy is set to unrestricted by running the **Get-ExecutionPolicy** command. If the command yields some output different than **Unrestricted**, you should type the following: **Set-ExecutionPolicy -Scope LocalMachine -ExecutionPolicy Unrestricted**, press **Enter**, and confirm with **Y**.

If you execute the downloaded `survey-dda.ps1` script, its output should highlight whether your NVMe device can be reassigned to the guest VM. Here is a valid output example:

```
Standard NVM Express Controller
Express Endpoint -- more secure.
And its interrupts are message-based, assignment can work.
PCIR00T(0)#PCI(0302)#PCI(0000)
```

Take note of the location path (the `PCIROOT(0)#PCI(0302)#PCI(0000)` string in the example). Now we will set the automatic stop action for the target VM as turned-off (a required step for DDA) and dismount the device. In our example, the VM is called "Vibranium." Write the following commands in your PowerShell window (by replacing the sample VM name and device location with your own):

```
Set-VM -Name "Vibranium" -AutomaticStopAction TurnOff
Dismount-VMHostAssignableDevice -LocationPath "PCIROOT(0)#PCI(0302)#PCI(0000)"
```

In case the last command yields an operation failed error, it is likely that you haven't disabled the device. Open the **Device Manager**, locate your NVMe controller (Standard NVMe Express Controller in this example), right-click it, and select **Disable Device**. Then you can type the last command again. It should succeed this time. Then assign the device to your VM by typing the following:

```
Add-VMAssignableDevice -LocationPath "PCIROOT(0)#PCI(0302)#PCI(0000)" -VMName "Vibranium"
```

The last command should have completely removed the NVMe controller from the host. You should verify this by checking the Device Manager in the host system. Now it's time to power up the VM. You can use the Hyper-V Manager tool or PowerShell. If you start the VM and get an error like the following, your BIOS is not properly configured to expose SR-IOV, or your I/O MMU doesn't have the required characteristics (most likely it does not support I/O remapping).

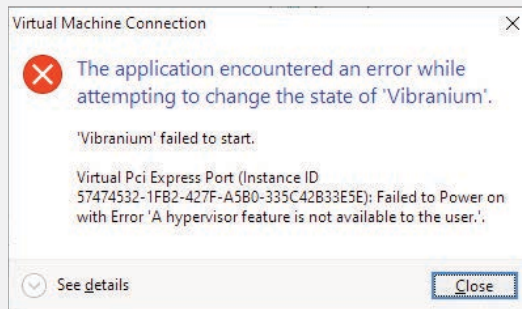

Otherwise, the VM should simply boot as expected. In this case, you should be able to see both the NVMe controller and the NVMe disk listed in the Device Manager applet of the child VM. You can use the disk management tool to create partitions in the child VM in the same way you do in the host OS. The NVMe disk will run at full speed with no performance penalties (you can confirm this by using any disk benchmark tool).

To properly remove the device from the VM and remount it in the host OS, you should first shut down the VM and then use the following commands (remember to always change the virtual machine name and NVMe controller location):

```
Remove-VMAssignableDevice -LocationPath "PCIROOT(0)#PCI(0302)#PCI(0000)" -VMName
"Vibranium"
Mount-VMHostAssignableDevice -LocationPath "PCIROOT(0)#PCI(0302)#PCI(0000)"
```

After the last command, the NVMe controller should reappear listed in the Device Manager of the host OS. You just need to reenable it for restarting to use the NVMe disk in the host.

VA-backed virtual machines

Virtual machines are being used for multiple purposes. One of them is to properly run traditional software in isolated environments, called *containers*. (Server and application silos, which are two types of containers, have been introduced in Part 1, Chapter 3, “Processes and jobs.”) Fully isolated containers (internally named Xenon and Krypton) require a fast-startup type, low overhead, and the possibility of getting the lowest possible memory footprint. Guest physical memory of this type of VM is generally shared between multiple containers. Good examples of containers are provided by Windows Defender Application Guard, which uses a container to provide the full isolation of the browser, or by Windows Sandbox, which uses containers to provide a fully isolated virtual environment. Usually a container shares the same VM’s firmware, operating system, and, often, also some applications running in it (the shared components compose the base layer of a container). Running each container in its private guest physical memory space would not be feasible and would result in a high waste of physical memory.

To solve the problem, the virtualization stack provides support for VA-backed virtual machines. VA-backed VMs use the host’s operating system’s memory manager to provide to the guest partition’s physical memory advanced features like memory deduplication, memory trimming, direct maps, memory cloning and, most important, paging (all these concepts have been extensively covered in Chapter 5 of Part 1). For traditional VMs, guest memory is assigned by the VID driver by statically allocating system physical pages from the host and mapping them in the GPA space of the VM before any virtual processor has the chance to execute, but for VA-backed VMs, a new layer of indirection is added between the GPA space and SPA space. Instead of mapping SPA pages directly into the GPA space, the VID creates a GPA space that is initially blank, creates a user mode minimal process (called VMMEM) for hosting a VA space, and sets up GPA to VA mappings using MicroVM. MicroVM is a new component of the NT kernel tightly integrated with the NT memory manager that is ultimately responsible for managing the GPA to SPA mapping by composing the GPA to VA mapping (maintained by the VID) with the VA to SPA mapping (maintained by the NT memory manager).

The new layer of indirection allows VA-backed VMs to take advantage of most memory management features that are exposed to Windows processes. As discussed in the previous section, the VM Worker process, when it starts the VM, asks the VID driver to create the partition’s memory block. In case the VM is VA-backed, it creates the Memory Block Range GPA mapping bitmap, which is used to keep track of the allocated virtual pages backing the new VM’s RAM. It then creates the partition’s RAM memory, backed by a big range of VA space. The VA space is usually as big as the allocated amount of VM’s RAM memory (note that this is not a necessary condition: different VA-ranges can be mapped as different GPA ranges) and is reserved in the context of the VMMEM process using the native *NtAllocateVirtualMemory* API.

If the “deferred commit” optimization is not enabled (see the next section for more details), the VID driver performs another call to the *NtAllocateVirtualMemory* API with the goal of committing the entire VA range. As discussed in Chapter 5 of Part 1, committing memory charges the system commit limit but still doesn’t allocate any physical page (all the PTE entries describing the entire range are invalid demand-zero PTEs). The VID driver at this stage uses Winhvr to ask the hypervisor to map the entire partition’s GPA space to a special invalid SPA (by using the same *HvMapGpaPages* hypercall used for standard partitions). When the guest partition accesses guest physical memory that is mapped in the

SLAT table by the special invalid SPA, it causes a VMEXIT to the hypervisor, which recognizes the special value and injects a memory intercept to the root partition.

The VID driver finally notifies MicroVM of the new VA-backed GPA range by invoking the *VmCreateMemoryRange* routine (MicroVM services are exposed by the NT kernel to the VID driver through a Kernel Extension). MicroVM allocates and initializes a *VM_PROCESS_CONTEXT* data structure, which contains two important RB trees: one describing the allocated GPA ranges in the VM and one describing the corresponding system virtual address (SVA) ranges in the root partition. A pointer to the allocated data structure is then stored in the EPROCESS of the VMMEM instance.

When the VM Worker process wants to write into the memory of the VA-backed VM, or when a memory intercept is generated due to an invalid GPA to SPA translation, the VID driver calls into the MicroVM page fault handler (*VmAccessFault*). The handler performs two important operations: first, it resolves the fault by inserting a valid PTE in the page table describing the faulting virtual page (more details in Chapter 5 of Part 1) and then updates the SLAT table of the child VM (by calling the WinHvr driver, which emits another *HvMapGpaPages* hypercall). Afterward, the VM's guest physical pages can be paged out simply because private process memory is normally pageable. This has the important implication that it requires the majority of the MicroVM's function to operate at passive IRQL.

Multiple services of the NT memory manager can be used for VA-backed VMs. In particular, *clone templates* allow the memory of two different VA-backed VMs to be quickly cloned; *direct map* allows shared executable images or data files to have their section objects mapped into the VMMEM process and into a GPA range pointing to that VA region. The underlying physical pages can be shared between different VMs and host processes, leading to improved memory density.

VA-backed VMs optimizations

As introduced in the previous section, the cost of a guest access to dynamically backed memory that isn't currently backed, or does not grant the required permissions, can be quite expensive: when a guest access attempt is made to inaccessible memory, a VMEXIT occurs, which requires the hypervisor to suspend the guest VP, schedule the root partition's VP, and inject a memory intercept message to it. The VID's intercept callback handler is invoked at high IRQL, but processing the request and calling into MicroVM requires running at *PASSIVE_LEVEL*. Thus, a DPC is queued. The DPC routine sets an event that wakes up the appropriate thread in charge of processing the intercept. After the MicroVM page fault handler has resolved the fault and called the hypervisor to update the SLAT entry (through another hypercall, which produces another VMEXIT), it resumes the guest's VP.

Large numbers of memory intercepts generated at runtime result in big performance penalties. With the goal to avoid this, multiple optimizations have been implemented in the form of guest enlightenments (or simple configurations):

- Memory zeroing enlightenments
- Memory access hints
- Enlightened page fault
- Deferred commit and other optimizations

Memory-zeroing enlightenments

To avoid information disclosure to a VM of memory artifacts previously in use by the root partition or another VM, memory-backing guest RAM is zeroed before being mapped for access by the guest. Typically, an operating system zeroes all physical memory during boot because on a physical system the contents are nondeterministic. For a VM, this means that memory may be zeroed twice: once by the virtualization host and again by the guest operating system. For *physically* backed VMs, this is at best a waste of CPU cycles. For VA-backed VMs, the zeroing by the guest OS generates costly memory intercepts. To avoid the wasted intercepts, the hypervisor exposes the memory-zeroing enlightenments.

When the Windows Loader loads the main operating system, it uses services provided by the UEFI firmware to get the machine's physical memory map. When the hypervisor starts a VA-backed VM, it exposes the *HvGetBootZeroedMemory* hypercall, which the Windows Loader can use to query the list of physical memory ranges that are actually already zeroed. Before transferring the execution to the NT kernel, the Windows Loader merges the obtained zeroed ranges with the list of physical memory descriptors obtained through EFI services and stored in the Loader block (further details on startup mechanisms are available in Chapter 12). The NT kernel inserts the merged descriptor directly in the zeroed pages list by skipping the initial memory zeroing.

In a similar way, the hypervisor supports the hot-add memory zeroing enlightenment with a simple implementation: When the dynamic memory VSC driver (*dmvsc.sys*) initiates the request to add physical memory to the NT kernel, it specifies the *MM_ADD_PHYSICAL_MEMORY_ALREADY_ZEROED* flag, which hints the Memory Manager (MM) to add the new pages directly to the zeroed pages list.

Memory access hints

For *physically* backed VMs, the root partition has very limited information about how guest MM intends to use its physical pages. For these VMs, the information is mostly irrelevant because almost all memory and GPA mappings are created when the VM is started, and they remain statically mapped. For VA-backed VMs, this information can instead be very useful because the host memory manager manages the working set of the minimal process that contains the VM's memory (VMMEM).

The hot hint allows the guest to indicate that a set of physical pages should be mapped into the guest because they will be accessed soon or frequently. This implies that the pages are added to the working set of the minimal process. The VID handles the hint by telling MicroVM to fault in the physical pages immediately and not to remove them from the VMMEM process's working set.

In a similar way, the cold hint allows the guest to indicate that a set of physical pages should be unmapped from the guest because it will not be used soon. The VID driver handles the hint by forwarding it to MicroVM, which immediately removes the pages from the working set. Typically, the guest uses the cold hint for pages that have been zeroed by the background zero page thread (see Chapter 5 of Part 1 for more details).

The VA-backed guest partition specifies a memory hint for a page by using the *HvMemoryHeatHint* hypercall.

Enlightened page fault (EPF)

Enlightened page fault (EPF) handling is a feature that allows the VA-backed guest partition to reschedule threads on a VP that caused a memory intercept for a VA-backed GPA page. Normally, a memory intercept for such a page is handled by synchronously resolving the access fault in the root partition and resuming the VP upon access fault completion. When EPF is enabled and a memory intercept occurs for a VA-backed GPA page, the VID driver in the root partition creates a background worker thread that calls the MicroVM page fault handler and delivers a synchronous exception (not to be confused by an asynchronous interrupt) to the guest's VP, with the goal to let it know that the current thread caused a memory intercept.

The guest reschedules the thread; meanwhile, the host is handling the access fault. Once the access fault has been completed, the VID driver will add the original faulting GPA to a completion queue and deliver an asynchronous interrupt to the guest. The interrupt causes the guest to check the completion queue and unblock any threads that were waiting on EPF completion.

Deferred commit and other optimizations

Deferred commit is an optimization that, if enabled, forces the VID driver not to commit each backing page until first access. This potentially allows more VMs to run simultaneously without increasing the size of the page file, but, since the backing VA space is only reserved, and not committed, the VMs may crash at runtime due to the commitment limit being reached in the root partition. In this case, there is no more free memory available.

Other optimizations are available to set the size of the pages which will be allocated by the MicroVM page fault handler (small versus large) and to *pin* the backing pages upon first access. This prevents aging and trimming, generally resulting in more consistent performance, but consumes more memory and reduces the memory density.

The VMMEM process

The VMMEM process exists mainly for two main reasons:

- Hosts the VP-dispatch thread loop when the root scheduler is enabled, which represents the guest VP schedulable unit
- Hosts the VA space for the VA-backed VMs

The VMMEM process is created by the VID driver while creating the VM's partition. As for regular partitions (see the previous section for details), the VM Worker process initializes the VM setup through the VID.dll library, which calls into the VID through an IOCTL. If the VID driver detects that the new partition is VA-backed, it calls into the MicroVM (through the *VsmmNtSlatMemoryProcessCreate* function) to create the minimal process. MicroVM uses the *PsCreateMinimalProcess* function, which allocates the process, creates its address space, and inserts the process into the process list. It then reserves the bottom 4 GB of address space to ensure that no direct-mapped images end up there (this can reduce the entropy and security for the guest). The VID driver applies a specific security descriptor to the new VMMEM process; only the SYSTEM and the VM Worker process can access it. (The VM Worker process is launched with a specific token; the token's owner is set to a SID generated from the VM's unique

GUID.) This is important because the virtual address space of the VMMEM process could have been accessible to anyone otherwise. By reading the process virtual memory, a malicious user could read the VM private guest physical memory.

Virtualization-based security (VBS)

As discussed in the previous section, Hyper-V provides the services needed for managing and running virtual machines on Windows systems. The hypervisor guarantees the necessary isolation between each partition. In this way, a virtual machine can't interfere with the execution of another one. In this section, we describe another important component of the Windows virtualization infrastructure: the Secure Kernel, which provides the basic services for the virtualization-based security.

First, we list the services provided by the Secure Kernel and its requirements, and then we describe its architecture and basic components. Furthermore, we present some of its basic internal data structures. Then we discuss the Secure Kernel and Virtual Secure Mode startup method, describing its high dependency on the hypervisor. We conclude by analyzing the components that are built on the top of Secure Kernel, like the Isolated User Mode, Hypervisor Enforced Code Integrity, the secure software enclaves, secure devices, and Windows kernel hot-patching and microcode services.

Virtual trust levels (VTLs) and Virtual Secure Mode (VSM)

As discussed in the previous section, the hypervisor uses the SLAT to maintain each partition in its own memory space. The operating system that runs in a partition accesses memory using the standard way (guest virtual addresses are translated in guest physical addresses by using page tables). Under the cover, the hardware translates all the partition GPAs to real SPAs and then performs the actual memory access. This last translation layer is maintained by the hypervisor, which uses a separate SLAT table per partition. In a similar way, the hypervisor can use SLAT to create different security domains in a single partition. Thanks to this feature, Microsoft designed the Secure Kernel, which is the base of the Virtual Secure Mode.

Traditionally, the operating system has had a single physical address space, and the software running at ring 0 (that is, kernel mode) could have access to any physical memory address. Thus, if any software running in supervisor mode (kernel, drivers, and so on) becomes compromised, the entire system becomes compromised too. Virtual secure mode leverages the hypervisor to provide new trust boundaries for systems software. With VSM, security boundaries (described by the hypervisor using SLAT) can be put in place that limit the resources supervisor mode code can access. Thus, with VSM, even if supervisor mode code is compromised, the entire system is not compromised.

VSM provides these boundaries through the concept of virtual trust levels (VTLs). At its core, a VTL is a set of access protections on physical memory. Each VTL can have a different set of access protections. In this way, VTLs can be used to provide memory isolation. A VTL's memory access protections can be

configured to limit what physical memory a VTL can access. With VSM, a virtual processor is always running at a particular VTL and can access only physical memory that is marked as accessible through the hypervisor SLAT. For example, if a processor is running at VTL 0, it can only access memory as controlled by the memory access protections associated with VTL 0. This memory access enforcement happens at the guest physical memory translation level and thus cannot be changed by supervisor mode code in the partition.

VTLs are organized as a hierarchy. Higher levels are more privileged than lower levels, and higher levels can adjust the memory access protections for lower levels. Thus, software running at VTL 1 can adjust the memory access protections of VTL 0 to limit what memory VTL 0 can access. This allows software at VTL 1 to hide (isolate) memory from VTL 0. This is an important concept that is the basis of the VSM. Currently the hypervisor supports only two VTLs: VTL 0 represents the Normal OS execution environment, which the user interacts with; VTL 1 represents the Secure Mode, where the Secure Kernel and Isolated User Mode (IUM) runs. Because VTL 0 is the environment in which the standard operating system and applications run, it is often referred to as the normal mode.



Note The VSM architecture was initially designed to support a maximum of 16 VTLs. At the time of this writing, only 2 VTLs are supported by the hypervisor. In the future, it could be possible that Microsoft will add one or more new VTLs. For example, latest versions of Windows Server running in Azure also support Confidential VMs, which run their Host Compatibility Layer (HCL) in VTL 2.

Each VTL has the following characteristics associated with it:

- **Memory access protection** As already discussed, each virtual trust level has a set of guest physical memory access protections, which defines how the software can access memory.
- **Virtual processor state** A virtual processor in the hypervisor share some registers with each VTL, whereas some other registers are private per each VTL. The private virtual processor state for a VTL cannot be accessed by software running at a lower VTL. This allows for isolation of the processor state between VTLs.
- **Interrupt subsystem** Each VTL has a unique interrupt subsystem (managed by the hypervisor synthetic interrupt controller). A VTL's interrupt subsystem cannot be accessed by software running at a lower VTL. This allows for interrupts to be managed securely at a particular VTL without risk of a lower VTL generating unexpected interrupts or masking interrupts.

Figure 9-30 shows a scheme of the memory protection provided by the hypervisor to the Virtual Secure Mode. The hypervisor represents each VTL of the virtual processor through a different VMCS data structure (see the previous section for more details), which includes a specific SLAT table. In this way, software that runs in a particular VTL can access just the physical memory pages assigned to its level. The important concept is that the SLAT protection is applied to the *physical* pages and not to the *virtual* pages, which are protected by the standard page tables.

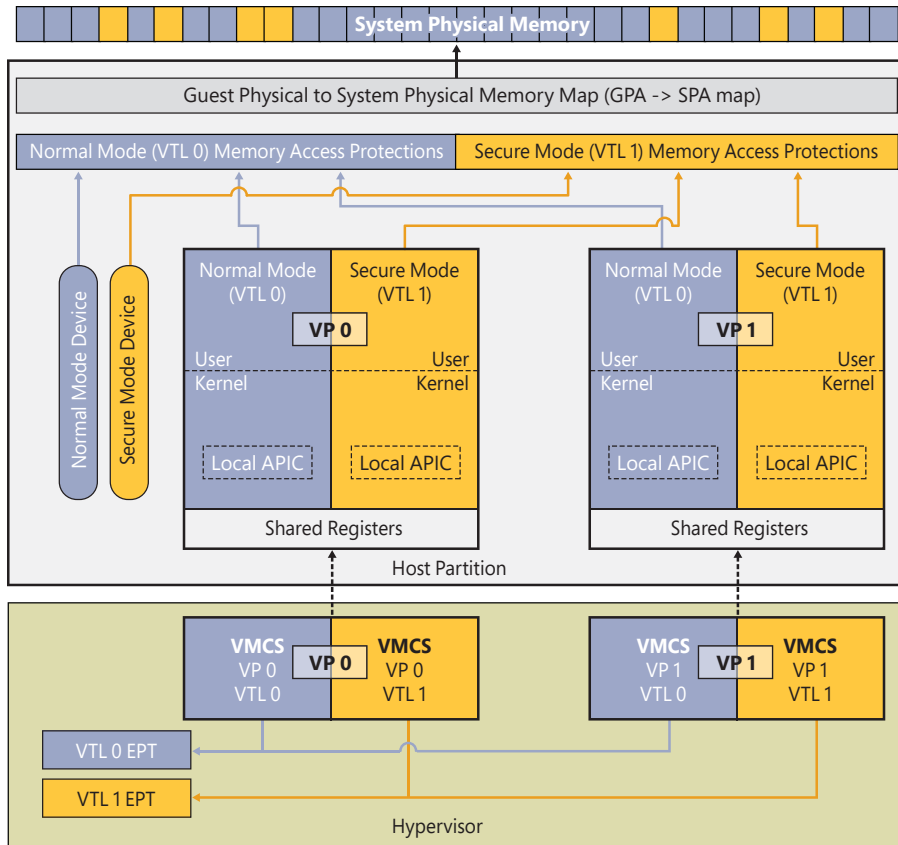

FIGURE 9-30 Scheme of the memory protection architecture provided by the hypervisor to VSM.

Services provided by the VSM and requirements

Virtual Secure Mode, which is built on the top of the hypervisor, provides the following services to the Windows ecosystem:

- Isolation** IUM provides a hardware-based isolated environment for each software that runs in VTL 1. Secure devices managed by the Secure Kernel are isolated from the rest of the system and run in VTL 1 user mode. Software that runs in VTL 1 usually stores secrets that can't be intercepted or revealed in VTL 0. This service is used heavily by Credential Guard. Credential Guard is the feature that stores all the system credentials in the memory address space of the Lsalso trustlet, which runs in VTL 1 user mode.
- Control over VTL 0** The Hypervisor Enforced Code Integrity (HVCI) checks the integrity and the signing of each module that the normal OS loads and runs. The integrity check is done entirely in VTL 1 (which has access to all the VTL 0 physical memory). No VTL 0 software can interfere with the signing check. Furthermore, HVCI guarantees that all the normal mode memory pages that contain executable code are marked as not writable (this feature is called W^X. Both HVCI and W^X have been discussed in Chapter 7 of Part 1).

- **Secure intercepts** VSM provides a mechanism to allow a higher VTL to lock down critical system resources and prevent access to them by lower VTLs. Secure intercepts are used extensively by HyperGuard, which provides another protection layer for the VTL 0 kernel by stopping malicious modifications of critical components of the operating systems.
- **VBS-based enclaves** A *security enclave* is an isolated region of memory within the address space of a user mode process. The enclave memory region is not accessible even to higher privilege levels. The original implementation of this technology was using hardware facilities to properly encrypt memory belonging to a process. A VBS-based enclave is a secure enclave whose isolation guarantees are provided using VSM.
- **Kernel Control Flow Guard** VSM, when HVCI is enabled, provides Control Flow Guard (CFG) to each kernel module loaded in the normal world (and to the NT kernel itself). Kernel mode software running in normal world has read-only access to the bitmap, so an exploit can't potentially modify it. Thanks to this reason, kernel CFG in Windows is also known as Secure Kernel CFG (SKCFG).



Note CFG is the Microsoft implementation of Control Flow Integrity, a technique that prevents a wide variety of malicious attacks from redirecting the flow of the execution of a program. Both user mode and Kernel mode CFG have been discussed extensively in Chapter 7 of Part 1.

- **Secure devices** Secure devices are a new kind of devices that are mapped and managed entirely by the Secure Kernel in VTL 1. Drivers for these kinds of devices work entirely in VTL 1 user mode and use services provided by the Secure Kernel to map the device I/O space.

To be properly enabled and work correctly, the VSM has some hardware requirements. The host system must support virtualization extensions (Intel VT-x, AMD SVM, or ARM TrustZone) and the SLAT. VSM won't work if one of the previous hardware features is not present in the system processor. Some other hardware features are not strictly necessary, but in case they are not present, some security premises of VSM may not be guaranteed:

- An IOMMU is needed to protect against physical device DMA attacks. If the system processors don't have an IOMMU, VSM can still work but is vulnerable to these physical device attacks.
- A UEFI BIOS with Secure Boot enabled is needed for protecting the boot chain that leads to the startup of the hypervisor and the Secure Kernel. If Secure Boot is not enabled, the system is vulnerable to boot attacks, which can modify the integrity of the hypervisor and Secure Kernel before they have the chances to get executed.

Some other components are optional, but when they're present they increase the overall security and responsiveness of the system. The TPM presence is a good example. It is used by the Secure Kernel to store the Master Encryption key and to perform Secure Launch (also known as DRTM; see Chapter 12 for more details). Another hardware component that can improve VSM responsiveness is the processor's Mode-Based Execute Control (MBEC) hardware support: MBEC is used when HVCI is enabled to protect the execution state of user mode pages in kernel mode. With Hardware MBEC, the hypervisor

can set the executable state of a physical memory page based on the CPL (kernel or user) domain of the specific VTL. In this way, memory that belongs to user mode application can be physically marked executable only by user mode code (kernel exploits can no longer execute their own code located in the memory of a user mode application). In case hardware MBEC is not present, the hypervisor needs to emulate it, by using two different SLAT tables for VTL 0 and switching them when the code execution changes the CPL security domain (going from user mode to kernel mode and vice versa produces a VMEXIT in this case). More details on HVCI have been already discussed in Chapter 7 of Part 1.

EXPERIMENT: Detecting VBS and its provided services

In Chapter 12, we discuss the VSM startup policy and provide the instructions to manually enable or disable Virtualization-Based Security. In this experiment, we determine the state of the different features provided by the hypervisor and the Secure Kernel. VBS is a technology that is not directly visible to the user. The System Information tool distributed with the base Windows installation is able to show the details about the Secure Kernel and its related technologies. You can start it by typing **msinfo32** in the Cortana search box. Be sure to run it as Administrator; certain details require a full-privileged user account.

In the following figure, VBS is enabled and includes HVCI (specified as Hypervisor Enforced Code Integrity), UEFI runtime virtualization (specified as UEFI Readonly), MBEC (specified as Mode Based Execution Control). However, the system described in the example does not include an enabled Secure Boot and does not have a working IOMMU (specified as DMA Protection in the Virtualization-Based Security Available Security Properties line).

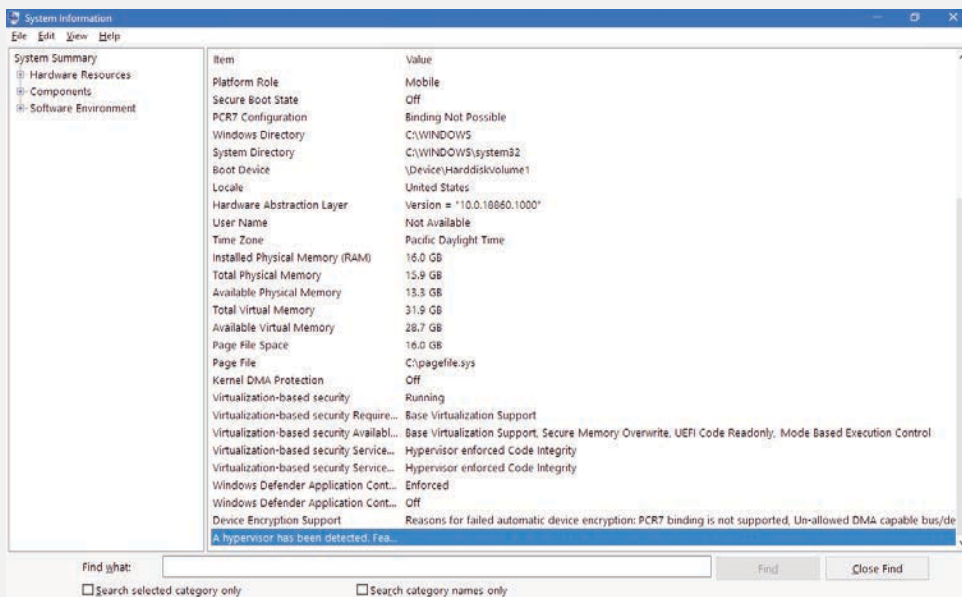

More details about how to enable, disable, and lock the VBS configuration are available in the "Understanding the VSM policy" experiment of Chapter 12.

The Secure Kernel

The Secure Kernel is implemented mainly in the `securekernel.exe` file and is launched by the Windows Loader after the hypervisor has already been successfully started. As shown in Figure 9-31, the Secure Kernel is a minimal OS that works strictly with the normal kernel, which resides in VTL 0. As for any normal OS, the Secure Kernel runs in CPL 0 (also known as ring 0 or kernel mode) of VTL 1 and provides services (the majority of them through system calls) to the Isolated User Mode (IUM), which lives in CPL 3 (also known as ring 3 or user mode) of VTL 1. The Secure Kernel has been designed to be as small as possible with the goal to reduce the external attack surface. It's not extensible with external device drivers like the normal kernel. The only kernel modules that extend their functionality are loaded by the Windows Loader before VSM is launched and are imported from `securekernel.exe`:

- **Skci.dll** Implements the Hypervisor Enforced Code Integrity part of the Secure Kernel
- **Cng.sys** Provides the cryptographic engine to the Secure Kernel
- **Vmsvcext.dll** Provides support for the attestation of the Secure Kernel components in Intel TXT (Trusted Boot) environments (more information about Trusted Boot is available in Chapter 12)

While the Secure Kernel is not extensible, the Isolated User Mode includes specialized processes called *Trustlets*. Trustlets are isolated among each other and have specialized digital signature requirements. They can communicate with the Secure Kernel through syscalls and with the normal world through Mailslots and ALPC. Isolated User Mode is discussed later in this chapter.

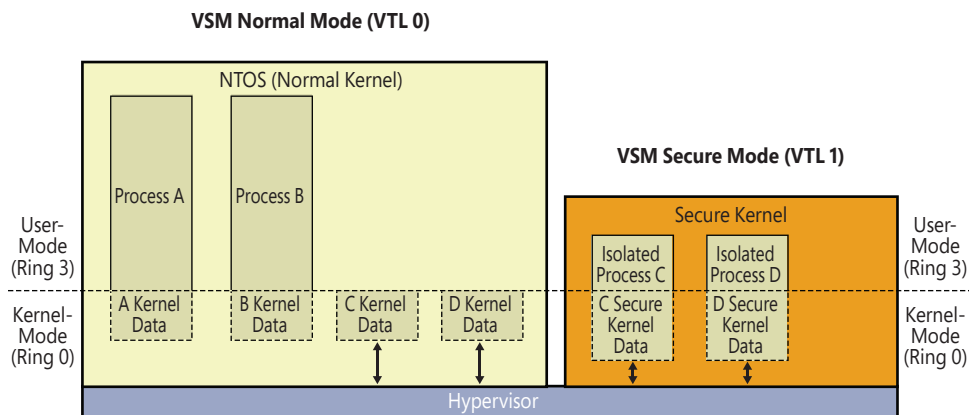

FIGURE 9-31 Virtual Secure Mode Architecture scheme, built on top of the hypervisor.

Virtual interrupts

When the hypervisor configures the underlying virtual partitions, it requires that the physical processors produce a VMEXIT every time an external interrupt is raised by the CPU physical APIC (Advanced Programmable Interrupt Controller). The hardware's virtual machine extensions allow the hypervisor to inject virtual interrupts to the guest partitions (more details are in the Intel, AMD, and ARM user

manuals). Thanks to these two facts, the hypervisor implements the concept of a Synthetic Interrupt Controller (SynIC). A SynIC can manage two kind of interrupts. Virtual interrupts are interrupts delivered to a guest partition's virtual APIC. A virtual interrupt can represent and be associated with a physical hardware interrupt, which is generated by the real hardware. Otherwise, a virtual interrupt can represent a synthetic interrupt, which is generated by the hypervisor itself in response to certain kinds of events. The SynIC can map physical interrupts to virtual ones. A VTL has a SynIC associated with each virtual processor in which the VTL runs. At the time of this writing, the hypervisor has been designed to support 16 different synthetic interrupt vectors (only 2 are actually in use, though).

When the system starts (phase 1 of the NT kernel's initialization) the ACPI driver maps each interrupt to the correct vector using services provided by the HAL. The NT HAL is enlightened and knows whether it's running under VSM. In that case, it calls into the hypervisor for mapping each physical interrupt to its own VTL. Even the Secure Kernel could do the same. At the time of this writing, though, no physical interrupts are associated with the Secure Kernel (this can change in the future; the hypervisor already supports this feature). The Secure Kernel instead asks the hypervisor to receive only the following virtual interrupts: Secure Timers, Virtual Interrupt Notification Assist (VINA), and Secure Intercepts.



Note It's important to understand that the hypervisor requires the underlying hardware to produce a VMEXIT while managing interrupts that are *only* of external types. Exceptions are still managed in the same VTL the processor is executing at (no VMEXIT is generated). If an instruction causes an exception, the latter is still managed by the structured exception handling (SEH) code located in the current VTL.

To understand the three kinds of virtual interrupts, we must first introduce how interrupts are managed by the hypervisor.

In the hypervisor, each VTL has been designed to securely receive interrupts from devices associated with its own VTL, to have a secure timer facility which can't be interfered with by less secure VTLs, and to be able to prevent interrupts directed to lower VTLs while executing code at a higher VTL. Furthermore, a VTL should be able to send IPI interrupts to other processors. This design produces the following scenarios:

- When running at a particular VTL, reception of interrupts targeted at the current VTL results in standard interrupt handling (as determined by the virtual APIC controller of the VP).
- When an interrupt is received that is targeted at a higher VTL, receipt of the interrupt results in a switch to the higher VTL to which the interrupt is targeted if the IRQL value for the higher VTL would allow the interrupt to be presented. If the IRQL value of the higher VTL does not allow the interrupt to be delivered, the interrupt is queued without switching the current VTL. This behavior allows a higher VTL to selectively mask interrupts when returning to a lower VTL. This could be useful if the higher VTL is running an interrupt service routine and needs to return to a lower VTL for assistance in processing the interrupt.
- When an interrupt is received that is targeted at a lower VTL than the current executing VTL of a virtual processor, the interrupt is queued for future delivery to the lower VTL. An interrupt targeted at a lower VTL will *never* preempt execution of the current VTL. Instead, the interrupt is presented when the virtual processor next transitions to the targeted VTL.

Preventing interrupts directed to lower VTLs is not always a great solution. In many cases, it could lead to the slowing down of the normal OS execution (especially in mission-critical or game environments). To better manage these conditions, the VINA has been introduced. As part of its normal event dispatch loop, the hypervisor checks whether there are pending interrupts queued to a lower VTL. If so, the hypervisor injects a VINA interrupt to the current executing VTL. The Secure Kernel has a handler registered for the VINA vector in its virtual IDT. The handler (*ShvVinaHandler* function) executes a normal call (*NORMALKERNEL_VINA*) to VTL 0 (Normal and Secure Calls are discussed later in this chapter). This call forces the hypervisor to switch to the normal kernel (VTL 0). As long as the VTL is switched, all the queued interrupts will be correctly dispatched. The normal kernel will reenter VTL 1 by emitting a *SECUREKERNEL_RESUMETHREAD* Secure Call.

Secure IRQLs

The VINA handler will not always be executed in VTL 1. Similar to the NT kernel, this depends on the actual IRQL the code is executing into. The current executing code's IRQL masks all the interrupts that are associated with an IRQL that's less than or equal to it. The mapping between an interrupt vector and the IRQL is maintained by the Task Priority Register (TPR) of the virtual APIC, like in case of real physical APICs (consult the Intel Architecture Manual for more information). As shown in Figure 9-32, the Secure Kernel supports different levels of IRQL compared to the normal kernel. Those IRQL are called Secure IRQL.

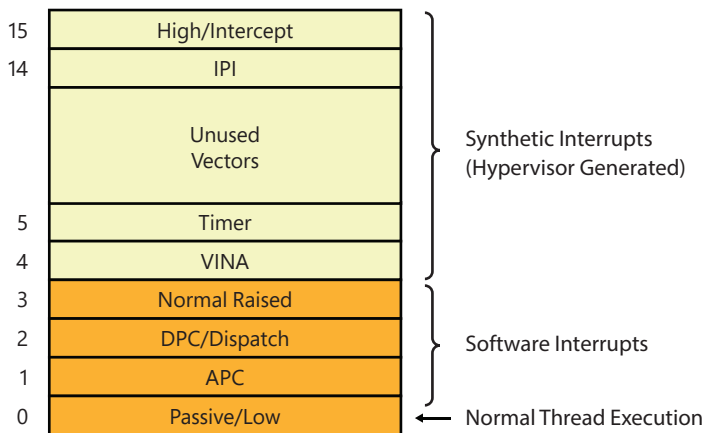

FIGURE 9-32 Secure Kernel interrupts request levels (IRQL).

The first three secure IRQL are managed by the Secure Kernel in a way similar to the normal world. Normal APCs and DPCs (targeting VTL 0) still can't preempt code executing in VTL 1 through the hypervisor, but the VINA interrupt is still delivered to the Secure Kernel (the operating system manages the three software interrupts by writing in the target processor's APIC Task-Priority Register, an operation that causes a VMEXIT to the hypervisor. For more information about the APIC TPR, see the Intel, AMD, or ARM manuals). This means that if a normal-mode DPC is targeted at a processor while it is executing VTL 1 code (at a compatible secure IRQL, which should be less than Dispatch), the VINA interrupt will be delivered and will switch the execution context to VTL 0. As a matter of fact, this executes the DPC in the normal world and raises for a while the normal kernel's IRQL to dispatch level. When the DPC queue is drained, the normal kernel's IRQL drops. Execution flow returns to the Secure Kernel thanks to

the VSM communication loop code that is located in the *VslpEnterlumSecureMode* routine. The loop processes each normal call originated from the Secure Kernel.

The Secure Kernel maps the first three secure IRQLs to the same IRQL of the normal world. When a Secure call is made from code executing at a particular IRQL (still less or equal to dispatch) in the normal world, the Secure Kernel switches its own secure IRQL to the same level. Vice versa, when the Secure Kernel executes a normal call to enter the NT kernel, it switches the normal kernel's IRQL to the same level as its own. This works only for the first three levels.

The normal raised level is used when the NT kernel enters the secure world at an IRQL higher than the *DPC* level. In those cases, the Secure Kernel maps all of the normal-world IRQLs, which are above *DPC*, to its normal raised secure level. Secure Kernel code executing at this level can't receive any VINA for any kind of software IRQLs in the normal kernel (but it can still receive a VINA for hardware interrupts). Every time the NT kernel enters the secure world at a normal IRQL above *DPC*, the Secure Kernel raises its secure IRQL to normal raised.

Secure IRQLs equal to or higher than VINA can never be preempted by any code in the normal world. This explains why the Secure Kernel supports the concept of secure, nonpreemptable timers and Secure Intercepts. Secure timers are generated from the hypervisor's clock interrupt service routine (ISR). This ISR, before injecting a synthetic clock interrupt to the NT kernel, checks whether there are one or more secure timers that are expired. If so, it injects a synthetic secure timer interrupt to VTL 1. Then it proceeds to forward the clock tick interrupt to the normal VTL.

Secure intercepts

There are cases where the Secure Kernel may need to prevent the NT kernel, which executes at a lower VTL, from accessing certain critical system resources. For example, writes to some processor's MSRs could potentially be used to mount an attack that would disable the hypervisor or subvert some of its protections. VSM provides a mechanism to allow a higher VTL to lock down critical system resources and prevent access to them by lower VTLs. The mechanism is called *secure intercepts*.

Secure intercepts are implemented in the Secure Kernel by registering a synthetic interrupt, which is provided by the hypervisor (remapped in the Secure Kernel to vector 0xF0). The hypervisor, when certain events cause a VMEXIT, injects a synthetic interrupt to the higher VTL on the virtual processor that triggered the intercept. At the time of this writing, the Secure Kernel registers with the hypervisor for the following types of intercepted events:

- Write to some vital processor's MSRs (*Star*, *Lstar*, *Cstar*, *Efer*, *Sysenter*, *la32Misc*, and *APIC base* on AMD64 architectures) and special registers (*GDT*, *IDT*, *LDT*)
- Write to certain control registers (*CR0*, *CR4*, and *XCR0*)
- Write to some I/O ports (ports *0xCF8* and *0xCFC* are good examples; the intercept manages the reconfiguration of PCI devices)
- Invalid access to protected guest physical memory

When VTL 0 software causes an intercept that will be raised in VTL 1, the Secure Kernel needs to recognize the intercept type from its interrupt service routine. For this purpose, the Secure Kernel uses the message queue allocated by the SynIC for the “Intercept” synthetic interrupt source (see the “Interpartition communication” section previously in this section for more details about the SynIC and SINT). The Secure Kernel is able to discover and map the physical memory page by checking the SIMP synthetic MSR, which is virtualized by the hypervisor. The mapping of the physical page is executed at the Secure Kernel initialization time in VTL 1. The Secure Kernel’s startup is described later in this chapter.

Intercepts are used extensively by HyperGuard with the goal to protect sensitive parts of the normal NT kernel. If a malicious rootkit installed in the NT kernel tries to modify the system by writing a particular value to a protected register (for example to the syscall handlers, CSTAR and LSTAR, or model-specific registers), the Secure Kernel intercept handler (*ShvIplInterceptHandler*) filters the new register’s value, and, if it discovers that the value is not acceptable, it injects a General Protection Fault (GPF) nonmaskable exception to the NT kernel in VTL 0. This causes an immediate bugcheck resulting in the system being stopped. If the value is acceptable, the Secure Kernel writes the new value of the register using the hypervisor through the *HvSetVpRegisters* hypercall (in this case, the Secure Kernel is proxying the access to the register).

Control over hypercalls

The last intercept type that the Secure Kernel registers with the hypervisor is the hypercall intercept. The hypercall intercept’s handler checks that the hypercall emitted by the VTL 0 code to the hypervisor is legit and is originated from the operating system itself, and not through some external modules. Every time in any VTL a hypercall is emitted, it causes a VMEXIT in the hypervisor (by design). Hypercalls are the base service used by kernel components of each VTL to request services between each other (and to the hypervisor itself). The hypervisor injects a synthetic intercept interrupt to the higher VTL only for hypercalls used to request services directly to the hypervisor, skipping all the hypercalls used for secure and normal calls to and from the Secure Kernel.

If the hypercall is not recognized as valid, it won’t be executed: the Secure Kernel in this case updates the lower VTL’s registers with the goal to signal the hypercall error. The system is not crashed (although this behavior can change in the future); the calling code can decide how to manage the error.

VSM system calls

As we have introduced in the previous sections, VSM uses hypercalls to request services to and from the Secure Kernel. Hypercalls were originally designed as a way to request services to the hypervisor, but in VSM the model has been extended to support new types of system calls:

- Secure calls are emitted by the normal NT kernel in VTL 0 to require services to the Secure Kernel.
- Normal calls are requested by the Secure Kernel in VTL 1 when it needs services provided by the NT kernel, which runs in VTL 0. Furthermore, some of them are used by secure processes (trustlets) running in Isolated User Mode (IUM) to request services from the Secure Kernel or the normal NT kernel.

These kinds of system calls are implemented in the hypervisor, the Secure Kernel, and the normal NT kernel. The hypervisor defines two hypercalls for switching between different VTLs: *HvVtlCall* and *HvVtlReturn*. The Secure Kernel and NT kernel define the dispatch loop used for dispatching Secure and Normal Calls.

Furthermore, the Secure Kernel implements another type of system call: secure system calls. They provide services only to secure processes (trustlets), which run in IUM. These system calls are not exposed to the normal NT kernel. The hypervisor is not involved at all while processing secure system calls.

Virtual processor state

Before delving into the Secure and Normal calls architecture, it is necessary to analyze how the virtual processor manages the VTL transition. Secure VTLs always operate in long mode (which is the execution model of AMD64 processors where the CPU accesses 64-bit-only instructions and registers), with paging enabled. Any other execution model is not supported. This simplifies launch and management of secure VTLs and also provides an extra level of protection for code running in secure mode. (Some other important implications are discussed later in the chapter.)

For efficiency, a virtual processor has some registers that are shared between VTLs and some other registers that are private to each VTL. The state of the shared registers does not change when switching between VTLs. This allows a quick passing of a small amount of information between VTLs, and it also reduces the context switch overhead when switching between VTLs. Each VTL has its own instance of private registers, which could only be accessed by that VTL. The hypervisor handles saving and restoring the contents of private registers when switching between VTLs. Thus, when entering a VTL on a virtual processor, the state of the private registers contains the same values as when the virtual processor last ran that VTL.

Most of a virtual processor's register state is shared between VTLs. Specifically, general purpose registers, vector registers, and floating-point registers are shared between all VTLs with a few exceptions, such as the RIP and the RSP registers. Private registers include some control registers, some architectural registers, and hypervisor virtual MSRs. The secure intercept mechanism (see the previous section for details) is used to allow the Secure environment to control which MSR can be accessed by the normal mode environment. Table 9-3 summarizes which registers are shared between VTLs and which are private to each VTL.

TABLE 9-3 Virtual processor per-VTL register states

Type	General Registers	MSRs
Shared	Rax, Rbx, Rcx, Rdx, Rsi, Rdi, Rbp CR2 R8 – R15 DR0 – DR5 X87 floating point state XMM registers AVX registers XCRO (XFEM) DR6 (processor-dependent)	HV_X64_MSR_TSC_FREQUENCY HV_X64_MSR_VP_INDEX HV_X64_MSR_VP_RUNTIME HV_X64_MSR_RESET HV_X64_MSR_TIME_REF_COUNT HV_X64_MSR_GUEST_IDLE HV_X64_MSR_DEBUG_DEVICE_OPTIONS HV_X64_MSR_BELOW_1MB_PAGE HV_X64_MSR_STATS_PARTITION_RETAIL_PAGE HV_X64_MSR_STATS_VP_RETAIL_PAGE MTRR's and PAT MCG_CAP MCG_STATUS
Private	RIP, RSP RFLAGS CR0, CR3, CR4 DR7 IDTR, GDTR CS, DS, ES, FS, GS, SS, TR, LDTR TSC DR6 (processor-dependent)	SYSENTER_CS, SYSENTER_ESP, SYSENTER_EIP, STAR, LSTAR, CSTAR, SFMASK, EFER, KERNEL_GSBASE, FS.BASE, GS.BASE HV_X64_MSR_HYPERCALL HV_X64_MSR_GUEST_OS_ID HV_X64_MSR_REFERENCE_TSC HV_X64_MSR_APIC_FREQUENCY HV_X64_MSR_EOI HV_X64_MSR_ICR HV_X64_MSR_TPR HV_X64_MSR_APIC_ASSIST_PAGE HV_X64_MSR_NPIEP_CONFIG HV_X64_MSR_SIRBP HV_X64_MSR_SCONTROL HV_X64_MSR_SVERSION HV_X64_MSR_SIEFP HV_X64_MSR_SIMP HV_X64_MSR_EOM HV_X64_MSR_SINT0 – HV_X64_MSR_SINT15 HV_X64_MSR_STIMER0_CONFIG – HV_X64_MSR_STIMER3_CONFIG HV_X64_MSR_STIMER0_COUNT – HV_X64_MSR_STIMER3_COUNT Local APIC registers (including CR8/TPR)

Secure calls

When the NT kernel needs services provided by the Secure Kernel, it uses a special function, *VslpEnterlumSecureMode*. The routine accepts a 104-byte data structure (called *SKCALL*), which is used to describe the kind of operation (invoke service, flush TB, resume thread, or call enclave), the secure call number, and a maximum of twelve 8-byte parameters. The function raises the processor's IRQL, if necessary, and determines the value of the Secure Thread cookie. This value communicates to the Secure Kernel which secure thread will process the request. It then (re)starts the secure calls dispatch loop. The executability state of each VTL is a state machine that depends on the other VTL.

The loop described by the *VslpEnterlumSecureMode* function manages all the operations shown on the left side of Figure 9-33 in VTL 0 (except the case of Secure Interrupts). The NT kernel can decide to enter the Secure Kernel, and the Secure Kernel can decide to enter the normal NT kernel. The loop starts by entering the Secure Kernel through the *HvSwitchToVsmVtl1* routine (specifying the operation requested by the caller). The latter function, which returns only if the Secure Kernel requests a VTL switch, saves all the shared registers and copies the entire *SKCALL* data structure in some well-defined CPU registers: RBX and the SSE registers XMM10 through XMM15. Finally, it emits an *HvVtlCall* hypercall to the hypervisor. The hypervisor switches to the target VTL (by loading the saved per-VTL VMCS) and

writes a VTL secure call entry reason to the VTL control page. Indeed, to be able to determine why a secure VTL was entered, the hypervisor maintains an informational memory page that is shared by each secure VTL. This page is used for bidirectional communication between the hypervisor and the code running in a secure VTL on a virtual processor.

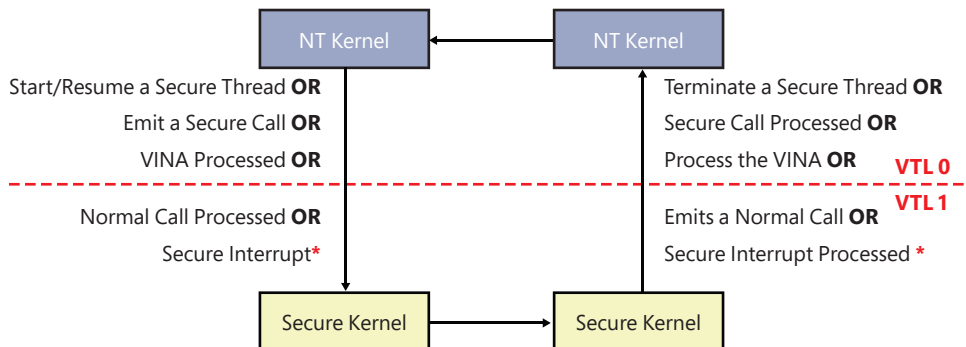

FIGURE 9-33 The VSM dispatch loop.

The virtual processor restarts the execution in VTL 1 context, in the *SkCallNormalMode* function of the Secure Kernel. The code reads the VTL entry reason; if it's not a Secure Interrupt, it loads the current processor SKPRCB (Secure Kernel processor control block), selects a thread on which to run (starting from the secure thread cookie), and copies the content of the *SKCALL* data structure from the CPU shared registers to a memory buffer. Finally, it calls the *lumInvokeSecureService* dispatcher routine, which will process the requested secure call, by dispatching the call to the correct function (and implements part of the dispatch loop in VTL 1).

An important concept to understand is that the Secure Kernel can map and access VTL 0 memory, so there's no need to marshal and copy any eventual data structure, pointed by one or more parameters, to the VTL 1 memory. This concept won't apply to a normal call, as we will discuss in the next section.

As we have seen in the previous section, Secure Interrupts (and intercepts) are dispatched by the hypervisor, which preempts any code executing in VTL 0. In this case, when the VTL 1 code starts the execution, it dispatches the interrupt to the right ISR. After the ISR finishes, the Secure Kernel immediately emits a *HvVtlReturn* hypercall. As a result, the code in VTL 0 restarts the execution at the point in which it has been previously interrupted, which is not located in the secure calls dispatch loop. Therefore, Secure Interrupts are not part of the dispatch loop even if they still produce a VTL switch.

Normal calls

Normal calls are managed similarly to the secure calls (with an analogous dispatch loop located in VTL 1, called *normal calls loop*), but with some important differences:

- All the shared VTL registers are securely cleaned up by the Secure Kernel before emitting the *HvVtlReturn* to the hypervisor for switching the VTL. This prevents leaking any kind of secure data to normal mode.

- The normal NT kernel can't read secure VTL 1 memory. For correctly passing the syscall parameters and data structures needed for the normal call, a memory buffer that both the Secure Kernel and the normal kernel can share is required. The Secure Kernel allocates this shared buffer using the *ALLOCATE_VM* normal call (which does not require passing any pointer as a parameter). The latter is dispatched to the *MmAllocateVirtualMemory* function in the NT normal kernel. The allocated memory is remapped in the Secure Kernel at the same virtual address and has become part of the Secure process's shared memory pool.
- As we will discuss later in the chapter, the Isolated User Mode (IUM) was originally designed to be able to execute special Win32 executables, which should have been capable of running indifferently in the normal world or in the secure world. The standard unmodified Ntdll.dll and KernelBase.dll libraries are mapped even in IUM. This fact has the important consequence of requiring almost all the native NT APIs (which Kernel32.dll and many other user mode libraries depend on) to be proxied by the Secure Kernel.

To correctly deal with the described problems, the Secure Kernel includes a marshaler, which identifies and correctly copies the data structures pointed by the parameters of an NT API in the shared buffer. The marshaler is also able to determine the size of the shared buffer, which will be allocated from the secure process memory pool. The Secure Kernel defines three types of normal calls:

- **A disabled normal call** is not implemented in the Secure Kernel and, if called from IUM, it simply fails with a *STATUS_INVALID_SYSTEM_SERVICE* exit code. This kind of call can't be called directly by the Secure Kernel itself.
- **An enabled normal call** is implemented only in the NT kernel and is callable from IUM in its original *Nt* or *Zw* version (through Ntdll.dll). Even the Secure Kernel can request an enabled normal call—but only through a little stub code that loads the normal call number—set the highest bit in the number, and call the normal call dispatcher (*IumGenericSyscall* routine). The highest bit identifies the normal call as required by the Secure Kernel itself and not by the Ntdll.dll module loaded in IUM.
- **A special normal call** is implemented partially or completely in Secure Kernel (VTL 1), which can filter the original function's results or entirely redesign its code.

Enabled and special normal calls can be marked as *KernelOnly*. In the latter case, the normal call can be requested only from the Secure Kernel itself (and not from secure processes). We've already provided the list of enabled and special normal calls (which are callable from software running in VSM) in Chapter 3 of Part 1, in the section named "Trustlet-accessible system calls."

Figure 9-34 shows an example of a special normal call. In the example, the Lsalso trustlet has called the *NtQueryInformationProcess* native API to request information of a particular process. The Ntdll.dll mapped in IUM prepares the syscall number and executes a SYSCALL instruction, which transfers the execution flow to the *KiSystemServiceStart* global system call dispatcher, residing in the Secure Kernel (VTL 1). The global system call dispatcher recognizes that the system call number belongs to a normal call and uses the number to access the *IumSyscallDispatchTable* array, which represents the normal calls dispatch table.

The normal calls dispatch table contains an array of compacted entries, which are generated in phase 0 of the Secure Kernel startup (discussed later in this chapter). Each entry contains an offset to a target function (calculated relative to the table itself) and the number of its arguments (with some flags). All the offsets in the table are initially calculated to point to the normal call dispatcher routine (*lumGenericSyscall*). After the first initialization cycle, the Secure Kernel startup routine patches each entry that represents a special call. The new offset is pointed to the part of code that implements the normal call in the Secure Kernel.

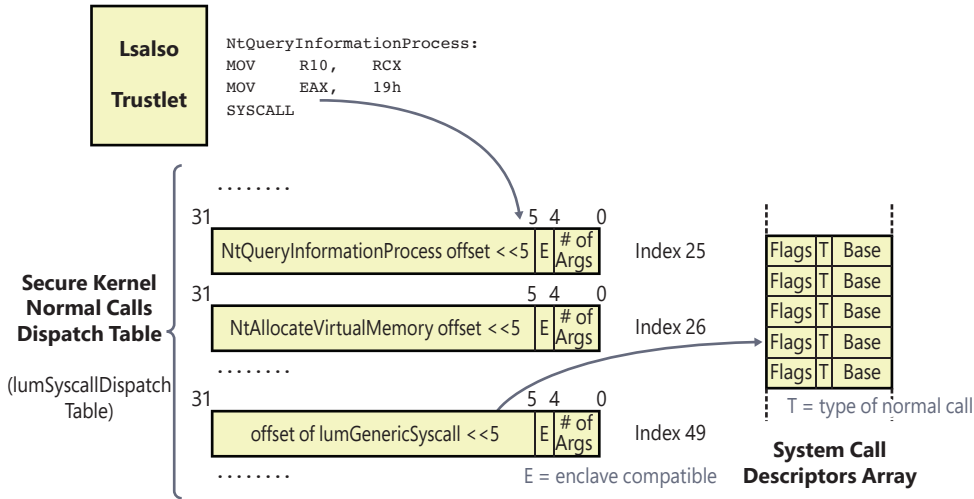

FIGURE 9-34 A trustlet performing a special normal call to the *NtQueryInformationProcess* API.

As a result, in Figure 9-34, the global system calls dispatcher transfers execution to the *NtQueryInformationProcess* function's part implemented in the Secure Kernel. The latter checks whether the requested information class is one of the small subsets exposed to the Secure Kernel and, if so, uses a small stub code to call the normal call dispatcher routine (*lumGenericSyscall*).

Figure 9-35 shows the syscall selector number for the *NtQueryInformationProcess* API. Note that the stub sets the highest bit (N bit) of the syscall number to indicate that the normal call is requested by the Secure Kernel. The normal call dispatcher checks the parameters and calls the marshaler, which is able to marshal each argument and copy it in the right offset of the shared buffer. There is another bit in the selector that further differentiates between a normal call or a secure system call, which is discussed later in this chapter.

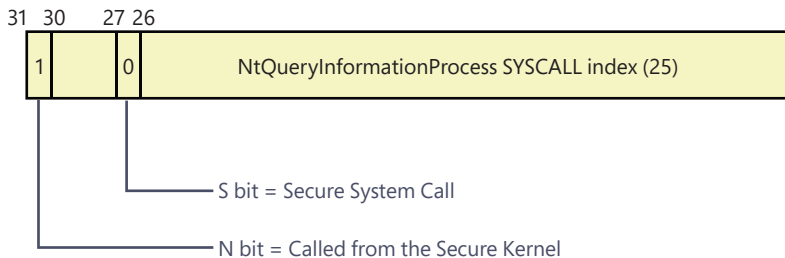

FIGURE 9-35 The Syscall selector number of the Secure Kernel.

The marshaler works thanks to two important arrays that describe each normal call: the descriptors array (shown in the right side of Figure 9-34) and the arguments descriptors array. From these arrays, the marshaler can fetch all the information that it needs: normal call type, marshalling function index, argument type, size, and type of data pointed to (if the argument is a pointer).

After the shared buffer has been correctly filled by the marshaler, the Secure Kernel compiles the *SKCALL* data structure and enters the normal call dispatcher loop (*SkCallNormalMode*). This part of the loop saves and clears all the shared virtual CPU registers, disables interrupts, and moves the thread context to the PRCB thread (more about thread scheduling later in the chapter). It then copies the content of the *SKCALL* data structure in some shared register. As a final stage, it calls the hypervisor through the *HvVtlReturn* hypercall.

Then the code execution resumes in the secure call dispatch loop in VTL 0. If there are some pending interrupts in the queue, they are processed as normal (only if the IRQL allows it). The loop recognizes the normal call operation request and calls the *NtQueryInformationProcess* function implemented in VTL 0. After the latter function finished its processing, the loop restarts and reenters the Secure Kernel again (as for Secure Calls), still through the *HvSwitchToVsmVtl1* routine, but with a different operation request: Resume thread. This, as the name implies, allows the Secure Kernel to switch to the original secure thread and to continue the execution that has been preempted for executing the normal call.

The implementation of enabled normal calls is the same except for the fact that those calls have their entries in the normal calls dispatch table, which point directly to the normal call dispatcher routine, *IumGenericSyscall*. In this way, the code will transfer directly to the handler, skipping any API implementation code in the Secure Kernel.

Secure system calls

The last type of system calls available in the Secure Kernel is similar to standard system calls provided by the NT kernel to VTL 0 user mode software. The secure system calls are used for providing services only to the secure processes (trustlets). VTL 0 software can't emit secure system calls in any way. As we will discuss in the "Isolated User Mode" section later in this chapter, every trustlet maps the IUM Native Layer Dll (*IumDll.dll*) in its address space. *IumDll.dll* has the same job as its counterpart in VTL 0, *Ntdll.dll*: implement the native syscall stub functions for user mode application. The stub copies the syscall number in a register and emits the *SYSCALL* instruction (the instruction uses different opcodes depending on the platform).

Secure system calls numbers always have the twenty-eighth bit set to 1 (on AMD64 architectures, whereas ARM64 uses the sixteenth bit). In this way, the global system call dispatcher (*KiSystemServiceStart*) recognizes that the syscall number belongs to a secure system call (and not a normal call) and switches to the *SkiSecureServiceTable*, which represents the secure system calls dispatch table. As in the case of normal calls, the global dispatcher verifies that the call number is in the limit, allocates stack space for the arguments (if needed), calculates the system call final address, and transfers the code execution to it.

Overall, the code execution remains in VTL 1, but the current privilege level of the virtual processor raises from 3 (user mode) to 0 (kernel mode). The dispatch table for secure system calls is compacted—similarly to the normal calls dispatch table—at phase 0 of the Secure Kernel startup. However, entries in this table are all valid and point to functions implemented in the Secure Kernel.

Secure threads and scheduling

As we will describe in the “Isolated User Mode” section, the execution units in VSM are the secure threads, which live in the address space described by a secure process. Secure threads can be kernel mode or user mode threads. VSM maintains a strict correspondence between each user mode secure thread and normal thread living in VTL 0.

Indeed, the Secure Kernel thread scheduling depends completely on the normal NT kernel; the Secure Kernel doesn’t include a proprietary scheduler (by design, the Secure Kernel attack surface needs to be small). In Chapter 3 of Part 1, we described how the NT kernel creates a process and the relative initial thread. In the section that describes Stage 4, “Creating the initial thread and its stack and context,” we explain that a thread creation is performed in two parts:

- The executive thread object is created; its kernel and user stack are allocated. The *KelInitThread* routine is called for setting up the initial thread context for user mode threads. *KiStartUserThread* is the first routine that will be executed in the context of the new thread, which will lower the thread’s IRQL and call *PspUserThreadStartup*.
- The execution control is then returned to *NtCreateUserProcess*, which, at a later stage, calls *PspInsertThread* to complete the initialization of the thread and insert it into the object manager namespace.

As a part of its work, when *PspInsertThread* detects that the thread belongs to a secure process, it calls *VsICreateSecureThread*, which, as the name implies, uses the Create Thread secure service call to ask to the Secure Kernel to create an associated secure thread. The Secure Kernel verifies the parameters and gets the process’s secure image data structure (more details about this later in this chapter). It then allocates the secure thread object and its TEB, creates the initial thread context (the first routine that will run is *SkpUserThreadStartup*), and finally makes the thread schedulable. Furthermore, the secure service handler in VTL 1, after marking the thread as ready to run, returns a specific thread cookie, which is stored in the ETHREAD data structure.

The new secure thread still starts in VTL 0. As described in the “Stage 7” section of Chapter 3 of Part 1, *PspUserThreadStartup* performs the final initialization of the user thread in the new context. In case it determines that the thread’s owning process is a trustlet, *PspUserThreadStartup* calls the *VsIStartSecureThread* function, which invokes the secure calls dispatch loop through the *VsIspEnterlumSecureMode* routine in VTL 0 (passing the secure thread cookie returned by the Create Thread secure service handler). The first operation that the dispatch loop requests to the Secure Kernel is to resume the execution of the secure thread (still through the *HvVtlCall* hypercall).

The Secure Kernel, before the switch to VTL 0, was executing code in the normal call dispatcher loop (*SkCallNormalMode*). The hypercall executed by the normal kernel restarts the execution in the same loop routine. The VTL 1 dispatcher loop recognizes the new thread resume request; it switches its execution context to the new secure thread, attaches to its address spaces, and makes it runnable. As part of the context switching, a new stack is selected (which has been previously initialized by the Create Thread secure call). The latter contains the address of the first secure thread system function, *SkpUserThreadStartup*, which, similarly to the case of normal NT threads, sets up the initial thunk context to run the image-loader initialization routine (*LdrInitializeThunk* in Ntdll.dll).

After it has started, the new secure thread can return to normal mode for two main reasons: it emits a normal call, which needs to be processed in VTL 0, or the VINA interrupts preempt the code execution. Even though the two cases are processed in a slightly different way, they both result in executing the normal call dispatcher loop (*SkCallNormalMode*).

As previously discussed in Part 1, Chapter 4, “Threads,” the NT scheduler works thanks to the processor clock, which generates an interrupt every time the system clock fires (usually every 15.6 milliseconds). The clock interrupt service routine updates the processor times and calculates whether the thread quantum expires. The interrupt is targeted to VTL 0, so, when the virtual processor is executing code in VTL 1, the hypervisor injects a VINA interrupt to the Secure Kernel, as shown in Figure 9-36. The VINA interrupt preempts the current executing code, lowers the IRQL to the previous preempted code’s IRQL value, and emits the VINA normal call for entering VTL 0.

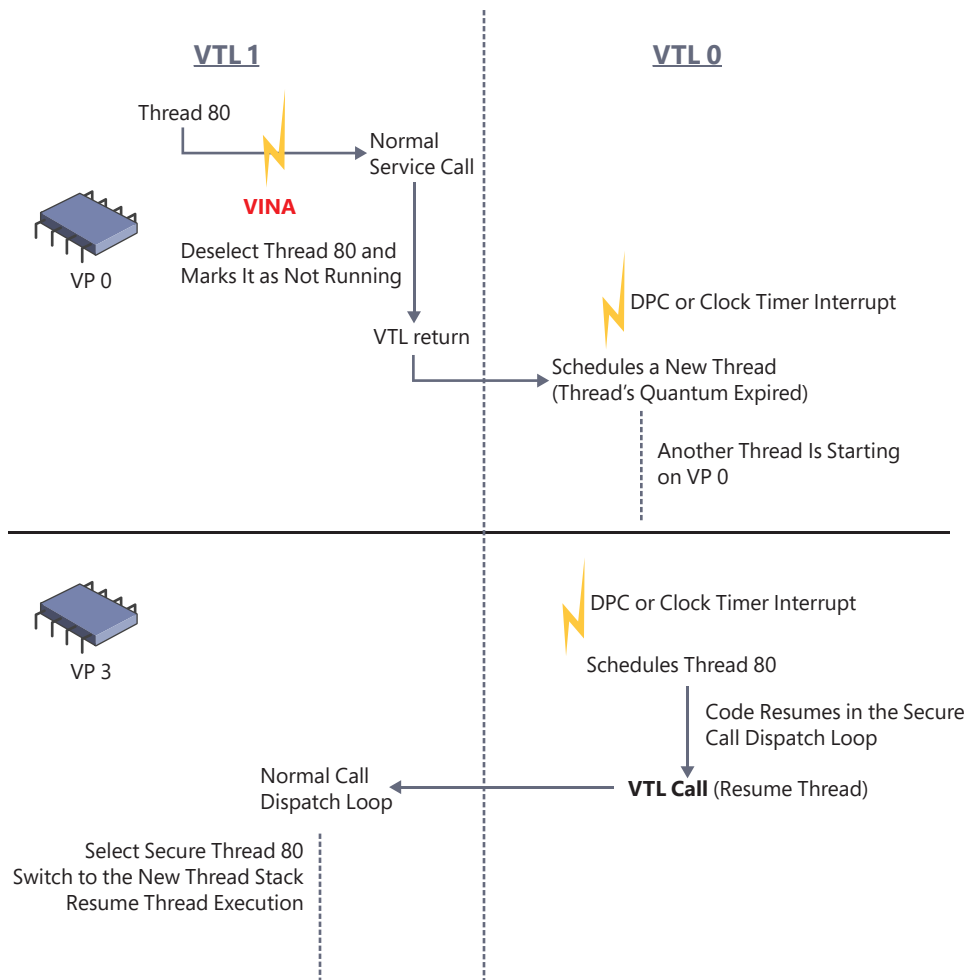

FIGURE 9-36 Secure threads scheduling scheme.

As the standard process of normal call dispatching, before the Secure Kernel emits the *HvVtlReturn* hypercall, it deselects the current execution thread from the virtual processor's PRCB. This is important: The VP in VTL 1 is not tied to any thread context anymore and, on the next loop cycle, the Secure Kernel can switch to a different thread or decide to reschedule the execution of the current one.

After the VTL switch, the NT kernel resumes the execution in the secure calls dispatch loop and still in the context of the new thread. Before it has any chance to execute any code, the code is preempted by the clock interrupt service routine, which can calculate the new quantum value and, if the latter has expired, switch the execution of another thread. When a context switch occurs, and another thread enters VTL 1, the normal call dispatch loop schedules a different secure thread depending on the value of the secure thread cookie:

- A secure thread from the secure thread pool if the normal NT kernel has entered VTL 1 for dispatching a secure call (in this case, the secure thread cookie is 0).
- The newly created secure thread if the thread has been rescheduled for execution (the secure thread cookie is a valid value). As shown in Figure 9-36, the new thread can be also rescheduled by another virtual processor (VP 3 in the example).

With the described schema, all the scheduling decisions are performed only in VTL 0. The secure call loop and normal call loops cooperate to correctly switch the secure thread context in VTL 1. All the secure threads have an associated a thread in the normal kernel. The opposite is not true, though; if a normal thread in VTL 0 decides to emit a secure call, the Secure Kernel dispatches the request by using an arbitrary thread context from a thread pool.

The Hypervisor Enforced Code Integrity

Hypervisor Enforced Code Integrity (HVCI) is the feature that powers Device Guard and provides the *W^X* (pronounced *double-you xor ex*) characteristic of the VTL 0 kernel memory. The NT kernel can't map and executes any kind of executable memory in kernel mode without the aid of the Secure Kernel. The Secure Kernel allows only proper digitally signed drivers to run in the machine's kernel. As we discuss in the next section, the Secure Kernel keeps track of every virtual page allocated in the normal NT kernel; memory pages marked as executable in the NT kernel are considered *privileged pages*. Only the Secure Kernel can write to them after the SKCI module has correctly verified their content.

You can read more about HVCI in Chapter 7 of Part 1, in the "Device Guard" and "Credential Guard" sections.

UEFI runtime virtualization

Another service provided by the Secure Kernel (when HVCI is enabled) is the ability to virtualize and protect the UEFI runtime services. As we discuss in Chapter 12, the UEFI firmware services are mainly implemented by using a big table of function pointers. Part of the table will be deleted from memory after the OS takes control and calls the *ExitBootServices* function, but another part of the table, which represents the Runtime services, will remain mapped even after the OS has already taken full control of the machine. Indeed, this is necessary because sometimes the OS needs to interact with the UEFI configuration and services.

Every hardware vendor implements its own UEFI firmware. With HVCI, the firmware should cooperate to provide the nonwritable state of each of its executable memory pages (no firmware page can be mapped in VTL 0 with read, write, and execute state). The memory range in which the UEFI firmware resides is described by multiple *MEMORY_DESCRIPTOR* data structures located in the EFI memory map. The Windows Loader parses this data with the goal to properly protect the UEFI firmware's memory. Unfortunately, in the original implementation of UEFI, the code and data were stored mixed in a single section (or multiple sections) and were described by relative memory descriptors. Furthermore, some device drivers read or write configuration data directly from the UEFI's memory regions. This clearly was not compatible with HVCI.

For overcoming this problem, the Secure Kernel employs the following two strategies:

- New versions of the UEFI firmware (which adhere to UEFI 2.6 and higher specifications) maintain a new configuration table (linked in the boot services table), called memory attribute table (MAT). The MAT defines fine-grained sections of the UEFI Memory region, which are subsections of the memory descriptors defined by the EFI memory map. Each section never has both the executable and writable protection attribute.
- For old firmware, the Secure Kernel maps in VTL 0 the entire UEFI firmware region's physical memory with a read-only access right.

In the first strategy, at boot time, the Windows Loader merges the information found both in the EFI memory map and in the MAT, creating an array of memory descriptors that precisely describe the entire firmware region. It then copies them in a reserved buffer located in VTL 1 (used in the hibernation path) and verifies that each firmware's section doesn't violate the W^X assumption. If so, when the Secure Kernel starts, it applies a proper SLAT protection for every page that belongs to the underlying UEFI firmware region. The physical pages are protected by the SLAT, but their virtual address space in VTL 0 is still entirely marked as RWX. Keeping the virtual memory's RWX protection is important because the Secure Kernel must support resume-from-hibernation in a scenario where the protection applied in the MAT entries can change. Furthermore, this maintains the compatibility with older drivers, which read or write directly from the UEFI memory region, assuming that the write is performed in the correct sections. (Also, the UEFI code should be able to write in its own memory, which is mapped in VTL 0.) This strategy allows the Secure Kernel to avoid mapping any firmware code in VTL 1; the only part of the firmware that remains in VTL 1 is the Runtime function table itself. Keeping the table in VTL 1 allows the resume-from-hibernation code to update the UEFI runtime services' function pointer directly.

The second strategy is not optimal and is used only for allowing old systems to run with HVCI enabled. When the Secure Kernel doesn't find any MAT in the firmware, it has no choice except to map the entire UEFI runtime services code in VTL 1. Historically, multiple bugs have been discovered in the UEFI firmware code (in SMM especially). Mapping the firmware in VTL 1 could be dangerous, but it's the only solution compatible with HVCI. (New systems, as stated before, never map any UEFI firmware code in VTL 1.) At startup time, the NT Hal detects that HVCI is on and that the firmware is entirely mapped in VTL 1. So, it switches its internal EFI service table's pointer to a new table, called UEFI wrapper table. Entries of the wrapper table contain stub routines that use the *INVOKE_EFI_RUNTIME_SERVICE* secure call to enter in VTL 1. The Secure Kernel marshals the parameters, executes the firmware call, and yields the results to VTL 0. In this case, all the physical memory that describes the entire UEFI firmware is still

mapped in read-only mode in VTL 0. The goal is to allow drivers to correctly read information from the UEFI firmware memory region (like ACPI tables, for example). Old drivers that directly write into UEFI memory regions are not compatible with HVCI in this scenario.

When the Secure Kernel resumes from hibernation, it updates the in-memory UEFI service table to point to the new services' location. Furthermore, in systems that have the new UEFI firmware, the Secure Kernel reapplies the SLAT protection on each memory region mapped in VTL 0 (the Windows Loader is able to change the regions' virtual addresses if needed).

VSM startup

Although we describe the entire Windows startup and shutdown mechanism in Chapter 12, this section describes the way in which the Secure Kernel and all the VSM infrastructure is started. The Secure Kernel is dependent on the hypervisor, the Windows Loader, and the NT kernel to properly start up. We discuss the Windows Loader, the hypervisor loader, and the preliminary phases by which the Secure Kernel is initialized in VTL 0 by these two modules in Chapter 12. In this section, we focus on the VSM startup method, which is implemented in the `securekernel.exe` binary.

The first code executed by the `securekernel.exe` binary is still running in VTL 0; the hypervisor already has been started, and the page tables used for VTL 1 have been built. The Secure Kernel initializes the following components in VTL 0:

- The memory manager's initialization function stores the PFN of the VTL 0 root-level page-level structure, saves the code integrity data, and enables HVCI, MBEC (Mode-Based Execution Control), kernel CFG, and hot patching.
- Shared architecture-specific CPU components, like the GDT and IDT.
- Normal calls and secure system calls dispatch tables (initialization and compaction).
- The boot processor. The process of starting the boot processor requires the Secure Kernel to allocate its kernel and interrupt stacks; initialize the architecture-specific components, which can't be shared between different processors (like the TSS); and finally allocate the processor's SKPRCB. The latter is an important data structure, which, like the PRCB data structure in VTL 0, is used to store important information associated to each CPU.

The Secure Kernel initialization code is ready to enter VTL 1 for the first time. The hypervisor subsystem initialization function (`ShvInitSystem` routine) connects to the hypervisor (through the hypervisor CPUID classes; see the previous section for more details) and checks the supported enlightenments. Then it saves the VTL 1's page table (previously created by the Windows Loader) and the allocated hypercall pages (used for holding hypercall parameters). It finally initializes and enters VTL 1 in the following way:

1. Enables VTL 1 for the current hypervisor partition through the `HvEnablePartitionVtl` hypercall. The hypervisor copies the existing SLAT table of normal VTL to VTL 1 and enables MBEC and the new VTL 1 for the partition.
2. Enables VTL 1 for the boot processor through `HvEnableVpVtl` hypercall. The hypervisor initializes a new per-level VMCS data structure, compiles it, and sets the SLAT table.

3. Asks the hypervisor for the location of the platform-dependent *VtlCall* and *VtlReturn* hypercall code. The CPU opcodes needed for performing VSM calls are hidden from the Secure Kernel implementation. This allows most of the Secure Kernel's code to be platform-independent. Finally, the Secure Kernel executes the transition to VTL 1, through the *HvVtlCall* hypercall. The hypervisor loads the VMCS for the new VTL and switches to it (making it active). This basically renders the new VTL runnable.

The Secure Kernel starts a complex initialization procedure in VTL 1, which still depends on the Windows Loader and also on the NT kernel. It is worth noting that, at this stage, VTL 1 memory is still identity-mapped in VTL 0; the Secure Kernel and its dependent modules are still accessible to the normal world. After the switch to VTL 1, the Secure Kernel initializes the boot processor:

1. Gets the virtual address of the Synthetic Interrupt controller shared page, TSC, and VP assist page, which are provided by the hypervisor for sharing data between the hypervisor and VTL 1 code. Maps in VTL 1 the Hypercall page.
2. Blocks the possibility for other system virtual processors to be started by a lower VTL and requests the memory to be zero-filled on reboot to the hypervisor.
3. Initializes and fills the boot processor Interrupt Descriptor Table (IDT). Configures the IPI, callbacks, and secure timer interrupt handlers and sets the current secure thread as the default SKPRCB thread.
4. Starts the VTL 1 secure memory manager, which creates the boot table mapping and maps the boot loader's memory in VTL 1, creates the secure PFN database and system hyperspace, initializes the secure memory pool support, and reads the VTL 0 loader block to copy the module descriptors of the Secure Kernel's imported images (*Skci.dll*, *Cnf.sys*, and *Vmsvcext.sys*). It finally walks the NT loaded module list to establish each driver state, creating a NAR (normal address range) data structure for each one and compiling an Normal Table Entry (NTE) for every page composing the boot driver's sections. Furthermore, the secure memory manager initialization function applies the correct VTL 0 SLAT protection to each driver's sections.
5. Initializes the HAL, the secure threads pool, the process subsystem, the synthetic APIC, Secure PNP, and Secure PCI.
6. Applies a read-only VTL 0 SLAT protection for the Secure Kernel pages, configures MBEC, and enables the VINA virtual interrupt on the boot processor.

When this part of the initialization ends, the Secure Kernel unmaps the boot-loaded memory. The secure memory manager, as we discuss in the next section, depends on the VTL 0 memory manager for being able to allocate and free VTL 1 memory. VTL 1 does not own any physical memory; at this stage, it relies on some previously allocated (by the Windows Loader) physical pages for being able to satisfy memory allocation requests. When the NT kernel later starts, the Secure Kernel performs normal calls for requesting memory services to the VTL 0 memory manager. As a result, some parts of the Secure Kernel initialization must be deferred after the NT kernel is started. Execution flow returns to the Windows Loader in VTL 0. The latter loads and starts the NT kernel. The last part of the Secure Kernel initialization happens in phase 0 and phase 1 of the NT kernel initialization (see Chapter 12 for further details).

Phase 0 of the NT kernel initialization still has no memory services available, but this is the last moment in which the Secure Kernel fully trusts the normal world. Boot-loaded drivers still have not been initialized and the initial boot process should have been already protected by Secure Boot. The `PHASE3_INIT` secure call handler modifies the SLAT protections of all the physical pages belonging to Secure Kernel and to its depended modules, rendering them inaccessible to VTL 0. Furthermore, it applies a read-only protection to the kernel CFG bitmaps. At this stage, the Secure Kernel enables the support for pagefile integrity, creates the initial system process and its address space, and saves all the “trusted” values of the shared CPU registers (like IDT, GDT, Syscall MSR, and so on). The data structures that the shared registers point to are verified (thanks to the NTE database). Finally, the secure thread pool is started and the object manager, the secure code integrity module (`Skci.dll`), and HyperGuard are initialized (more details on HyperGuard are available in Chapter 7 of Part 1).

When the execution flow is returned to VTL 0, the NT kernel can then start all the other application processors (APs). When the Secure Kernel is enabled, the AP’s initialization happens in a slightly different way (we discuss AP initialization in the next section).

As part of the phase 1 of the NT kernel initialization, the system starts the I/O manager. The I/O manager, as discussed in Part 1, Chapter 6, “I/O system,” is the core of the I/O system and defines the model within which I/O requests are delivered to device drivers. One of the duties of the I/O manager is to initialize and start the boot-loaded and ELAM drivers. Before creating the special sections for mapping the user mode system DLLs, the I/O manager initialization function emits a `PHASE4_INIT` secure call to start the last initialization phase of the Secure Kernel. At this stage, the Secure Kernel does not trust the VTL 0 anymore, but it can use the services provided by the NT memory manager. The Secure Kernel initializes the content of the Secure User Shared data page (which is mapped both in VTL 1 user mode and kernel mode) and finalizes the executive subsystem initialization. It reclaims any resources that were reserved during the boot process, calls each of its own dependent module entry points (in particular, `cng.sys` and `vmsvcext.sys`, which start before any normal boot drivers). It allocates the necessary resources for the encryption of the hibernation, crash-dump, paging files, and memory-page integrity. It finally reads and maps the API set schema file in VTL 1 memory. At this stage, VSM is completely initialized.

Application processors (APs) startup

One of the security features provided by the Secure Kernel is the startup of the application processors (APs), which are the ones not used to boot up the system. When the system starts, the Intel and AMD specifications of the x86 and AMD64 architectures define a precise algorithm that chooses the boot strap processor (BSP) in multiprocessor systems. The boot processor always starts in 16-bit real mode (where it’s able to access only 1 MB of physical memory) and usually executes the machine’s firmware code (UEFI in most cases), which needs to be located at a specific physical memory location (the location is called reset vector). The boot processor executes almost all of the initialization of the OS, hypervisor, and Secure Kernel. For starting other non-boot processors, the system needs to send a special IPI (inter-processor interrupt) to the local APICs belonging to each processor. The startup IPI (SIPI) vector contains the physical memory address of the processor start block, a block of code that includes the instructions for performing the following basic operations:

1. Load a GDT and switch from 16-bit real-mode to 32-bit protected mode (with no paging enabled).

2. Set a basic page table, enable paging, and enter 64-bit long mode.
3. Load the 64-bit IDT and GDT, set the proper processor registers, and jump to the OS startup function (*KiSystemStartup*).

This process is vulnerable to malicious attacks. The processor startup code could be modified by external entities while it is executing on the AP processor (the NT kernel has no control at this point). In this case, all the security promises brought by VSM could be easily fooled. When the hypervisor and the Secure Kernel are enabled, the application processors are still started by the NT kernel but using the hypervisor.

KeStartAllProcessors, which is the function called by phase 1 of the NT kernel initialization (see Chapter 12 for more details), with the goal of starting all the APs, builds a shared IDT and enumerates all the available processors by consulting the Multiple APIC Description Table (MADT) ACPI table. For each discovered processor, it allocates memory for the PRCB and all the private CPU data structures for the kernel and DPC stack. If the VSM is enabled, it then starts the AP by sending a *START_PROCESSOR* secure call to the Secure Kernel. The latter validates that all the data structures allocated and filled for the new processor are valid, including the initial values of the processor registers and the startup routine (*KiSystemStartup*) and ensures that the APs startups happen sequentially and only once per processor. It then initializes the VTL 1 data structures needed for the new application processor (the SKPRCB in particular). The PRCB thread, which is used for dispatching the Secure Calls in the context of the new processor, is started, and the VTL 0 CPU data structures are protected by using the SLAT. The Secure Kernel finally enables VTL 1 for the new application processor and starts it by using the *HvStartVirtualProcessor* hypercall. The hypervisor starts the AP in a similar way described in the beginning of this section (by sending the startup IPI). In this case, however, the AP starts its execution in the hypervisor context, switches to 64-bit long mode execution, and returns to VTL 1.

The first function executed by the application processor resides in VTL 1. The Secure Kernel's CPU initialization routine maps the per-processor VP assist page and SynIC control page, configures MBEC, and enables the VINA. It then returns to VTL 0 through the *HvVtlReturn* hypercall. The first routine executed in VTL 0 is *KiSystemStartup*, which initializes the data structures needed by the NT kernel to manage the AP, initializes the HAL, and jumps to the idle loop (read more details in Chapter 12). The Secure Call dispatch loop is initialized later by the normal NT kernel when the first secure call is executed.

An attacker in this case can't modify the processor startup block or any initial value of the CPU's registers and data structures. With the described secure AP start-up, any modification would have been detected by the Secure Kernel and the system bug checked to defeat any attack effort.

The Secure Kernel memory manager

The Secure Kernel memory manager heavily depends on the NT memory manager (and on the Windows Loader memory manager for its startup code). Entirely describing the Secure Kernel memory manager is outside the scope of this book. Here we discuss only the most important concepts and data structures used by the Secure Kernel.

As mentioned in the previous section, the Secure Kernel memory manager initialization is divided into three phases. In phase 1, the most important, the memory manager performs the following:

1. Maps the boot loader firmware memory descriptor list in VTL 1, scans the list, and determines the first physical page that it can use for allocating the memory needed for its initial startup (this memory type is called SLAB). Maps the VTL 0's page tables in a virtual address that is located exactly 512 GB before the VTL 1's page table. This allows the Secure Kernel to perform a fast conversion between an NT virtual address and one from the Secure Kernel.
2. Initializes the PTE range data structures. A PTE range contains a bitmap that describes each chunk of allocated virtual address range and helps the Secure Kernel to allocate PTEs for its own address space.
3. Creates the Secure PFN database and initializes the Memory pool.
4. Initializes the sparse NT address table. For each boot-loaded driver, it creates and fills a NAR, verifies the integrity of the binary, fills the hot patch information, and, if HVCI is on, protects each executable section of driver using the SLAT. It then cycles between each PTE of the memory image and writes an NT Address Table Entry (NTE) in the NT address table.
5. Initializes the page bundles.

The Secure Kernel keeps track of the memory that the normal NT kernel uses. The Secure Kernel memory manager uses the *NAR* data structure for describing a kernel virtual address range that contains executable code. The NAR contains some information of the range (such as its base address and size) and a pointer to a *SECURE_IMAGE* data structure, which is used for describing runtime drivers (in general, images verified using Secure HVCI, including user mode images used for trustlets) loaded in VTL 0. Boot-loaded drivers do not use the *SECURE_IMAGE* data structure because they are treated by the NT memory manager as private pages that contain executable code. The latter data structure contains information regarding a loaded image in the NT kernel (which is verified by SKCI), like the address of its entry point, a copy of its relocation tables (used also for dealing with Retpoline and Import Optimization), the pointer to its shared prototype PTEs, hot-patch information, and a data structure that specifies the authorized use of its memory pages. The *SECURE_IMAGE* data structure is very important because it's used by the Secure Kernel to track and verify the shared memory pages that are used by runtime drivers.

For tracking VTL 0 kernel private pages, the Secure Kernel uses the NTE data structure. An NTE exists for every virtual page in the VTL 0 address space that requires supervision from the Secure Kernel; it's often used for private pages. An NTE tracks a VTL 0 virtual page's PTE and stores the page state and protection. When HVCI is enabled, the NTE table divides all the virtual pages between privileged and non-privileged. A privileged page represents a memory page that the NT kernel is not able to touch on its own because it's protected through SLAT and usually corresponds to an executable page or to a kernel CFG read-only page. A nonprivileged page represents all the other types of memory pages that the NT kernel has full control over. The Secure Kernel uses invalid NTEs to represent nonprivileged pages. When HVCI is off, all the private pages are nonprivileged (the NT kernel has full control of all its pages indeed).

In HVCI-enabled systems, the NT memory manager can't modify any protected pages. Otherwise, an EPT violation exception will raise in the hypervisor, resulting in a system crash. After those systems

complete their boot phase, the Secure Kernel has already processed all the nonexecutable physical pages by SLAT-protecting them only for read and write access. In this scenario, new executable pages can be allocated only if the target code has been verified by Secure HVCI.

When the system, an application, or the Plug and Play manager require the loading of a new runtime driver, a complex procedure starts that involves the NT and the Secure Kernel memory manager, summarized here:

1. The NT memory manager creates a section object, allocates and fills a new Control area (more details about the NT memory manager are available in Chapter 5 of Part 1), reads the first page of the binary, and calls the Secure Kernel with the goal to create the relative secure image, which describe the new loaded module.
2. The Secure Kernel creates the *SECURE_IMAGE* data structure, parses all the sections of the binary file, and fills the secure prototype PTEs array.
3. The NT kernel reads the entire binary in nonexecutable shared memory (pointed by the prototype PTEs of the control area). Calls the Secure Kernel, which, using Secure HVCI, cycles between each section of the binary image and calculates the final image hash.
4. If the calculated file hash matches the one stored in the digital signature, the NT memory walks the entire image and for each page calls the Secure Kernel, which validates the page (each page hash has been already calculated in the previous phase), applies the needed relocations (ASLR, Retpoline, and Import Optimization), and applies the new SLAT protection, allowing the page to be executable but not writable anymore.
5. The Section object has been created. The NT memory manager needs to map the driver in its address space. It calls the Secure Kernel for allocating the needed privileged PTEs for describing the driver's virtual address range. The Secure Kernel creates the *NAR* data structure. It then maps the physical pages of the driver, which have been previously verified, using the *MiMapSystemImage* routine.



Note When a NARs is initialized for a runtime driver, part of the NTE table is filled for describing the new driver address space. The NTEs are not used for keeping track of a runtime driver's virtual address range (its virtual pages are shared and not private), so the relative part of the NT address table is filled with invalid "reserved" NTEs.

While VTL 0 kernel virtual address ranges are represented using the NAR data structure, the Secure Kernel uses secure VADs (virtual address descriptors) to track user-mode virtual addresses in VTL 1. Secure VADs are created every time a new private virtual allocation is made, a binary image is mapped in the address space of a trustlet (secure process), and when a VBS-enclave is created or a module is mapped into its address space. A secure VAD is similar to the NT kernel VAD and contains a descriptor of the VA range, a reference counter, some flags, and a pointer to the Secure section, which has been created by SKCI. (The secure section pointer is set to 0 in case of secure VADs describing private virtual allocations.) More details about Trustlets and VBS-based enclaves will be discussed later in this chapter.

Page identity and the secure PFN database

After a driver is loaded and mapped correctly into VTL 0 memory, the NT memory manager needs to be able to manage its memory pages (for various reasons, like the paging out of a pageable driver's section, the creation of private pages, the application of private fixups, and so on; see Chapter 5 in Part 1 for more details). Every time the NT memory manager operates on protected memory, it needs the cooperation of the Secure Kernel. Two main kinds of secure services are offered to the NT memory manager for operating with privileged memory: protected pages copy and protected pages removal.

A *PAGE_IDENTITY* data structure is the glue that allows the Secure Kernel to keep track of all the different kinds of pages. The data structure is composed of two fields: an Address Context and a Virtual Address. Every time the NT kernel calls the Secure Kernel for operating on privileged pages, it needs to specify the physical page number along with a valid *PAGE_IDENTITY* data structure describing what the physical page is used for. Through this data structure, the Secure Kernel can verify the requested page usage and decide whether to allow the request.

Table 9-4 shows the *PAGE_IDENTITY* data structure (second and third columns), and all the types of verification performed by the Secure Kernel on different memory pages:

- If the Secure Kernel receives a request to copy or to release a shared executable page of a runtime driver, it validates the secure image handle (specified by the caller) and gets its relative data structure (*SECURE_IMAGE*). It then uses the relative virtual address (RVA) as an index into the secure prototype array to obtain the physical page frame (PFN) of the driver's shared page. If the found PFN is equal to the caller's specified one, the Secure Kernel allows the request; otherwise it blocks it.
- In a similar way, if the NT kernel requests to operate on a trustlet or an enclave page (more details about trustlets and secure enclaves are provided later in this chapter), the Secure Kernel uses the caller's specified virtual address to verify that the secure PTE in the secure process page table contains the correct PFN.
- As introduced earlier in the section "The Secure Kernel memory manager", for private kernel pages, the Secure Kernel locates the NTE starting from the caller's specified virtual address and verifies that it contains a valid PFN, which must be the same as the caller's specified one.
- Placeholder pages are free pages that are SLAT protected. The Secure Kernel verifies the state of a placeholder page by using the PFN database.

TABLE 9-4 Different page identities managed by the Secure Kernel

Page Type	Address Context	Virtual Address	Verification Structure
Kernel Shared	Secure Image Handle	RVA of the page	Secure Prototype PTE
Trustlet/Enclave	Secure Process Handle	Virtual Address of the Secure Process	Secure PTE
Kernel Private	0	Kernel Virtual Address of the page	NT address table entry (NTE)
Placeholder	0	0	PFN entry

The Secure Kernel memory manager maintains a PFN database to represent the state of each physical page. A PFN entry in the Secure Kernel is much smaller compared to its NT equivalent; it basically contains the page state and the share counter. A physical page, from the Secure Kernel perspective, can be in one of the following states: invalid, free, shared, I/O, secured, or image (secured NT private).

The secured state is used for physical pages that are private to the Secure Kernel (the NT kernel can never claim them) or for physical pages that have been allocated by the NT kernel and later SLAT-protected by the Secure Kernel for storing executable code verified by Secure HVCI. Only secured nonprivate physical pages have a page identity.

When the NT kernel is going to page out a protected page, it asks the Secure Kernel for a page removal operation. The Secure Kernel analyzes the specified page identity and does its verification (as explained earlier). In case the page identity refers to an enclave or a trustlet page, the Secure Kernel encrypts the page's content before releasing it to the NT kernel, which will then store the page in the paging file. In this way, the NT kernel still has no chance to intercept the real content of the private memory.

Secure memory allocation

As discussed in previous sections, when the Secure Kernel initially starts, it parses the firmware's memory descriptor lists, with the goal of being able to allocate physical memory for its own use. In phase 1 of its initialization, the Secure Kernel can't use the memory services provided by the NT kernel (the NT kernel indeed is still not initialized), so it uses free entries of the firmware's memory descriptor lists for reserving 2-MB SLABs. A SLAB is a 2-MB contiguous physical memory, which is mapped by a single nested page table directory entry in the hypervisor. All the SLAB pages have the same SLAT protection. SLABs have been designed for performance considerations. By mapping a 2-MB chunk of physical memory using a single nested page entry in the hypervisor, the additional hardware memory address translation is faster and results in less cache misses on the SLAT table.

The first Secure Kernel *page bundle* is filled with 1 MB of the allocated SLAB memory. A page bundle is the data structure shown in Figure 9-37, which contains a list of contiguous free physical page frame numbers (PFNs). When the Secure Kernel needs memory for its own purposes, it allocates physical pages from a page bundle by removing one or more free page frames from the tail of the bundle's PFNs array. In this case, the Secure Kernel doesn't need to check the firmware memory descriptors list until the bundle has been entirely consumed. When the phase 3 of the Secure Kernel initialization is done, memory services of the NT kernel become available, and so the Secure Kernel frees any boot memory descriptor lists, retaining physical memory pages previously located in bundles.

Future secure memory allocations use normal calls provided by the NT kernel. Page bundles have been designed to minimize the number of normal calls needed for memory allocation. When a bundle gets fully allocated, it contains no pages (all its pages are currently assigned), and a new one will be generated by asking the NT kernel for 1 MB of contiguous physical pages (through the `ALLOC_PHYSICAL_PAGES` normal call). The physical memory will be allocated by the NT kernel from the proper SLAB.

In the same way, every time the Secure Kernel frees some of its private memory, it stores the corresponding physical pages in the correct bundle by growing its PFN array until the limit of 256 free pages. When the array is entirely filled, and the bundle becomes free, a new work item is queued. The work item will zero-out all the pages and will emit a *FREE_PHYSICAL_PAGES* normal call, which ends up in executing the *MmFreePagesFromMdl* function of the NT memory manager.

Every time enough pages are moved into and out of a bundle, they are fully protected in VTL 0 by using the SLAT (this procedure is called “securing the bundle”). The Secure Kernel supports three kinds of bundles, which all allocate memory from different SLABs: No access, Read-only, and Read-Execute.

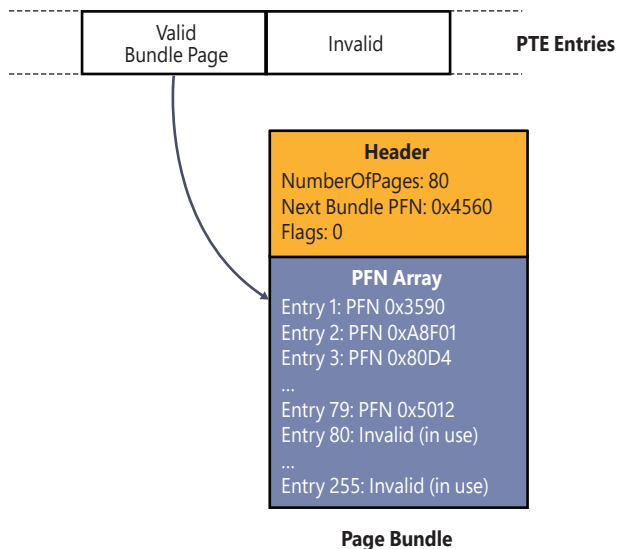

FIGURE 9-37 A secure page bundle with 80 available pages. A bundle is composed of a header and a free PFNs array.

Hot patching

Several years ago, the 32-bit versions of Windows were supporting the hot patch of the operating-system’s components. Patchable functions contained a redundant 2-byte opcode in their prolog and some padding bytes located before the function itself. This allowed the NT kernel to dynamically replace the initial opcode with an indirect jump, which uses the free space provided by the padding, to divert the code to a patched function residing in a different module. The feature was heavily used by Windows Update, which allowed the system to be updated without the need for an immediate reboot of the machine. When moving to 64-bit architectures, this was no longer possible due to various problems. Kernel patch protection was a good example; there was no longer a reliable way to modify a protected kernel mode binary and to allow PatchGuard to be updated without exposing some of its private interfaces, and exposed PatchGuard interfaces could have been easily exploited by an attacker with the goal to defeat the protection.

The Secure Kernel has solved all the problems related to 64-bit architectures and has reintroduced to the OS the ability of hot patching kernel binaries. While the Secure Kernel is enabled, the following types of executable images can be hot patched:

- VTL 0 user-mode modules (both executables and libraries)
- Kernel mode drivers, HAL, and the NT kernel binary, protected or not by PatchGuard
- The Secure Kernel binary and its dependent modules, which run in VTL 1 Kernel mode
- The hypervisor (Intel, AMD, and the ARM version).

Patch binaries created for targeting software running in VTL 0 are called normal patches, whereas the others are called secure patches. If the Secure Kernel is not enabled, only user mode applications can be patched.

A hot patch image is a standard Portable Executable (PE) binary that includes the hot patch table, the data structure used for tracking the patch functions. The hot patch table is linked in the binary through the image load configuration data directory. It contains one or more descriptors that describe each patchable base image, which is identified by its checksum and time date stamp. (In this way, a hot patch is compatible only with the correct base images. The system can't apply a patch to the wrong image.) The hot patch table also includes a list of functions or global data chunks that needs to be updated in the base or in the patch image; we describe the patch engine shortly. Every entry in this list contains the functions' offsets in the base and patch images and the original bytes of the base function that will be replaced.

Multiple patches can be applied to a base image, but the patch application is idempotent. The same patch may be applied multiple times, or different patches may be applied in sequence. Regardless, the last applied patch will be the active patch for the base image. When the system needs to apply a hot patch, it uses the *NtManageHotPatch* system call, which is employed to install, remove, or manage hot patches. (The system call supports different "patch information" classes for describing all the possible operations.) A hot patch can be installed globally for the entire system, or, if a patch is for user mode code (VTL 0), for all the processes that belong to a specific user session.

When the system requests the application of a patch, the NT kernel locates the hot patch table in the patch binary and validates it. It then uses the *DETERMINE_HOT_PATCH_TYPE* secure call to securely determine the type of patch. In the case of a secure patch, only the Secure Kernel can apply it, so the *APPLY_HOT_PATCH* secure call is used; no other processing by the NT kernel is needed. In all the other cases, the NT kernel first tries to apply the patch to a kernel driver. It cycles between each loaded kernel module, searching for a base image that has the same checksum described by one of the patch image's hot patch descriptors.

Hot patching is enabled only if the `HKEY_LOCAL_MACHINE\SYSTEM\CurrentControlSet\Control\Session Manager\Memory Management\HotPatchTableSize` registry value is a multiple of a standard memory page size (4,096). Indeed, when hot patching is enabled, every image that is mapped in the virtual address space needs to have a certain amount of virtual address space reserved immediately after the image itself. This reserved space is used for the image's hot patch address table (HPAT, not to be confused with the hot patch table). The HPAT is used to minimize the amount of padding necessary for each function to be patched by storing the address of the new function in the patched image.

When patching a function, the HPAT location will be used to perform an indirect jump from the original function in the base image to the patched function in the patch image (note that for Retpoline compatibility, another kind of Retpoline routine is used instead of an indirect jump).

When the NT kernel finds a kernel mode driver suitable for the patch, it loads and maps the patch binary in the kernel address space and creates the related loader data table entry (for more details, see Chapter 12). It then scans each memory page of both the base and the patch images and locks in memory the ones involved in the hot patch (this is important; in this way, the pages can't be paged out to disk while the patch application is in progress). It finally emits the *APPLY_HOT_PATCH* secure call.

The real patch application process starts in the Secure Kernel. The latter captures and verifies the hot patch table of the patch image (by remapping the patch image also in VTL 1) and locates the base image's NAR (see the previous section, "The Secure Kernel memory manager" for more details about the NARs), which also tells the Secure Kernel whether the image is protected by PatchGuard. The Secure Kernel then verifies whether enough reserved space is available in the image HPAT. If so, it allocates one or more free physical pages (getting them from the secure bundle or using the *ALLOC_PHYSICAL_PAGES* normal call) that will be mapped in the reserved space. At this point, if the base image is protected, the Secure Kernel starts a complex process that updates the PatchGuard's internal state for the new patched image and finally calls the patch engine.

The kernel's patch engine performs the following high-level operations, which are all described by a different entry type in the hot patch table:

1. Patches all calls from patched functions in the patch image with the goal to jump to the corresponding functions in the base image. This ensures that all unpatched code always executes in the original base image. For example, if function A calls B in the base image and the patch changes function A but not function B, then the patch engine will update function B in the patch to jump to function B in the base image.
2. Patches the necessary references to global variables in patched functions to point to the corresponding global variables in the base image.
3. Patches the necessary import address table (IAT) references in the patch image by copying the corresponding IAT entries from the base image.
4. Atomically patches the necessary functions in the base image to jump to the corresponding function in the patch image. As soon as this is done for a given function in the base image, all new invocations of that function will execute the new patched function code in the patch image. When the patched function returns, it will return to the caller of the original function in the base image.

Since the pointers of the new functions are 64 bits (8 bytes) wide, the patch engine inserts each pointer in the HPAT, which is located at the end of the binary. In this way, it needs only 5 bytes for placing the indirect jump in the padding space located in the beginning of each function (the process has been simplified. Retpoline compatible hot-patches requires a compatible Retpoline. Furthermore, the HPAT is split in code and data page).

As shown in Figure 9-38, the patch engine is compatible with different kinds of binaries. If the NT kernel has not found any patchable kernel mode module, it restarts the search through all the user

mode processes and applies a procedure similar to properly hot patching a compatible user mode executable or library.

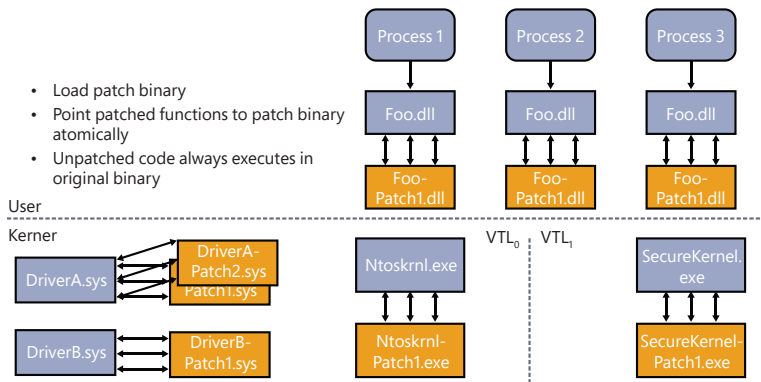

FIGURE 9-38 A schema of the hot patch engine executing on different types of binaries.

Isolated User Mode

Isolated User Mode (IUM), the services provided by the Secure Kernel to its secure processes (trustlets), and the trustlets general architecture are covered in Chapter 3 of Part 1. In this section, we continue the discussion starting from there, and we move on to describe some services provided by the Isolated User Mode, like the secure devices and the VBS enclaves.

As introduced in Chapter 3 of Part 1, when a trustlet is created in VTL 1, it usually maps in its address space the following libraries:

- **lumdll.dll** The IUM Native Layer DLL implements the secure system call stub. It's the equivalent of Ntdll.dll of VTL 0.
- **lumbase.dll** The IUM Base Layer DLL is the library that implements most of the secure APIs that can be consumed exclusively by VTL 1 software. It provides various services to each secure process, like secure identification, communication, cryptography, and secure memory management. Trustlets do not usually call secure system calls directly, but they pass through lumbase.dll, which is the equivalent of kernelbase.dll in VTL 0.
- **lumCrypt.dll** Exposes public/private key encryption functions used for signing and integrity verification. Most of the crypto functions exposed to VTL 1 are implemented in lumbase.dll; only a small number of specialized encryption routines are implemented in lumCrypt. Lsalso is the main consumer of the services exposed by lumCrypt, which is not loaded in many other trustlets.
- **Ntdll.dll, Kernelbase.dll, and Kernel32.dll** A trustlet can be designed to run both in VTL 1 and VTL 0. In that case, it should only use routines implemented in the standard VTL 0 API surface. Not all the services available to VTL 0 are also implemented in VTL 1. For example, a trustlet can never do any registry I/O and any file I/O, but it can use synchronization routines, ALPC, thread APIs, and structured exception handling, and it can manage virtual memory and

section objects. Almost all the services offered by the kernelbase and kernel32 libraries perform system calls through Ntdll.dll. In VTL 1, these kinds of system calls are “translated” in normal calls and redirected to the VTL 0 kernel. (We discussed normal calls in detail earlier in this chapter.) Normal calls are often used by IUM functions and by the Secure Kernel itself. This explains why ntdll.dll is always mapped in every trustlet.

- **Vertdll.dll** The VSM enclave runtime DLL is the DLL that manages the lifetime of a VBS enclave. Only limited services are provided by software executing in a secure enclave. This library implements all the enclave services exposed to the software enclave and is normally not loaded for standard VTL 1 processes.

With this knowledge in mind, let’s look at what is involved in the trustlet creation process, starting from the *CreateProcess* API in VTL 0, for which its execution flow has already been described in detail in Chapter 3.

Trustlets creation

As discussed multiple times in the previous sections, the Secure Kernel depends on the NT kernel for performing various operations. Creating a trustlet follows the same rule: It is an operation that is managed by both the Secure Kernel and NT kernel. In Chapter 3 of Part 1, we presented the trustlet structure and its signing requirement, and we described its important policy metadata. Furthermore, we described the detailed flow of the *CreateProcess* API, which is still the starting point for the trustlet creation.

To properly create a trustlet, an application should specify the *CREATE_SECURE_PROCESS* creation flag when calling the *CreateProcess* API. Internally, the flag is converted to the *PS_CP_SECURE_PROCESS* NT attribute and passed to the *NtCreateUserProcess* native API. After the *NtCreateUserProcess* has successfully opened the image to be executed, it creates the section object of the image by specifying a special flag, which instructs the memory manager to use the Secure HVCI to validate its content. This allows the Secure Kernel to create the *SECURE_IMAGE* data structure used to describe the PE image verified through Secure HVCI.

The NT kernel creates the required process’s data structures and initial VTL 0 address space (page directories, hyperspace, and working set) as for normal processes, and if the new process is a trustlet, it emits a *CREATE_PROCESS* secure call. The Secure Kernel manages the latter by creating the secure process object and relative data structure (named *SEPROCESS*). The Secure Kernel links the normal process object (EPROCESS) with the new secure one and creates the initial secure address space by allocating the secure page table and duplicating the root entries that describe the kernel portion of the secure address space in the upper half of it.

The NT kernel concludes the setup of the empty process address space and maps the Ntdll library into it (see Stage 3D of Chapter 3 of Part 1 for more details). When doing so for secure processes, the NT kernel invokes the *INITIALIZE_PROCESS* secure call to finish the setup in VTL 1. The Secure Kernel copies the trustlet identity and trustlet attributes specified at process creation time into the new secure process, creates the secure handle table, and maps the secure shared page into the address space.

The last step needed for the secure process is the creation of the secure thread. The initial thread object is created as for normal processes in the NT kernel: When the *NtCreateUserProcess* calls

PspInsertThread, it has already allocated the thread kernel stack and inserted the necessary data to start from the *KiStartUserThread* kernel function (see Stage 4 in Chapter 3 of Part 1 for further details). If the process is a trustlet, the NT kernel emits a *CREATE_THREAD* secure call for performing the final secure thread creation. The Secure Kernel attaches to the new secure process's address space and allocates and initializes a secure thread data structure, a thread's secure TEB, and kernel stack. The Secure Kernel fills the thread's kernel stack by inserting the thread-first initial kernel routine: *SkpUserThreadStart*. It then initializes the machine-dependent hardware context for the secure thread, which specifies the actual image start address and the address of the first user mode routine. Finally, it associates the normal thread object with the new created secure one, inserts the thread into the secure threads list, and marks the thread as runnable.

When the normal thread object is selected to run by the NT kernel scheduler, the execution still starts in the *KiStartUserThread* function in VTL 0. The latter lowers the thread's IRQL and calls the system initial thread routine (*PspUserThreadStartup*). The execution proceeds as for normal threads, until the NT kernel sets up the initial thunk context. Instead of doing that, it starts the Secure Kernel dispatch loop by calling the *VslpEnterLumSecureMode* routine and specifying the *RESUMETHREAD* secure call. The loop will exit only when the thread is terminated. The initial secure call is processed by the normal call dispatcher loop in VTL 1, which identifies the "resume thread" entry reason to VTL 1, attaches to the new process's address space, and switches to the new secure thread stack. The Secure Kernel in this case does not call the *lumInvokeSecureService* dispatcher function because it knows that the initial thread function is on the stack, so it simply returns to the address located in the stack, which points to the VTL 1 secure initial routine, *SkpUserThreadStart*.

SkpUserThreadStart, similarly to standard VTL 0 threads, sets up the initial thunk context to run the image loader initialization routine (*LdrInitializeThunk* in *Ntdll.dll*), as well as the system-wide thread startup stub (*RtlUserThreadStart* in *Ntdll.dll*). These steps are done by editing the context of the thread in place and then issuing an exit from system service operation, which loads the specially crafted user context and returns to user mode. The newborn secure thread initialization proceeds as for normal VTL 0 threads; the *LdrInitializeThunk* routine initializes the loader and its needed data structures. Once the function returns, *NtContinue* restores the new user context. Thread execution now truly starts: *RtlUserThreadStart* uses the address of the actual image entry point and the start parameter and calls the application's entry point.



Note A careful reader may have noticed that the Secure Kernel doesn't do anything to protect the new trustlet's binary image. This is because the shared memory that describes the trustlet's base binary image is still accessible to VTL 0 by design.

Let's assume that a trustlet wants to write private data located in the image's global data. The PTEs that map the writable data section of the image global data are marked as copy-on-write. So, an access fault will be generated by the processor. The fault belongs to a user mode address range (remember that no NAR are used to track shared pages). The Secure Kernel page fault handler transfers the execution to the NT kernel (through a normal call), which will allocate a new page, copy the content of the old one in it, and protect it through the SLAT (using a protected copy operation; see the section "The Secure Kernel memory manager" earlier in this chapter for further details).

EXPERIMENT: Debugging a trustlet

Debugging a trustlet with a user mode debugger is possible only if the trustlet explicitly allows it through its policy metadata (stored in the .tPolicy section). In this experiment, we try to debug a trustlet through the kernel debugger. You need a kernel debugger attached to a test system (a local kernel debugger works, too), which must have VBS enabled. HVCI is not strictly needed, though.

First, find the Lsalso.exe trustlet:

```
1kd> !process 0 0 lsaiso.exe
PROCESS ffff8904dfdaa080
  SessionId: 0 Cid: 02e8 Peb: 8074164000 ParentCid: 0250
  DirBase: 3e590002 ObjectTable: fffffb00d0f4dab00 HandleCount: 42.
  Image: LsaIso.exe
```

Analyzing the process's PEB reveals that some information is set to 0 or nonreadable:

```
1kd> .process /P ffff8904dfdaa080
1kd> !peb 8074164000
PEB at 0000008074164000
  InheritedAddressSpace: No
  ReadImageFileExecOptions: No
  BeingDebugged: No
  ImageBaseAddress: 00007ff708750000
  NtGlobalFlag: 0
  NtGlobalFlag2: 0
  Ldr 0000000000000000
  *** unable to read Ldr table at 0000000000000000
  SubSystemData: 0000000000000000
  ProcessHeap: 0000000000000000
  ProcessParameters: 0000026b55a10000
  CurrentDirectory: 'C:\Windows\system32\'
  WindowTitle: '< Name not readable >'
  ImageFile: '\??\C:\Windows\system32\lsaiso.exe'
  CommandLine: '\??\C:\Windows\system32\lsaiso.exe'
  DllPath: '< Name not readable >'1kd
```

Reading from the process image base address may succeed, but it depends on whether the Lsalso image mapped in the VTL 0 address space has been already accessed. This is usually the case just for the first page (remember that the shared memory of the main image is accessible in VTL 0). In our system, the first page is mapped and valid, whereas the third one is invalid:

```
1kd> db 0x7ff708750000 120
00007ff7`08750000 4d 5a 90 00 03 00 00 00-04 00 00 00 ff 00 00 MZ.....
00007ff7`08750010 b8 00 00 00 00 00 00 00-40 00 00 00 00 00 00 .....@.....
1kd> db (0x7ff708750000 + 2000) 120
00007ff7`08752000 ?? ?? ?? ?? ?? ?? ?? ??-?? ?? ?? ?? ?? ?? ?? ????
00007ff7`08752010 ?? ?? ?? ?? ?? ?? ?? ??-?? ?? ?? ?? ?? ?? ?? ????
1kd> !pte (0x7ff708750000 + 2000)
1: kd> !pte (0x7ff708750000 + 2000)
```

```

                                VA 00007ff708752000
PXE at FFFFD5EAF57AB7F8   PPE at FFFFD5EAF56FFEE0   PDE at FFFFD5EADFFDC218
contains 0A0000003E58D867   contains 0A0000003E58E867   contains 0A0000003E58F867
pfn 3e58d   ---DA--UWEV   pfn 3e58e   ---DA--UWEV   pfn 3e58f   ---DA--UWEV

```

```

PTE at FFFFD5BFFB843A90
contains 0000000000000000
not valid

```

Dumping the process's threads reveals important information that confirms what we have discussed in the previous sections:

```

!process ffff8904dfdaa080 2
PROCESS ffff8904dfdaa080
  SessionId: 0 Cid: 02e8   Peb: 8074164000 ParentCid: 0250
  DirBase: 3e590002 ObjectTable: fffffb00d0f4dab00 HandleCount: 42.
  Image: LsaIso.exe

  THREAD ffff8904dfdd9080 Cid 02e8.02f8 Teb: 0000008074165000
  Win32Thread: 0000000000000000 WAIT: (UserRequest) UserMode Non-Alertable
  ffff8904dfdc5ca0 NotificationEvent

  THREAD ffff8904e12ac040 Cid 02e8.0b84 Teb: 0000008074167000
  Win32Thread: 0000000000000000 WAIT: (WrQueue) UserMode Alertable
  ffff8904dfdd7440 QueueObject

```

```

!kd> .thread /p ffff8904e12ac040
Implicit thread is now ffff8904`e12ac040
Implicit process is now ffff8904`dfdaa080
.cache forcedecodeuser done
!kd> k
*** Stack trace for last set context - .thread/.cxr resets it
# Child-SP          RetAddr           Call Site
00 fffffe009`1216c140 ffffff801`27564e17 nt!KiSwapContext+0x76
01 fffffe009`1216c280 ffffff801`27564989 nt!KiSwapThread+0x297
02 fffffe009`1216c340 ffffff801`275681f9 nt!KiCommitThreadWait+0x549
03 fffffe009`1216c3e0 ffffff801`27567369 nt!KeRemoveQueueEx+0xb59
04 fffffe009`1216c480 ffffff801`27568e2a nt!IoRemoveIoCompletion+0x99
05 fffffe009`1216c5b0 ffffff801`2764d504 nt!NtWaitForWorkViaWorkerFactory+0x99a
06 fffffe009`1216c7e0 ffffff801`276db75f nt!Vs!pDispatchIumSyscall+0x34
07 fffffe009`1216c860 ffffff801`27bab7e4 nt!Vs!pEnterIumSecureMode+0x12098b
08 fffffe009`1216c8d0 ffffff801`276586cc nt!PspUserThreadStartup+0x178704
09 fffffe009`1216c9c0 ffffff801`27658640 nt!KiStartUserThread+0x1c
0a fffffe009`1216cb00 00007fff`d06f7ab0 nt!KiStartUserThreadReturn
0b 00000080`7427fe18 00000000`00000000 ntdll!RtlUserThreadStart

```

The stack clearly shows that the execution begins in VTL 0 at the *KiStartUserThread* routine. *PspUserThreadStartup* has invoked the secure call dispatch loop, which never ended and has been interrupted by a wait operation. There is no way for the kernel debugger to show any Secure Kernel's data structures or trustlet's private data.

Secure devices

VBS provides the ability for drivers to run part of their code in the secure environment. The Secure Kernel itself can't be extended to support kernel drivers; its attack surface would become too large. Furthermore, Microsoft wouldn't allow external companies to introduce possible bugs in a component used primarily for security purposes.

The User-Mode Driver Framework (UMDF) solves the problem by introducing the concept of driver companions, which can run both in user mode VTL 0 or VTL 1. In this case, they take the name of *secure companions*. A secure companion takes the subset of the driver's code that needs to run in a different mode (in this case IUM) and loads it as an extension, or companion, of the main KMDF driver. Standard WDM drivers are also supported, though. The main driver, which still runs in VTL 0 kernel mode, continues to manage the device's PnP and power state, but it needs the ability to reach out to its companion to perform tasks that must be performed in IUM.

Although the Secure Driver Framework (SDF) mentioned in Chapter 3 is deprecated, Figure 9-39 shows the architecture of the new UMDF secure companion model, which is still built on top of the same UMDF core framework (Wudfx02000.dll) used in VTL 0 user mode. The latter leverages services provided by the UMDF secure companion host (WUDFCompanionHost.exe) for loading and managing the driver companion, which is distributed through a DLL. The UMDF secure companion host manages the lifetime of the secure companion and encapsulates many UMDF functions that deal specifically with the IUM environment.

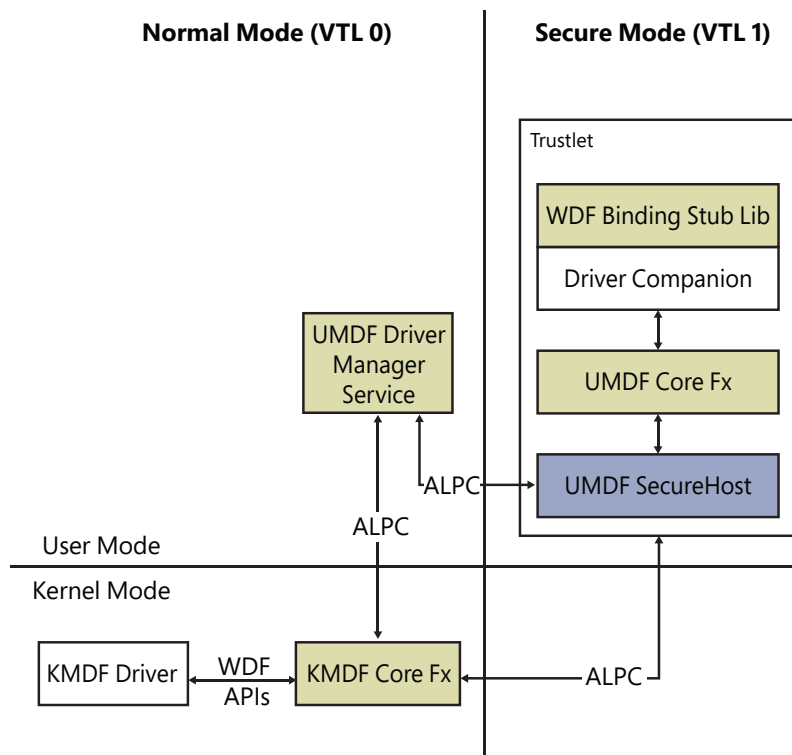

FIGURE 9-39 The WDF driver's secure companion architecture.

A secure companion usually comes associated with the main driver that runs in the VTL 0 kernel. It must be properly signed (including the IUM ECU in the signature, as for every trustlet) and must declare its capabilities in its metadata section. A secure companion has the full ownership of its managed device (this explains why the device is often called *secure device*). A secure device controller by a secure companion supports the following features:

- **Secure DMA** The driver can instruct the device to perform DMA transfer directly in protected VTL 1 memory, which is not accessible to VTL 0. The secure companion can process the data sent or received through the DMA interface and can then transfer part of the data to the VTL 0 driver through the standard KMDF communication interface (ALPC). The *IumGetDmaEnabler* and *IumDmaMapMemory* secure system calls, exposed through *lumbase.dll*, allow the secure companion to map physical DMA memory ranges directly in VTL 1 user mode.
- **Memory mapped IO (MMIO)** The secure companion can request the device to map its accessible MMIO range in VTL 1 (user mode). It can then access the memory-mapped device's registers directly in IUM. *MapSecureIo* and the *ProtectSecureIo* APIs expose this feature.
- **Secure sections** The companion can create (through the *CreateSecureSection* API) and map secure sections, which represent memory that can be shared between trustlets and the main driver running in VTL 0. Furthermore, the secure companion can specify a different type of SLAT protection in case the memory is accessed through the secure device (via DMA or MMIO).

A secure companion can't directly respond to device interrupts, which need to be mapped and managed by the associated kernel mode driver in VTL 0. In the same way, the kernel mode driver still needs to act as the high-level interface for the system and user mode applications by managing all the received IOCTLS. The main driver communicates with its secure companion by sending WDF tasks using the UMDF Task Queue object, which internally uses the ALPC facilities exposed by the WDF framework.

A typical KMDF driver registers its companion via INF directives. WDF automatically starts the driver's companion in the context of the driver's call to *WdfDeviceCreate*—which, for plug and play drivers usually happens in the *AddDevice* callback—by sending an ALPC message to the UMDF driver manager service, which spawns a new *WUDFCompanionHost.exe* trustlet by calling the *NtCreateUserProcess* native API. The UMDF secure companion host then loads the secure companion DLL in its address space. Another ALPC message is sent from the UMDF driver manager to the *WUDFCompanionHost*, with the goal to actually start the secure companion. The *DriverEntry* routine of the companion performs the driver's secure initialization and creates the *WDFDRIVER* object through the classic *WdfDriverCreate* API.

The framework then calls the *AddDevice* callback routine of the companion in VTL 1, which usually creates the companion's device through the new *WdfDeviceCompanionCreate* UMDF API. The latter transfers the execution to the Secure Kernel (through the *IumCreateSecureDevice* secure system call), which creates the new secure device. From this point on, the secure companion has full ownership of its managed device. Usually, the first thing that the companion does after the creation of the secure device is to create the task queue object (*WDFTASKQUEUE*) used to process any incoming tasks delivered by its associated VTL 0 driver. The execution control returns to the kernel mode driver, which can now send new tasks to its secure companion.

This model is also supported by WDM drivers. WDM drivers can use the KMDF's miniport mode to interact with a special filter driver, `WdmCompanionFilter.sys`, which is attached in a lower-level position of the device's stack. The Wdm Companion filter allows WDM drivers to use the task queue object for sending tasks to the secure companion.

VBS-based enclaves

In Chapter 5 of Part 1, we discuss the Software Guard Extension (SGX), a hardware technology that allows the creation of protected memory enclaves, which are secure zones in a process address space where code and data are protected (encrypted) by the hardware from code running outside the enclave. The technology, which was first introduced in the sixth generation Intel Core processors (Skylake), has suffered from some problems that prevented its broad adoption. (Furthermore, AMD released another technology called Secure Encrypted Virtualization, which is not compatible with SGX.)

To overcome these issues, Microsoft released VBS-based enclaves, which are secure enclaves whose isolation guarantees are provided using the VSM infrastructure. Code and data inside of a VBS-based enclave is visible only to the enclave itself (and the VSM Secure Kernel) and is inaccessible to the NT kernel, VTL0 processes, and secure trustlets running in the system.

A secure VBS-based enclave is created by establishing a single virtual address range within a normal process. Code and data are then loaded into the enclave, after which the enclave is entered for the first time by transferring control to its entry point via the Secure Kernel. The Secure Kernel first verifies that all code and data are authentic and are authorized to run inside the enclave by using image signature verification on the enclave image. If the signature checks pass, then the execution control is transferred to the enclave entry point, which has access to all of the enclave's code and data. By default, the system only supports the execution of enclaves that are properly signed. This precludes the possibility that unsigned malware can execute on a system outside the view of anti-malware software, which is incapable of inspecting the contents of any enclave.

During execution, control can transfer back and forth between the enclave and its containing process. Code executing inside of an enclave has access to all data within the virtual address range of the enclave. Furthermore, it has read and write access of the containing unsecure process address space. All memory within the enclave's virtual address range will be inaccessible to the containing process. If multiple enclaves exist within a single host process, each enclave will be able to access only its own memory and the memory that is accessible to the host process.

As for hardware enclaves, when code is running in an enclave, it can obtain a sealed enclave report, which can be used by a third-party entity to validate that the code is running with the isolation guarantees of a VBS enclave, and which can further be used to validate the specific version of code running. This report includes information about the host system, the enclave itself, and all DLLs that may have been loaded into the enclave, as well as information indicating whether the enclave is executing with debugging capabilities enabled.

A VBS-based enclave is distributed as a DLL, which has certain specific characteristics:

- It is signed with an authenticode signature, and the leaf certificate includes a valid EKU that permits the image to be run as an enclave. The root authority that has emitted the digital certificate should be Microsoft, or a third-party signing authority covered by a certificate manifest that's countersigned by Microsoft. This implies that third-party companies could sign and run their own enclaves. Valid digital signature EKUs are the IUM EKU (1.3.6.1.4.1.311.10.3.37) for internal Windows-signed enclaves or the Enclave EKU (1.3.6.1.4.1.311.10.3.42) for all the third-party enclaves.
- It includes an enclave configuration section (represented by an *IMAGE_ENCLAVE_CONFIG* data structure), which describes information about the enclave and which is linked to its image's load configuration data directory.
- It includes the correct Control Flow Guard (CFG) instrumentation.

The enclave's configuration section is important because it includes important information needed to properly run and seal the enclave: the unique family ID and image ID, which are specified by the enclave's author and identify the enclave binary, the secure version number and the enclave's policy information (like the expected virtual size, the maximum number of threads that can run, and the debuggability of the enclave). Furthermore, the enclave's configuration section includes the list of images that may be imported by the enclave, included with their identity information. An enclave's imported module can be identified by a combination of the family ID and image ID, or by a combination of the generated unique ID, which is calculated starting from the hash of the binary, and author ID, which is derived from the certificate used to sign the enclave. (This value expresses the identity of who has constructed the enclave.) The imported module descriptor must also include the minimum secure version number.

The Secure Kernel offers some basic system services to enclaves through the VBS enclave runtime DLL, *VertDll.dll*, which is mapped in the enclave address space. These services include: a limited subset of the standard C runtime library, the ability to allocate or free secure memory within the address range of the enclave, synchronization services, structured exception handling support, basic cryptographic functions, and the ability to seal data.

EXPERIMENT: Dumping the enclave configuration

In this experiment, we use the Microsoft Incremental linker (*link.exe*) included in the Windows SDK and WDK to dump software enclave configuration data. Both packages are downloadable from the web. You can also use the EWDK, which contains all the necessary tools and does not require any installation. It's available at <https://docs.microsoft.com/en-us/windows-hardware/drivers/download-the-wdk>.

Open the Visual Studio Developer Command Prompt through the Cortana search box or by executing the *LaunchBuildEnv.cmd* script file contained in the EWDK's Iso image. We will analyze the configuration data of the System Guard Routine Attestation enclave—which is shown in Figure 9-40 and will be described later in this chapter—with the ***link.exe /dump /loadconfig*** command:

```

C:\> "Vs2017 & WDK Build Env WDKContentRoot: D:\Program Files\Windows Kits\10\"
*****
** Visual Studio 2017 Developer Command Prompt v15.0
** Copyright (c) 2017 Microsoft Corporation
*****
D:\>c:
C:\>md test
C:\>copy c:\Windows\system32\SgrmEnclave_secure.dll c:\test
        1 file(s) copied.
C:\>cd test
C:\test>link /dump /loadconfig SgrmEnclave_secure.dll > SgrmEnclave_secure_loadconfig.txt
C:\test>_

```

The command's output is large. So, in the example shown in the preceding figure, we have redirected it to the `SgrmEnclave_secure_loadconfig.txt` file. If you open the new output file, you see that the binary image contains a CFG table and includes a valid enclave configuration pointer, which targets the following data:

Enclave Configuration

```

00000050 size
0000004C minimum required config size
00000000 policy flags
00000003 number of enclave import descriptors
0004FA04 RVA to enclave import descriptors
00000050 size of an enclave import descriptor
00000001 image version
00000001 security version
0000000010000000 enclave size
00000008 number of threads
00000001 enclave flags

```

```

family ID : B1 35 7C 2B 69 9F 47 F9 BB C9 4F 44 F2 54 DB 9D
image ID  : 24 56 46 36 CD 4A D8 86 A2 F4 EC 25 A9 72 02

```

ucrtbase_enclave.dll

```

0 minimum security version
0 reserved

```

```

match type : image ID
family ID  : 00 00 00 00 00 00 00 00 00 00 00 00 00 00 00 00
image ID   : F0 3C CD A7 E8 7B 46 EB AA E7 1F 13 D5 CD DE 5D
unique/author ID : 00 00 00 00 00 00 00 00 00 00 00 00 00 00 00 00
              00 00 00 00 00 00 00 00 00 00 00 00 00 00 00 00

```

bcrypt.dll

```

0 minimum security version
0 reserved

match type : image ID
family ID : 00 00 00 00 00 00 00 00 00 00 00 00 00 00 00 00
image ID : 20 27 BD 68 75 59 49 B7 BE 06 34 50 E2 16 D7 ED
unique/author ID : 00 00 00 00 00 00 00 00 00 00 00 00 00 00 00 00
                00 00 00 00 00 00 00 00 00 00 00 00 00 00 00 00
...

```

The configuration section contains the binary image's enclave data (like the family ID, image ID, and security version number) and the import descriptor array, which communicates to the Secure Kernel from which library the main enclave's binary can safely depend on. You can redo the experiment with the `Vertdll.dll` library and with all the binaries imported from the System Guard Routine Attestation enclave.

Enclave lifecycle

In Chapter 5 of Part 1, we discussed the lifecycle of a hardware enclave (SGX-based). The lifecycle of a VBS-based enclave is similar; Microsoft has enhanced the already available enclave APIs to support the new type of VBS-based enclaves.

Step 1: Creation An application creates a VBS-based enclave by specifying the `ENCLAVE_TYPE_VBS` flag to the `CreateEnclave` API. The caller should specify an owner ID, which identifies the owner of the enclave. The enclave creation code, in the same way as for hardware enclaves, ends up calling the `NtCreateEnclave` in the kernel. The latter checks the parameters, copies the passed-in structures, and attaches to the target process in case the enclave is to be created in a different process than the caller's. The `MiCreateEnclave` function allocates an enclave-type VAD describing the enclave virtual memory range and selects a base virtual address if not specified by the caller. The kernel allocates the memory manager's VBS enclave data structure and the per-process enclave hash table, used for fast lookup of the enclave starting by its number. If the enclave is the first created for the process, the system also creates an empty secure process (which acts as a container for the enclaves) in VTL 1 by using the `CREATE_PROCESS` secure call (see the earlier section "Trustlets creation" for further details).

The `CREATE_ENCLAVE` secure call handler in VTL 1 performs the actual work of the enclave creation: it allocates the secure enclave key data structure (`SKMI_ENCLAVE`), sets the reference to the container secure process (which has just been created by the NT kernel), and creates the secure VAD describing the entire enclave virtual address space (the secure VAD contains similar information to its VTL 0 counterpart). This VAD is inserted in the containing process's VAD tree (and not in the enclave itself). An empty virtual address space for the enclave is created in the same way as for its containing process: the page table root is filled by system entries only.

Step 2: Loading modules into the enclave Differently from hardware-based enclaves, the parent process can load only modules into the enclave but not arbitrary data. This will cause each page of the image to be copied into the address space in VTL 1. Each image's page in the VTL 1 enclave will be a *private* copy. At least one module (which acts as the main enclave image) needs to be loaded into the enclave; otherwise, the enclave can't be initialized. After the VBS enclave has been created, an application calls the *LoadEnclaveImage* API, specifying the enclave base address and the name of the module that must be loaded in the enclave. The Windows Loader code (in *Ntdll.dll*) searches the specified DLL name, opens and validates its binary file, and creates a section object that is mapped with read-only access right in the calling process.

After the loader maps the section, it parses the image's import address table with the goal to create a list of the dependent modules (imported, delay loaded, and forwarded). For each found module, the loader checks whether there is enough space in the enclave for mapping it and calculates the correct image base address. As shown in Figure 9-40, which represents the System Guard Runtime Attestation enclave, modules in the enclave are mapped using a top-down strategy. This means that the main image is mapped at the highest possible virtual address, and all the dependent ones are mapped in lower addresses one next to each other. At this stage, for each module, the Windows Loader calls the *NtLoadEnclaveData* kernel API.

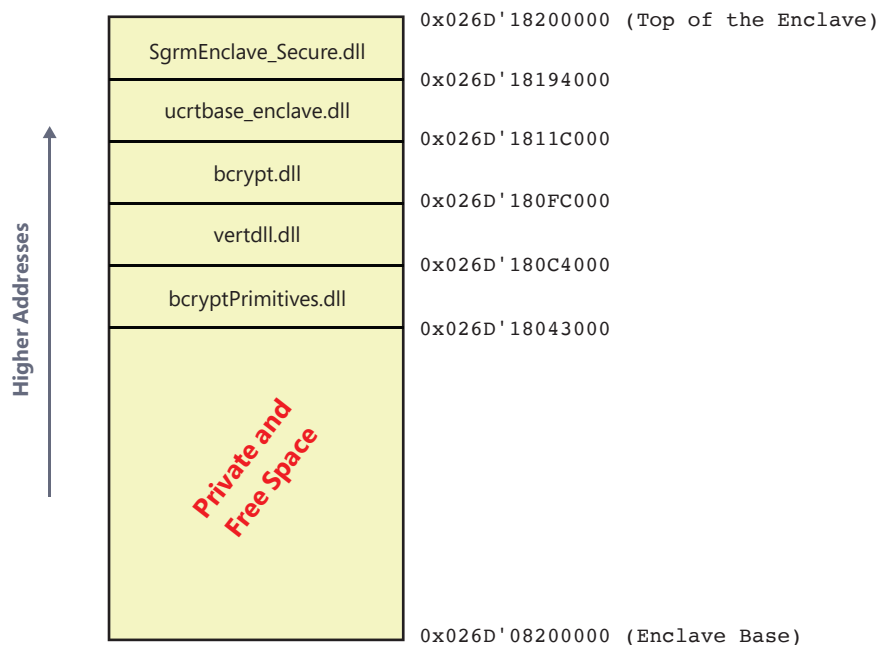

FIGURE 9-40 The System Guard Runtime Attestation secure enclave (note the empty space at the base of the enclave).

For loading the specified image in the VBS enclave, the kernel starts a complex process that allows the shared pages of its section object to be copied in the private pages of the enclave in VTL 1. The *MiMapImageForEnclaveUse* function gets the control area of the section object and validates it through SKCI. If the validation fails, the process is interrupted, and an error is returned to the caller. (All the enclave's modules should be correctly signed as discussed previously.) Otherwise, the system attaches to the secure system process and maps the image's section object in its address space in VTL 0. The shared pages of the module at this time could be valid or invalid; see Chapter 5 of Part 1 for further details. It then commits the virtual address space of the module in the containing process. This creates private VTL 0 paging data structures for demand-zero PTEs, which will be later populated by the Secure Kernel when the image is loaded in VTL 1.

The *LOAD_ENCLAVE_MODULE* secure call handler in VTL 1 obtains the *SECURE_IMAGE* of the new module (created by SKCI) and verifies whether the image is suitable for use in a VBS-based enclave (by verifying the digital signature characteristics). It then attaches to the secure system process in VTL 1 and maps the secure image at the same virtual address previously mapped by the NT kernel. This allows the sharing of the prototype PTEs from VTL 0. The Secure Kernel then creates the secure VAD that describes the module and inserts it into the VTL 1 address space of the enclave. It finally cycles between each module's section prototype PTE. For each nonpresent prototype PTE, it attaches to the secure system process and uses the *GET_PHYSICAL_PAGE* normal call to invoke the NT page fault handler (*MmAccessFault*), which brings in memory the shared page. The Secure Kernel performs a similar process for the private enclave pages, which have been previously committed by the NT kernel in VTL 0 by demand-zero PTEs. The NT page fault handler in this case allocates zeroed pages. The Secure Kernel copies the content of each shared physical page into each new private page and applies the needed private relocations if needed.

The loading of the module in the VBS-based enclave is complete. The Secure Kernel applies the SLAT protection to the private enclave pages (the NT kernel has no access to the image's code and data in the enclave), unmaps the shared section from the secure system process, and yields the execution to the NT kernel. The Loader can now proceed with the next module.

Step 3: Enclave initialization After all the modules have been loaded into the enclave, an application initializes the enclave using the *InitializeEnclave* API, and specifies the maximum number of threads supported by the enclave (which will be bound to threads able to perform enclave calls in the containing process). The Secure Kernel's *INITIALIZE_ENCLAVE* secure call's handler verifies that the policies specified during enclave creation are compatible with the policies expressed in the configuration information of the primary image, verifies that the enclave's platform library is loaded (*Vertdll.dll*), calculates the final 256-bit hash of the enclave (used for generating the enclave sealed report), and creates all the secure enclave threads. When the execution control is returned to the Windows Loader code in VTL 0, the system performs the first enclave call, which executes the initialization code of the platform DLL.

Step 4: Enclave calls (inbound and outbound) After the enclave has been correctly initialized, an application can make an arbitrary number of calls into the enclave. All the callable functions in the enclave need to be exported. An application can call the standard *GetProcAddress* API to get the address of the enclave's function and then use the *CallEnclave* routine for transferring the execution control to the secure enclave. In this scenario, which describes an *inbound call*, the *NtCallEnclave* kernel routine

performs the thread selection algorithm, which binds the calling VTL 0 thread to an enclave thread, according to the following rules:

- If the normal thread was not previously called by the enclave (enclaves support nested calls), then an arbitrary idle enclave thread is selected for execution. In case no idle enclave threads are available, the call blocks until an enclave thread becomes available (if specified by the caller; otherwise the call simply fails).
- In case the normal thread was previously called by the enclave, then the call into the enclave is made on the same enclave thread that issued the previous call to the host.

A list of enclave thread's descriptors is maintained by both the NT and Secure Kernel. When a normal thread is bound to an enclave thread, the enclave thread is inserted in another list, which is called the *bound threads* list. Enclave threads tracked by the latter are currently running and are not available anymore.

After the thread selection algorithm succeeds, the NT kernel emits the *CALLENCLAVE* secure call. The Secure Kernel creates a new stack frame for the enclave and returns to user mode. The first user mode function executed in the context of the enclave is *RtlEnclaveCallDispatcher*. The latter, in case the enclave call was the first one ever emitted, transfers the execution to the initialization routine of the VSM enclave runtime DLL (*Vertdll.dll*), which initializes the CRT, the loader, and all the services provided to the enclave; it finally calls the *DllMain* function of the enclave's main module and of all its dependent images (by specifying a *DLL_PROCESS_ATTACH* reason).

In normal situations, where the enclave platform DLL has been already initialized, the enclave dispatcher invokes the *DllMain* of each module by specifying a *DLL_THREAD_ATTACH* reason, verifies whether the specified address of the target enclave's function is valid, and, if so, finally calls the target function. When the target enclave's routine finishes its execution, it returns to VTL 0 by calling back into the containing process. For doing this, it still relies on the enclave platform DLL, which again calls the *NtCallEnclave* kernel routine. Even though the latter is implemented slightly differently in the Secure Kernel, it adopts a similar strategy for returning to VTL 0. The enclave itself can emit enclave calls for executing some function in the context of the unsecure containing process. In this scenario (which describes an outbound call), the enclave code uses the *CallEnclave* routine and specifies the address of an exported function in the containing process's main module.

Step 5: Termination and destruction When termination of an entire enclave is requested through the *TerminateEnclave* API, all threads executing inside the enclave will be forced to return to VTL 0. Once termination of an enclave is requested, all further calls into the enclave will fail. As threads terminate, their VTL1 thread state (including thread stacks) is destroyed. Once all threads have stopped executing, the enclave can be destroyed. When the enclave is destroyed, all remaining VTL 1 state associated with the enclave is destroyed, too (including the entire enclave address space), and all pages are freed in VTL 0. Finally, the enclave VAD is deleted and all committed enclave memory is freed. Destruction is triggered when the containing process calls *VirtualFree* with the base of the enclave's address range. Destruction is not possible unless the enclave has been terminated or was never initialized.



Note As we have discussed previously, all the memory pages that are mapped into the enclave address space are private. This has multiple implications. No memory pages that belong to the VTL 0 containing process are mapped in the enclave address space, though (and also no VADs describing the containing process's allocation is present). So how can the enclave access all the memory pages of the containing process?

The answer is in the Secure Kernel page fault handler (*SkmmAccessFault*). In its code, the fault handler checks whether the faulting process is an enclave. If it is, the fault handler checks whether the fault happens because the enclave tried to execute some code outside its region. In this case, it raises an access violation error. If the fault is due to a read or write access outside the enclave's address space, the secure page fault handler emits a *GET_PHYSICAL_PAGE* normal service, which results in the VTL 0 access fault handler to be called. The VTL 0 handler checks the containing process VAD tree, obtains the PFN of the page from its PTE—by bringing it in memory if needed—and returns it to VTL 1. At this stage, the Secure Kernel can create the necessary paging structures to map the physical page at the same virtual address (which is guaranteed to be available thanks to the property of the enclave itself) and resumes the execution. The page is now valid in the context of the secure enclave.

Sealing and attestation

VBS-based enclaves, like hardware-based enclaves, support both the sealing and attestation of the data. The term *sealing* refers to the encryption of arbitrary data using one or more encryption keys that aren't visible to the enclave's code but are managed by the Secure Kernel and tied to the machine and to the enclave's identity. Enclaves will never have access to those keys; instead, the Secure Kernel offers services for sealing and unsealing arbitrary contents (through the *EnclaveSealData* and *EnclaveUnsealData* APIs) using an appropriate key designated by the enclave. At the time the data is sealed, a set of parameters is supplied that controls which enclaves are permitted to unseal the data. The following policies are supported:

- **Security version number (SVN) of the Secure Kernel and of the primary image** No enclave can unseal any data that was sealed by a later version of the enclave or the Secure Kernel.
- **Exact code** The data can be unsealed only by an enclave that maps the same identical modules of the enclave that has sealed it. The Secure Kernel verifies the hash of the Unique ID of every image mapped in the enclave to allow a proper unsealing.
- **Same image, family, or author** The data can be unsealed only by an enclave that has the same author ID, family ID, and/or image ID.
- **Runtime policy** The data can be unsealed only if the unsealing enclave has the same debugging policy of the original one (debuggable versus nondebuggable).

It is possible for every enclave to attest to any third party that it is running as a VBS enclave with all the protections offered by the VBS-enclave architecture. An enclave attestation report provides proof that a specific enclave is running under the control of the Secure Kernel. The attestation report contains the identity of all code loaded into the enclave as well as policies controlling how the enclave is executing.

Describing the internal details of the sealing and attestation operations is outside the scope of this book. An enclave can generate an attestation report through the *EnclaveGetAttestationReport* API. The memory buffer returned by the API can be transmitted to another enclave, which can “attest” the integrity of the environment in which the original enclave ran by verifying the attestation report through the *EnclaveVerifyAttestationReport* function.

System Guard runtime attestation

System Guard runtime attestation (SGRA) is an operating system integrity component that leverages the aforementioned VBS-enclaves—together with a remote attestation service component—to provide strong guarantees around its execution environment. This environment is used to assert sensitive system properties at runtime and allows for a relying party to observe violations of security promises that the system provides. The first implementation of this new technology was introduced in Windows 10 April 2018 Update (RS4).

SGRA allows an application to view a statement about the security posture of the device. This statement is composed of three parts:

- A session report, which includes a security level describing the attestable boot-time properties of the device
- A runtime report, which describes the runtime state of the device
- A signed session certificate, which can be used to verify the reports

The SGRA service, *SgrmBroker.exe*, hosts a component (*SgrmEnclave_secure.dll*) that runs in a VTL 1 as a VBS enclave that continually asserts the system for runtime violations of security features. These assertions are surfaced in the runtime report, which can be verified on the backend by a relying part. As the assertions run in a separate domain-of-trust, attacking the contents of the runtime report directly becomes difficult.

SGRA internals

Figure 9-41 shows a high-level overview of the architecture of Windows Defender System Guard runtime attestation, which consists of the following client-side components:

- The VTL-1 assertion engine: *SgrmEnclave_secure.dll*
- A VTL-0 kernel mode agent: *SgrmAgent.sys*
- A VTL-0 WinTCB Protected broker process hosting the assertion engine: *SgrmBroker.exe*
- A VTL-0 LPAC process used by the WinTCBPP broker process to interact with the networking stack: *SgrmLpac.exe*

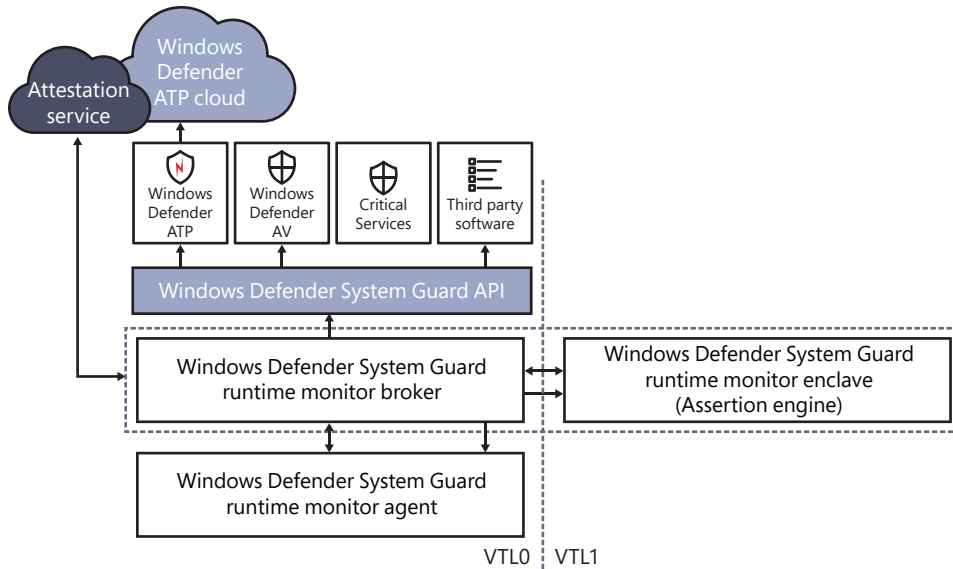

FIGURE 9-41 Windows Defender System Guard runtime attestation’s architecture.

To be able to rapidly respond to threats, SGRA includes a dynamic scripting engine (Lua) forming the core of the assertion mechanism that executes in a VTL 1 enclave—an approach that allows frequent assertion logic updates.

Due to the isolation provided by the VBS enclave, threads executing in VTL 1 are limited in terms of their ability to access VTL 0 NT APIs. Therefore, for the runtime component of SGRA to perform meaningful work, a way of working around the limited VBS enclave API surface is necessary.

An agent-based approach is implemented to expose VTL 0 facilities to the logic running in VTL 1; these facilities are termed *assists* and are serviced by the *SgrmBroker* user mode component or by an agent driver running in VTL 0 kernel mode (*SgrmAgent.sys*). The VTL 1 logic running in the enclave can call out to these VTL 0 components with the goal of requesting assists that provide a range of facilities, including NT kernel synchronize primitives, page mapping capabilities, and so on.

As an example of how this mechanism works, SGRA is capable of allowing the VTL 1 assertion engine to directly read VTL 0–owned physical pages. The enclave requests a mapping of an arbitrary page via an *assist*. The page would then be locked and mapped into the *SgrmBroker* VTL 0 address space (making it resident). As VBS enclaves have direct access to the host process address space, the secure logic can read directly from the mapped virtual addresses. These reads must be synchronized with the VTL 0 kernel itself. The VTL 0 resident broker agent (*SgrmAgent.sys* driver) is also used to perform synchronization.

Assertion logic

As mentioned earlier, SGRA asserts system security properties at runtime. These assertions are executed within the assertion engine hosted in the VBS-based enclave. Signed Lua bytecode describing the assertion logic is provided to the assertion engine during start up.

Assertions are run periodically. When a violation of an asserted property is discovered (that is, when the assertion “fails”), the failure is recorded and stored within the enclave. This failure will be exposed to a relying party in the runtime report that is generated and signed (with the session certificate) within the enclave.

An example of the assertion capabilities provided by SGRA are the asserts surrounding various executive process object attributes—for example, the periodic enumeration of running processes and the assertion of the state of a process’s protection bits that govern protected process policies.

The flow for the assertion engine performing this check can be approximated to the following steps:

1. The assertion engine running within VTL 1 calls into its VTL 0 host process (SgrmBroker) to request that an executive process object be referenced by the kernel.
2. The broker process forwards this request to the kernel mode agent (SgrmAgent), which services the request by obtaining a reference to the requested executive process object.
3. The agent notifies the broker that the request has been serviced and passes any necessary metadata down to the broker.
4. The broker forwards this response to the requesting VTL 1 assertion logic.
5. The logic can then elect to have the physical page backing the referenced executive process object locked and mapped into its accessible address space; this is done by calling out of the enclave using a similar flow as steps 1 through 4.
6. Once the page is mapped, the VTL 1 engine can read it directly and check the executive process object protection bit against its internally held context.
7. The VTL 1 logic again calls out to VTL 0 to unwind the page mapping and kernel object reference.

Reports and trust establishment

A WinRT-based API is exposed to allow relying parties to obtain the SGRA session certificate and the signed session and runtime reports. This API is not public and is available under NDA to vendors that are part of the Microsoft Virus Initiative (note that Microsoft Defender Advanced Threat Protection is currently the only in-box component that interfaces directly with SGRA via this API).

The flow for obtaining a trusted statement from SGRA is as follows:

1. A session is created between the relying party and SGRA. Establishment of the session requires a network connection. The SgrmEnclave assertion engine (running in VTL-1) generates a public-private key pair, and the SgrmBroker protected process retrieves the TCG log and the VBS attestation report, sending them to Microsoft’s System Guard attestation service with the public component of the key generated in the previous step.
2. The attestation service verifies the TCG log (from the TPM) and the VBS attestation report (as proof that the logic is running within a VBS enclave) and generates a session report describing the attested boot time properties of the device. It signs the public key with an SGRA attestation service intermediate key to create a certificate that will be used to verify runtime reports.

3. The session report and the certificate are returned to the relying party. From this point, the relying party can verify the validity of the session report and runtime certificate.
4. Periodically, the relying party can request a runtime report from SGRA using the established session: the SgrmEnclave assertion engine generates a runtime report describing the state of the assertions that have been run. The report will be signed using the paired private key generated during session creation and returned to the relying party (the private key never leaves the enclave).
5. The relying party can verify the validity of the runtime report against the runtime certificate obtained earlier and make a policy decision based on both the contents of the session report (boot-time attested state) and the runtime report (asserted state).

SGRA provides some API that relying parties can use to attest to the state of the device at a point in time. The API returns a runtime report that details the claims that Windows Defender System Guard runtime attestation makes about the security posture of the system. These claims include assertions, which are runtime measurements of sensitive system properties. For example, an app could ask Windows Defender System Guard to measure the security of the system from the hardware-backed enclave and return a report. The details in this report can be used by the app to decide whether it performs a sensitive financial transaction or displays personal information.

As discussed in the previous section, a VBS-based enclave can also expose an enclave attestation report signed by a VBS-specific signing key. If Windows Defender System Guard can obtain proof that the host system is running with VSM active, it can use this proof with a signed session report to ensure that the particular enclave is running. Establishing the trust necessary to guarantee that the runtime report is authentic, therefore, requires the following:

1. Attesting to the boot state of the machine; the OS, hypervisor, and Secure Kernel (SK) binaries must be signed by Microsoft and configured according to a secure policy.
2. Binding trust between the TPM and the health of the hypervisor to allow trust in the Measured Boot Log.
3. Extracting the needed key (VSM IDKs) from the Measured Boot Log and using these to verify the VBS enclave signature (see Chapter 12 for further details).
4. Signing of the public component of an ephemeral key-pair generated within the enclave with a trusted Certificate Authority to issue a session certificate.
5. Signing of the runtime report with the ephemeral private key.

Networking calls between the enclave and the Windows Defender System Guard attestation service are made from VTL 0. However, the design of the attestation protocol ensures that it is resilient against tampering even over untrusted transport mechanisms.

Numerous underlying technologies are required before the chain of trust described earlier can be sufficiently established. To inform a relying party of the level of trust in the runtime report that they can expect on any particular configuration, a security level is assigned to each Windows Defender System Guard attestation service-signed session report. The security level reflects the underlying technologies

enabled on the platform and attributes a level of trust based on the capabilities of the platform. Microsoft is mapping the enablement of various security technologies to security levels and will share this when the API is published for third-party use. The highest level of trust is likely to require the following features, at the very least:

- VBS-capable hardware and OEM configuration.
- Dynamic root-of-trust measurements at boot.
- Secure boot to verify hypervisor, NT, and SK images.
- Secure policy ensuring Hypervisor Enforced Code Integrity (HVCI) and kernel mode code integrity (KMCI), test-signing is disabled, and kernel debugging is disabled.
- The ELAM driver is present.

Conclusion

Windows is able to manage and run multiple virtual machines thanks to the Hyper-V hypervisor and its virtualization stack, which, combined together, support different operating systems running in a VM. Over the years, the two components have evolved to provide more optimizations and advanced features for the VMs, like nested virtualization, multiple schedulers for the virtual processors, different types of virtual hardware support, VMBus, VA-backed VMs, and so on.

Virtualization-based security provides to the root operating system a new level of protection against malware and stealthy rootkits, which are no longer able to steal private and confidential information from the root operating system's memory. The Secure Kernel uses the services supplied by the Windows hypervisor to create a new execution environment (VTL 1) that is protected and not accessible to the software running in the main OS. Furthermore, the Secure Kernel delivers multiple services to the Windows ecosystem that help to maintain a more secure environment.

The Secure Kernel also defines the Isolated User Mode, allowing user mode code to be executed in the new protected environment through trustlets, secure devices, and enclaves. The chapter ended with the analysis of System Guard Runtime Attestation, a component that uses the services exposed by the Secure Kernel to measure the workstation's execution environment and to provide strong guarantees about its integrity.

In the next chapter, we look at the management and diagnostics components of Windows and discuss important mechanisms involved with their infrastructure: the registry, services, Task scheduler, Windows Management Instrumentation (WMI), kernel Event Tracing, and so on.

Management, diagnostics, and tracing

This chapter describes fundamental mechanisms in the Microsoft Windows operating system that are critical to its management and configuration. In particular, we describe the Windows registry, services, the Unified Background process manager, and Windows Management Instrumentation (WMI). The chapter also presents some fundamental components used for diagnosis and tracing purposes like Event Tracing for Windows (ETW), Windows Notification Facility (WNF), and Windows Error Reporting (WER). A discussion on the Windows Global flags and a brief introduction on the kernel and User Shim Engine conclude the chapter.

The registry

The registry plays a key role in the configuration and control of Windows systems. It is the repository for both systemwide and per-user settings. Although most people think of the registry as static data stored on the hard disk, as you'll see in this section, the registry is also a window into various in-memory structures maintained by the Windows executive and kernel.

We're starting by providing you with an overview of the registry structure, a discussion of the data types it supports, and a brief tour of the key information Windows maintains in the registry. Then we look inside the internals of the configuration manager, the executive component responsible for implementing the registry database. Among the topics we cover are the internal on-disk structure of the registry, how Windows retrieves configuration information when an application requests it, and what measures are employed to protect this critical system database.

Viewing and changing the registry

In general, you should never have to edit the registry directly. Application and system settings stored in the registry that require changes should have a corresponding user interface to control their modification. However, as we mention several times in this book, some advanced and debug settings have no editing user interface. Therefore, both graphical user interface (GUI) and command-line tools are included with Windows to enable you to view and modify the registry.

Windows comes with one main GUI tool for editing the registry—Regedit.exe—and several command-line registry tools. Reg.exe, for instance, has the ability to import, export, back up, and

restore keys, as well as to compare, modify, and delete keys and values. It can also set or query flags used in UAC virtualization. Regini.exe, on the other hand, allows you to import registry data based on text files that contain ASCII or Unicode configuration data.

The Windows Driver Kit (WDK) also supplies a redistributable component, Offregs.dll, which hosts the Offline Registry Library. This library allows loading registry hive files (covered in the “Hives” section later in the chapter) in their binary format and applying operations on the files themselves, bypassing the usual logical loading and mapping that Windows requires for registry operations. Its use is primarily to assist in offline registry access, such as for purposes of integrity checking and validation. It can also provide performance benefits if the underlying data is not meant to be visible by the system because the access is done through local file I/O instead of registry system calls.

Registry usage

There are four principal times at which configuration data is read:

- During the initial boot process, the boot loader reads configuration data and the list of boot device drivers to load into memory before initializing the kernel. Because the Boot Configuration Database (BCD) is really stored in a registry hive, one could argue that registry access happens even earlier, when the Boot Manager displays the list of operating systems.
- During the kernel boot process, the kernel reads settings that specify which device drivers to load and how various system elements—such as the memory manager and process manager—configure themselves and tune system behavior.
- During logon, Explorer and other Windows components read per-user preferences from the registry, including network drive-letter mappings, desktop wallpaper, screen saver, menu behavior, icon placement, and, perhaps most importantly, which startup programs to launch and which files were most recently accessed.
- During their startup, applications read systemwide settings, such as a list of optionally installed components and licensing data, as well as per-user settings that might include menu and toolbar placement and a list of most-recently accessed documents.

However, the registry can be read at other times as well, such as in response to a modification of a registry value or key. Although the registry provides asynchronous callbacks that are the preferred way to receive change notifications, some applications constantly monitor their configuration settings in the registry through polling and automatically take updated settings into account. In general, however, on an idle system there should be no registry activity and such applications violate best practices. (Process Monitor, from Sysinternals, is a great tool for tracking down such activity and the applications at fault.)

The registry is commonly modified in the following cases:

- Although not a modification, the registry’s initial structure and many default settings are defined by a prototype version of the registry that ships on the Windows setup media that is copied onto a new installation.

- Application setup utilities create default application settings and settings that reflect installation configuration choices.
- During the installation of a device driver, the Plug and Play system creates settings in the registry that tell the I/O manager how to start the driver and creates other settings that configure the driver's operation. (See Chapter 6, "I/O system," in Part 1 for more information on how device drivers are installed.)
- When you change application or system settings through user interfaces, the changes are often stored in the registry.

Registry data types

The registry is a database whose structure is similar to that of a disk volume. The registry contains *keys*, which are similar to a disk's directories, and *values*, which are comparable to files on a disk. A key is a container that can consist of other keys (subkeys) or values. Values, on the other hand, store data. Top-level keys are root keys. Throughout this section, we'll use the words *subkey* and *key* interchangeably.

Both keys and values borrow their naming convention from the file system. Thus, you can uniquely identify a value with the name mark, which is stored in a key called *trade*, with the name *trade\mark*. One exception to this naming scheme is each key's unnamed value. Regedit displays the unnamed value as (Default).

Values store different kinds of data and can be one of the 12 types listed in Table 10-1. The majority of registry values are REG_DWORD, REG_BINARY, or REG_SZ. Values of type REG_DWORD can store numbers or Booleans (true/false values); REG_BINARY values can store numbers larger than 32 bits or raw data such as encrypted passwords; REG_SZ values store strings (Unicode, of course) that can represent elements such as names, file names, paths, and types.

TABLE 10-1 Registry value types

Value Type	Description
REG_NONE	No value type
REG_SZ	Fixed-length Unicode string
REG_EXPAND_SZ	Variable-length Unicode string that can have embedded environment variables
REG_BINARY	Arbitrary-length binary data
REG_DWORD	32-bit number
REG_DWORD_BIG_ENDIAN	32-bit number, with high byte first
REG_LINK	Unicode symbolic link
REG_MULTI_SZ	Array of Unicode NULL-terminated strings
REG_RESOURCE_LIST	Hardware resource description
REG_FULL_RESOURCE_DESCRIPTOR	Hardware resource description
REG_RESOURCE_REQUIREMENTS_LIST	Resource requirements
REG_QWORD	64-bit number

The REG_LINK type is particularly interesting because it lets a key transparently point to another key. When you traverse the registry through a link, the path searching continues at the target of the link. For example, if \Root1\Link has a REG_LINK value of \Root2\RegKey and *RegKey* contains the value *RegValue*, two paths identify *RegValue*: \Root1\Link\RegValue and \Root2\RegKey\RegValue. As explained in the next section, Windows prominently uses registry links: three of the six registry root keys are just links to subkeys within the three nonlink root keys.

Registry logical structure

You can chart the organization of the registry via the data stored within it. There are nine root keys (and you can't add new root keys or delete existing ones) that store information, as shown in Table 10-2.

TABLE 10-2 The nine root keys

Root Key	Description
HKEY_CURRENT_USER	Stores data associated with the currently logged-on user
HKEY_CURRENT_USER_LOCAL_SETTINGS	Stores data associated with the currently logged-on user that are local to the machine and are excluded from a roaming user profile
HKEY_USERS	Stores information about all the accounts on the machine
HKEY_CLASSES_ROOT	Stores file association and Component Object Model (COM) object registration information
HKEY_LOCAL_MACHINE	Stores system-related information
HKEY_PERFORMANCE_DATA	Stores performance information
HKEY_PERFORMANCE_NLSTEXT	Stores text strings that describe performance counters in the local language of the area in which the computer system is running
HKEY_PERFORMANCE_TEXT	Stores text strings that describe performance counters in US English.
HKEY_CURRENT_CONFIG	Stores some information about the current hardware profile (deprecated)

Why do root-key names begin with an H? Because the root-key names represent Windows handles (H) to keys (KEY). As mentioned in Chapter 1, “Concepts and tools” of Part 1, HKLM is an abbreviation used for HKEY_LOCAL_MACHINE. Table 10-3 lists all the root keys and their abbreviations. The following sections explain in detail the contents and purpose of each of these root keys.

TABLE 10-3 Registry root keys

Root Key	Abbreviation	Description	Link
HKEY_CURRENT_USER	HKCU	Points to the user profile of the currently logged-on user	Subkey under HKEY_USERS corresponding to currently logged-on user
HKEY_CURRENT_USER_LOCAL_SETTINGS	HKCULS	Points to the local settings of the currently logged-on user	Link to HKCU\Software\Classes\Local Settings
HKEY_USERS	HKU	Contains subkeys for all loaded user profiles	Not a link

Root Key	Abbreviation	Description	Link
HKEY_CLASSES_ROOT	HKCR	Contains file association and COM registration information	Not a direct link, but rather a merged view of HKLM\SOFTWARE\Classes and HKEY_USERS\<SID>\SOFTWARE\Classes
HKEY_LOCAL_MACHINE	HKLM	Global settings for the machine	Not a link
HKEY_CURRENT_CONFIG	HKCC	Current hardware profile	HKLM\SYSTEM\CurrentControlSet\Hardware Profiles\Current
HKEY_PERFORMANCE_DATA	HKPD	Performance counters	Not a link
HKEY_PERFORMANCE_NLSTEXT	HKPNT	Performance counters text strings	Not a link
HKEY_PERFORMANCE_TEXT	HKPT	Performance counters text strings in US English	Not a link

HKEY_CURRENT_USER

The HKCU root key contains data regarding the preferences and software configuration of the locally logged-on user. It points to the currently logged-on user's user profile, located on the hard disk at \Users\<username>\Ntuser.dat. (See the section "Registry internals" later in this chapter to find out how root keys are mapped to files on the hard disk.) Whenever a user profile is loaded (such as at logon time or when a service process runs under the context of a specific username), HKCU is created to map to the user's key under HKEY_USERS (so if multiple users are logged on in the system, each user would see a different HKCU). Table 10-4 lists some of the subkeys under HKCU.

TABLE 10-4 HKEY_CURRENT_USER subkeys

Subkey	Description
AppEvents	Sound/event associations
Console	Command window settings (for example, width, height, and colors)
Control Panel	Screen saver, desktop scheme, keyboard, and mouse settings, as well as accessibility and regional settings
Environment	Environment variable definitions
EUDC	Information on end-user defined characters
Keyboard Layout	Keyboard layout setting (for example, United States or United Kingdom)
Network	Network drive mappings and settings
Printers	Printer connection settings
Software	User-specific software preferences
Volatile Environment	Volatile environment variable definitions

HKEY_USERS

HKU contains a subkey for each loaded user profile and user class registration database on the system. It also contains a subkey named HKU\DEFAULT that is linked to the profile for the system (which is used by processes running under the local system account and is described in more detail in the section “Services” later in this chapter). This is the profile used by Winlogon, for example, so that changes to the desktop background settings in that profile will be implemented on the logon screen. When a user logs on to a system for the first time and her account does not depend on a roaming domain profile (that is, the user’s profile is obtained from a central network location at the direction of a domain controller), the system creates a profile for her account based on the profile stored in %SystemDrive%\Users\Default.

The location under which the system stores profiles is defined by the registry value HKLM\Software\Microsoft\Windows NT\CurrentVersion\ProfileList\ProfilesDirectory, which is by default set to %SystemDrive%\Users. The *ProfileList* key also stores the list of profiles present on a system. Information for each profile resides under a subkey that has a name reflecting the security identifier (SID) of the account to which the profile corresponds. (See Chapter 7, “Security,” of Part 1 for more information on SIDs.) Data stored in a profile’s key includes the time of the last load of the profile in the *LocalProfileLoadTimeLow* value, the binary representation of the account SID in the *Sid* value, and the path to the profile’s on-disk hive (Ntuser.dat file, described later in this chapter in the “Hives” section) in the directory given by the *ProfileImagePath* value. Windows shows profiles stored on a system in the User Profiles management dialog box, shown in Figure 10-1, which you access by clicking **Configure Advanced User Profile Properties** in the User Accounts Control Panel applet.

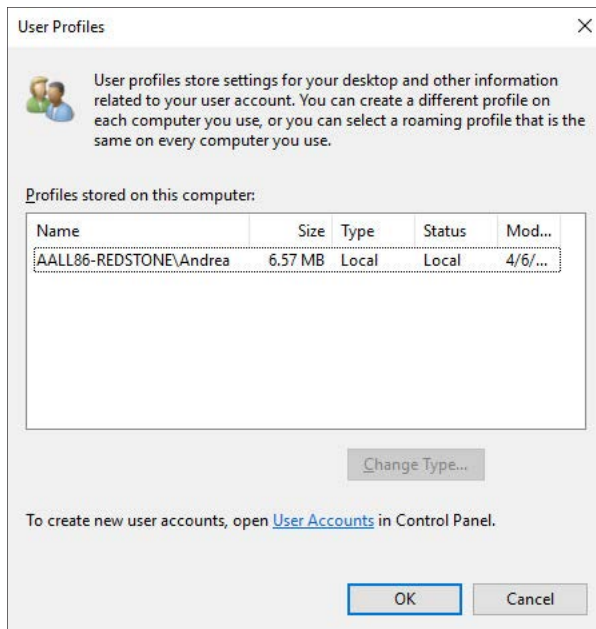
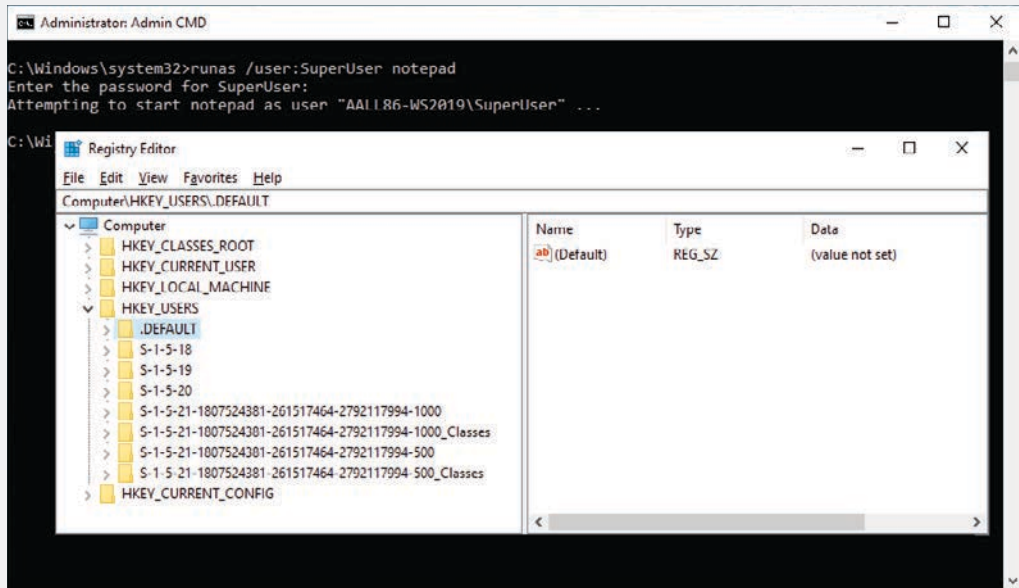

FIGURE 10-1 The User Profiles management dialog box.

EXPERIMENT: Watching profile loading and unloading

You can see a profile load into the registry and then unload by using the **Runas** command to launch a process in an account that's not currently logged on to the machine. While the new process is running, run Regedit and note the loaded profile key under HKEY_USERS. After terminating the process, perform a refresh in Regedit by pressing the **F5** key, and the profile should no longer be present.



HKEY_CLASSES_ROOT

HKCR consists of three types of information: file extension associations, COM class registrations, and the virtualized registry root for User Account Control (UAC). (See Chapter 7 of Part 1 for more information on UAC.) A key exists for every registered file name extension. Most keys contain a REG_SZ value that points to another key in HKCR containing the association information for the class of files that extension represents.

For example, HKCR\.xls would point to information on Microsoft Office Excel files. For example, the default value contains "Excel.Sheet.8" that is used to instantiate the Excel COM object. Other keys contain configuration details for all COM objects registered on the system. The UAC virtualized registry is located in the *VirtualStore* key, which is not related to the other kinds of data stored in HKCR.

The data under HKEY_CLASSES_ROOT comes from two sources:

- The per-user class registration data in HKCU\SOFTWARE\Classes (mapped to the file on hard disk \Users\\AppData\Local\Microsoft\Windows\Usrclass.dat)
- Systemwide class registration data in HKLM\SOFTWARE\Classes

There is a separation of per-user registration data from systemwide registration data so that roaming profiles can contain customizations. Nonprivileged users and applications can read systemwide data and can add new keys and values to systemwide data (which are mirrored in their per-user data), but they can only modify existing keys and values in their private data. It also closes a security hole: a nonprivileged user cannot change or delete keys in the systemwide version HKEY_CLASSES_ROOT; thus, it cannot affect the operation of applications on the system.

HKEY_LOCAL_MACHINE

HKLM is the root key that contains all the systemwide configuration subkeys: BCD00000000, COMPONENTS (loaded dynamically as needed), HARDWARE, SAM, SECURITY, SOFTWARE, and SYSTEM.

The HKLM\BCD00000000 subkey contains the Boot Configuration Database (BCD) information loaded as a registry hive. This database replaces the Boot.ini file that was used before Windows Vista and adds greater flexibility and isolation of per-installation boot configuration data. The BCD00000000 subkey is backed by the hidden BCD file, which, on UEFI systems, is located in \EFI\Microsoft\Boot. (For more information on the BCD, see Chapter 12, "Startup and shutdown").

Each entry in the BCD, such as a Windows installation or the command-line settings for the installation, is stored in the Objects subkey, either as an object referenced by a GUID (in the case of a boot entry) or as a numeric subkey called an *element*. Most of these raw elements are documented in the BCD reference in Microsoft Docs and define various command-line settings or boot parameters. The value associated with each element subkey corresponds to the value for its respective command-line flag or boot parameter.

The BCDEdit command-line utility allows you to modify the BCD using symbolic names for the elements and objects. It also provides extensive help for all the boot options available. A registry hive can be opened remotely as well as imported from a hive file: you can modify or read the BCD of a remote computer by using the Registry Editor. The following experiment shows you how to enable kernel debugging by using the Registry Editor.

EXPERIMENT: Remote BCD editing

Although you can modify offline BCD stores by using the **bcdedit /store** command, in this experiment you will enable debugging through editing the BCD store inside the registry. For the purposes of this example, you edit the local copy of the BCD, but the point of this technique is that it can be used on any machine's BCD hive. Follow these steps to add the **/DEBUG** command-line flag:

1. Open the Registry Editor and then navigate to the HKLM\BCD00000000 key. Expand every subkey so that the numerical identifiers of each Elements key are fully visible.

- Identify the boot entry for your Windows installation by locating the *Description* with a *Type* value of 0x12000003, and then select the 12000004 key in the Elements tree. In the *Element* value of that subkey, you should find the name of your version of Windows, such as Windows 10. In recent systems, you may have more than one Windows installation or various boot applications, like the Windows Recovery Environment or Windows Resume Application. In those cases, you may need to check the 22000002 Elements subkey, which contains the path, such as \Windows.
- Now that you've found the correct GUID for your Windows installation, create a new subkey under the *Elements* subkey for that GUID and name it 0x260000a0. If this subkey already exists, simply navigate to it. The found GUID should correspond to the **identifier** value under the **Windows Boot Loader** section shown by the `bcdedit /v` command (you can use the `/store` command-line option to inspect an offline store file).
- If you had to create the subkey, now create a binary value called **Element** inside it.
- Edit the value and set it to 1. This will enable kernel-mode debugging. Here's what these changes should look like:

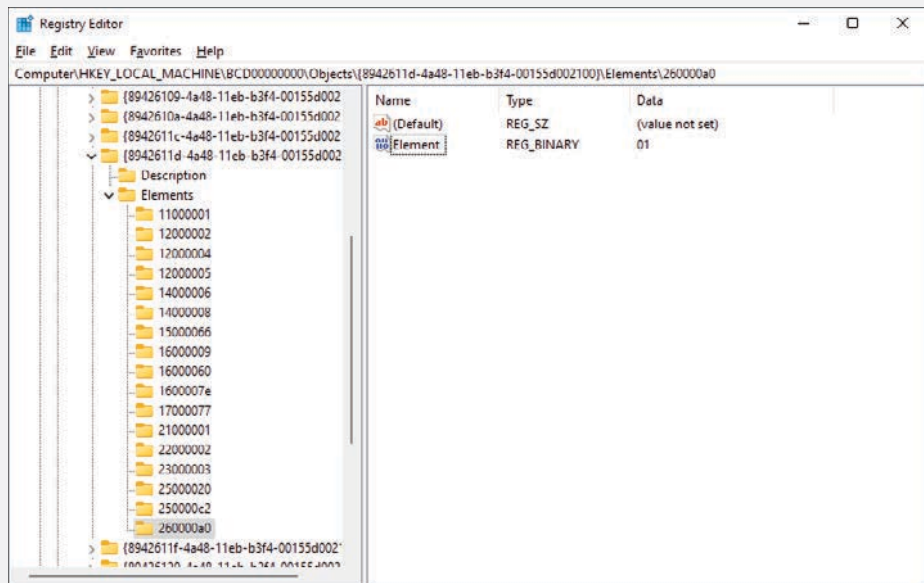

Note The 0x12000004 ID corresponds to *BcdLibraryString_ApplicationPath*, whereas the 0x22000002 ID corresponds to *BcdOSLoaderString_SystemRoot*. Finally, the ID you added, 0x260000a0, corresponds to *BcdOSLoaderBoolean_KernelDebuggerEnabled*. These values are documented in the BCD reference in Microsoft Docs.

The HKLM\COMPONENTS subkey contains information pertinent to the Component Based Servicing (CBS) stack. This stack contains various files and resources that are part of a Windows installation image (used by the Automated Installation Kit or the OEM Preinstallation Kit) or an active installation. The CBS APIs that exist for servicing purposes use the information located in this key to identify installed components and their configuration information. This information is used whenever components are installed, updated, or removed either individually (called *units*) or in groups (called *packages*). To optimize system resources, because this key can get quite large, it is only dynamically loaded and unloaded as needed if the CBS stack is servicing a request. This key is backed by the COMPONENTS hive file located in \Windows\system32\config.

The HKLM\HARDWARE subkey maintains descriptions of the system's legacy hardware and some hardware device-to-driver mappings. On a modern system, only a few peripherals—such as keyboard, mouse, and ACPI BIOS data—are likely to be found here. The Device Manager tool lets you view registry hardware information that it obtains by simply reading values out of the HARDWARE key (although it primarily uses the HKLM\SYSTEM\CurrentControlSet\Enum tree).

HKLM\SAM holds local account and group information, such as user passwords, group definitions, and domain associations. Windows Server systems operating as domain controllers store domain accounts and groups in Active Directory, a database that stores domainwide settings and information. (Active Directory isn't described in this book.) By default, the security descriptor on the SAM key is configured so that even the administrator account doesn't have access.

HKLM\SECURITY stores systemwide security policies and user-rights assignments. HKLM\SAM is linked into the *SECURITY* subkey under HKLM\SECURITY\SAM. By default, you can't view the contents of HKLM\SECURITY or HKLM\SAM because the security settings of those keys allow access only by the System account. (System accounts are discussed in greater detail later in this chapter.) You can change the security descriptor to allow read access to administrators, or you can use PsExec to run Regedit in the local system account if you want to peer inside. However, that glimpse won't be very revealing because the data is undocumented and the passwords are encrypted with one-way mapping—that is, you can't determine a password from its encrypted form. The *SAM* and *SECURITY* subkeys are backed by the SAM and SECURITY hive files located in the \Windows\system32\config path of the boot partition.

HKLM\SOFTWARE is where Windows stores systemwide configuration information not needed to boot the system. Also, third-party applications store their systemwide settings here, such as paths to application files and directories and licensing and expiration date information.

HKLM\SYSTEM contains the systemwide configuration information needed to boot the system, such as which device drivers to load and which services to start. The key is backed by the SYSTEM hive file located in \Windows\system32\config. The Windows Loader uses registry services provided by the Boot Library for being able to read and navigate through the SYSTEM hive.

HKEY_CURRENT_CONFIG

HKEY_CURRENT_CONFIG is just a link to the current hardware profile, stored under HKLM\SYSTEM\CurrentControlSet\Hardware Profiles\Current. Hardware profiles are no longer supported in Windows, but the key still exists to support legacy applications that might depend on its presence.

HKEY_PERFORMANCE_DATA and HKEY_PERFORMANCE_TEXT

The registry is the mechanism used to access performance counter values on Windows, whether those are from operating system components or server applications. One of the side benefits of providing access to the performance counters via the registry is that remote performance monitoring works “for free” because the registry is easily accessible remotely through the normal registry APIs.

You can access the registry performance counter information directly by opening a special key named *HKEY_PERFORMANCE_DATA* and querying values beneath it. You won’t find this key by looking in the Registry Editor; this key is available only programmatically through the Windows registry functions, such as *RegQueryValueEx*. Performance information isn’t actually stored in the registry; the registry functions redirect access under this key to live performance information obtained from performance data providers.

The *HKEY_PERFORMANCE_TEXT* is another special key used to obtain performance counter information (usually name and description). You can obtain the name of any performance counter by querying data from the special *Counter* registry value. The *Help* special registry value yields all the counters description instead. The information returned by the special key are in US English. The *HKEY_PERFORMANCE_NLSTEXT* retrieves performance counters names and descriptions in the language in which the OS runs.

You can also access performance counter information by using the Performance Data Helper (PDH) functions available through the Performance Data Helper API (Pdh.dll). Figure 10-2 shows the components involved in accessing performance counter information.

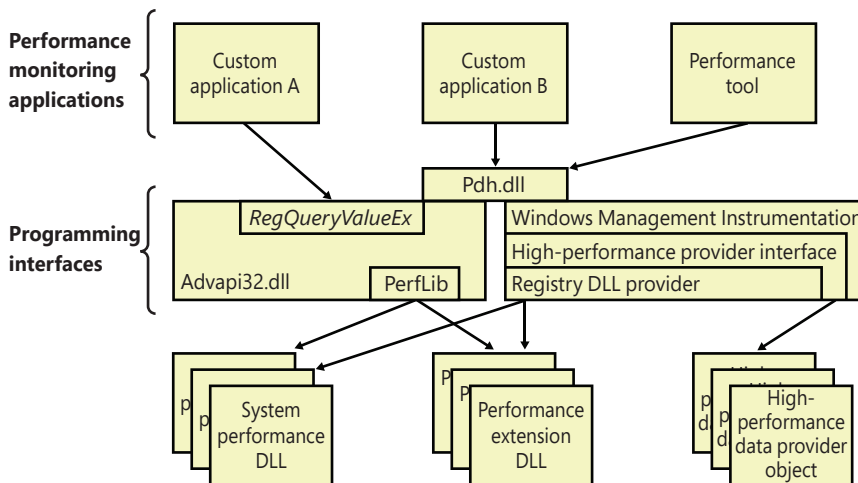

FIGURE 10-2 Registry performance counter architecture.

As shown in Figure 10-2, this registry key is abstracted by the Performance Library (Perflib), which is statically linked in Advapi32.dll. The Windows kernel has no knowledge about the *HKEY_PERFORMANCE_DATA* registry key, which explains why it is not shown in the Registry Editor.

Application hives

Applications are normally able to read and write data from the global registry. When an application opens a registry key, the Windows kernel performs an access check verification against the access token of its process (or thread in case the thread is impersonating; see Chapter 7 in Part 1 for more details) and the ACL that a particular key contains. An application is also able to load and save registry hives by using the *RegSaveKeyEx* and *RegLoadKeyEx* APIs. In those scenarios, the application operates on data that other processes running at a higher or same privilege level can interfere with. Furthermore, for loading and saving hives, the application needs to enable the Backup and Restore privileges. The two privileges are granted only to processes that run with an administrative account.

Clearly this was a limitation for most applications that want to access a private repository for storing their own settings. Windows 7 has introduced the concept of application hives. An application hive is a standard hive file (which is linked to the proper log files) that can be mounted visible only to the application that requested it. A developer can create a base hive file by using the *RegSaveKeyEx* API (which exports the content of a regular registry key in an hive file). The application can then mount the hive privately using the *RegLoadAppKey* function (specifying the *REG_PROCESS_APPKEY* flag prevents other applications from accessing the same hive). Internally, the function performs the following operations:

1. Creates a random GUID and assigns it to a private namespace, in the form of `\Registry\A\<Random Guid>`. (`\Registry` forms the NT kernel registry namespace, described in the “The registry namespace and operation” section later in this chapter.)
2. Converts the DOS path of the specified hive file name in NT format and calls the *NtLoadKeyEx* native API with the proper set of parameters.

The *NtLoadKeyEx* function calls the regular registry callbacks. However, when it detects that the hive is an application hive, it uses *CmLoadAppKey* to load it (and its associated log files) in the private namespace, which is not enumerable by any other application and is tied to the lifetime of the calling process. (The hive and log files are still mapped in the “registry process,” though. The registry process will be described in the “Startup and registry process” section later in this chapter.) The application can use standard registry APIs to read and write its own private settings, which will be stored in the application hive. The hive will be automatically unloaded when the application exits or when the last handle to the key is closed.

Application hives are used by different Windows components, like the Application Compatibility telemetry agent (*CompatTelRunner.exe*) and the Modern Application Model. Universal Windows Platform (UWP) applications use application hives for storing information of WinRT classes that can be instantiated and are private for the application. The hive is stored in a file called *ActivationStore.dat* and is consumed primarily by the Activation Manager when an application is launched (or more precisely, is “activated”). The Background Infrastructure component of the Modern Application Model uses the data stored in the hive for storing background tasks information. In that way, when a background task timer elapses, it knows exactly in which application library the task’s code resides (and the activation type and threading model).

Furthermore, the modern application stack provides to UWP developers the concept of Application Data containers, which can be used for storing settings that can be local to the device in which the

application runs (in this case, the data container is called local) or can be automatically shared between all the user's devices that the application is installed on. Both kinds of containers are implemented in the Windows.Storage.ApplicationData.dll WinRT library, which uses an application hive, local to the application (the backing file is called settings.dat), to store the settings created by the UWP application.

Both the settings.dat and the ActivationStore.dat hive files are created by the Modern Application Model's Deployment process (at app-installation time), which is covered extensively in Chapter 8, "System mechanisms," (with a general discussion of packaged applications). The Application Data containers are documented at <https://docs.microsoft.com/en-us/windows/uwp/get-started/settings-learning-track>.

Transactional Registry (TxR)

Thanks to the Kernel Transaction Manager (KTM; for more information see the section about the KTM in Chapter 8), developers have access to a straightforward API that allows them to implement robust error-recovery capabilities when performing registry operations, which can be linked with nonregistry operations, such as file or database operations.

Three APIs support transactional modification of the registry: *RegCreateKeyTransacted*, *RegOpenKeyTransacted*, and *RegDeleteKeyTransacted*. These new routines take the same parameters as their nontransacted analogs except that a new transaction handle parameter is added. A developer supplies this handle after calling the KTM function *CreateTransaction*.

After a transacted create or open operation, all subsequent registry operations—such as creating, deleting, or modifying values inside the key—will also be transacted. However, operations on the subkeys of a transacted key will not be automatically transacted, which is why the third API, *RegDeleteKeyTransacted* exists. It allows the transacted deletion of subkeys, which *RegDeleteKeyEx* would not normally do.

Data for these transacted operations is written to log files using the common logging file system (CLFS) services, similar to other KTM operations. Until the transaction is committed or rolled back (both of which might happen programmatically or as a result of a power failure or system crash, depending on the state of the transaction), the keys, values, and other registry modifications performed with the transaction handle will not be visible to external applications through the nontransacted APIs. Also, transactions are isolated from each other; modifications made inside one transaction will not be visible from inside other transactions or outside the transaction until the transaction is committed.



Note A nontransactional writer will abort a transaction in case of conflict—for example, if a value was created inside a transaction and later, while the transaction is still active, a nontransactional writer tries to create a value under the same key. The nontransactional operation will succeed, and all operations in the conflicting transaction will be aborted.

The isolation level (the "I" in ACID) implemented by TxR resource managers is read-commit, which means that changes become available to other readers (transacted or not) immediately after being committed. This mechanism is important for people who are familiar with transactions in databases,

where the isolation level is predictable-reads (or cursor-stability, as it is called in database literature). With a predictable-reads isolation level, after you read a value inside a transaction, subsequent reads returns the same data. Read-commit does not make this guarantee. One of the consequences is that registry transactions can't be used for "atomic" increment/decrement operations on a registry value.

To make permanent changes to the registry, the application that has been using the transaction handle must call the KTM function *CommitTransaction*. (If the application decides to undo the changes, such as during a failure path, it can call the *RollbackTransaction API*.) The changes are then visible through the regular registry APIs as well.



Note If a transaction handle created with *CreateTransaction* is closed before the transaction is committed (and there are no other handles open to that transaction), the system rolls back that transaction.

Apart from using the CLFS support provided by the KTM, TxR also stores its own internal log files in the %SystemRoot%\System32\Config\Txr folder on the system volume; these files have a .regtrans-ms extension and are hidden by default. There is a global registry resource manager (RM) that services all the hives mounted at boot time. For every hive that is mounted explicitly, an RM is created. For applications that use registry transactions, the creation of an RM is transparent because KTM ensures that all RMs taking part in the same transaction are coordinated in the two-phase commit/abort protocol. For the global registry RM, the CLFS log files are stored, as mentioned earlier, inside System32\Config\Txr. For other hives, they are stored alongside the hive (in the same directory). They are hidden and follow the same naming convention, ending in .regtrans-ms. The log file names are prefixed with the name of the hive to which they correspond.

Monitoring registry activity

Because the system and applications depend so heavily on configuration settings to guide their behavior, system and application failures can result from changing registry data or security. When the system or an application fails to read settings that it assumes it will always be able to access, it might not function properly, display error messages that hide the root cause, or even crash. It's virtually impossible to know what registry keys or values are misconfigured without understanding how the system or the application that's failing is accessing the registry. In such situations, the Process Monitor utility from Windows Sysinternals (<https://docs.microsoft.com/en-us/sysinternals/>) might provide the answer.

Process Monitor lets you monitor registry activity as it occurs. For each registry access, Process Monitor shows you the process that performed the access; the time, type, and result of the access; and the stack of the thread at the moment of the access. This information is useful for seeing how applications and the system rely on the registry, discovering where applications and the system store configuration settings, and troubleshooting problems related to applications having missing registry keys or values. Process Monitor includes advanced filtering and highlighting so that you can zoom in on activity related to specific keys or values or to the activity of particular processes.

Process Monitor internals

Process Monitor relies on a device driver that it extracts from its executable image at runtime before starting it. Its first execution requires that the account running it has the *Load Driver* privilege as well as the *Debug* privilege; subsequent executions in the same boot session require only the *Debug* privilege because, once loaded, the driver remains resident.

EXPERIMENT: Viewing registry activity on an idle system

Because the registry implements the *RegNotifyChangeKey* function that applications can use to request notification of registry changes without polling for them, when you launch Process Monitor on a system that's idle you should not see repetitive accesses to the same registry keys or values. Any such activity identifies a poorly written application that unnecessarily negatively affects a system's overall performance.

Run Process Monitor, make sure that only the **Show Registry Activity** icon is enabled in the toolbar (with the goal to remove noise generated by the File system, network, and processes or threads) and, after several seconds, examine the output log to see whether you can spot polling behavior. Right-click an output line associated with polling and then choose **Process Properties** from the context menu to view details about the process performing the activity.

EXPERIMENT: Using Process Monitor to locate application registry settings

In some troubleshooting scenarios, you might need to determine where in the registry the system or an application stores particular settings. This experiment has you use Process Monitor to discover the location of Notepad's settings. Notepad, like most Windows applications, saves user preferences—such as word-wrap mode, font and font size, and window position—across executions. By having Process Monitor watching when Notepad reads or writes its settings, you can identify the registry key in which the settings are stored. Here are the steps for doing this:

1. Have Notepad save a setting you can easily search for in a Process Monitor trace. You can do this by running Notepad, setting the font to Times New Roman, and then exiting Notepad.
2. Run Process Monitor. Open the filter dialog box and the **Process Name** filter, and type **notepad.exe** as the string to match. Confirm by clicking the **Add** button. This step specifies that Process Monitor will log only activity by the notepad.exe process.
3. Run Notepad again, and after it has launched, stop Process Monitor's event capture by toggling **Capture Events** on the Process Monitor **File** menu.
4. Scroll to the top line of the resultant log and select it.

- Press **Ctrl+F** to open a **Find** dialog box, and search for **times new**. Process Monitor should highlight a line like the one shown in the following screen that represents Notepad reading the font value from the registry. Other operations in the immediate vicinity should relate to other Notepad settings.

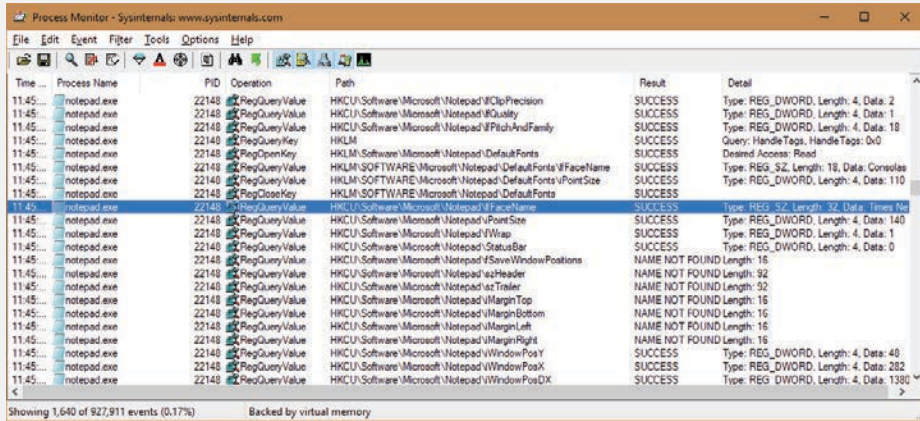

- Right-click the highlighted line and click **Jump To**. Process Monitor starts Regedit (if it's not already running) and causes it to navigate to and select the Notepad-referenced registry value.

Registry internals

This section describes how the configuration manager—the executive subsystem that implements the registry—organizes the registry's on-disk files. We'll examine how the configuration manager manages the registry as applications and other operating system components read and change registry keys and values. We'll also discuss the mechanisms by which the configuration manager tries to ensure that the registry is always in a recoverable state, even if the system crashes while the registry is being modified.

Hives

On disk, the registry isn't simply one large file but rather a set of discrete files called hives. Each hive contains a registry tree, which has a key that serves as the root or starting point of the tree. Subkeys and their values reside beneath the root. You might think that the root keys displayed by the Registry Editor correlate to the root keys in the hives, but such is not the case. Table 10-5 lists registry hives and their on-disk file names. The path names of all hives except for user profiles are coded into the configuration manager. As the configuration manager loads hives, including system profiles, it notes each hive's path in the values under the HKLM\SYSTEM\CurrentControlSet\Control\Hivelist subkey, removing the path if the hive is unloaded. It creates the root keys, linking these hives together to build the registry structure you're familiar with and that the Registry Editor displays.

TABLE 10-5 On-disk files corresponding to paths in the registry

Hive Registry Path	Hive File Path
HKEY_LOCAL_MACHINE\BCD00000000	\EFI\Microsoft\Boot
HKEY_LOCAL_MACHINE\COMPONENTS	%SystemRoot%\System32\Config\Components
HKEY_LOCAL_MACHINE\SYSTEM	%SystemRoot%\System32\Config\System
HKEY_LOCAL_MACHINE\SAM	%SystemRoot%\System32\Config\Sam
HKEY_LOCAL_MACHINE\SECURITY	%SystemRoot%\System32\Config\Security
HKEY_LOCAL_MACHINE\SOFTWARE	%SystemRoot%\System32\Config\Software
HKEY_LOCAL_MACHINE\HARDWARE	Volatile hive
\HKEY_LOCAL_MACHINE\WindowsAppLockerCache	%SystemRoot%\System32\AppLocker\AppCache.dat
HKEY_LOCAL_MACHINE\ELAM	%SystemRoot%\System32\Config\Elam
HKEY_USERS\ <sid account><="" local="" of="" service="" td=""> <td>%SystemRoot%\ServiceProfiles\LocalService\Ntuser.dat</td> </sid>	%SystemRoot%\ServiceProfiles\LocalService\Ntuser.dat
HKEY_USERS\ <sid account><="" network="" of="" service="" td=""> <td>%SystemRoot%\ServiceProfiles\NetworkService\NtUser.dat</td> </sid>	%SystemRoot%\ServiceProfiles\NetworkService\NtUser.dat
HKEY_USERS\ <sid of="" td="" username><=""> <td>\Users\<username>\Ntuser.dat</username></td> </sid>	\Users\ <username>\Ntuser.dat</username>
HKEY_USERS\ <sid of="" td="" username>_classes<=""> <td>\Users\<username>\AppData\Local\Microsoft\Windows\Usrclass.dat</username></td> </sid>	\Users\ <username>\AppData\Local\Microsoft\Windows\Usrclass.dat</username>
HKEY_USERS\DEFAULT	%SystemRoot%\System32\Config\Default
Virtualized HKEY_LOCAL_MACHINE\SOFTWARE	Different paths. Usually \ProgramData\Packages\ <packagefullname>\<usersid>\SystemAppData\Helium\Cache\<randomname>.dat centennial<="" for="" td=""> </randomname>.dat></usersid></packagefullname>
Virtualized HKEY_CURRENT_USER	Different paths. Usually \ProgramData\Packages\ <packagefullname>\<usersid>\SystemAppData\Helium\User.dat for Centennial</usersid></packagefullname>
Virtualized HKEY_LOCAL_MACHINE\SOFTWARE\Classes	Different paths. Usually \ProgramData\Packages\ <packagefullname>\<usersid>\SystemAppData\Helium\UserClasses.dat for Centennial</usersid></packagefullname>

You'll notice that some of the hives listed in Table 10-5 are volatile and don't have associated files. The system creates and manages these hives entirely in memory; the hives are therefore temporary. The system creates volatile hives every time it boots. An example of a volatile hive is the HKLM\HARDWARE hive, which stores information about physical devices and the devices' assigned resources. Resource assignment and hardware detection occur every time the system boots, so not storing this data on disk is logical. You will also notice that the last three entries in the table represent virtualized hives. Starting from Windows 10 Anniversary Update, the NT kernel supports the Virtualized Registry (VReg), with the goal to provide support for Centennial packaged applications, which runs in a Helium container. Every time the user runs a centennial application (like the modern Skype, for example), the system mounts the needed package hives. Centennial applications and the Modern Application Model have been extensively discussed in Chapter 8.

EXPERIMENT: Manually loading and unloading hives

Regedit has the ability to load hives that you can access through its **File** menu. This capability can be useful in troubleshooting scenarios where you want to view or edit a hive from an unbootable system or a backup medium. In this experiment, you'll use Regedit to load a version of the HKLM\SYSTEM hive that Windows Setup creates during the install process.

1. Hives can be loaded only underneath HKLM or HKU, so open Regedit, select HKLM, and choose **Load Hive** from the Regedit **File** menu.
2. Navigate to the %SystemRoot%\System32\Config\RegBack directory in the **Load Hive** dialog box, select **System**, and open it. Some newer systems may not have any file in the RegBack folder. In that case, you can try the same experiment by opening the ELAM hive located in the Config folder. When prompted, type **Test** as the name of the key under which it will load.
3. Open the newly created HKLM\Test key and explore the contents of the hive.
4. Open HKLM\SYSTEM\CurrentControlSet\Control\Hivelist and locate the entry \Registry\Machine\Test, which demonstrates how the configuration manager lists loaded hives in the *Hivelist* key.
5. Select HKLM\Test and then choose Unload Hive from the Regedit **File** menu to unload the hive.

Hive size limits

In some cases, hive sizes are limited. For example, Windows places a limit on the size of the HKLM\SYSTEM hive. It does so because Winload reads the entire HKLM\SYSTEM hive into physical memory near the start of the boot process when virtual memory paging is not enabled. Winload also loads Ntoskrnl and boot device drivers into physical memory, so it must constrain the amount of physical memory assigned to HKLM\SYSTEM. (See Chapter 12 for more information on the role Winload plays during the startup process.) On 32-bit systems, Winload allows the hive to be as large as 400 MB or half the amount of physical memory on the system, whichever is lower. On x64 systems, the lower bound is 2 GB.

Startup and the registry process

Before Windows 8.1, the NT kernel was using paged pool for storing the content of every loaded hive file. Most of the hives loaded in the system remained in memory until the system shutdown (a good example is the SOFTWARE hive, which is loaded by the Session Manager after phase 1 of the System startup is completed and sometimes could be multiple hundreds of megabytes in size). Paged pool memory could be paged out by the balance set manager of the memory manager, if it is not accessed for a certain amount of time (see Chapter 5, "Memory management," in Part 1 for more details). This implies that unused parts of a hive do not remain in the working set for a long time. Committed virtual

memory is backed by the page file and requires the system Commit charge to be increased, reducing the total amount of virtual memory available for other purposes.

To overcome this problem, Windows 10 April 2018 Update (RS4) introduced support for the section-backed registry. At phase 1 of the NT kernel initialization, the Configuration manager startup routine initializes multiple components of the Registry: cache, worker threads, transactions, callbacks support, and so on. It then creates the Key object type, and, before loading the needed hives, it creates the Registry process. The Registry process is a fully-protected (same protection as the SYSTEM process: WinSystem level), minimal process, which the configuration manager uses for performing most of the I/Os on opened registry hives. At initialization time, the configuration manager maps the preloaded hives in the Registry process. The preloaded hives (SYSTEM and ELAM) continue to reside in nonpaged memory, though (which is mapped using kernel addresses). Later in the boot process, the Session Manager loads the Software hive by invoking the *NtInitializeRegistry* system call.

A section object backed by the "SOFTWARE" hive file is created: the configuration manager divides the file in 2-MB chunks and creates a reserved mapping in the Registry process's user-mode address space for each of them (using the *NtMapViewOfSection* native API. Reserved mappings are tracked by valid VADs, but no actual pages are allocated. See Chapter 5 in Part 1 for further details). Each 2-MB view is read-only protected. When the configuration manager wants to read some data from the hive, it accesses the view's pages and produces an access fault, which causes the shared pages to be brought into memory by the memory manager. At that time, the system working set charge is increased, but not the commit charge (the pages are backed by the hive file itself, and not by the page file).

At initialization time, the configuration manager sets the hard-working set limit to the Registry process at 64 MB. This means that in high memory pressure scenarios, it is guaranteed that no more than 64 MB of working set is consumed by the registry. Every time an application or the system uses the APIs to access the registry, the configuration manager attaches to the Registry process address space, performs the needed work, and returns the results. The configuration manager doesn't always need to switch address spaces: when the application wants to access a registry key that is already in the cache (a Key control block already exists), the configuration manager skips the process attach and returns the cached data. The registry process is primarily used for doing I/O on the low-level hive file.

When the system writes or modifies registry keys and values stored in a hive, it performs a copy-on-write operation (by first changing the memory protection of the 2 MB view to *PAGE_WRITECOPY*). Writing to memory marked as copy-on-write creates new private pages and increases the system commit charge. When a registry update is requested, the system immediately writes new entries in the hive's log, but the writing of the actual pages belonging to the primary hive file is deferred. Dirty hive's pages, as for every normal memory page, can be paged out to disk. Those pages are written to the primary hive file when the hive is being unloaded or by the Reconciler: one of the configuration manager's lazy writer threads that runs by default once every hour (the time period is configurable by setting the `HKLM\SYSTEM\CurrentControlSet\Control\Session Manager\Configuration Manager\RegistryLazyReconcileInterval` registry value).

The Reconciler and the Incremental logging are discussed in the "Incremental logging" section later in this chapter.

Registry symbolic links

A special type of key known as a registry symbolic link makes it possible for the configuration manager to link keys to organize the registry. A symbolic link is a key that redirects the configuration manager to another key. Thus, the key HKLM\SAM is a symbolic link to the key at the root of the SAM hive. Symbolic links are created by specifying the `REG_CREATE_LINK` parameter to `RegCreateKey` or `RegCreateKeyEx`. Internally, the configuration manager will create a `REG_LINK` value called `SymbolicLinkValue`, which contains the path to the target key. Because this value is a `REG_LINK` instead of a `REG_SZ`, it will not be visible with Regedit—it is, however, part of the on-disk registry hive.

EXPERIMENT: Looking at hive handles

The configuration manager opens hives by using the kernel handle table (described in Chapter 8) so that it can access hives from any process context. Using the kernel handle table is an efficient alternative to approaches that involve using drivers or executive components to access from the System process only handles that must be protected from user processes. You can start Process Explorer as Administrator to see the hive handles, which will be displayed as being opened in the System process. Select the System process, and then select **Handles** from the **Lower Pane View** menu entry on the **View** menu. Sort by handle type, and scroll until you see the hive files, as shown in the following screen.

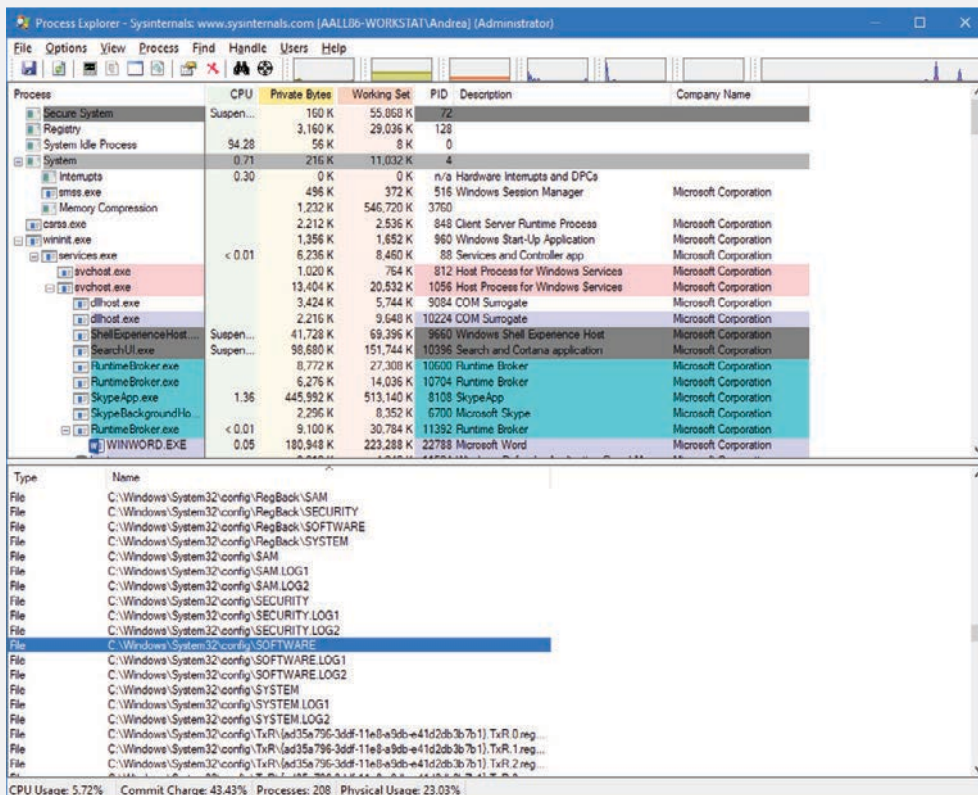

Hive structure

The configuration manager logically divides a hive into allocation units called *blocks* in much the same way that a file system divides a disk into clusters. By definition, the registry block size is 4096 bytes (4 KB). When new data expands a hive, the hive always expands in block-granular increments. The first block of a hive is the base block.

The base block includes global information about the hive, including a signature—*regf*—that identifies the file as a hive, two updated sequence numbers, a time stamp that shows the last time a write operation was initiated on the hive, information on registry repair or recovery performed by Winload, the hive format version number, a checksum, and the hive file's internal file name (for example, `\Device\HarddiskVolume1\WINDOWS\SYSTEM32\CONFIG\SAM`). We'll clarify the significance of the two updated sequence numbers and time stamp when we describe how data is written to a hive file.

The hive format version number specifies the data format within the hive. The configuration manager uses hive format version 1.5, which supports large values (values larger than 1 MB are supported) and improved searching (instead of caching the first four characters of a name, a hash of the entire name is used to reduce collisions). Furthermore, the configuration manager supports differencing hives introduced for container support. Differencing hives uses hive format 1.6.

Windows organizes the registry data that a hive stores in containers called *cells*. A cell can hold a key, a value, a security descriptor, a list of subkeys, or a list of key values. A four-byte character tag at the beginning of a cell's data describes the data's type as a signature. Table 10-6 describes each cell data type in detail. A cell's header is a field that specifies the cell's size as the 1's complement (not present in the `CM_` structures). When a cell joins a hive and the hive must expand to contain the cell, the system creates an allocation unit called a *bin*.

A bin is the size of the new cell rounded up to the next block or page boundary, whichever is higher. The system considers any space between the end of the cell and the end of the bin to be free space that it can allocate to other cells. Bins also have headers that contain a signature, *hbin*, and a field that records the offset into the hive file of the bin and the bin's size.

TABLE 10-6 Cell data types

Data Type	Structure Type	Description
Key cell	CM_KEY_NODE	A cell that contains a registry key, also called a key node. A key cell contains a signature (<i>kn</i> for a key, <i>kl</i> for a link node), the time stamp of the most recent update to the key, the cell index of the key's parent key cell, the cell index of the subkey-list cell that identifies the key's subkeys, a cell index for the key's security descriptor cell, a cell index for a string key that specifies the class name of the key, and the name of the key (for example, <code>CurrentControlSet</code>). It also saves cached information such as the number of subkeys under the key, as well as the size of the largest key, value name, value data, and class name of the subkeys under this key.
Value cell	CM_KEY_VALUE	A cell that contains information about a key's value. This cell includes a signature (<i>kv</i>), the value's type (for example, <code>REG_DWORD</code> or <code>REG_BINARY</code>), and the value's name (for example, <code>Boot-Execute</code>). A value cell also contains the cell index of the cell that contains the value's data.

Data Type	Structure Type	Description
Big Value cell	CM_BIG_DATA	A cell that represents a registry value bigger than 16 kB. For this kind of cell type, the cell content is an array of cell indexes each pointing to a 16-kB cell, which contains a chunk of the registry value.
Subkey-list cell	CM_KEY_INDEX	A cell composed of a list of cell indexes for key cells that are all subkeys of a common parent key.
Value-list cell	CM_KEY_INDEX	A cell composed of a list of cell indexes for value cells that are all values of a common parent key.
Security-descriptor cell	CM_KEY_SECURITY	A cell that contains a security descriptor. Security-descriptor cells include a signature (ks) at the head of the cell and a reference count that records the number of key nodes that share the security descriptor. Multiple key cells can share security-descriptor cells.

By using bins instead of cells, to track active parts of the registry, Windows minimizes some management chores. For example, the system usually allocates and deallocates bins less frequently than it does cells, which lets the configuration manager manage memory more efficiently. When the configuration manager reads a registry hive into memory, it reads the whole hive, including empty bins, but it can choose to discard them later. When the system adds and deletes cells in a hive, the hive can contain empty bins interspersed with active bins. This situation is similar to disk fragmentation, which occurs when the system creates and deletes files on the disk. When a bin becomes empty, the configuration manager joins to the empty bin any adjacent empty bins to form as large a contiguous empty bin as possible. The configuration manager also joins adjacent deleted cells to form larger free cells. (The configuration manager shrinks a hive only when bins at the end of the hive become free. You can compact the registry by backing it up and restoring it using the Windows *RegSaveKey* and *RegReplaceKey* functions, which are used by the Windows Backup utility. Furthermore, the system compacts the bins at hive initialization time using the Reorganization algorithm, as described later.)

The links that create the structure of a hive are called cell indexes. A cell index is the offset of a cell into the hive file minus the size of the base block. Thus, a cell index is like a pointer from one cell to another cell that the configuration manager interprets relative to the start of a hive. For example, as you saw in Table 10-6, a cell that describes a key contains a field specifying the cell index of its parent key; a cell index for a subkey specifies the cell that describes the subkeys that are subordinate to the specified subkey. A subkey-list cell contains a list of cell indexes that refer to the subkey's key cells. Therefore, if you want to locate, for example, the key cell of subkey A whose parent is key B, you must first locate the cell containing key B's subkey list using the subkey-list cell index in key B's cell. Then you locate each of key B's subkey cells by using the list of cell indexes in the subkey-list cell. For each subkey cell, you check to see whether the subkey's name, which a key cell stores, matches the one you want to locate—in this case, subkey A.

The distinction between cells, bins, and blocks can be confusing, so let's look at an example of a simple registry hive layout to help clarify the differences. The sample registry hive file in Figure 10-3 contains a base block and two bins. The first bin is empty, and the second bin contains several cells. Logically, the hive has only two keys: the root key *Root* and a subkey of *Root*, *Sub Key*. *Root* has two values, *Val 1* and *Val 2*. A subkey-list cell locates the root key's subkey, and a value-list cell locates the root key's values. The free spaces in the second bin are empty cells. Figure 10-3 doesn't show the security cells for the two keys, which would be present in a hive.

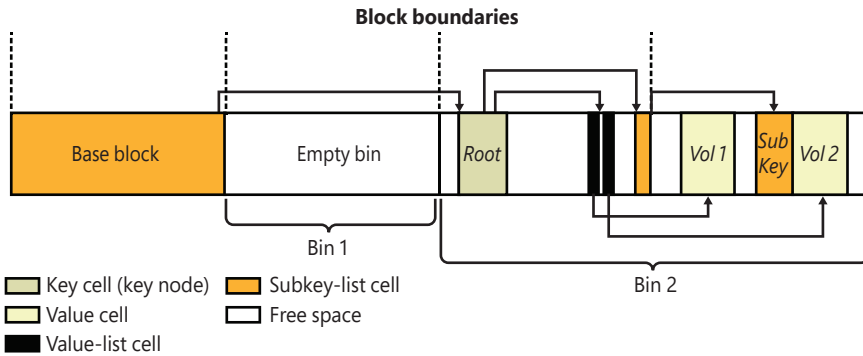

FIGURE 10-3 Internal structure of a registry hive.

To optimize searches for both values and subkeys, the configuration manager sorts subkey-list cells alphabetically. The configuration manager can then perform a binary search when it looks for a subkey within a list of subkeys. The configuration manager examines the subkey in the middle of the list, and if the name of the subkey the configuration manager is looking for alphabetically precedes the name of the middle subkey, the configuration manager knows that the subkey is in the first half of the subkey list; otherwise, the subkey is in the second half of the subkey list. This splitting process continues until the configuration manager locates the subkey or finds no match. Value-list cells aren't sorted, however, so new values are always added to the end of the list.

Cell maps

If hives never grew, the configuration manager could perform all its registry management on the in-memory version of a hive as if the hive were a file. Given a cell index, the configuration manager could calculate the location in memory of a cell simply by adding the cell index, which is a hive file offset, to the base of the in-memory hive image. Early in the system boot, this process is exactly what Winload does with the SYSTEM hive: Winload reads the entire SYSTEM hive into memory as a read-only hive and adds the cell indexes to the base of the in-memory hive image to locate cells. Unfortunately, hives grow as they take on new keys and values, which means the system must allocate new reserved views and extend the hive file to store the new bins that contain added keys and values. The reserved views that keep the registry data in memory aren't necessarily contiguous.

To deal with noncontiguous memory addresses referencing hive data in memory, the configuration manager adopts a strategy similar to what the Windows memory manager uses to map virtual memory addresses to physical memory addresses. While a cell index is only an offset in the hive file, the configuration manager employs a two-level scheme, which Figure 10-4 illustrates, when it represents the hive using the mapped views in the registry process. The scheme takes as input a cell index (that is, a hive file offset) and returns as output both the address in memory of the block the cell index resides in and the address in memory of the block the cell resides in. Remember that a bin can contain one or more blocks and that hives grow in bins, so Windows always represents a bin with a contiguous region of memory. Therefore, all blocks within a bin occur within the same 2-MB hive's mapped view.

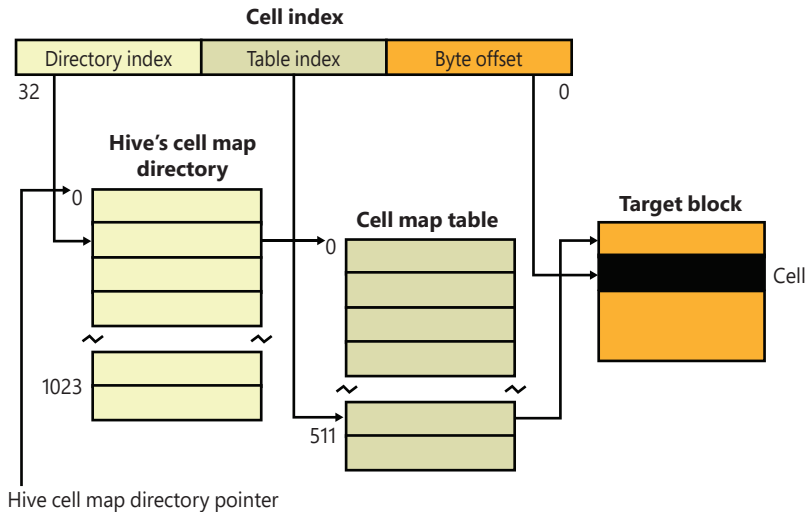

FIGURE 10-4 Structure of a cell index.

To implement the mapping, the configuration manager divides a cell index logically into fields, in the same way that the memory manager divides a virtual address into fields. Windows interprets a cell index's first field as an index into a hive's cell map directory. The cell map directory contains 1024 entries, each of which refers to a cell map table that contains 512 map entries. An entry in this cell map table is specified by the second field in the cell index. That entry locates the bin and block memory addresses of the cell.

In the final step of the translation process, the configuration manager interprets the last field of the cell index as an offset into the identified block to precisely locate a cell in memory. When a hive initializes, the configuration manager dynamically creates the mapping tables, designating a map entry for each block in the hive, and it adds and deletes tables from the cell directory as the changing size of the hive requires.

Hive reorganization

As for real file systems, registry hives suffer fragmentation problems: when cells in the bin are freed and it is not possible to coalesce them in a contiguous manner, fragmented little chunks of free space are created into various bins. If there is not enough available contiguous space for new cells, new bins are appended at the end of the hive file, while the fragmented ones will be rarely repurposed. To overcome this problem, starting from Windows 8.1, every time the configuration manager mounts a hive file, it checks whether a hive's reorganization needs to be performed. The configuration manager records the time of the last reorganization in the hive's basic block. If the hive has valid log files, is not volatile, and if the time passed after the previous reorganization is greater than seven days, the reorganization operation is started. The reorganization is an operation that has two main goals: shrink the hive file and optimize it. It starts by creating a new empty hive that is identical to the original one but does not contain any cells in it. The created clone is used to copy the root key of the original hive, with all its values (but no subkeys). A complex algorithm analyzes all the child keys: indeed, during its normal

activity, the configuration manager records whether a particular key is accessed, and, if so, stores an index representing the current runtime phase of the operating system (Boot or normal) in its key cell.

The reorganization algorithm first copies the keys accessed during the normal execution of the OS, then the ones accessed during the boot phase, and finally the keys that have not been accessed at all (since the last reorganization). This operation groups all the different keys in contiguous bins of the hive file. The copy operation, by definition, produces a nonfragmented hive file (each cell is stored sequentially in the bin, and new bin are always appended at the end of the file). Furthermore, the new hive has the characteristic to contain hot and cold classes of keys stored in big contiguous chunks. This result renders the boot and runtime phase of the operating system much quicker when reading data from the registry.

The reorganization algorithm resets the access state of all the new copied cells. In this way, the system can track the hive's keys usage by restarting from a neutral state. The new usage statistics will be consumed by the next reorganization, which will start after seven days. The configuration manager stores the results of a reorganization cycle in the HKLM\SYSTEM\CurrentControlSet\Control\Session Manager\Configuration Manager\Defrag registry key, as shown in Figure 10-5. In the sample screenshot, the last reorganization was run on April 10, 2019 and saved 10 MB of fragmented hive space.

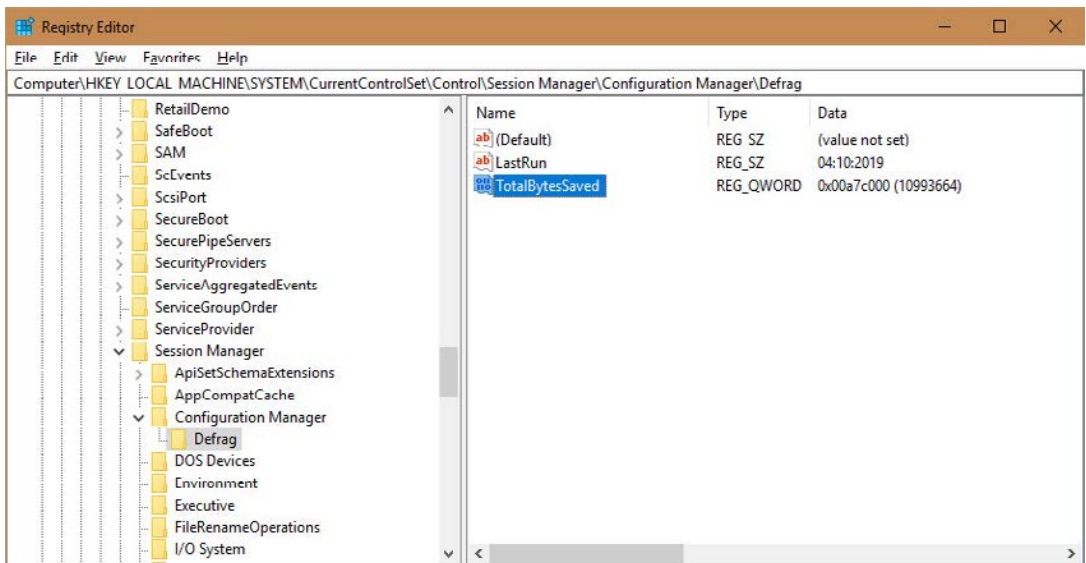

FIGURE 10-5 Registry reorganization data.

The registry namespace and operation

The configuration manager defines a key object type to integrate the registry's namespace with the kernel's general namespace. The configuration manager inserts a key object named Registry into the root of the Windows namespace, which serves as the entry point to the registry. Regedit shows key names in the form HKEY_LOCAL_MACHINE\SYSTEM\CurrentControlSet, but the Windows subsystem translates such names into their object namespace form (for example, \Registry\Machine\System\CurrentControlSet). When the Windows object manager parses this name, it encounters the key

object by the name of Registry first and hands the rest of the name to the configuration manager. The configuration manager takes over the name parsing, looking through its internal hive tree to find the desired key or value. Before we describe the flow of control for a typical registry operation, we need to discuss key objects and key control blocks. Whenever an application opens or creates a registry key, the object manager gives a handle with which to reference the key to the application. The handle corresponds to a key object that the configuration manager allocates with the help of the object manager. By using the object manager's object support, the configuration manager takes advantage of the security and reference-counting functionality that the object manager provides.

For each open registry key, the configuration manager also allocates a *key control block*. A key control block stores the name of the key, includes the cell index of the key node that the control block refers to, and contains a flag that notes whether the configuration manager needs to delete the key cell that the key control block refers to when the last handle for the key closes. Windows places all key control blocks into a hash table to enable quick searches for existing key control blocks by name. A key object points to its corresponding key control block, so if two applications open the same registry key, each receives a key object, and both key objects point to a common key control block.

When an application opens an existing registry key, the flow of control starts with the application specifying the name of the key in a registry API that invokes the object manager's name-parsing routine. The object manager, upon encountering the configuration manager's registry key object in the namespace, hands the path name to the configuration manager. The configuration manager performs a lookup on the key control block hash table. If the related key control block is found there, there's no need for any further work (no registry process attach is needed); otherwise, the lookup provides the configuration manager with the closest key control block to the searched key, and the lookup continues by attaching to the registry process and using the in-memory hive data structures to search through keys and subkeys to find the specified key. If the configuration manager finds the key cell, the configuration manager searches the key control block tree to determine whether the key is open (by the same application or another one). The search routine is optimized to always start from the closest ancestor with a key control block already opened. For example, if an application opens `\Registry\Machine\Key1\Subkey2`, and `\Registry\Machine` is already open, the parse routine uses the key control block of `\Registry\Machine` as a starting point. If the key is open, the configuration manager increments the existing key control block's reference count. If the key isn't open, the configuration manager allocates a new key control block and inserts it into the tree. Then the configuration manager allocates a key object, points the key object at the key control block, detaches from the Registry process, and returns control to the object manager, which returns a handle to the application.

When an application creates a new registry key, the configuration manager first finds the key cell for the new key's parent. The configuration manager then searches the list of free cells for the hive in which the new key will reside to determine whether cells exist that are large enough to hold the new key cell. If there aren't any free cells large enough, the configuration manager allocates a new bin and uses it for the cell, placing any space at the end of the bin on the free cell list. The new key cell fills with pertinent information—including the key's name—and the configuration manager adds the key cell to the subkey list of the parent key's subkey-list cell. Finally, the system stores the cell index of the parent cell in the new subkey's key cell.

The configuration manager uses a key control block's reference count to determine when to delete the key control block. When all the handles that refer to a key in a key control block close, the reference count becomes 0, which denotes that the key control block is no longer necessary. If an application that calls an API to delete the key sets the delete flag, the configuration manager can delete the associated key from the key's hive because it knows that no application is keeping the key open.

EXPERIMENT: Viewing key control blocks

You can use the kernel debugger to list all the key control blocks allocated on a system with the **!reg openkeys** command. Alternatively, if you want to view the key control block for a particular open key, use **!reg querykey**:

```
0: kd> !reg querykey \Registry\machine\software\microsoft
```

```
Found KCB = fffffae08c156ae60 :: \REGISTRY\MACHINE\SOFTWARE\MICROSOFT
```

```
Hive          fffffae08c03b0000
KeyNode       00000225e8c3475c
```

[SubKeyAddr]	[SubKeyName]
225e8d23e64	.NETFramework
225e8d24074	AccountsControl
225e8d240d4	Active Setup
225ec530f54	ActiveSync
225e8d241d4	Ads
225e8d2422c	Advanced INF Setup
225e8d24294	ALG
225e8d242ec	AllUserInstallAgent
225e8d24354	AMSI
225e8d243f4	Analog
225e8d2448c	AppServiceProtocols
225ec661f4c	AppV
225e8d2451c	Assistance
225e8d2458c	AuthHost
...	

You can then examine a reported key control block with the **!reg kcb** command:

```
kd> !reg kcb fffffae08c156ae60
```

```
Key          : \REGISTRY\MACHINE\SOFTWARE\MICROSOFT
RefCount     : 1f
Flags        : CompressedName, Stable
ExtFlags     :
Parent       : 0xe1997368
KeyHive      : 0xe1c8a768
KeyCell      : 0x64e598 [cell index]
TotalLevels  : 4
DelayedCloseIndex: 2048
MaxNameLen   : 0x3c
MaxValueNameLen : 0x0
MaxValueDataLen : 0x0
LastWriteTime : 0x1c42501:0x7eb6d470
KeyBodyListHead : 0xe1034d70 0xe1034d70
```

```
SubKeyCount      : 137
ValueCache.Count : 0
KCBLOCK         : 0xe1034d40
KeyLock         : 0xe1034d40
```

The *Flags* field indicates that the name is stored in compressed form, and the *SubKeyCount* field shows that the key has 137 subkeys.

Stable storage

To make sure that a nonvolatile registry hive (one with an on-disk file) is always in a recoverable state, the configuration manager uses log hives. Each nonvolatile hive has an associated log hive, which is a hidden file with the same base name as the hive and a logN extension. To ensure forward progress, the configuration manager uses a dual-logging scheme. There are potentially two log files: .log1 and .log2. If, for any reason, .log1 was written but a failure occurred while writing dirty data to the primary log file, the next time a flush happens, a switch to .log2 occurs with the cumulative dirty data. If that fails as well, the cumulative dirty data (the data in .log1 and the data that was dirtied in between) is saved in .log2. As a consequence, .log1 will be used again next time around, until a successful write operation is done to the primary log file. If no failure occurs, only .log1 is used.

For example, if you look in your %SystemRoot%\System32\Config directory (and you have the **Show Hidden Files And Folders** folder option selected and **Hide Protected Operating System Files** unselected; otherwise, you won't see any file), you'll see System.log1, Sam.log1, and other .log1 and .log2 files. When a hive initializes, the configuration manager allocates a bit array in which each bit represents a 512-byte portion, or sector, of the hive. This array is called the dirty sector array because a bit set in the array means that the system has modified the corresponding sector in the hive in memory and must write the sector back to the hive file. (A bit not set means that the corresponding sector is up to date with the in-memory hive's contents.)

When the creation of a new key or value or the modification of an existing key or value takes place, the configuration manager notes the sectors of the primary hive that change and writes them in the hive's dirty sectors array in memory. Then the configuration manager schedules a lazy flush operation, or a log sync. The hive lazy writer system thread wakes up one minute after the request to synchronize the hive's log. It generates new log entries from the in-memory hive sectors referenced by valid bits of the dirty sectors array and writes them to the hive log files on disk. At the same time, the system flushes all the registry modifications that take place between the time a hive sync is requested and the time the hive sync occurs. The lazy writer uses low priority I/Os and writes dirty sectors to the log file on disk (and not to the primary hive). When a hive sync takes place, the next hive sync occurs no sooner than one minute later.

If the lazy writer simply wrote all a hive's dirty sectors to the hive file and the system crashed in mid-operation, the hive file would be in an inconsistent (corrupted) and unrecoverable state. To prevent such an occurrence, the lazy writer first dumps the hive's dirty sector array and all the dirty sectors to the hive's log file, increasing the log file's size if necessary. A hive's basic block contains two sequence numbers. After the first flush operation (and not in the subsequent flushes), the configuration manager updates one of the sequence number, which become bigger than the second one. Thus, if the system

crashes during the write operations to the hive, at the next reboot the configuration manager notices that the two sequence numbers in the hive's base block don't match. The configuration manager can update the hive with the dirty sectors in the hive's log file to roll the hive forward. The hive is then up to date and consistent.

After writing log entries in the hive's log, the lazy flusher clears the corresponding valid bits in the dirty sector array but inserts those bits in another important vector: the unreconciled array. The latter is used by the configuration manager to understand which log entries to write in the primary hive. Thanks to the new incremental logging support (discussed later), the primary hive file is rarely written during the runtime execution of the operating system. The hive's sync protocol (not to be confused by the log sync) is the algorithm used to write all the in-memory and in-log registry's modifications to the primary hive file and to set the two sequence numbers in the hive. It is indeed an expensive multistage operation that is described later.

The Reconciler, which is another type of lazy writer system thread, wakes up once every hour, freezes up the log, and writes all the dirty log entries in the primary hive file. The reconciliation algorithm knows which parts of the in-memory hive to write to the primary file thanks to both the dirty sectors and unreconciled array. Reconciliation happens rarely, though. If a system crashes, the configuration manager has all the information needed to reconstruct a hive, thanks to the log entries that have been already written in the log files. Performing registry reconciliation only once per hour (or when the size of the log is behind a threshold, which depends on the size of the volume in which the hive reside) is a big performance improvement. The only possible time window in which some data loss could happen in the hive is between log flushes.

Note that the Reconciliation still does not update the second sequence number in the main hive file. The two sequence numbers will be updated with an equal value only in the "validation" phase (another form of hive flushing), which happens only at the hive's unload time (when an application calls the *RegUnloadKey* API), when the system shuts down, or when the hive is first loaded. This means that in most of the lifetime of the operating system, the main registry hive is in a dirty state and needs its log file to be correctly read.

The Windows Boot Loader also contains some code related to registry reliability. For example, it can parse the System.log file before the kernel is loaded and do repairs to fix consistency. Additionally, in certain cases of hive corruption (such as if a base block, bin, or cell contains data that fails consistency checks), the configuration manager can reinitialize corrupted data structures, possibly deleting subkeys in the process, and continue normal operation. If it must resort to a self-healing operation, it pops up a system error dialog box notifying the user.

Incremental logging

As mentioned in the previous section, Windows 8.1 introduced a big improvement on the performance of the hive sync algorithm thanks to incremental logging. Normally, cells in a hive file can be in four different states:

- **Clean** The cell's data is in the hive's primary file and has not been modified.
- **Dirty** The cell's data has been modified but resides only in memory.

- **Unreconciled** The cell's data has been modified and correctly written to a log file but isn't in the primary file yet.
- **Dirty and Unreconciled** After the cell has been written to the log file, it has been modified again. Only the first modification is on the log file, whereas the last one resides in memory only.

The original pre-Windows 8.1 synchronization algorithm was executing five seconds after one or more cells were modified. The algorithm can be summarized in four steps:

1. The configuration manager writes all the modified cells signaled by the dirty vector in a single entry in the log file.
2. It invalidates the hive's base block (by setting only one sequence number with an incremented value than the other one).
3. It writes all the modified data on the primary hive's file.
4. It performs the validation of the primary hive (the validation sets the two sequence numbers with an identical value in the primary hive file).

To maintain the integrity and the recoverability of the hive, the algorithm should emit a flush operation to the file system driver after each phase; otherwise, corruption could happen. Flush operations on random access data can be very expensive (especially on standard rotation disks).

Incremental logging solved the performance problem. In the legacy algorithm, one single log entry was written containing all the dirty data between multiple hive validations; the incremental model broke this assumption. The new synchronization algorithm writes a single log entry every time the lazy flusher executes, which, as discussed previously, invalidates the primary hive's base block only in the first time it executes. Subsequent flushes continue to write new log entries without touching the hive's primary file. Every hour, or if the space in the log exhausts, the Reconciler writes all the data stored in the log entries to the primary hive's file without performing the validation phase. In this way, space in the log file is reclaimed while maintaining the recoverability of the hive. If the system crashes at this stage, the log contains original entries that will be reapplied at hive loading time; otherwise, new entries are reapplied at the beginning of the log, and, in case the system crashes later, at hive load time only the new entries in the log are applied.

Figure 10-6 shows the possible crash situations and how they are managed by the incremental logging scheme. In case A, the system has written new data to the hive in memory, and the lazy flusher has written the corresponding entries in the log (but no reconciliation happened). When the system restarts, the recovery procedure applies all the log entries to the primary hive and validates the hive file again. In case B, the reconciler has already written the data stored in the log entries to the primary hive before the crash (no hive validation happened). At system reboot, the recovery procedure reapplies the existing log entries, but no modification in the primary hive file are made. Case C shows a similar situation of case B but where a new entry has been written to the log after the reconciliation. In this case, the recovery procedure writes only the last modification that is not in the primary file.

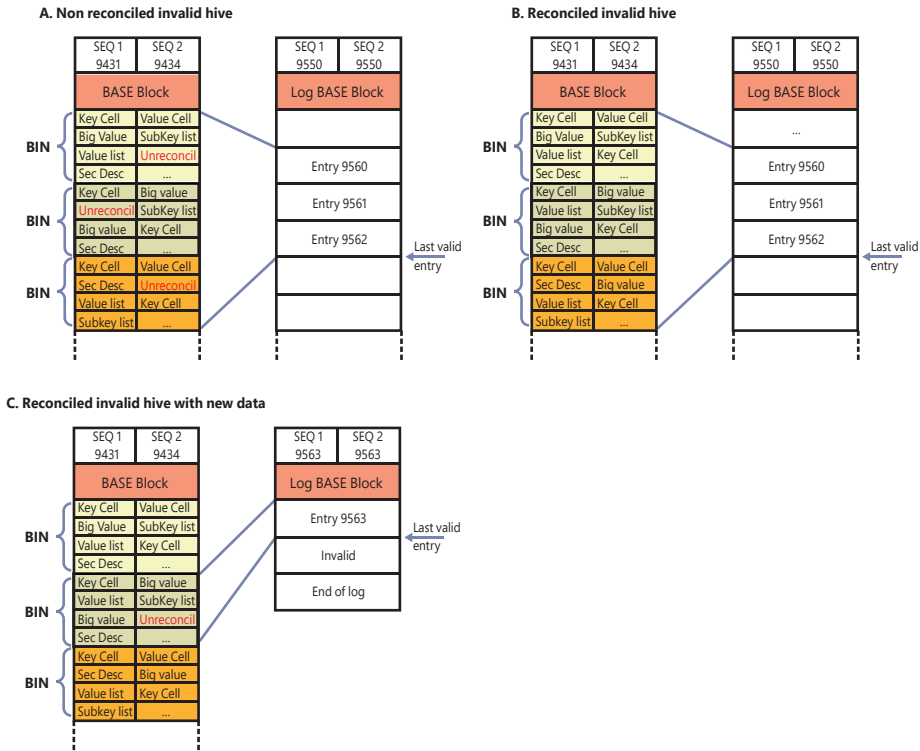

FIGURE 10-6 Consequences of possible system crashes in different times.

The hive's validation is performed only in certain (rare) cases. When a hive is unloaded, the system performs reconciliation and then validates the hive's primary file. At the end of the validation, it sets the two sequence numbers of the hive's primary file to a new identical value and emits the last file system flush request before unloading the hive from memory. When the system restarts, the hive load's code detects that the hive primary is in a clean state (thanks to the two sequence numbers having the same value) and does not start any form of the hive's recovery procedure. Thanks to the new incremental synchronization protocol, the operating system does not suffer any longer for the performance penalties brought by the old legacy logging protocol.



Note Loading a hive created by Windows 8.1 or a newer operating system in older machines is problematic in case the hive's primary file is in a non-clean state. The old OS (Windows 7, for example) has no idea how to process the new log files. For this reason, Microsoft created the *RegHiveRecovery* minifilter driver, which is distributed through the Windows Assessment and Deployment Kit (ADK). The *RegHiveRecovery* driver uses Registry callbacks, which intercept "hive load" requests from the system and determine whether the hive's primary file needs recovery and uses incremental logs. If so, it performs the recovery and fixes the hive's primary file before the system has a chance to read it.

Registry filtering

The configuration manager in the Windows kernel implements a powerful model of registry filtering, which allows for monitoring of registry activity by tools such as Process Monitor. When a driver uses the callback mechanism, it registers a callback function with the configuration manager. The configuration manager executes the driver's callback function before and after the execution of registry system services so that the driver has full visibility and control over registry accesses. Antivirus products that scan registry data for viruses or prevent unauthorized processes from modifying the registry are other users of the callback mechanism.

Registry callbacks are also associated with the concept of altitudes. Altitudes are a way for different vendors to register a "height" on the registry filtering stack so that the order in which the system calls each callback routine can be deterministic and correct. This avoids a scenario in which an anti-virus product would scan encrypted keys before an encryption product would run its own callback to decrypt them. With the Windows registry callback model, both types of tools are assigned a base altitude corresponding to the type of filtering they are doing—in this case, encryption versus scanning. Secondly, companies that create these types of tools must register with Microsoft so that within their own group, they will not collide with similar or competing products.

The filtering model also includes the ability to either completely take over the processing of the registry operation (bypassing the configuration manager and preventing it from handling the request) or redirect the operation to a different operation (such as WoW64's registry redirection). Additionally, it is also possible to modify the output parameters as well as the return value of a registry operation.

Finally, drivers can assign and tag per-key or per-operation driver-defined information for their own purposes. A driver can create and assign this context data during a create or open operation, which the configuration manager remembers and returns during each subsequent operation on the key.

Registry virtualization

Windows 10 Anniversary Update (RS1) introduced registry virtualization for Argon and Helium containers and the possibility to load differencing hives, which adhere to the new hive version 1.6. Registry virtualization is provided by both the configuration manager and the VReg driver (integrated in the Windows kernel). The two components provide the following services:

- **Namespace redirection** An application can redirect the content of a virtual key to a real one in the host. The application can also redirect a virtual key to a key belonging to a differencing hive, which is merged to a root key in the host.
- **Registry merging** Differencing hives are interpreted as a set of differences from a base hive. The base hive represents the Base Layer, which contains the Immutable registry view. Keys in a differencing hive can be an addition to the base one or a subtraction. The latter are called *thumbstone keys*.

The configuration manager, at phase 1 of the OS initialization, creates the *VRegDriver* device object (with a proper security descriptor that allows only SYSTEM and Administrator access) and the *VRegConfigurationContext* object type, which represents the Silo context used for tracking the namespace redirection and hive merging, which belongs to the container. Server silos have been covered already in Chapter 3, “Processes and jobs,” of Part 1.

Namespace redirection

Registry namespace redirection can be enabled only in a Silo container (both Server and applications silos). An application, after it has created the silo (but before starting it), sends an initialization IOCTL to the *VReg* device object, passing the handle to the silo. The *VReg* driver creates an empty configuration context and attaches it to the Silo object. It then creates a single namespace node, which remaps the *\Registry\WC* root key of the container to the host key because all containers share the same view of it. The *\Registry\WC* root key is created for mounting all the hives that are virtualized for the silo containers.

The *VReg* driver is a registry filter driver that uses the registry callbacks mechanism for properly implementing the namespace redirection. At the first time an application initializes a namespace redirection, the *VReg* driver registers its main *RegistryCallback* notification routine (through an internal API similar to *CmRegisterCallbackEx*). To properly add namespace redirection to a root key, the application sends a Create Namespace Node IOCTL to the *VReg*’s device and specifies the virtual key path (which will be seen by the container), the real host key path, and the container’s job handle. As a response, the *VReg* driver creates a new namespace node (a small data structure that contains the key’s data and some flags) and adds it to the silo’s configuration context.

After the application has finished configuring all the registry redirections for the container, it attaches its own process (or a new spawned process) to the silo object (using *AssignProcessToJobObject*—see Chapter 3 in Part 1 for more details). From this point forward, each registry I/O emitted by the containerized process will be intercepted by the *VReg* registry minifilter. Let’s illustrate how namespace redirection works through an example.

Let’s assume that the modern application framework has set multiple registry namespace redirections for a Centennial application. In particular, one of the redirection nodes redirect keys from HKCU to the host *\Registry\WC\ a20834ea-8f46-c05f-46e2-a1b71f9f2f9cuser_sid* key. At a certain point in time, the Centennial application wants to create a new key named *AppA* in the *HKCU\Software\Microsoft* parent key. When the process calls the *RegCreateKeyEx* API, the *VReg* registry callback intercepts the request and gets the job’s configuration context. It then searches in the context the closest namespace node to the key’s path specified by the caller. If it does not find anything, it returns an object not found error: Operating on nonvirtualized paths is not allowed for a container. Assuming that a namespace node describing the root HKCU key exists in the context, and the node is a parent of the *HKCU\Software\Microsoft* subkey, the *VReg* driver replaces the relative path of the original virtual key with the parent host key name and forwards the request to the configuration manager. So, in this case the configuration manager really sees a request to create *\Registry\WC\ a20834ea-8f46-c05f-46e2-a1b71f9f2f9cuser_sid\Software\Microsoft\ AppA* and succeeds. The containerized application does not really detect any difference. From the application side, the registry key is in the host HKCU.

Differencing hives

While namespace redirection is implemented in the VReg driver and is available only in containerized environments, registry merging can also work globally and is implemented mainly in the configuration manager itself. (However, the VReg driver is still used as an entry-point, allowing the mounting of differencing hives to base keys.) As stated in the previous section, differencing hives use hive version 1.6, which is very similar to version 1.5 but supports metadata for the differencing keys. Increasing the hive version also prevents the possibility of mounting the hive in systems that do not support registry virtualization.

An application can create a differencing hive and mount it globally in the system or in a silo container by sending IOCTLs to the VReg device. The *Backup and Restore* privileges are needed, though, so only administrative applications can manage differencing hives. To mount a differencing hive, the application fills a data structure with the name of the base key (called the base layer; a base layer is the root key from which all the subkeys and values contained in the differencing hive applies), the path of the differencing hive, and a mount point. It then sends the data structure to the VReg driver through the *VR_LOAD_DIFFERENCING_HIVE* control code. The mount point contains a merge of the data contained in the differencing hive and the data contained in the base layer.

The VReg driver maintains a list of all the loaded differencing hives in a hash table. This allows the VReg driver to mount a differencing hive in multiple mount points. As introduced previously, the Modern Application Model uses random GUIDs in the *\Registry\WC* root key with the goal to mount independent Centennial applications' differencing hives. After an entry in the hash table is created, the VReg driver simply forwards the request to the *CmLoadDifferencingKey* internal configuration manager's function. The latter performs the majority of the work. It calls the registry callbacks and loads the differencing hive. The creation of the hive proceeds in a similar way as for a normal hive. After the hive is created by the lower layer of the configuration manager, a key control block data structure is also created. The new key control block is linked to the base layer key control block.

When a request is directed to open or read values located in the key used as a mount point, or in a child of it, the configuration manager knows that the associated key control block represents a differencing hive. So, the parsing procedure starts from the differencing hive. If the configuration manager encounters a subkey in the differencing hive, it stops the parsing procedure and yields the keys and data stored in the differencing hive. Otherwise, in case no data is found in the differencing hive, the configuration manager restarts the parsing procedure from the base hive. Another case verifies whether a thumbstone key is found in the differencing hive: the configuration manager hides the searched key and returns no data (or an error). Thumb stones are indeed used to mark a key as deleted in the base hive.

The system supports three kinds of differencing hives:

- **Mutable hives** can be written and updated. All the write requests directed to the mount point (or to its children keys) are stored in the differencing hive.
- **Immutable hives** can't be modified. This means that all the modifications requested on a key that is located in the differencing hive will fail.

- **Write-through hives** represent differencing hives that are immutable, but write requests directed to the mount point (or its children keys) are redirected to the base layer (which is not immutable anymore).

The NT kernel and applications can also mount a differencing hive and then apply namespace redirection on the top of its mount point, which allows the implementation of complex virtualized configurations like the one employed for Centennial applications (shown in Figure 10-7). The Modern Application Model and the architecture of Centennial applications are covered in Chapter 8.

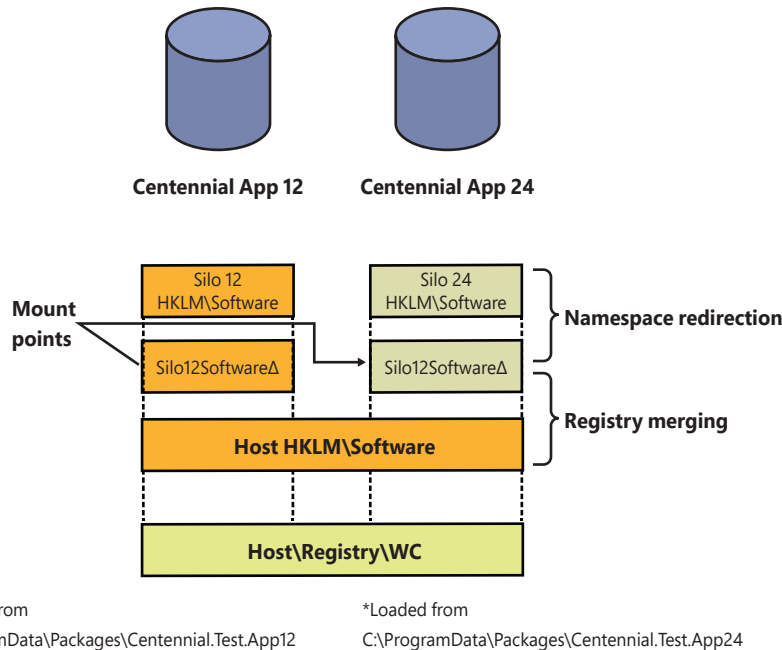

FIGURE 10-7 Registry virtualization of the software hive in the Modern Application Model for Centennial applications.

Registry optimizations

The configuration manager makes a few noteworthy performance optimizations. First, virtually every registry key has a security descriptor that protects access to the key. However, storing a unique security descriptor copy for every key in a hive would be highly inefficient because the same security settings often apply to entire subtrees of the registry. When the system applies security to a key, the configuration manager checks a pool of the unique security descriptors used within the same hive as the key to which new security is being applied, and it shares any existing descriptor for the key, ensuring that there is at most one copy of every unique security descriptor in a hive.

The configuration manager also optimizes the way it stores key and value names in a hive. Although the registry is fully Unicode-capable and specifies all names using the Unicode convention, if a name contains only ASCII characters, the configuration manager stores the name in ASCII form in the hive.

When the configuration manager reads the name (such as when performing name lookups), it converts the name into Unicode form in memory. Storing the name in ASCII form can significantly reduce the size of a hive.

To minimize memory usage, key control blocks don't store full key registry path names. Instead, they reference only a key's name. For example, a key control block that refers to `\Registry\System\Control` would refer to the name `Control` rather than to the full path. A further memory optimization is that the configuration manager uses key name control blocks to store key names, and all key control blocks for keys with the same name share the same key name control block. To optimize performance, the configuration manager stores the key control block names in a hash table for quick lookups.

To provide fast access to key control blocks, the configuration manager stores frequently accessed key control blocks in the cache table, which is configured as a hash table. When the configuration manager needs to look up a key control block, it first checks the cache table. Finally, the configuration manager has another cache, the delayed close table, that stores key control blocks that applications close so that an application can quickly reopen a key it has recently closed. To optimize lookups, these cache tables are stored for each hive. The configuration manager removes the oldest key control blocks from the delayed close table because it adds the most recently closed blocks to the table.

Windows services

Almost every operating system has a mechanism to start processes at system startup time not tied to an interactive user. In Windows, such processes are called services or Windows services. Services are similar to UNIX daemon processes and often implement the server side of client/server applications. An example of a Windows service might be a web server because it must be running regardless of whether anyone is logged on to the computer, and it must start running when the system starts so that an administrator doesn't have to remember, or even be present, to start it.

Windows services consist of three components: a service application, a service control program (SCP), and the Service Control Manager (SCM). First, we describe service applications, service accounts, user and packaged services, and all the operations of the SCM. Then we explain how autostart services are started during the system boot. We also cover the steps the SCM takes when a service fails during its startup and the way the SCM shuts down services. We end with the description of the Shared service process and how protected services are managed by the system.

Service applications

Service applications, such as web servers, consist of at least one executable that runs as a Windows service. A user who wants to start, stop, or configure a service uses a SCP. Although Windows supplies built-in SCPs (the most common are the command-line tool `sc.exe` and the user interface provided by the `services.msc` MMC snap-in) that provide generic start, stop, pause, and continue functionality, some service applications include their own SCP that allows administrators to specify configuration settings particular to the service they manage.

Service applications are simply Windows executables (GUI or console) with additional code to receive commands from the SCM as well as to communicate the application's status back to the SCM. Because most services don't have a user interface, they are built as console programs.

When you install an application that includes a service, the application's setup program (which usually acts as an SCP too) must register the service with the system. To register the service, the setup program calls the Windows *CreateService* function, a services-related function exported in Advapi32.dll (%SystemRoot%\System32\Advapi32.dll). Advapi32, the Advanced API DLL, implements only a small portion of the client-side SCM APIs. All the most important SCM client APIs are implemented in another DLL, Sechost.dll, which is the host library for SCM and LSA client APIs. All the SCM APIs not implemented in Advapi32.dll are simply forwarded to Sechost.dll. Most of the SCM client APIs communicate with the Service Control Manager through RPC. SCM is implemented in the Services.exe binary. More details are described later in the "Service Control Manager" section.

When a setup program registers a service by calling *CreateService*, an RPC call is made to the SCM instance running on the target machine. The SCM then creates a registry key for the service under HKLM\SYSTEM\CurrentControlSet\Services. The *Services* key is the nonvolatile representation of the SCM's database. The individual keys for each service define the path of the executable image that contains the service as well as parameters and configuration options.

After creating a service, an installation or management application can start the service via the *StartService* function. Because some service-based applications also must initialize during the boot process to function, it's not unusual for a setup program to register a service as an autostart service, ask the user to reboot the system to complete an installation, and let the SCM start the service as the system boots.

When a program calls *CreateService*, it must specify a number of parameters describing the service's characteristics. The characteristics include the service's type (whether it's a service that runs in its own process rather than a service that shares a process with other services), the location of the service's executable image file, an optional display name, an optional account name and password used to start the service in a particular account's security context, a start type that indicates whether the service starts automatically when the system boots or manually under the direction of an SCP, an error code that indicates how the system should react if the service detects an error when starting, and, if the service starts automatically, optional information that specifies when the service starts relative to other services. While delay-loaded services are supported since Windows Vista, Windows 7 introduced support for Triggered services, which are started or stopped when one or more specific events are verified. An SCP can specify trigger event information through the *ChangeServiceConfig2* API.

A service application runs in a service process. A service process can host one or more service applications. When the SCM starts a service process, the process must immediately invoke the *StartServiceCtrlDispatcher* function (before a well-defined timeout expires—see the "Service logon" section for more details). *StartServiceCtrlDispatcher* accepts a list of entry points into services, with one entry point for each service in the process. Each entry point is identified by the name of the service the entry point corresponds to. After making a local RPC (ALPC) communications connection to the SCM (which acts as a pipe), *StartServiceCtrlDispatcher* waits in a loop for commands to come through the pipe from the SCM. Note that the handle of the connection is saved by the SCM in an internal

list, which is used for sending and receiving service commands to the right process. The SCM sends a service-start command each time it starts a service the process owns. For each start command it receives, the *StartServiceCtrlDispatcher* function creates a thread, called a service thread, to invoke the starting service's entry point (*Service Main*) and implement the command loop for the service. *StartServiceCtrlDispatcher* waits indefinitely for commands from the SCM and returns control to the process's main function only when all the process's services have stopped, allowing the service process to clean up resources before exiting.

A service entry point's (*ServiceMain*) first action is to call the *RegisterServiceCtrlHandler* function. This function receives and stores a pointer to a function, called the control handler, which the service implements to handle various commands it receives from the SCM. *RegisterServiceCtrlHandler* doesn't communicate with the SCM, but it stores the function in local process memory for the *StartServiceCtrlDispatcher* function. The service entry point continues initializing the service, which can include allocating memory, creating communications end points, and reading private configuration data from the registry. As explained earlier, a convention most services follow is to store their parameters under a subkey of their service registry key, named *Parameters*.

While the entry point is initializing the service, it must periodically send status messages, using the *SetServiceStatus* function, to the SCM indicating how the service's startup is progressing. After the entry point finishes initialization (the service indicates this to the SCM through the *SERVICE_RUNNING* status), a service thread usually sits in a loop waiting for requests from client applications. For example, a web server would initialize a TCP listen socket and wait for inbound HTTP connection requests.

A service process's main thread, which executes in the *StartServiceCtrlDispatcher* function, receives SCM commands directed at services in the process and invokes the target service's control handler function (stored by *RegisterServiceCtrlHandler*). SCM commands include stop, pause, resume, interrogate, and shutdown or application-defined commands. Figure 10-8 shows the internal organization of a service process—the main thread and the service thread that make up a process hosting one service.

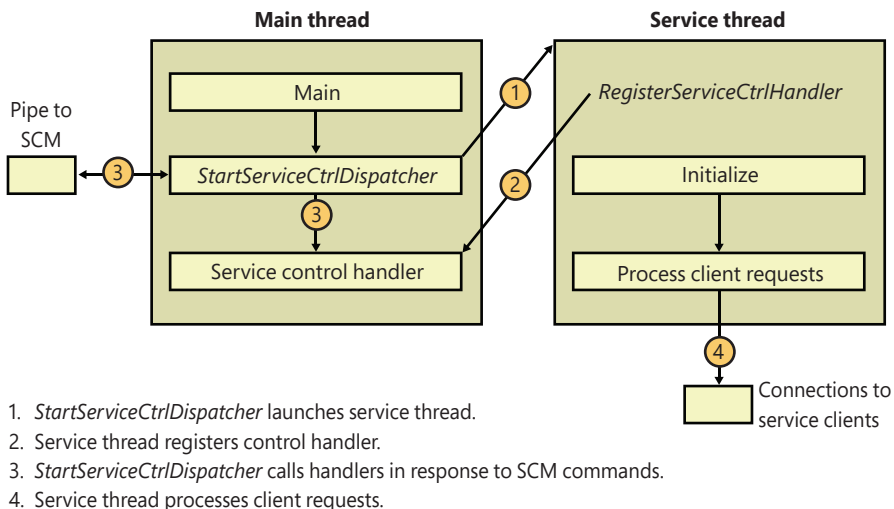

FIGURE 10-8 Inside a service process.

Service characteristics

The SCM stores each characteristic as a value in the service's registry key. Figure 10-9 shows an example of a service registry key.

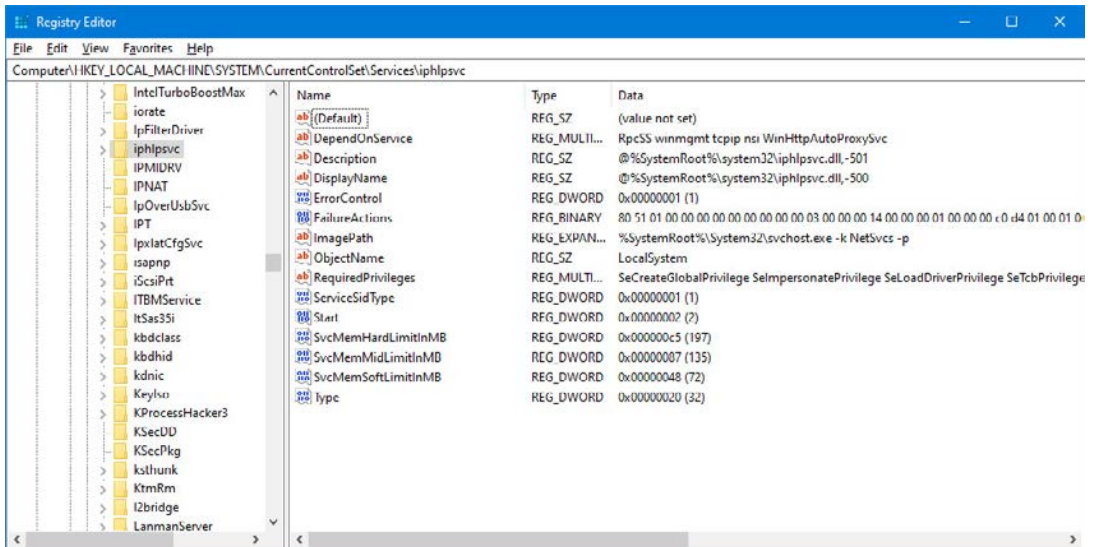

FIGURE 10-9 Example of a service registry key.

Table 10-7 lists all the service characteristics, many of which also apply to device drivers. (Not every characteristic applies to every type of service or device driver.)



Note The SCM does not access a service's *Parameters* subkey until the service is deleted, at which time the SCM deletes the service's entire key, including subkeys like *Parameters*.

TABLE 10-7 Service and Driver Registry Parameters

Value Setting	Value Name	Value Setting Description
Start	SERVICE_BOOT_START (0x0)	Winload preloads the driver so that it is in memory during the boot. These drivers are initialized just prior to <i>SERVICE_SYSTEM_START</i> drivers.
	SERVICE_SYSTEM_START (0x1)	The driver loads and initializes during kernel initialization after <i>SERVICE_BOOT_START</i> drivers have initialized.
	SERVICE_AUTO_START (0x2)	The SCM starts the driver or service after the SCM process, <i>Services.exe</i> , starts.
	SERVICE_DEMAND_START (0x3)	The SCM starts the driver or service on demand (when a client calls <i>StartService</i> on it, it is trigger started, or when another starting service is dependent on it.)
	SERVICE_DISABLED (0x4)	The driver or service cannot be loaded or initialized.

Value Setting	Value Name	Value Setting Description
ErrorControl	SERVICE_ERROR_IGNORE (0x0)	Any error the driver or service returns is ignored, and no warning is logged or displayed.
	SERVICE_ERROR_NORMAL (0x1)	If the driver or service reports an error, an event log message is written.
	SERVICE_ERROR_SEVERE (0x2)	If the driver or service returns an error and last known good isn't being used, reboot into last known good; otherwise, log an event message.
	SERVICE_ERROR_CRITICAL (0x3)	If the driver or service returns an error and last known good isn't being used, reboot into last known good; otherwise, log an event message.
Type	SERVICE_KERNEL_DRIVER (0x1)	Device driver.
	SERVICE_FILE_SYSTEM_DRIVER (0x2)	Kernel-mode file system driver.
	SERVICE_ADAPTER (0x4)	Obsolete.
	SERVICE_RECOGNIZER_DRIVER (0x8)	File system recognizer driver.
	SERVICE_WIN32_OWN_PROCESS (0x10)	The service runs in a process that hosts only one service.
	SERVICE_WIN32_SHARE_PROCESS (0x20)	The service runs in a process that hosts multiple services.
	SERVICE_USER_OWN_PROCESS (0x50)	The service runs with the security token of the logged-in user in its own process.
	SERVICE_USER_SHARE_PROCESS (0x60)	The service runs with the security token of the logged-in user in a process that hosts multiple services.
	SERVICE_INTERACTIVE_PROCESS (0x100)	The service is allowed to display windows on the console and receive user input, but only on the console session (0) to prevent interacting with user/console applications on other sessions. This option is deprecated.
Group	Group name	The driver or service initializes when its group is initialized.
Tag	Tag number	The specified location in a group initialization order. This parameter doesn't apply to services.
ImagePath	Path to the service or driver executable file	If ImagePath isn't specified, the I/O manager looks for drivers in %SystemRoot%\System32\Drivers. Required for Windows services.
DependOnGroup	Group name	The driver or service won't load unless a driver or service from the specified group loads.
DependOnService	Service name	The service won't load until after the specified service loads. This parameter doesn't apply to device drivers or services with a start type different than <i>SERVICE_AUTO_START</i> or <i>SERVICE_DEMAND_START</i> .
ObjectName	Usually LocalSystem, but it can be an account name, such as .\Administrator	Specifies the account in which the service will run. If ObjectName isn't specified, LocalSystem is the account used. This parameter doesn't apply to device drivers.
DisplayName	Name of the service	The service application shows services by this name. If no name is specified, the name of the service's registry key becomes its name.

Value Setting	Value Name	Value Setting Description
DeleteFlag	0 or 1 (TRUE or FALSE)	Temporary flag set by the SCM when a service is marked to be deleted.
Description	Description of service	Up to 32,767-byte description of the service.
FailureActions	Description of actions the SCM should take when the service process exits unexpectedly	Failure actions include restarting the service process, rebooting the system, and running a specified program. This value doesn't apply to drivers.
FailureCommand	Program command line	The SCM reads this value only if FailureActions specifies that a program should execute upon service failure. This value doesn't apply to drivers.
DelayedAutoStart	0 or 1 (TRUE or FALSE)	Tells the SCM to start this service after a certain delay has passed since the SCM was started. This reduces the number of services starting simultaneously during startup.
PreshutdownTimeout	Timeout in milliseconds	This value allows services to override the default pre-shutdown notification timeout of 180 seconds. After this timeout, the SCM performs shutdown actions on the service if it has not yet responded.
ServiceSidType	<i>SERVICE_SID_TYPE_NONE</i> (0x0)	Backward-compatibility setting.
	<i>SERVICE_SID_TYPE_UNRESTRICTED</i> (0x1)	The SCM adds the service SID as a group owner to the service process's token when it is created.
	<i>SERVICE_SID_TYPE_RESTRICTED</i> (0x3)	The SCM runs the service with a write-restricted token, adding the service SID to the restricted SID list of the service process, along with the world, logon, and write-restricted SIDs.
Alias	String	Name of the service's alias.
RequiredPrivileges	List of privileges	This value contains the list of privileges that the service requires to function. The SCM computes their union when creating the token for the shared process related to this service, if any.
Security	Security descriptor	This value contains the optional security descriptor that defines who has what access to the service object created internally by the SCM. If this value is omitted, the SCM applies a default security descriptor.
LaunchProtected	<i>SERVICE_LAUNCH_PROTECTED_NONE</i> (0x0)	The SCM launches the service unprotected (default value).
	<i>SERVICE_LAUNCH_PROTECTED_WINDOWS</i> (0x1)	The SCM launches the service in a Windows protected process.
	<i>SERVICE_LAUNCH_PROTECTED_WINDOWS_LIGHT</i> (0x2)	The SCM launches the service in a Windows protected process light.
	<i>SERVICE_LAUNCH_PROTECTED_ANTIMALWARE_LIGHT</i> (0x3)	The SCM launches the service in an Antimalware protected process light.
	<i>SERVICE_LAUNCH_PROTECTED_APP_LIGHT</i> (0x4)	The SCM launches the service in an App protected process light (internal only).

Value Setting	Value Name	Value Setting Description
UserServiceFlags	<i>USER_SERVICE_FLAG_DSMA_ALLOW</i> (0x1)	Allow the default user to start the user service.
	<i>USER_SERVICE_FLAG_NONDSMA_ALLOW</i> (0x2)	Do not allow the default user to start the service.
SvcHostSplitDisable	0 or 1 (TRUE or FALSE)	When set to, 1 prohibits the SCM to enable Svchost splitting. This value applies only to shared services.
PackageFullName	String	Package full name of a packaged service.
AppUserModelId	String	Application user model ID (AUMID) of a packaged service.
PackageOrigin	<i>PACKAGE_ORIGIN_UNSIGNED</i> (0x1) <i>PACKAGE_ORIGIN_INBOX</i> (0x2) <i>PACKAGE_ORIGIN_STORE</i> (0x3) <i>PACKAGE_ORIGIN_DEVELOPER_UNSIGNED</i> (0x4) <i>PACKAGE_ORIGIN_DEVELOPER_SIGNED</i> (0x5)	These values identify the origin of the AppX package (the entity that has created it).

Notice that *Type* values include three that apply to device drivers: device driver, file system driver, and file system recognizer. These are used by Windows device drivers, which also store their parameters as registry data in the *Services* registry key. The SCM is responsible for starting non-PNP drivers with a *Start* value of *SERVICE_AUTO_START* or *SERVICE_DEMAND_START*, so it's natural for the SCM database to include drivers. Services use the other types, *SERVICE_WIN32_OWN_PROCESS* and *SERVICE_WIN32_SHARE_PROCESS*, which are mutually exclusive.

An executable that hosts just one service uses the *SERVICE_WIN32_OWN_PROCESS* type. In a similar way, an executable that hosts multiple services specifies the *SERVICE_WIN32_SHARE_PROCESS*. Hosting multiple services in a single process saves system resources that would otherwise be consumed as overhead when launching multiple service processes. A potential disadvantage is that if one of the services of a collection running in the same process causes an error that terminates the process, all the services of that process terminate. Also, another limitation is that all the services must run under the same account (however, if a service takes advantage of service security hardening mechanisms, it can limit some of its exposure to malicious attacks). The *SERVICE_USER_SERVICE* flag is added to denote a user service, which is a type of service that runs with the identity of the currently logged-on user.

Trigger information is normally stored by the SCM under another subkey named *TriggerInfo*. Each trigger event is stored in a child key named as the event index, starting from 0 (for example, the third trigger event is stored in the "*TriggerInfo\2*" subkey). Table 10-8 lists all the possible registry values that compose the trigger information.

TABLE 10-8 Triggered services registry parameters

Value Setting	Value Name	Value Setting Description
Action	<i>SERVICE_TRIGGER_ACTION_SERVICE_START</i> (0x1)	Start the service when the trigger event occurs.
	<i>SERVICE_TRIGGER_ACTION_SERVICE_STOP</i> (0x2)	Stop the service when the trigger event occurs.
Type	<i>SERVICE_TRIGGER_TYPE_DEVICE_INTERFACE_ARRIVAL</i> (0x1)	Specifies an event triggered when a device of the specified device interface class arrives or is present when the system starts.
	<i>SERVICE_TRIGGER_TYPE_IP_ADDRESS_AVAILABILITY</i> (0x2)	Specifies an event triggered when an IP address becomes available or unavailable on the network stack.
	<i>SERVICE_TRIGGER_TYPE_DOMAIN_JOIN</i> (0x3)	Specifies an event triggered when the computer joins or leaves a domain.
	<i>SERVICE_TRIGGER_TYPE_FIREWALL_PORT_EVENT</i> (0x4)	Specifies an event triggered when a firewall port is opened or closed.
	<i>SERVICE_TRIGGER_TYPE_GROUP_POLICY</i> (0x5)	Specifies an event triggered when a machine or user policy change occurs.
	<i>SERVICE_TRIGGER_TYPE_NETWORK_ENDPOINT</i> (0x6)	Specifies an event triggered when a packet or request arrives on a particular network protocol.
	<i>SERVICE_TRIGGER_TYPE_CUSTOM</i> (0x14)	Specifies a custom event generated by an ETW provider.
Guid	Trigger subtype GUID	A GUID that identifies the trigger event subtype. The GUID depends on the Trigger type.
Data[Index]	Trigger-specific data	Trigger-specific data for the service trigger event. This value depends on the trigger event type.
DataType[Index]	<i>SERVICE_TRIGGER_DATA_TYPE_BINARY</i> (0x1)	The trigger-specific data is in binary format.
	<i>SERVICE_TRIGGER_DATA_TYPE_STRING</i> (0x2)	The trigger-specific data is in string format.
	<i>SERVICE_TRIGGER_DATA_TYPE_LEVEL</i> (0x3)	The trigger-specific data is a byte value.
	<i>SERVICE_TRIGGER_DATA_TYPE_KEYWORD_ANY</i> (0x4)	The trigger-specific data is a 64-bit (8 bytes) unsigned integer value.
	<i>SERVICE_TRIGGER_DATA_TYPE_KEYWORD_ALL</i> (0x5)	The trigger-specific data is a 64-bit (8 bytes) unsigned integer value.

Service accounts

The security context of a service is an important consideration for service developers as well as for system administrators because it dictates which resource the process can access. Most built-in services run in the security context of an appropriate Service account (which has limited access rights, as described in the following subsections). When a service installation program or the system administrator creates a service, it usually specifies the security context of the local system account (displayed sometimes as SYSTEM and other times as LocalSystem), which is very powerful. Two other built-in accounts are the network service and local service accounts. These accounts have fewer capabilities than the local system account from a security standpoint. The following subsections describe the special characteristics of all the service accounts.

The local system account

The local system account is the same account in which core Windows user-mode operating system components run, including the Session Manager (%SystemRoot%\System32\Smss.exe), the Windows subsystem process (Csrss.exe), the Local Security Authority process (%SystemRoot%\System32\lsass.exe), and the Logon process (%SystemRoot%\System32\Winlogon.exe). For more information on these processes, see Chapter 7 in Part 1.

From a security perspective, the local system account is extremely powerful—more powerful than any local or domain account when it comes to security ability on a local system. This account has the following characteristics:

- It is a member of the local Administrators group. Table 10-9 shows the groups to which the local system account belongs. (See Chapter 7 in Part 1 for information on how group membership is used in object access checks.)
- It has the right to enable all privileges (even privileges not normally granted to the local administrator account, such as creating security tokens). See Table 10-10 for the list of privileges assigned to the local system account. (Chapter 7 in Part 1 describes the use of each privilege.)
- Most files and registry keys grant full access to the local system account. Even if they don't grant full access, a process running under the local system account can exercise the take-ownership privilege to gain access.
- Processes running under the local system account run with the default user profile (HKU\DEFAULT). Therefore, they can't directly access configuration information stored in the user profiles of other accounts (unless they explicitly use the *LoadUserProfile* API).
- When a system is a member of a Windows domain, the local system account includes the machine security identifier (SID) for the computer on which a service process is running. Therefore, a service running in the local system account will be automatically authenticated on other machines in the same forest by using its computer account. (A *forest* is a grouping of domains.)
- Unless the machine account is specifically granted access to resources (such as network shares, named pipes, and so on), a process can access network resources that allow null sessions—that is, connections that require no credentials. You can specify the shares and pipes on a particular computer that permit null sessions in the *NullSessionPipes* and *NullSessionShares* registry values under HKLM\SYSTEM\CurrentControlSet\Services\LanmanServer\Parameters.

TABLE 10-9 Service account group membership (and integrity level)

Local System	Network Service	Local Service	Service Account
Administrators Everyone Authenticated users	Everyone Users Authenticated users Local Network service Console logon	Everyone Users Authenticated users Local Local service Console logon UWP capabilities groups	Everyone Users Authenticated users Local Local service All services Write restricted Console logon
System integrity level	System integrity level	System integrity level	High integrity Level

TABLE 10-10 Service account privileges

Local System	Local Service / Network Service	Service Account
SeAssignPrimaryTokenPrivilege	SeAssignPrimaryTokenPrivilege	SeChangeNotifyPrivilege
SeAuditPrivilege	SeAuditPrivilege	SeCreateGlobalPrivilege
SeBackupPrivilege	SeChangeNotifyPrivilege	SeImpersonatePrivilege
SeChangeNotifyPrivilege	SeCreateGlobalPrivilege	SeIncreaseWorkingSetPrivilege
SeCreateGlobalPrivilege	SeImpersonatePrivilege	SeShutdownPrivilege
SeCreatePagefilePrivilege	SeIncreaseQuotaPrivilege	SeTimeZonePrivilege
SeCreatePermanentPrivilege	SeIncreaseWorkingSetPrivilege	SeUndockPrivilege
SeCreateSymbolicLinkPrivilege	SeShutdownPrivilege	
SeCreateTokenPrivilege	SeSystemtimePrivilege	
SeDebugPrivilege	SeTimeZonePrivilege	
SeDelegateSessionUserImpersonatePrivilege	SeUndockPrivilege (client only)	
SeImpersonatePrivilege		
SeIncreaseBasePriorityPrivilege		
SeIncreaseQuotaPrivilege		
SeIncreaseWorkingSetPrivilege		
SeLoadDriverPrivilege		
SeLockMemoryPrivilege		
SeManageVolumePrivilege		
SeProfileSingleProcessPrivilege		
SeRestorePrivilege		
SeSecurityPrivilege		
SeShutdownPrivilege		
SeSystemEnvironmentPrivilege		
SeSystemProfilePrivilege		
SeSystemtimePrivilege		
SeTakeOwnershipPrivilege		
SeTcbPrivilege		
SeTimeZonePrivilege		
SeTrustedCredManAccessPrivilege		
SeRelabelPrivilege		
SeUndockPrivilege (client only)		

The network service account

The network service account is intended for use by services that want to authenticate to other machines on the network using the computer account, as does the local system account, but do not have the need for membership in the Administrators group or the use of many of the privileges assigned to the local system account. Because the network service account does not belong to the Administrators group, services running in the network service account by default have access to far fewer registry keys, file system folders, and files than the services running in the local system account. Further, the assignment of few privileges limits the scope of a compromised network service process. For example, a process running in the network service account cannot load a device driver or open arbitrary processes.

Another difference between the network service and local system accounts is that processes running in the network service account use the network service account's profile. The registry component of the network service profile loads under HKU\S-1-5-20, and the files and directories that make up the component reside in %SystemRoot%\ServiceProfiles\NetworkService.

A service that runs in the network service account is the DNS client, which is responsible for resolving DNS names and for locating domain controllers.

The local service account

The local service account is virtually identical to the network service account with the important difference that it can access only network resources that allow anonymous access. Table 10-10 shows that the network service account has the same privileges as the local service account, and Table 10-9 shows that it belongs to the same groups with the exception that it belongs to the local service group instead of the network service group. The profile used by processes running in the local service loads into HKU\S-1-5-19 and is stored in %SystemRoot%\ServiceProfiles\LocalService.

Examples of services that run in the local service account include the Remote Registry Service, which allows remote access to the local system's registry, and the LmHosts service, which performs NetBIOS name resolution.

Running services in alternate accounts

Because of the restrictions just outlined, some services need to run with the security credentials of a user account. You can configure a service to run in an alternate account when the service is created or by specifying an account and password that the service should run under with the Windows Services MMC snap-in. In the Services snap-in, right-click a service and select **Properties**, click the **Log On** tab, and select the **This Account** option, as shown in Figure 10-10.

Note that when required to start, a service running with an alternate account is always launched using the alternate account credentials, even though the account is not currently logged on. This means that the user profile is loaded even though the user is not logged on. User Services, which are described later in this chapter (in the "User services" section), have also been designed to overcome this problem. They are loaded only when the user logs on.

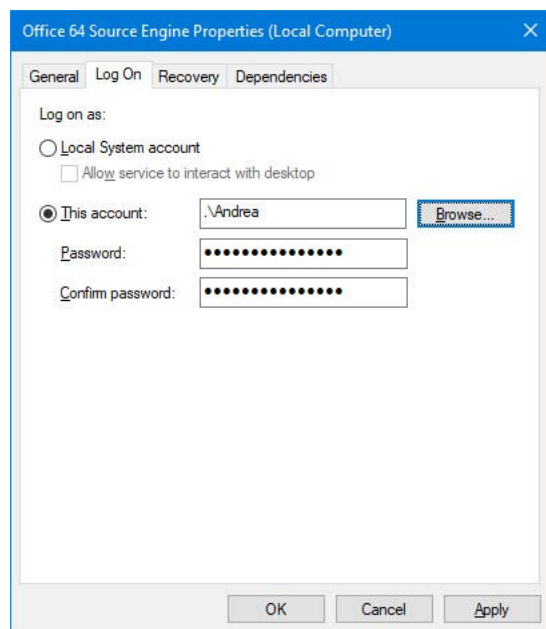

FIGURE 10-10 Service account settings.

Running with least privilege

A service's process typically is subject to an all-or-nothing model, meaning that all privileges available to the account the service process is running under are available to a service running in the process that might require only a subset of those privileges. To better conform to the principle of least privilege, in which Windows assigns services only the privileges they require, developers can specify the privileges their service requires, and the SCM creates a security token that contains only those privileges.

Service developers use the *ChangeServiceConfig2* API (specifying the *SERVICE_CONFIG_REQUIRED_PRIVILEGES_INFO* information level) to indicate the list of privileges they desire. The API saves that information in the registry into the *RequiredPrivileges* value of the root service key (refer to Table 10-7). When the service starts, the SCM reads the key and adds those privileges to the token of the process in which the service is running.

If there is a *RequiredPrivileges* value and the service is a stand-alone service (running as a dedicated process), the SCM creates a token containing only the privileges that the service needs. For services running as part of a shared service process (as are a subset of services that are part of Windows) and specifying required privileges, the SCM computes the union of those privileges and combines them for the service-hosting process's token. In other words, only the privileges not specified by any of the services that are hosted in the same service process will be removed. In the case in which the registry value does not exist, the SCM has no choice but to assume that the service is either incompatible with least privileges or requires all privileges to function. In this case, the full token is created, containing all privileges, and no additional security is offered by this model. To strip almost all privileges, services can specify only the *Change Notify* privilege.



Note The privileges a service specifies must be a subset of those that are available to the service account in which it runs.

EXPERIMENT: Viewing privileges required by services

You can view the privileges a service requires with the Service Control utility, *sc.exe*, and the **qprivs** option. Additionally, Process Explorer can show you information about the security token of any service process on the system, so you can compare the information returned by *sc.exe* with the privileges part of the token. The following steps show you how to do this for some of the best locked-down services on the system.

1. Use *sc.exe* to look at the required privileges specified by *CryptSvc* by typing the following into a command prompt:

```
sc qprivs cryptsvc
```

You should see three privileges being requested: the *SeChangeNotifyPrivilege*, *SeCreateGlobalPrivilege*, and the *SeImpersonatePrivilege*.

2. Run Process Explorer as administrator and look at the process list.
 You should see multiple Svchost.exe processes that are hosting the services on your machine (in case Svchost splitting is enabled, the number of Svchost instances are even more). Process Explorer highlights these in pink.
3. CryptSvc is a service that runs in a shared hosting process. In Windows 10, locating the correct process instance is easily achievable through Task Manager. You do not need to know the name of the Service DLL, which is listed in the HKLM\SYSTEM\CurrentControlSet\Services\CryptSvc\Parameters registry key.
4. Open Task Manager and look at the Services tab. You should easily find the PID of the CryptSvc hosting process.
5. Return to Process Explorer and double-click the Svchost.exe process that has the same PID found by Task Manager to open the **Properties** dialog box.
6. Double check that the **Services** tab includes the CryptSvc service. If service splitting is enabled, it should contain only one service; otherwise, it will contain multiple services. Then click the **Security** tab. You should see security information similar to the following figure:

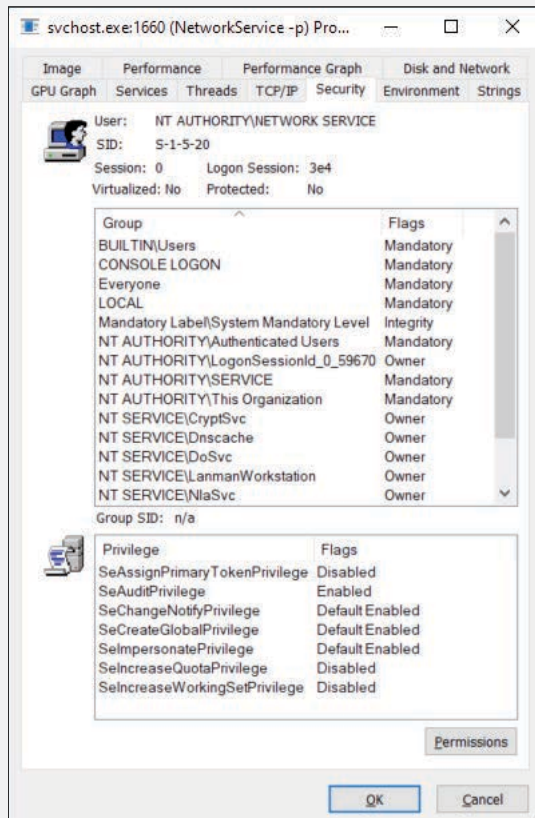

Note that although the service is running as part of the local service account, the list of privileges Windows assigned to it is much shorter than the list available to the local service account shown in Table 10-10.

For a service-hosting process, the privileges part of the token is the union of the privileges requested by all the services running inside it, so this must mean that services such as DnsCache and LanmanWorkstation have not requested privileges other than the ones shown by Process Explorer. You can verify this by running the Sc.exe tool on those other services as well (only if Svchost Service Splitting is disabled).

Service isolation

Although restricting the privileges that a service has access to helps lessen the ability of a compromised service process to compromise other processes, it does nothing to isolate the service from resources that the account in which it is running has access under normal conditions. As mentioned earlier, the local system account has complete access to critical system files, registry keys, and other securable objects on the system because the access control lists (ACLs) grant permissions to that account.

At times, access to some of these resources is critical to a service's operation, whereas other objects should be secured from the service. Previously, to avoid running in the local system account to obtain access to required resources, a service would be run under a standard user account, and ACLs would be added on the system objects, which greatly increased the risk of malicious code attacking the system. Another solution was to create dedicated service accounts and set specific ACLs for each account (associated to a service), but this approach easily became an administrative hassle.

Windows now combines these two approaches into a much more manageable solution: it allows services to run in a nonprivileged account but still have access to specific privileged resources without lowering the security of those objects. Indeed, the ACLs on an object can now set permissions directly for a service, but not by requiring a dedicated account. Instead, Windows generates a service SID to represent a service, and this SID can be used to set permissions on resources such as registry keys and files.

The Service Control Manager uses service SIDs in different ways. If the service is configured to be launched using a virtual service account (in the NT SERVICE\ domain), a service SID is generated and assigned as the main user of the new service's token. The token will also be part of the NT SERVICE\ALL SERVICES group. This group is used by the system to allow a securable object to be accessed by any service. In the case of shared services, the SCM creates the service-hosting processes (a process that contains more than one service) with a token that contains the service SIDs of all services that are part of the service group associated with the process, including services that are not yet started (there is no way to add new SIDs after a token has been created). Restricted and unrestricted services (explained later in this section) always have a service SID in the hosting process's token.

EXPERIMENT: Understanding Service SIDs

In Chapter 9, we presented an experiment (“Understanding the security of the VM worker process and the virtual hard disk files”) in which we showed how the system generates VM SIDs for different VM worker processes. Similar to the VM worker process, the system generates Service SIDs using a well-defined algorithm. This experiment uses Process Explorer to show service SIDs and explains how the system generates them.

First, you need to choose a service that runs with a virtual service account or under a restricted/nonrestricted access token. Open the Registry Editor (by typing **regedit** in the Cortana search box) and navigate to the HKLM\SYSTEM\CurrentControlSet\Services registry key. Then select **Find** from the **Edit** menu. As discussed previously in this section, the service account is stored in the *ObjectName* registry value. Unfortunately, you would not find a lot of services running in a virtual service account (those accounts begin with the NT SERVICE\ virtual domain), so it is better if you look at a restricted token (unrestricted tokens work, too). Type *ServiceSidType* (the value of which is stored whether the Service should run with a restricted or unrestricted token) and click the **Find Next** button.

For this experiment, you are looking for a restricted service account (which has the *ServiceSidType* value set to 3), but unrestricted services work well, too (the value is set to 1). If the desired value does not match, you can use the **F3** button to find the next service. In this experiment, use the BFE service.

Open Process Explorer, search the BFE hosting process (refer to the previous experiment for understanding how to find the correct one), and double-click it. Select the **Security** tab and click the NT SERVICE\BFE Group (the human-readable notation of the service SID) or the service SID of your service if you have chosen another one. Note the extended group SID, which appears under the group list (if the service is running under a virtual service account, the service SID is instead shown by Process Explorer in the second line of the Security Tab):

```
S-1-5-80-1383147646-27650227-2710666058-1662982300-1023958487
```

The NT authority (ID 5) is responsible for the service SIDs, generated by using the service base RID (80) and by the SHA-1 hash of the uppercase UTF-16 Unicode string of the service name. SHA-1 is an algorithm that produces a 160-bit (20-bytes) value. In the Windows security world, this means that the SID will have 5 (4-bytes) sub-authority values. The SHA-1 hash of the Unicode (UTF-16) BFE service name is:

```
7e 28 71 52 b3 e8 a5 01 4a 7b 91 a1 9c 18 1f 63 d7 5d 08 3d
```

If you divide the produced hash in five groups of eight hexadecimal digits, you will find the following:

- 0x5271287E (first DWORD value), which equals 1383147646 in decimal (remember that Windows is a little endian OS)
- 0x01A5E8B3 (second DWORD value), which equals 27650227 in decimal

- 0xA1917B4A (third DWORD value), which equals 2710666058 in decimal
- 0x631F189C (fourth DWORD value), which equals 1662982300 in decimal
- 0x3D085DD7 (fifth DWORD value), which equals 1023958487 in decimal

If you combine the numbers and add the service SID authority value and first RID (S-1-5-80), you build the same SID shown by Process Explorer. This demonstrates how the system generates service SIDs.

The usefulness of having a SID for each service extends beyond the mere ability to add ACL entries and permissions for various objects on the system as a way to have fine-grained control over their access. Our discussion initially covered the case in which certain objects on the system, accessible by a given account, must be protected from a service running within that same account. As we've previously described, service SIDs prevent that problem only by requiring that Deny entries associated with the service SID be placed on every object that needs to be secured, which is a clearly an unmanageable approach.

To avoid requiring *Deny* access control entries (ACEs) as a way to prevent services from having access to resources that the user account in which they run does have access, there are two types of service SIDs: the restricted service SID (*SERVICE_SID_TYPE_RESTRICTED*) and the unrestricted service SID (*SERVICE_SID_TYPE_UNRESTRICTED*), the latter being the default and the case we've looked at up to now. The names are a little misleading in this case. The service SID is always generated in the same way (see the previous experiment). It is the token of the hosting process that is generated in a different way.

Unrestricted service SIDs are created as enabled-by-default, group owner SIDs, and the process token is also given a new ACE that provides full permission to the service logon SID, which allows the service to continue communicating with the SCM. (A primary use of this would be to enable or disable service SIDs inside the process during service startup or shutdown.) A service running with the SYSTEM account launched with an unrestricted token is even more powerful than a standard SYSTEM service.

A restricted service SID, on the other hand, turns the service-hosting process's token into a write-restricted token. Restricted tokens (see Chapter 7 of Part 1 for more information on tokens) generally require the system to perform two access checks while accessing securable objects: one using the standard token's enabled group SIDs list, and another using the list of restricted SIDs. For a standard restricted token, access is granted only if both access checks allow the requested access rights. On the other hand, write-restricted tokens (which are usually created by specifying the *WRITE_RESTRICTED* flag to the *CreateRestrictedToken* API) perform the double access checks only for write requests: read-only access requests raise just one access check on the token's enabled group SIDs as for regular tokens.

The service host process running with a write-restricted token can write only to objects granting explicit write access to the service SID (and the following three supplemental SIDs added for compatibility), regardless of the account it's running. Because of this, all services running inside that process (part of the same service group) must have the restricted SID type; otherwise, services with the restricted SID type fail to start. Once the token becomes write-restricted, three more SIDs are added for compatibility reasons:

- The world SID is added to allow write access to objects that are normally accessible by anyone anyway, most importantly certain DLLs in the load path.
- The service logon SID is added to allow the service to communicate with the SCM.
- The write-restricted SID is added to allow objects to explicitly allow any write-restricted service write access to them. For example, ETW uses this SID on its objects to allow any write-restricted service to generate events.

Figure 10-11 shows an example of a service-hosting process containing services that have been marked as having restricted service SIDs. For example, the Base Filtering Engine (BFE), which is responsible for applying Windows Firewall filtering rules, is part of this hosting process because these rules are stored in registry keys that must be protected from malicious write access should a service be compromised. (This could allow a service exploit to disable the outgoing traffic firewall rules, enabling bidirectional communication with an attacker, for example.)

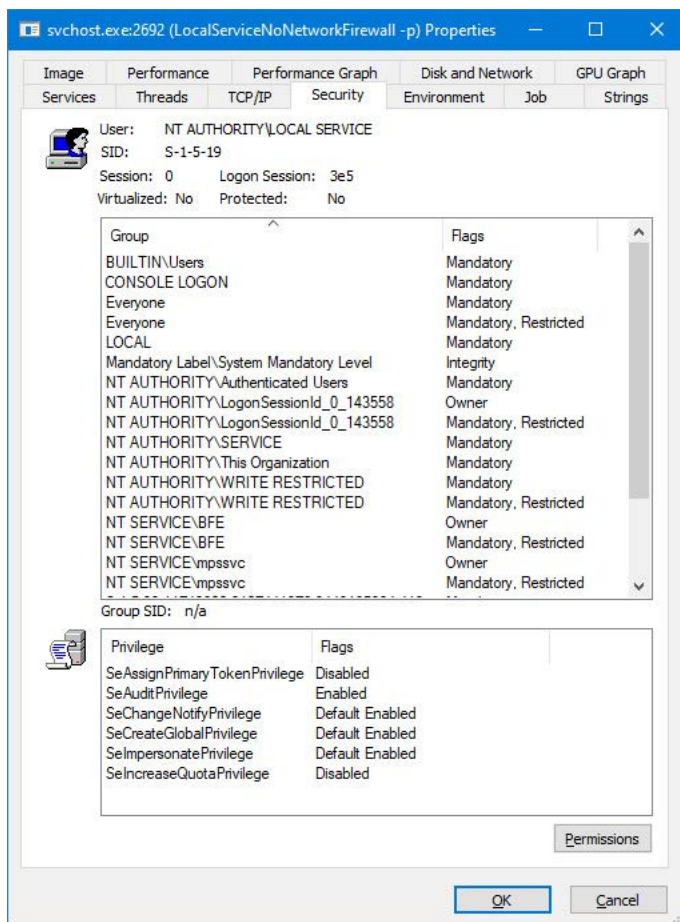

FIGURE 10-11 Service with restricted SIDs.

By blocking write access to objects that would otherwise be writable by the service (through inheriting the permissions of the account it is running as), restricted service SIDs solve the other side of the problem we initially presented because users do not need to do anything to prevent a service running in a privileged account from having write access to critical system files, registry keys, or other objects, limiting the attack exposure of any such service that might have been compromised.

Windows also allows for firewall rules that reference service SIDs linked to one of the three behaviors described in Table 10-11.

TABLE 10-11 Network restriction rules

Scenario	Example	Restrictions
Network access blocked	The shell hardware detection service (ShellHWDetection).	All network communications are blocked (both incoming and outgoing).
Network access statically port-restricted	The RPC service (Rpcss) operates on port 135 (TCP and UDP).	Network communications are restricted to specific TCP or UDP ports.
Network access dynamically port-restricted	The DNS service (Dns) listens on variable ports (UDP).	Network communications are restricted to configurable TCP or UDP ports.

The virtual service account

As introduced in the previous section, a service SID also can be set as the owner of the token of a service running in the context of a virtual service account. A service running with a virtual service account has fewer privileges than the LocalService or NetworkService service types (refer to Table 10-10 for the list of privileges) and no credentials available to authenticate it through the network. The Service SID is the token's owner, and the token is part of the Everyone, Users, Authenticated Users, and All Services groups. This means that the service can read (or write, unless the service uses a restricted SID type) objects that belong to standard users but not to high-privileged ones belonging to the Administrator or System group. Unlike the other types, a service running with a virtual service account has a private profile, which is loaded by the ProfSvc service (Profsvc.dll) during service logon, in a similar way as for regular services (more details in the "Service logon" section). The profile is initially created during the first service logon using a folder with the same name as the service located in the %SystemRoot%\ServiceProfiles path. When the service's profile is loaded, its registry hive is mounted in the HKEY_USERS root key, under a key named as the virtual service account's human readable SID (starting with S-1-5-80 as explained in the "Understanding service SIDs" experiment).

Users can easily assign a virtual service account to a service by setting the log-on account to NT SERVICE*<ServiceName>*, where *<ServiceName>* is the name of the service. At logon time, the Service Control Manager recognizes that the log-on account is a virtual service account (thanks to the NT SERVICE logon provider) and verifies that the account's name corresponds to the name of the service. A service can't be started using a virtual service account that belongs to another one, and this is enforced by SCM (through the internal *SclsValidAccountName* function). Services that share a host process cannot run with a virtual service account.

While operating with securable objects, users can add to the object's ACL using the service log-on account (in the form of NT SERVICE*<ServiceName>*), an ACE that allows or denies access to a virtual

service. As shown in Figure 10-12, the system is able to translate the virtual service account's name to the proper SID, thus establishing fine-grained access control to the object from the service. (This also works for regular services running with a nonsystem account, as explained in the previous section.)

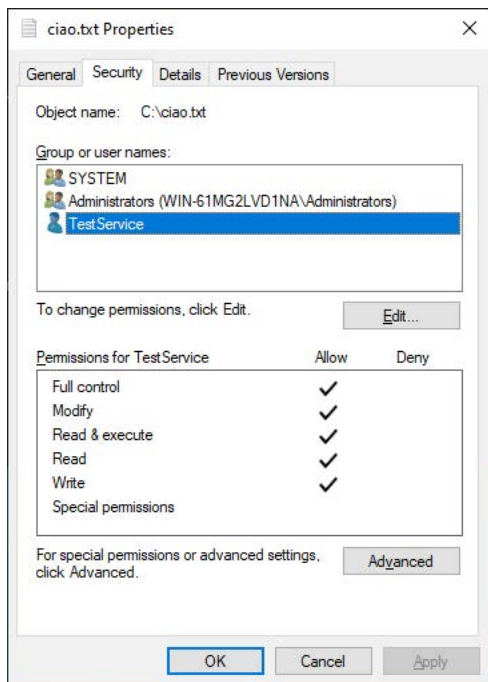

FIGURE 10-12 A file (securable object) with an ACE allowing full access to the TestService.

Interactive services and Session 0 Isolation

One restriction for services running under a proper service account, the local system, local service, and network service accounts that has always been present in Windows is that these services could not display dialog boxes or windows on the interactive user's desktop. This limitation wasn't the direct result of running under these accounts but rather a consequence of the way the Windows subsystem assigns service processes to window stations. This restriction is further enhanced by the use of sessions, in a model called Session 0 Isolation, a result of which is that services cannot directly interact with a user's desktop.

The Windows subsystem associates every Windows process with a window station. A window station contains desktops, and desktops contain windows. Only one window station can be visible at a time and receive user mouse and keyboard input. In a Terminal Services environment, one window station per session is visible, but services all run as part of the hidden session 0. Windows names the visible window station WinSta0, and all interactive processes access WinSta0.

Unless otherwise directed, the Windows subsystem associates services running within the proper service account or the local system account with a nonvisible window station named Service-0x0-3e7\$ that all noninteractive services share. The number in the name, 3e7, represents the logon session identifier that the Local Security Authority process (LSASS) assigns to the logon session the SCM uses

for noninteractive services running in the local system account. In a similar way, services running in the Local service account are associated with the window station generated by the logon session 3e5, while services running in the network service account are associated with the window station generated by the logon session 3e4.

Services configured to run under a user account (that is, not the local system account) are run in a different nonvisible window station named with the LSASS logon identifier assigned for the service's logon session. Figure 10-13 shows a sample display from the Sysinternals WinObj tool that shows the object manager directory in which Windows places window station objects. Visible are the interactive window station (WinSta0) and the three noninteractive services window stations.

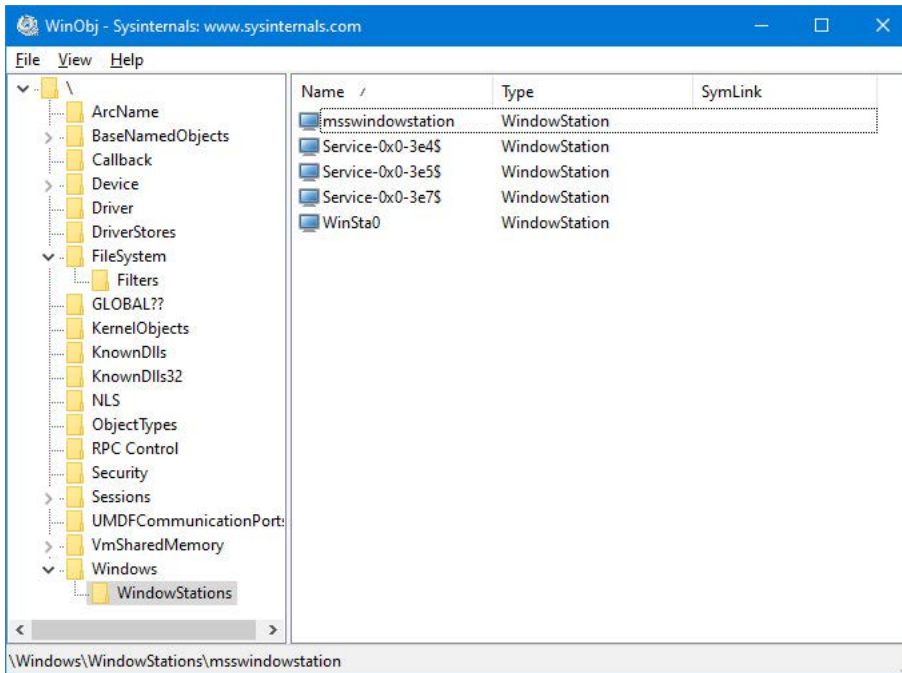

FIGURE 10-13 List of window stations.

Regardless of whether services are running in a user account, the local system account, or the local or network service accounts, services that aren't running on the visible window station can't receive input from a user or display visible windows. In fact, if a service were to pop up a modal dialog box, the service would appear hung because no user would be able to see the dialog box, which of course would prevent the user from providing keyboard or mouse input to dismiss it and allow the service to continue executing.

A service could have a valid reason to interact with the user via dialog boxes or windows. Services configured using the *SERVICE_INTERACTIVE_PROCESS* flag in the service's registry key's Type parameter are launched with a hosting process connected to the interactive WinSta0 window station. (Note that services configured to run under a user account can't be marked as interactive.) Were user processes to run in the same session as services, this connection to WinSta0 would allow the service to display dialog

boxes and windows and enable those windows to respond to user input because they would share the window station with the interactive services. However, only processes owned by the system and Windows services run in session 0; all other logon sessions, including those of console users, run in different sessions. Therefore, any window displayed by processes in session 0 is not visible to the user.

This additional boundary helps prevent shatter attacks, whereby a less-privileged application sends window messages to a window visible on the same window station to exploit a bug in a more privileged process that owns the window, which permits it to execute code in the more privileged process. In the past, Windows included the Interactive Services Detection service (UI0Detect), which notified users when a service had displayed a window on the main desktop of the WinSta0 window station of Session 0. This would allow the user to switch to the session 0's window station, making interactive services run properly. For security purposes, this feature was first disabled; since Windows 10 April 2018 Update (RS4), it has been completely removed.

As a result, even though interactive services are still supported by the Service Control Manager (only by setting the HKLM\SYSTEM\CurrentControlSet\Control\Windows\NoInteractiveServices registry value to 0), access to session 0 is no longer possible. No service can display any window anymore (at least without some undocumented hack).

The Service Control Manager (SCM)

The SCM's executable file is %SystemRoot%\System32\Services.exe, and like most service processes, it runs as a Windows console program. The Wininit process starts the SCM early during the system boot. (Refer to Chapter 12 for details on the boot process.) The SCM's startup function, *SvcCtrlMain*, orchestrates the launching of services that are configured for automatic startup.

SvcCtrlMain first performs its own initialization by setting its process secure mitigations and unhandled exception filter and by creating an in-memory representation of the well-known SIDs. It then creates two synchronization events: one named *SvcctrlStartEvent_A3752DX* and the other named *SC_AutoStartComplete*. Both are initialized as nonsignaled. The first event is signaled by the SCM after all the steps necessary to receive commands from SCPs are completed. The second is signaled when the entire initialization of the SCM is completed. The event is used for preventing the system or other users from starting another instance of the Service Control Manager. The function that an SCP uses to establish a dialog with the SCM is *OpenSCManager*. *OpenSCManager* prevents an SCP from trying to contact the SCM before the SCM has initialized by waiting for *SvcctrlStartEvent_A3752DX* to become signaled.

Next, *SvcCtrlMain* gets down to business, creates a proper security descriptor, and calls *ScGenerateServiceDB*, the function that builds the SCM's internal service database. *ScGenerateServiceDB* reads and stores the contents of HKLM\SYSTEM\CurrentControlSet\Control\ServiceGroupOrder\List, a REG_MULTI_SZ value that lists the names and order of the defined service groups. A service's registry key contains an optional *Group* value if that service or device driver needs to control its startup ordering with respect to services from other groups. For example, the Windows networking stack is built from the bottom up, so networking services must specify *Group* values that place them later in the startup sequence than networking device drivers. The SCM internally creates a group list that preserves the ordering of the groups it reads from the registry. Groups include (but are not limited to) NDIS, TDI, Primary Disk, Keyboard Port, Keyboard Class, Filters, and so on. Add-on and third-party applications

can even define their own groups and add them to the list. Microsoft Transaction Server, for example, adds a group named MS Transactions.

ScGenerateServiceDB then scans the contents of HKLM\SYSTEM\CurrentControlSet\Services, creating an entry (called “service record”) in the service database for each key it encounters. A database entry includes all the service-related parameters defined for a service as well as fields that track the service’s status. The SCM adds entries for device drivers as well as for services because the SCM starts services and drivers marked as autostart and detects startup failures for drivers marked boot-start and system-start. It also provides a means for applications to query the status of drivers. The I/O manager loads drivers marked boot-start and system-start before any user-mode processes execute, and therefore any drivers having these start types load before the SCM starts.

ScGenerateServiceDB reads a service’s Group value to determine its membership in a group and associates this value with the group’s entry in the group list created earlier. The function also reads and records in the database the service’s group and service dependencies by querying its *DependOnGroup* and *DependOnService* registry values. Figure 10-14 shows how the SCM organizes the service entry and group order lists. Notice that the service list is sorted alphabetically. The reason this list is sorted alphabetically is that the SCM creates the list from the Services registry key, and Windows enumerates registry keys alphabetically.

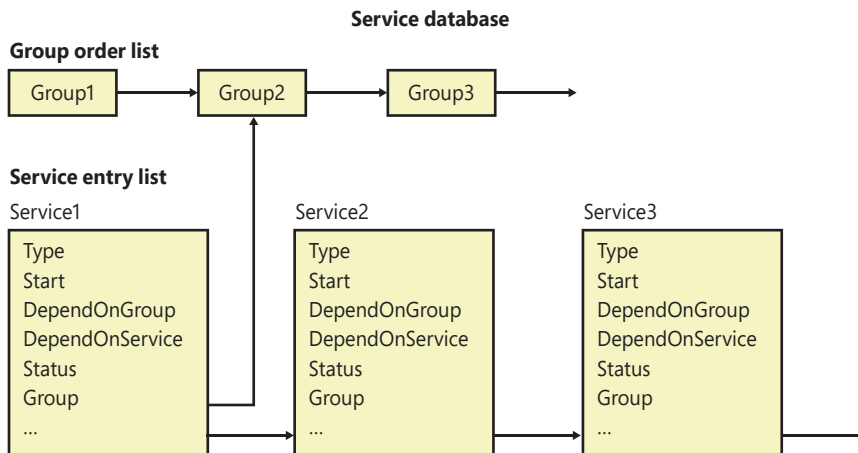

FIGURE 10-14 Organization of the service database.

During service startup, the SCM calls on LSASS (for example, to log on a service in a nonlocal system account), so the SCM waits for LSASS to signal the *LSA_RPC_SERVER_ACTIVE* synchronization event, which it does when it finishes initializing. Wininit also starts the LSASS process, so the initialization of LSASS is concurrent with that of the SCM, and the order in which LSASS and the SCM complete initialization can vary. The SCM cleans up (from the registry, other than from the database) all the services that were marked as deleted (through the *DeleteFlag* registry value) and generates the dependency list for each service record in the database. This allows the SCM to know which service is dependent on a particular service record, which is the opposite dependency information compared to the one stored in the registry.

The SCM then queries whether the system is started in safe mode (from the HKLM\System\CurrentControlSet\Control\Safeboot\Option\OptionValue registry value). This check is needed for determining later if a service should start (details are explained in the “Autostart services startup” section later in this chapter). It then creates its remote procedure call (RPC) named pipe, which is named \Pipe\Ntscvs, and then RPC launches a thread to listen on the pipe for incoming messages from SCPs. The SCM signals its initialization-complete event, *SvcctrlStartEvent_A3752DX*. Registering a console application shutdown event handler and registering with the Windows subsystem process via *RegisterServiceProcess* prepares the SCM for system shutdown.

Before starting the autostart services, the SCM performs a few more steps. It initializes the UMDf driver manager, which is responsible in managing UMDf drivers. Since Windows 10 Fall Creators Update (RS3), it’s part of the Service Control Manager and waits for the known DLLs to be fully initialized (by waiting on the \KnownDlls\SmKnownDllsInitialized event that’s signaled by Session Manager).

EXPERIMENT: Enable services logging

The Service Control Manager usually logs ETW events only when it detects abnormal error conditions (for example, while failing to start a service or to change its configuration). This behavior can be overridden by manually enabling or disabling a different kind of SCM events. In this experiment, you will enable two kinds of events that are particularly useful for debugging a service change of state. Events 7036 and 7042 are raised when a service change status or when a STOP control request is sent to a service.

Those two events are enabled by default on server SKUs but not on client editions of Windows 10. Using your Windows 10 machine, you should open the Registry Editor (by typing `regedit.exe` in the Cortana search box) and navigate to the following registry key: HKLM\SYSTEM\CurrentControlSet\Control\ScEvents. If the last subkey does not exist, you should create it by right-clicking the Control subkey and selecting the Key item from the New context menu).

Now you should create two DWORD values and name them 7036 and 7042. Set the data of the two values to 1. (You can set them to 0 to gain the opposite effect of preventing those events from being generated, even on Server SKUs.) You should get a registry state like the following one:

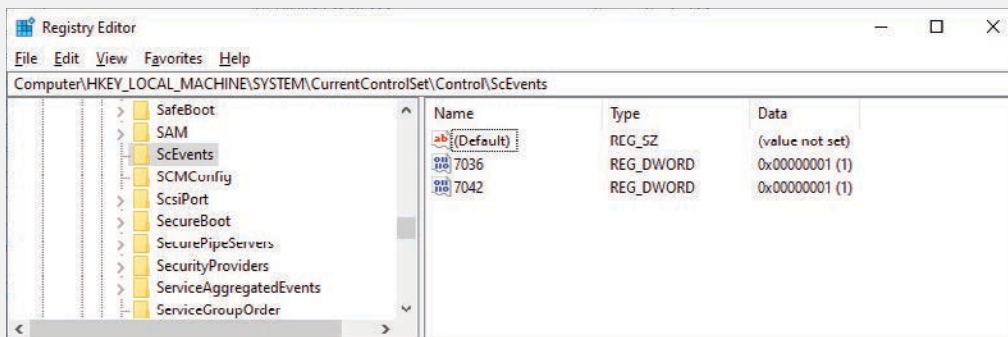

Restart your workstation, and then start and stop a service (for example, the AppXSvc service) using the `sc.exe` tool by opening an administrative command prompt and typing the following commands:

```
sc stop AppXSvc
sc start AppXSvc
```

Open the Event Viewer (by typing `eventvwr` in the Cortana search box) and navigate to **Windows Logs** and then **System**. You should note different events from the Service Control Manager with Event ID 7036 and 7042. In the top ones, you should find the stop event generated by the AppXSvc service, as shown in the following figure:

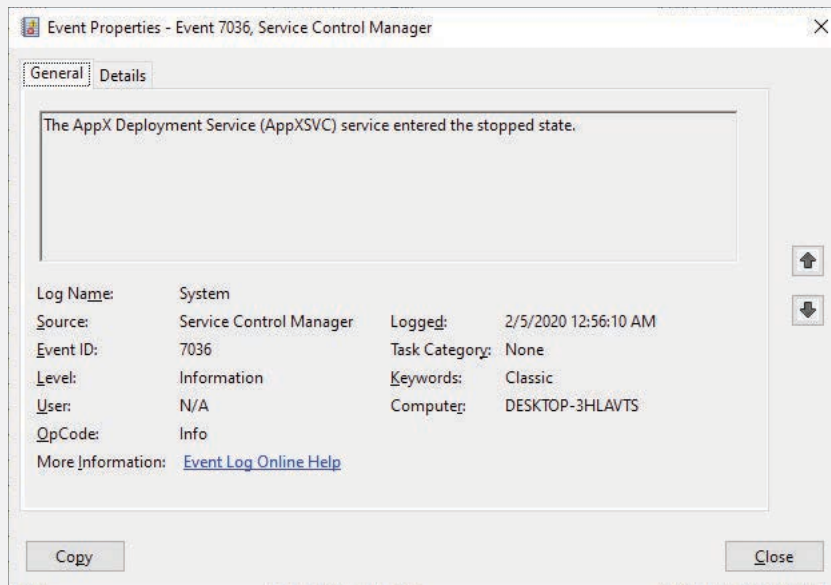

Note that the Service Control Manager by default logs all the events generated by services started automatically at system startup. This can generate an undesired number of events flooding the System event log. To mitigate the problem, you can disable SCM autostart events by creating a registry value named `EnableAutostartEvents` in the `HKLM\System\CurrentControlSet\Control` key and set it to 0 (the default implicit value is 1 in both client and server SKUs). As a result, this will log only events generated by service applications when starting, pausing, or stopping a target service.

Network drive letters

In addition to its role as an interface to services, the SCM has another totally unrelated responsibility: It notifies GUI applications in a system whenever the system creates or deletes a network drive-letter connection. The SCM waits for the Multiple Provider Router (MPR) to signal a named event, `\BaseNamedObjects\ScNetDrvMsg`, which MPR signals whenever an application assigns a drive letter to a remote network share or deletes a remote-share drive-letter assignment. When MPR signals the event, the SCM calls the *GetDriveType* Windows function to query the list of connected network drive letters. If the list changes across the event signal, the SCM sends a Windows broadcast message of type *WM_DEVICECHANGE*. The SCM uses either *DBT_DEVICEREMOVECOMPLETE* or *DBT_DEVICEARRIVAL* as the message's subtype. This message is primarily intended for Windows Explorer so that it can update any open computer windows to show the presence or absence of a network drive letter.

Service control programs

As introduced in the "Service applications" section, service control programs (SCPs) are standard Windows applications that use SCM service management functions, including *CreateService*, *OpenService*, *StartService*, *ControlService*, *QueryServiceStatus*, and *DeleteService*. To use the SCM functions, an SCP must first open a communications channel to the SCM by calling the *OpenSCManager* function to specify what types of actions it wants to perform. For example, if an SCP simply wants to enumerate and display the services present in the SCM's database, it requests *enumerate-service* access in its call to *OpenSCManager*. During its initialization, the SCM creates an internal object that represents the SCM database and uses the Windows security functions to protect the object with a security descriptor that specifies what accounts can open the object with what access permissions. For example, the security descriptor indicates that the Authenticated Users group can open the SCM object with *enumerate-service* access. However, only administrators can open the object with the access required to create or delete a service.

As it does for the SCM database, the SCM implements security for services themselves. When an SCP creates a service by using the *CreateService* function, it specifies a security descriptor that the SCM associates internally with the service's entry in the service database. The SCM stores the security descriptor in the service's registry key as the *Security* value, and it reads that value when it scans the registry's *Services* key during initialization so that the security settings persist across reboots. In the same way that an SCP must specify what types of access it wants to the SCM database in its call to *OpenSCManager*, an SCP must tell the SCM what access it wants to a service in a call to *OpenService*. Accesses that an SCP can request include the ability to query a service's status and to configure, stop, and start a service.

The SCP you're probably most familiar with is the Services MMC snap-in that's included in Windows, which resides in `%SystemRoot%\System32\Filemgmt.dll`. Windows also includes *Sc.exe* (Service Controller tool), a command-line service control program that we've mentioned multiple times.

SCPs sometimes layer service policy on top of what the SCM implements. A good example is the timeout that the Services MMC snap-in implements when a service is started manually. The snap-in presents a progress bar that represents the progress of a service's startup. Services indirectly interact with SCPs by setting their configuration status to reflect their progress as they respond to SCM

commands such as the start command. SCPs query the status with the *QueryServiceStatus* function. They can tell when a service actively updates the status versus when a service appears to be hung, and the SCM can take appropriate actions in notifying a user about what the service is doing.

Autostart services startup

SvcCtrlMain invokes the SCM function *ScAutoStartServices* to start all services that have a *Start* value designating autostart (except delayed autostart and user services). *ScAutoStartServices* also starts autostart drivers. To avoid confusion, you should assume that the term *services* means services and drivers unless indicated otherwise. *ScAutoStartServices* begins by starting two important and basic services, named Plug and Play (implemented in the *Umpnpgmgr.dll* library) and Power (implemented in the *Umpo.dll* library), which are needed by the system for managing plug-and-play hardware and power interfaces. The SCM then registers its Autostart WNF state, used to indicate the current autostart phase to the Power and other services.

Before the starting of other services can begin, the *ScAutoStartService* routine calls *ScGetBootAndSystemDriverState* to scan the service database looking for boot-start and system-start device driver entries. *ScGetBootAndSystemDriverState* determines whether a driver with the start type set to Boot Start or System Start successfully started by looking up its name in the object manager namespace directory named *\Driver*. When a device driver successfully loads, the I/O manager inserts the driver's object in the namespace under this directory, so if its name isn't present, it hasn't loaded. Figure 10-15 shows WinObj displaying the contents of the *Driver* directory. *ScGetBootAndSystemDriverState* notes the names of drivers that haven't started and that are part of the current profile in a list named *ScStoppedDrivers*. The list will be used later at the end of the SCM initialization for logging an event to the system event log (ID 7036), which contains the list of boot drivers that have failed to start.

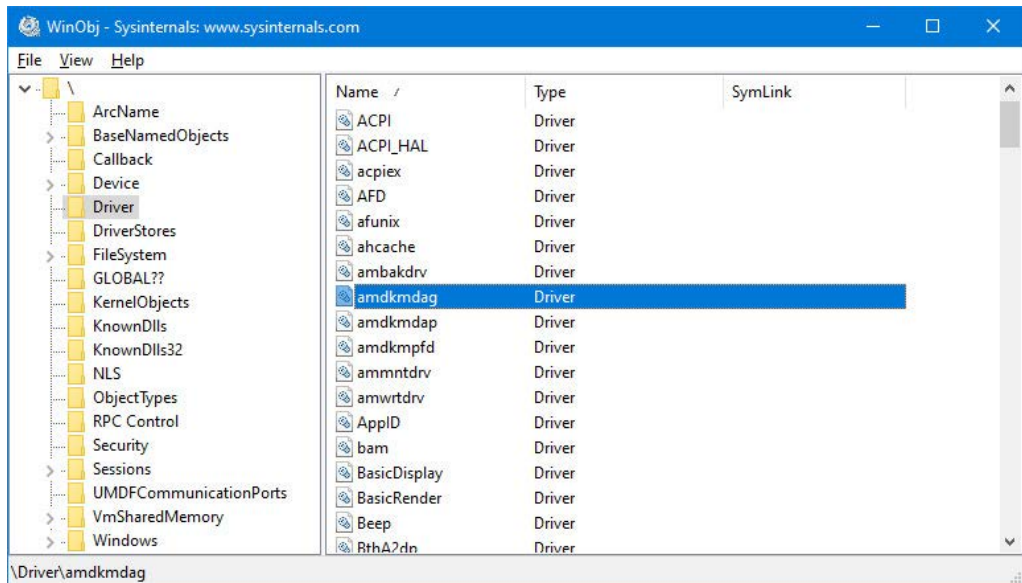

FIGURE 10-15 List of driver objects.

The algorithm in *ScAutoStartServices* for starting services in the correct order proceeds in phases, whereby a phase corresponds to a group and phases proceed in the sequence defined by the group ordering stored in the HKLM\SYSTEM\CurrentControlSet\Control\ServiceGroupOrder\List registry value. The *List* value, shown in Figure 10-16, includes the names of groups in the order that the SCM should start them. Thus, assigning a service to a group has no effect other than to fine-tune its startup with respect to other services belonging to different groups.

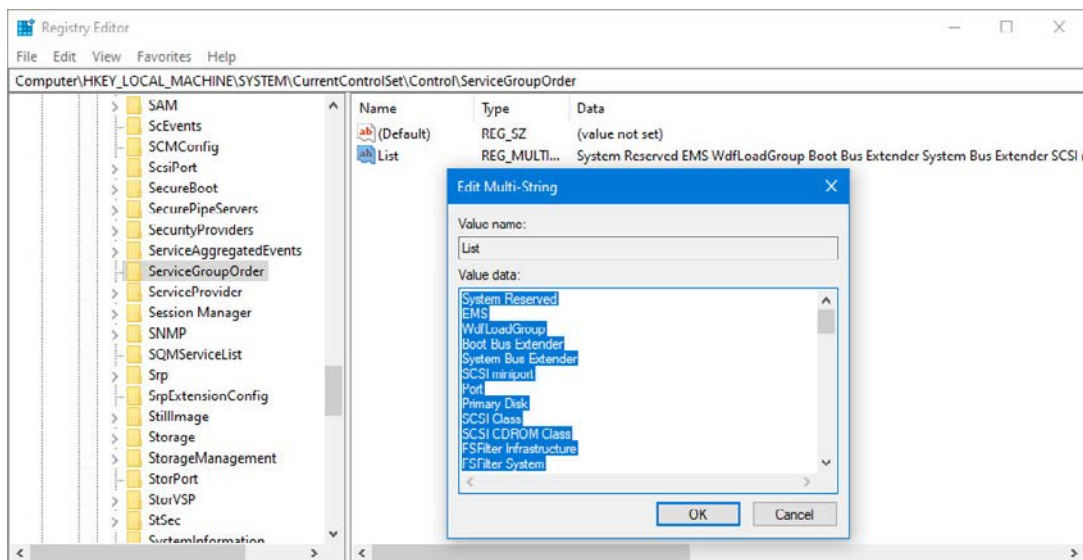

FIGURE 10-16 ServiceGroupOrder registry key.

When a phase starts, *ScAutoStartServices* marks all the service entries belonging to the phase's group for startup. Then *ScAutoStartServices* loops through the marked services to see whether it can start each one. Part of this check includes seeing whether the service is marked as delayed autostart or a user template service; in both cases, the SCM will start it at a later stage. (Delayed autostart services must also be ungrouped. User services are discussed later in the "User services" section.) Another part of the check it makes consists of determining whether the service has a dependency on another group, as specified by the existence of the *DependOnGroup* value in the service's registry key. If a dependency exists, the group on which the service is dependent must have already initialized, and at least one service of that group must have successfully started. If the service depends on a group that starts later than the service's group in the group startup sequence, the SCM notes a "circular dependency" error for the service. If *ScAutoStartServices* is considering a Windows service or an autostart device driver, it next checks to see whether the service depends on one or more other services; if it is dependent, it determines whether those services have already started. Service dependencies are indicated with the *DependOnService* registry value in a service's registry key. If a service depends on other services that belong to groups that come later in the ServiceGroupOrder\List, the SCM also generates a "circular dependency" error and doesn't start the service. If the service depends on any services from the same group that haven't yet started, the service is skipped.

When the dependencies of a service have been satisfied, *ScAutoStartServices* makes a final check to see whether the service is part of the current boot configuration before starting the service. When the system is booted in safe mode, the SCM ensures that the service is either identified by name or by group in the appropriate safe boot registry key. There are two safe boot keys, *Minimal* and *Network*, under HKLM\SYSTEM\CurrentControlSet\Control\SafeBoot, and the one that the SCM checks depends on what safe mode the user booted. If the user chose Safe Mode or Safe Mode With Command Prompt at the modern or legacy boot menu, the SCM references the *Minimal* key; if the user chose Safe Mode With Networking, the SCM refers to *Network*. The existence of a string value named *Option* under the *SafeBoot* key indicates not only that the system booted in safe mode but also the type of safe mode the user selected. For more information about safe boots, see the section “Safe mode” in Chapter 12.

Service start

Once the SCM decides to start a service, it calls *StartInternal*, which takes different steps for services than for device drivers. When *StartInternal* starts a Windows service, it first determines the name of the file that runs the service’s process by reading the *ImagePath* value from the service’s registry key. If the service file corresponds to LSASS.exe, the SCM initializes a control pipe, connects to the already-running LSASS process, and waits for the LSASS process response. When the pipe is ready, the LSASS process connects to the SCM by calling the classical *StartServiceCtrlDispatcher* routine. As shown in Figure 10-17, some services like Credential Manager or Encrypting File System need to cooperate with the Local Security Authority Subsystem Service (LSASS)—usually for performing cryptography operation for the local system policies (like passwords, privileges, and security auditing. See Chapter 7 of Part 1 for more details).

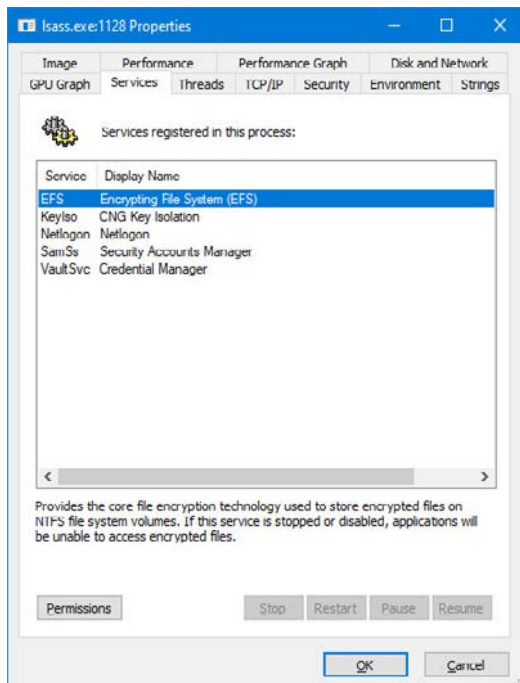

FIGURE 10-17 Services hosted by the Local Security Authority Subsystem Service (LSASS) process.

The SCM then determines whether the service is critical (by analyzing the *FailureAction* registry value) or is running under WoW64. (If the service is a 32-bit service, the SCM should apply file system redirection. See the “WoW64” section of Chapter 8 for more details.) It also examines the service’s *Type* value. If the following conditions apply, the SCM initiates a search in the internal Image Record Database:

- The service type value includes *SERVICE_WINDOWS_SHARE_PROCESS* (0x20).
- The service has not been restarted after an error.
- Svchost service splitting is not allowed for the service (see the “Svchost service splitting” section later in this chapter for further details).

An Image record is a data structure that represents a launched process hosting at least one service. If the preceding conditions apply, the SCM searches an image record that has the same process executable’s name as the new service ImagePath value.

If the SCM locates an existing image database entry with matching ImagePath data, the service can be shared, and one of the hosting processes is already running. The SCM ensures that the found hosting process is logged on using the same account as the one specified for the service being started. (This is to ensure that the service is not configured with the wrong account, such as a LocalService account, but with an image path pointing to a running Svchost, such as netsvcs, which runs as LocalSystem.) A service’s *ObjectName* registry value stores the user account in which the service should run. A service with no *ObjectName* or an *ObjectName* of LocalSystem runs in the local system account. A process can be logged on as only one account, so the SCM reports an error when a service specifies a different account name than another service that has already started in the same process.

If the image record exists, before the new service can be run, another final check should be performed: The SCM opens the token of the currently executing host process and checks whether the necessary service SID is located in the token (and all the required privileges are enabled). Even in this case, the SCM reports an error if the condition is not verified. Note that, as we describe in the next section (“Service logon”), for shared services, all the SIDs of the hosted services are added at token creation time. It is not possible for any user-mode component to add group SIDs in a token after the token has already been created.

If the image database doesn’t have an entry for the new service ImagePath value, the SCM creates one. When the SCM creates a new entry, it stores the logon account name used for the service and the data from the service’s ImagePath value. The SCM requires services to have an ImagePath value. If a service doesn’t have an ImagePath value, the SCM reports an error stating that it couldn’t find the service’s path and isn’t able to start the service. After the SCM creates an image record, it logs on the service account and starts the new hosting process. (The procedure is described in the next section, “Service logon.”)

After the service has been logged in, and the host process correctly started, the SCM waits for the initial “connection” message from the service. The service connects to SCM thanks to the SCM RPC pipe (\Pipe\Ntscvcs, as described in the “The Service Control Manager” section) and to a Channel Context data structure built by the *LogonAndStartImage* routine. When the SCM receives the first message, it proceeds to start the service by posting a *SERVICE_CONTROL_START* control message to the service process. Note that in the described communication protocol is always the service that connects to SCM.

The service application is able to process the message thanks to the message loop located in the *StartServiceCtrlDispatcher* API (see the “Service applications” section earlier in this chapter for more details). The service application enables the service group SID in its token (if needed) and creates the new service thread (which will execute the *Service Main* function). It then calls back into the SCM for creating a handle to the new service, storing it in an internal data structure (*INTERNAL_DISPATCH_TABLE*) similar to the service table specified as input to the *StartServiceCtrlDispatcher* API. The data structure is used for tracking the active services in the hosting process. If the service fails to respond positively to the start command within the timeout period, the SCM gives up and notes an error in the system Event Log that indicates the service failed to start in a timely manner.

If the service the SCM starts with a call to *StartInternal* has a *Type* registry value of *SERVICE_KERNEL_DRIVER* or *SERVICE_FILE_SYSTEM_DRIVER*, the service is really a device driver, so *StartInternal* enables the load driver security privilege for the SCM process and then invokes the kernel service *NtLoadDriver*, passing in the data in the *ImagePath* value of the driver’s registry key. Unlike services, drivers don’t need to specify an *ImagePath* value, and if the value is absent, the SCM builds an image path by appending the driver’s name to the string *%SystemRoot%\System32\Drivers*.



Note A device driver with the start value of *SERVICE_AUTO_START* or *SERVICE_DEMAND_START* is started by the SCM as a runtime driver, which implies that the resulting loaded image uses shared pages and has a control area that describes them. This is different than drivers with the start value of *SERVICE_BOOT_START* or *SERVICE_SYSTEM_START*, which are loaded by the Windows Loader and started by the I/O manager. Those drivers all use private pages and are neither sharable nor have an associated Control Area.

More details are available in Chapter 5 in Part 1.

ScAutoStartServices continues looping through the services belonging to a group until all the services have either started or generated dependency errors. This looping is the SCM’s way of automatically ordering services within a group according to their *DependOnService* dependencies. The SCM starts the services that other services depend on in earlier loops, skipping the dependent services until subsequent loops. Note that the SCM ignores *Tag* values for Windows services, which you might come across in subkeys under the *HKLM\SYSTEM\CurrentControlSet\Services* key; the I/O manager honors *Tag* values to order device driver startup within a group for boot-start and system-start drivers. Once the SCM completes phases for all the groups listed in the *ServiceGroupOrder\List* value, it performs a phase for services belonging to groups not listed in the value and then executes a final phase for services without a group.

After handling autostart services, the SCM calls *ScInitDelayStart*, which queues a delayed work item associated with a worker thread responsible for processing all the services that *ScAutoStartServices* skipped because they were marked delayed autostart (through the *DelayedAutostart* registry value). This worker thread will execute after the delay. The default delay is 120 seconds, but it can be overridden by the creating an *AutoStartDelay* value in *HKLM\SYSTEM\CurrentControlSet\Control*. The SCM performs the same actions as those executed during startup of nondelayed autostart services.

When the SCM finishes starting all autostart services and drivers, as well as setting up the delayed autostart work item, the SCM signals the event `\BaseNamedObjects\SC_AutoStartComplete`. This event is used by the Windows Setup program to gauge startup progress during installation.

Service logon

During the start procedure, if the SCM does not find any existing image record, it means that the host process needs to be created. Indeed, the new service is not shareable, it's the first one to be executed, it has been restarted, or it's a user service. Before starting the process, the SCM should create an access token for the service host process. The *LogonAndStartImage* function's goal is to create the token and start the service's host process. The procedure depends on the type of service that will be started.

User services (more precisely user service instances) are started by retrieving the current logged-on user token (through functions implemented in the `UserMgr.dll` library). In this case, the *LogonAndStartImage* function duplicates the user token and adds the "WIN://ScmUserService" security attribute (the attribute value is usually set to 0). This security attribute is used primarily by the Service Control Manager when receiving connection requests from the service. Although SCM can recognize a process that's hosting a classical service through the service SID (or the System account SID if the service is running under the Local System Account), it uses the SCM security attribute for identifying a process that's hosting a user service.

For all other type of services, the SCM reads the account under which the service will be started from the registry (from the *ObjectName* value) and calls *ScCreateServiceSids* with the goal to create a service SID for each service that will be hosted by the new process. (The SCM cycles between each service in its internal service database.) Note that if the service runs under the LocalSystem account (with no restricted nor unrestricted SID), this step is not executed.

The SCM logs on services that don't run in the System account by calling the LSASS function *LogonUserExEx*. *LogonUserExEx* normally requires a password, but normally the SCM indicates to LSASS that the password is stored as a service's LSASS "secret" under the key `HKLM\SECURITY\Policy\Secrets` in the registry. (Keep in mind that the contents of SECURITY aren't typically visible because its default security settings permit access only from the System account.) When the SCM calls *LogonUserExEx*, it specifies a service logon as the logon type, so LSASS looks up the password in the *Secrets* subkey that has a name in the form `_SC_<Service Name>`.



Note Services running with a virtual service account do not need a password for having their service token created by the LSA service. For those services, the SCM does not provide any password to the *LogonUserExEx* API.

The SCM directs LSASS to store a logon password as a secret using the *LsaStorePrivateData* function when an SCP configures a service's logon information. When a logon is successful, *LogonUserEx* returns a handle to an access token to the caller. The SCM adds the necessary service SIDs to the returned token, and, if the new service uses restricted SIDs, invokes the *ScMakeServiceTokenWriteRestricted*

function, which transforms the token in a write-restricted token (adding the proper restricted SIDs). Windows uses access tokens to represent a user's security context, and the SCM later associates the access token with the process that implements the service.

Next, the SCM creates the user environment block and security descriptor to associate with the new service process. In case the service that will be started is a packaged service, the SCM reads all the package information from the registry (package full name, origin, and application user model ID) and calls the Appinfo service, which stamps the token with the necessary AppModel security attributes and prepares the service process for the modern package activation. (See the "Packaged applications" section in Chapter 8 for more details about the AppModel.)

After a successful logon, the SCM loads the account's profile information, if it's not already loaded, by calling the User Profile Basic Api DLL's (%SystemRoot%\System32\Profapi.dll) *LoadProfileBasic* function. The value HKLM\SOFTWARE\Microsoft\Windows NT\CurrentVersion\ProfileList*<user profile key>*\ProfileImagePath contains the location on disk of a registry hive that *LoadUserProfile* loads into the registry, making the information in the hive the HKEY_CURRENT_USER key for the service.

As its next step, *LogonAndStartImage* proceeds to launch the service's process. The SCM starts the process in a suspended state with the *CreateProcessAsUser* Windows function. (Except for a process hosting services under a local system account, which are created through the standard *CreateProcess* API. The SCM already runs with a SYSTEM token, so there is no need of any other logon.)

Before the process is resumed, the SCM creates the communication data structure that allows the service application and the SCM to communicate through asynchronous RPCs. The data structure contains a control sequence, a pointer to a control and response buffer, service and hosting process data (like the PID, the service SID, and so on), a synchronization event, and a pointer to the async RPC state.

The SCM resumes the service process via the *ResumeThread* function and waits for the service to connect to its SCM pipe. If it exists, the registry value HKLM\SYSTEM\CurrentControlSet\Control\ServicesPipeTimeout determines the length of time that the SCM waits for a service to call *StartServiceCtrlDispatcher* and connect before it gives up, terminates the process, and concludes that the service failed to start (note that in this case the SCM terminates the process, unlike when the service doesn't respond to the start request, discussed previously in the "Service start" section). If *ServicesPipeTimeout* doesn't exist, the SCM uses a default timeout of 30 seconds. The SCM uses the same timeout value for all its service communications.

Delayed autostart services

Delayed autostart services enable Windows to cope with the growing number of services that are being started when a user logs on, which bogs down the boot-up process and increases the time before a user is able to get responsiveness from the desktop. The design of autostart services was primarily intended for services required early in the boot process because other services depend on them, a good example being the RPC service, on which all other services depend. The other use was to allow unattended startup of a service, such as the Windows Update service. Because many autostart

services fall in this second category, marking them as delayed autostart allows critical services to start faster and for the user's desktop to be ready sooner when a user logs on immediately after booting. Additionally, these services run in background mode, which lowers their thread, I/O, and memory priority. Configuring a service for delayed autostart requires calling the *ChangeServiceConfig2* API. You can check the state of the flag for a service by using the **qc** option of *sc.exe*.



Note If a nondelayed autostart service has a delayed autostart service as one of its dependencies, the delayed autostart flag is ignored and the service is started immediately to satisfy the dependency.

Triggered-start services

Some services need to be started on demand, after certain system events occur. For that reason, Windows 7 introduced the concept of triggered-start service. A service control program can use the *ChangeServiceConfig2* API (by specifying the *SERVICE_CONFIG_TRIGGER_INFO* information level) for configuring a demand-start service to be started (or stopped) after one or more system events occur. Examples of system events include the following:

- A specific device interface is connected to the system.
- The computer joins or leaves a domain.
- A TCP/IP port is opened or closed in the system firewall.
- A machine or user policy has been changed.
- An IP address on the network TCP/IP stack becomes available or unavailable.
- A RPC request or Named pipe packet arrives on a particular interface.
- An ETW event has been generated in the system.

The first implementation of triggered-start services relied on the Unified Background Process Manager (see the next section for details). Windows 8.1 introduced the Broker Infrastructure, which had the main goal of managing multiple system events targeted to Modern apps. All the previously listed events have been thus begun to be managed by mainly three brokers, which are all parts of the Broker Infrastructure (with the exception of the Event Aggregation): Desktop Activity Broker, System Event Broker, and the Event Aggregation. More information on the Broker Infrastructure is available in the “Packaged applications” section of Chapter 8.

After the first phase of *ScAutoStartServices* is complete (which usually starts critical services listed in the *HKLM\SYSTEM\CurrentControlSet\Control\EarlyStartServices* registry value), the SCM calls *ScRegisterServicesForTriggerAction*, the function responsible in registering the triggers for each triggered-start service. The routine cycles between each Win32 service located in the SCM database. For each service, the function generates a temporary WNF state name (using the *NtCreateWnfStateName*

native API), protected by a proper security descriptor, and publishes it with the service status stored as state data. (WNF architecture is described in the “Windows Notification Facility” section of Chapter 8.) This WNF state name is used for publishing services status changes. The routine then queries all the service triggers from the *TriggerInfo* registry key, checking their validity and bailing out in case no triggers are available.



Note The list of supported triggers, described previously, together with their parameters, is documented at https://docs.microsoft.com/en-us/windows/win32/api/winsvc/ns-winsvc-service_trigger.

If the check succeeded, for each trigger the SCM builds an internal data structure containing all the trigger information (like the targeted service name, SID, broker name, and trigger parameters) and determines the correct broker based on the trigger type: external devices events are managed by the System Events broker, while all the other types of events are managed by the Desktop Activity broker. The SCM at this stage is able to call the proper broker registration routine. The registration process is private and depends on the broker: multiple private WNF state names (which are broker specific) are generated for each trigger and condition.

The Event Aggregation broker is the glue between the private WNF state names published by the two brokers and the Service Control Manager. It subscribes to all the WNF state names corresponding to the triggers and the conditions (by using the *RtlSubscribeWnfStateChangeNotification* API). When enough WNF state names have been signaled, the Event Aggregation calls back the SCM, which can start or stop the triggered start service.

Differently from the WNF state names used for each trigger, the SCM always independently publishes a WNF state name for each Win32 service whether or not the service has registered some triggers. This is because an SCP can receive notification when the specified service status changes by invoking the *NotifyServiceStatusChange* API, which subscribes to the service’s status WNF state name. Every time the SCM raises an event that changes the status of a service, it publishes new state data to the “service status change” WNF state, which wakes up a thread running the status change callback function in the SCP.

Startup errors

If a driver or a service reports an error in response to the SCM’s startup command, the *ErrorControl* value of the service’s registry key determines how the SCM reacts. If the *ErrorControl* value is *SERVICE_ERROR_IGNORE* (0) or the *ErrorControl* value isn’t specified, the SCM simply ignores the error and continues processing service startups. If the *ErrorControl* value is *SERVICE_ERROR_NORMAL* (1), the SCM writes an event to the system Event Log that says, “The <service name> service failed to start due to the following error.” The SCM includes the textual representation of the Windows error code that the service returned to the SCM as the reason for the startup failure in the Event Log record. Figure 10-18 shows the Event Log entry that reports a service startup error.

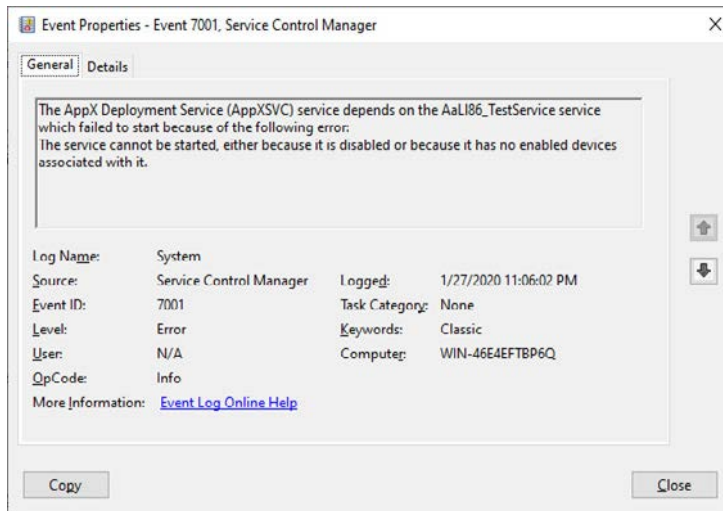

FIGURE 10-18 Service startup failure Event Log entry.

If a service with an *ErrorControl* value of *SERVICE_ERROR_SEVERE* (2) or *SERVICE_ERROR_CRITICAL* (3) reports a startup error, the SCM logs a record to the Event Log and then calls the internal function *ScRevertToLastKnownGood*. This function checks whether the last known good feature is enabled, and, if so, switches the system's registry configuration to a version, named last known good, with which the system last booted successfully. Then it restarts the system using the *NtShutdownSystem* system service, which is implemented in the executive. If the system is already booting with the last known good configuration, or if the last known good configuration is not enabled, the SCM does nothing more than emit a log event.

Accepting the boot and last known good

Besides starting services, the system charges the SCM with determining when the system's registry configuration, `HKLM\SYSTEM\CurrentControlSet`, should be saved as the last known good control set. The *CurrentControlSet* key contains the *Services* key as a subkey, so *CurrentControlSet* includes the registry representation of the SCM database. It also contains the *Control* key, which stores many kernel-mode and user-mode subsystem configuration settings. By default, a successful boot consists of a successful startup of autostart services and a successful user logon. A boot fails if the system halts because a device driver crashes the system during the boot or if an autostart service with an *ErrorControl* value of *SERVICE_ERROR_SEVERE* or *SERVICE_ERROR_CRITICAL* reports a startup error.

The last known good configuration feature is usually disabled in the client version of Windows. It can be enabled by setting the `HKLM\SYSTEM\CurrentControlSet\Control\Session Manager\ Configuration Manager\LastKnownGood\Enabled` registry value to 1. In Server SKUs of Windows, the value is enabled by default.

The SCM knows when it has completed a successful startup of the autostart services, but Winlogon (`%SystemRoot%\System32\Winlogon.exe`) must notify it when there is a successful logon. Winlogon invokes the *NotifyBootConfigStatus* function when a user logs on, and *NotifyBootConfigStatus* sends a

message to the SCM. Following the successful start of the autostart services or the receipt of the message from *NotifyBootConfigStatus* (whichever comes last), if the last known good feature is enabled, the SCM calls the system function *NtInitializeRegistry* to save the current registry startup configuration.

Third-party software developers can supersede Winlogon's definition of a successful logon with their own definition. For example, a system running Microsoft SQL Server might not consider a boot successful until after SQL Server is able to accept and process transactions. Developers impose their definition of a successful boot by writing a boot-verification program and installing the program by pointing to its location on disk with the value stored in the registry key `HKLM\SYSTEM\CurrentControlSet\Control\BootVerificationProgram`. In addition, a boot-verification program's installation must disable Winlogon's call to *NotifyBootConfigStatus* by setting `HKLM\SOFTWARE\Microsoft\Windows NT\CurrentVersion\Winlogon\ReportBootOk` to 0. When a boot-verification program is installed, the SCM launches it after finishing autostart services and waits for the program's call to *NotifyBootConfigStatus* before saving the last known good control set.

Windows maintains several copies of *CurrentControlSet*, and *CurrentControlSet* is really a symbolic registry link that points to one of the copies. The control sets have names in the form `HKLM\SYSTEM\ControlSetnnn`, where *nnn* is a number such as 001 or 002. The `HKLM\SYSTEM\Select` key contains values that identify the role of each control set. For example, if *CurrentControlSet* points to *ControlSet001*, the *Current* value under *Select* has a value of 1. The *LastKnownGood* value under *Select* contains the number of the last known good control set, which is the control set last used to boot successfully. Another value that might be on your system under the *Select* key is *Failed*, which points to the last control set for which the boot was deemed unsuccessful and aborted in favor of an attempt at booting with the last known good control set. Figure 10-19 displays a Windows Server system's control sets and *Select* values.

NtInitializeRegistry takes the contents of the last known good control set and synchronizes it with that of the *CurrentControlSet* key's tree. If this was the system's first successful boot, the last known good won't exist, and the system will create a new control set for it. If the last known good tree exists, the system simply updates it with differences between it and *CurrentControlSet*.

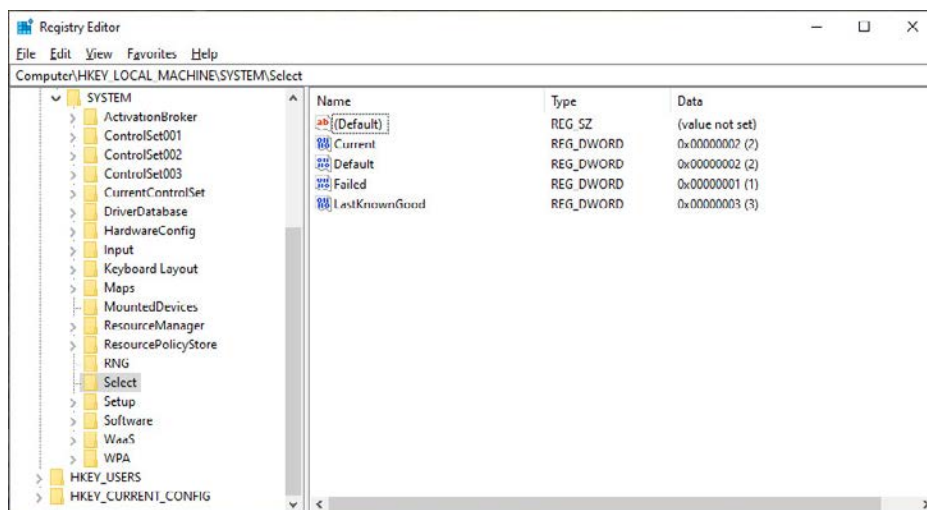

FIGURE 10-19 Control set selection key on Windows Server 2019.

Last known good is helpful in situations in which a change to CurrentControlSet, such as the modification of a system performance-tuning value under HKLM\SYSTEM\Control or the addition of a service or device driver, causes the subsequent boot to fail. Figure 10-20 shows the **Startup Settings** of the modern boot menu. Indeed, when the Last Known Good feature is enabled, and the system is in the boot process, users can select the **Startup Settings** choice in the **Troubleshoot** section of the modern boot menu (or in the Windows Recovery Environment) to bring up another menu that lets them direct the boot to use the last known good control set. (In case the system is still using the Legacy boot menu, users should press **F8** to enable the **Advanced Boot Options**.) As shown in the figure, when the **Enable Last Known Good Configuration** option is selected, the system boots by rolling the system's registry configuration back to the way it was the last time the system booted successfully. Chapter 12 describes in more detail the use of the Modern boot menu, the Windows Recovery Environment, and other recovery mechanisms for troubleshooting system startup problems.

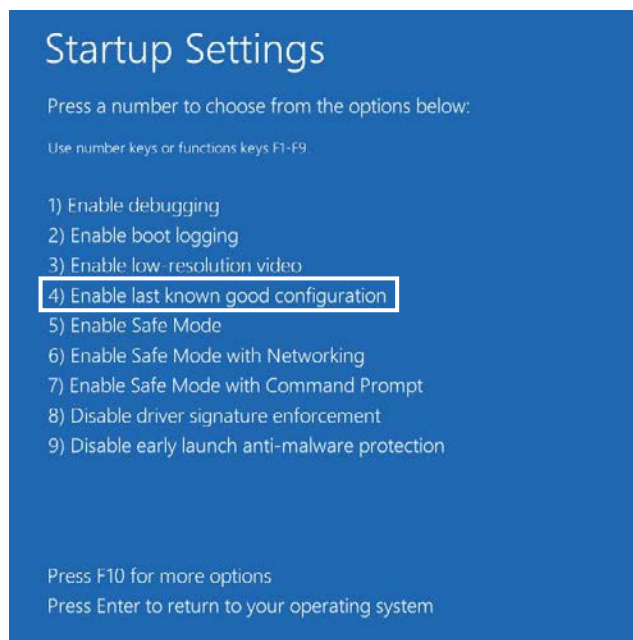

FIGURE 10-20 Enabling the last known good configuration.

Service failures

A service can have optional *FailureActions* and *FailureCommand* values in its registry key that the SCM records during the service's startup. The SCM registers with the system so that the system signals the SCM when a service process exits. When a service process terminates unexpectedly, the SCM determines which services ran in the process and takes the recovery steps specified by their failure-related registry values. Additionally, services are not only limited to requesting failure actions during crashes or unexpected service termination, since other problems, such as a memory leak, could also result in service failure.

If a service enters the *SERVICE_STOPPED* state and the error code returned to the SCM is not *ERROR_SUCCESS*, the SCM checks whether the service has the *FailureActionsOnNonCrashFailures* flag set and performs the same recovery as if the service had crashed. To use this functionality, the service must be configured via the *ChangeServiceConfig2* API or the system administrator can use the *Sc.exe* utility with the *Failureflag* parameter to set *FailureActionsOnNonCrashFailures* to 1. The default value being 0, the SCM will continue to honor the same behavior as on earlier versions of Windows for all other services.

Actions that a service can configure for the SCM include restarting the service, running a program, and rebooting the computer. Furthermore, a service can specify the failure actions that take place the first time the service process fails, the second time, and subsequent times, and it can indicate a delay period that the SCM waits before restarting the service if the service asks to be restarted. You can easily manage the recovery actions for a service using the **Recovery** tab of the service's **Properties** dialog box in the Services MMC snap-in, as shown in Figure 10-21.

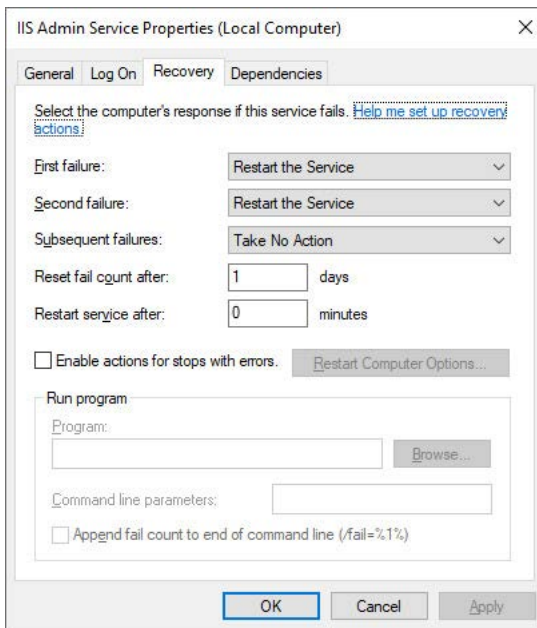

FIGURE 10-21 Service Recovery options.

Note that in case the next failure action is to reboot the computer, the SCM, after starting the service, marks the hosting process as critical by invoking the *NtSetInformationProcess* native API with the *ProcessBreakOnTermination* information class. A critical process, if terminated unexpectedly, crashes the system with the *CRITICAL_PROCESS_DIED* bugcheck (as already explained in Part 1, Chapter 2, "System architecture."

Service shutdown

When Winlogon calls the Windows *ExitWindowsEx* function, *ExitWindowsEx* sends a message to Csrss, the Windows subsystem process, to invoke Csrss's shutdown routine. Csrss loops through the active processes and notifies them that the system is shutting down. For every system process except the SCM, Csrss waits up to the number of seconds specified in milliseconds by HKCU\Control Panel\Desktop\WaitToKillTimeout (which defaults to 5 seconds) for the process to exit before moving on to the next process. When Csrss encounters the SCM process, it also notifies it that the system is shutting down but employs a timeout specific to the SCM. Csrss recognizes the SCM using the process ID Csrss saved when the SCM registered with Csrss using the *RegisterServicesProcess* function during its initialization. The SCM's timeout differs from that of other processes because Csrss knows that the SCM communicates with services that need to perform cleanup when they shut down, so an administrator might need to tune only the SCM's timeout. The SCM's timeout value in milliseconds resides in the HKLM\SYSTEM\CurrentControlSet\Control\WaitToKillServiceTimeout registry value, and it defaults to 20 seconds.

The SCM's shutdown handler is responsible for sending shutdown notifications to all the services that requested shutdown notification when they initialized with the SCM. The SCM function *ScShutdownAllServices* first queries the value of the HKLM\SYSTEM\CurrentControlSet\Control\ShutdownTimeout (by setting a default of 20 seconds in case the value does not exist). It then loops through the SCM services database. For each service, it unregisters eventual service triggers and determines whether the service desires to receive a shutdown notification, sending a shutdown command (*SERVICE_CONTROL_SHUTDOWN*) if that is the case. Note that all the notifications are sent to services in parallel by using thread pool work threads. For each service to which it sends a shutdown command, the SCM records the value of the service's wait hint, a value that a service also specifies when it registers with the SCM. The SCM keeps track of the largest wait hint it receives (in case the maximum calculated wait hint is below the Shutdown timeout specified by the *ShutdownTimeout* registry value, the shutdown timeout is considered as maximum wait hint). After sending the shutdown messages, the SCM waits either until all the services it notified of shutdown exit or until the time specified by the largest wait hint passes.

While the SCM is busy telling services to shut down and waiting for them to exit, Csrss waits for the SCM to exit. If the wait hint expires without all services exiting, the SCM exits, and Csrss continues the shutdown process. In case Csrss's wait ends without the SCM having exited (the *WaitToKillServiceTimeout* time expired), Csrss kills the SCM and continues the shutdown process. Thus, services that fail to shut down in a timely manner are killed. This logic lets the system shut down with the presence of services that never complete a shutdown as a result of flawed design, but it also means that services that require more than 5 seconds will not complete their shutdown operations.

Additionally, because the shutdown order is not deterministic, services that might depend on other services to shut down first (called shutdown dependencies) have no way to report this to the SCM and might never have the chance to clean up either.

To address these needs, Windows implements preshutdown notifications and shutdown ordering to combat the problems caused by these two scenarios. A preshutdown notification is sent to a service that has requested it via the *SetServiceStatus* API (through the *SERVICE_ACCEPT_PRESHUTDOWN* accepted control) using the same mechanism as shutdown notifications. Preshutdown notifications are sent before Wininit exits. The SCM generally waits for them to be acknowledged.

The idea behind these notifications is to flag services that might take a long time to clean up (such as database server services) and give them more time to complete their work. The SCM sends a progress query request and waits 10 seconds for a service to respond to this notification. If the service does not respond within this time, it is killed during the shutdown procedure; otherwise, it can keep running as long as it needs, as long as it continues to respond to the SCM.

Services that participate in the preshutdown can also specify a shutdown order with respect to other preshutdown services. Services that depend on other services to shut down first (for example, the Group Policy service needs to wait for Windows Update to finish) can specify their shutdown dependencies in the HKLM\SYSTEM\CurrentControlSet\Control\PreshutdownOrder registry value.

Shared service processes

Running every service in its own process instead of having services share a process whenever possible wastes system resources. However, sharing processes means that if any of the services in the process has a bug that causes the process to exit, all the services in that process terminate.

Of the Windows built-in services, some run in their own process and some share a process with other services. For example, the LSASS process contains security-related services—such as the Security Accounts Manager (SamSs) service, the Net Logon (Netlogon) service, the Encrypting File System (EFS) service, and the Crypto Next Generation (CNG) Key Isolation (KeyIso) service.

There is also a generic process named Service Host (SvcHost - %SystemRoot%\System32\Svchost.exe) to contain multiple services. Multiple instances of SvcHost run as different processes. Services that run in SvcHost processes include Telephony (TapiSrv), Remote Procedure Call (RpcSs), and Remote Access Connection Manager (RasMan). Windows implements services that run in SvcHost as DLLs and includes an ImagePath definition of the form %SystemRoot%\System32\svchost.exe -k netsvcs in the service's registry key. The service's registry key must also have a registry value named *ServiceDll* under a Parameters subkey that points to the service's DLL file.

All services that share a common SvcHost process specify the same parameter (**-k netsvcs** in the example in the preceding paragraph) so that they have a single entry in the SCM's image database. When the SCM encounters the first service that has a SvcHost ImagePath with a particular parameter during service startup, it creates a new image database entry and launches a SvcHost process with the parameter. The parameter specified with the **-k** switch is the name of the service group. The entire command line is parsed by the SCM while creating the new shared hosting process. As discussed in the "Service logon" section, in case another service in the database shares the same ImagePath value, its service SID will be added to the new hosting process's group SIDs list.

The new SvcHost process takes the service group specified in the command line and looks for a value having the same name under HKLM\SOFTWARE\Microsoft\Windows NT\CurrentVersion\Svchost. SvcHost reads the contents of the value, interpreting it as a list of service names, and notifies the SCM that it's hosting those services when SvcHost registers with the SCM.

When the SCM encounters another shared service (by checking the service type value) during service startup with an ImagePath matching an entry it already has in the image database, it doesn't launch a second process but instead just sends a start command for the service to the SvcHost it

already started for that ImagePath value. The existing SvcHost process reads the *ServiceDll* parameter in the service's registry key, enables the new service group SID in its token, and loads the DLL into its process to start the service.

Table 10-12 lists all the default service groupings on Windows and some of the services that are registered for each of them.

TABLE 10-12 Major service groupings

Service Group	Services	Notes
LocalService	Network Store Interface, Windows Diagnostic Host, Windows Time, COM+ Event System, HTTP Auto-Proxy Service, Software Protection Platform UI Notification, Thread Order Service, LLDT Discovery, SSL, FDP Host, WebClient	Services that run in the local service account and make use of the network on various ports or have no network usage at all (and hence no restrictions).
LocalServiceAndNoImpersonation	UPnP and SSDP, Smart Card, TPM, Font Cache, Function Discovery, AppID, qWAVE, Windows Connect Now, Media Center Extender, Adaptive Brightness	Services that run in the local service account and make use of the network on a fixed set of ports. Services run with a write-restricted token.
LocalServiceNetworkRestricted	DHCP, Event Logger, Windows Audio, NetBIOS, Security Center, Parental Controls, HomeGroup Provider	Services that run in the local service account and make use of the network on a fixed set of ports.
LocalServiceNoNetwork	Diagnostic Policy Engine, Base Filtering Engine, Performance Logging and Alerts, Windows Firewall, WWAN AutoConfig	Services that run in the local service account but make no use of the network at all. Services run with a write-restricted token.
LocalSystemNetworkRestricted	DWM, WDI System Host, Network Connections, Distributed Link Tracking, Windows Audio Endpoint, Wired/WLAN AutoConfig, Pnp-X, HID Access, User-Mode Driver Framework Service, Superfetch, Portable Device Enumerator, HomeGroup Listener, Tablet Input, Program Compatibility, Offline Files	Services that run in the local system account and make use of the network on a fixed set of ports.
NetworkService	Cryptographic Services, DHCP Client, Terminal Services, WorkStation, Network Access Protection, NLA, DNS Client, Telephony, Windows Event Collector, WinRM	Services that run in the network service account and make use of the network on various ports (or have no enforced network restrictions).
NetworkServiceAndNoImpersonation	KTM for DTC	Services that run in the network service account and make use of the network on a fixed set of ports. Services run with a write-restricted token.
NetworkServiceNetworkRestricted	IPSec Policy Agent	Services that run in the network service account and make use of the network on a fixed set of ports.

Svchost service splitting

As discussed in the previous section, running a service in a shared host process saves system resources but has the big drawback that a single unhandled error in a service obliges all the other services shared in the host process to be killed. To overcome this problem, Windows 10 Creators Update (RS2) has introduced the Svchost Service splitting feature.

When the SCM starts, it reads three values from the registry representing the services global commit limits (divided in: low, medium, and hard caps). These values are used by the SCM to send “low resources” messages in case the system runs under low-memory conditions. It then reads the Svchost Service split threshold value from the HKLM\SYSTEM\CurrentControlSet\Control\SvcHostSplitThresholdInKB registry value. The value contains the minimum amount of system physical memory (expressed in KB) needed to enable Svchost Service splitting (the default value is 3.5 GB on client systems and around 3.7 GB on server systems). The SCM then obtains the value of the total system physical memory using the *GlobalMemoryStatusEx* API and compares it with the threshold previously read from the registry. If the total physical memory is above the threshold, it enables Svchost service splitting (by setting an internal global variable).

Svchost service splitting, when active, modifies the behavior in which SCM starts the host Svchost process of shared services. As already discussed in the “Service start” section earlier in this chapter, the SCM does not search for an existing image record in its database if service splitting is allowed for a service. This means that, even though a service is marked as sharable, it is started using its private hosting process (and its type is changed to *SERVICE_WIN32_OWN_PROCESS*). Service splitting is allowed only if the following conditions apply:

- Svchost Service splitting is globally enabled.
- The service is not marked as critical. A service is marked as critical if its next recovery action specifies to reboot the machine (as discussed previously in the “Service failures” section).
- The service host process name is Svchost.exe.
- Service splitting is not explicitly disabled for the service through the *SvcHostSplitDisable* registry value in the service control key.

Memory manager’s technologies like Memory Compression and Combining help in saving as much of the system working set as possible. This explains one of the motivations behind the enablement of Svchost service splitting. Even though many new processes are created in the system, the memory manager assures that all the physical pages of the hosting processes remain shared and consume as little system resources as possible. Memory combining, compression, and memory sharing are explained in detail in Chapter 5 of Part 1.

EXPERIMENT: Playing with Svchost service splitting

In case you are using a Windows 10 workstation equipped with 4 GB or more of memory, when you open the Task Manager, you may notice that a lot of Svchost.exe process instances are currently executing. As explained in this section, this doesn't produce a memory waste problem, but you could be interested in disabling Svchost splitting. First, open Task Manager and count how many svchost process instances are currently running in the system. On a Windows 10 May 2019 Update (19H1) system, you should have around 80 Svchost process instances. You can easily count them by opening an administrative PowerShell window and typing the following command:

```
(get-process -Name "svchost" | measure).Count
```

On the sample system, the preceding command returned 85.

Open the Registry Editor (by typing **regedit.exe** in the Cortana search box) and navigate to the HKLM\SYSTEM\CurrentControlSet\Control key. Note the current value of the *SvcHostSplitThresholdInKB* DWORD value. To globally disable Svchost service splitting, you should modify the registry value by setting its data to 0. (You change it by double-clicking the registry value and entering 0.) After modifying the registry value, restart the system and repeat the previous step: counting the number of Svchost process instances. The system now runs with much fewer of them:

```
PS C:\> (get-process -Name "svchost" | measure).Count  
26
```

To return to the previous behavior, you should restore the previous content of the *SvcHostSplitThresholdInKB* registry value. By modifying the DWORD value, you can also fine-tune the amount of physical memory needed by Svchost splitting for correctly being enabled.

Service tags

One of the disadvantages of using service-hosting processes is that accounting for CPU time and usage, as well as for the usage of resources by a specific service is much harder because each service is sharing the memory address space, handle table, and per-process CPU accounting numbers with the other services that are part of the same service group. Although there is always a thread inside the service-hosting process that belongs to a certain service, this association might not always be easy to make. For example, the service might be using worker threads to perform its operation, or perhaps the start address and stack of the thread do not reveal the service's DLL name, making it hard to figure out what kind of work a thread might be doing and to which service it might belong.

Windows implements a service attribute called the service tag (not to be confused with the driver tag), which the SCM generates by calling *ScGenerateServiceTag* when a service is created or when the service database is generated during system boot. The attribute is simply an index identifying the service. The service tag is stored in the *SubProcessTag* field of the thread environment block (TEB) of each thread (see Chapter 3 of Part 1 for more information on the TEB) and is propagated across all threads that a main service thread creates (except threads created indirectly by thread-pool APIs).

Although the service tag is kept internal to the SCM, several Windows utilities, like Netstat.exe (a utility you can use for displaying which programs have opened which ports on the network), use undocumented APIs to query service tags and map them to service names. Another tool you can use to look at service tags is ScTagQuery from Winsider Seminars & Solutions Inc. (www.winsiderss.com/tools/sctagquery/sctagquery.htm). It can query the SCM for the mappings of every service tag and display them either systemwide or per-process. It can also show you to which services all the threads inside a service-hosting process belong. (This is conditional on those threads having a proper service tag associated with them.) This way, if you have a runaway service consuming lots of CPU time, you can identify the culprit service in case the thread start address or stack does not have an obvious service DLL associated with it.

User services

As discussed in the “Running services in alternate accounts” section, a service can be launched using the account of a local system user. A service configured in that way is always loaded using the specified user account, regardless of whether the user is currently logged on. This could represent a limitation in multiuser environments, where a service should be executed with the access token of the currently logged-on user. Furthermore, it can expose the user account at risk because malicious users can potentially inject into the service process and use its token to access resources they are not supposed to (being able also to authenticate on the network).

Available from Windows 10 Creators Update (RS2), User Services allow a service to run with the token of the currently logged-on user. User services can be run in their own process or can share a process with one or more other services running in the same logged-on user account as for standard services. They are started when a user performs an interactive logon and stopped when the user logs off. The SCM internally supports two additional type flags—*SERVICE_USER_SERVICE* (64) and *SERVICE_USERSERVICE_INSTANCE* (128)—which identify a user service template and a user service instance.

One of the states of the Winlogon finite-state machine (see Chapter 12 for details on Winlogon and the boot process) is executed when an interactive logon has been initiated. The state creates the new user’s logon session, window station, desktop, and environment; maps the *HKEY_CURRENT_USER* registry hive; and notifies the logon subscribers (LogonUI and User Manager). The User Manager service (Usermgr.dll) through RPC is able to call into the SCM for delivering the *WTS_SESSION_LOGON* session event.

The SCM processes the message through the *ScCreateUserServicesForUser* function, which calls back into the User Manager for obtaining the currently logged-on user’s token. It then queries the list of user template services from the SCM database and, for each of them, generates the new name of the user instance service.

EXPERIMENT: Witnessing user services

A kernel debugger can easily show the security attributes of a process's token. In this experiment, you need a Windows 10 machine with a kernel debugger enabled and attached to a host (a local debugger works, too). In this experiment, you choose a user service instance and analyze its hosting process's token. Open the Services tool by typing its name in the Cortana search box. The application shows standard services and also user services instances (even though it erroneously displays Local System as the user account), which can be easily identified because they have a local unique ID (LUID, generated by the User Manager) attached to their displayed names. In the example, the Connected Device User Service is displayed by the Services application as Connected Device User Service_55d01:

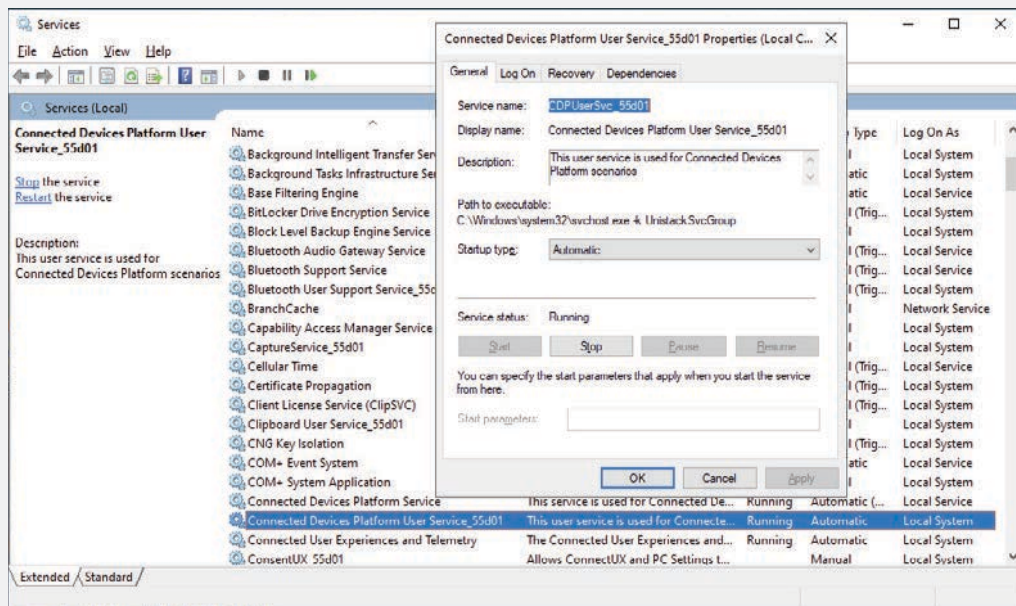

If you double-click the identified service, the tool shows the actual name of the user service instance (CDPUserSvc_55d01 in the example). If the service is hosted in a shared process, like the one chosen in the example, you should use the Registry Editor to navigate in the service root key of the user service template, which has the same name as the instance but without the LUID (the user service template name is CDPUserSvc in the example). As explained in the “Viewing privileges required by services” experiment, under the Parameters subkey, the Service DLL name is stored. The DLL name should be used in Process Explorer for finding the correct hosting process ID (or you can simply use Task Manager in the latest Windows 10 versions).

After you have found the PID of the hosting process, you should break into the kernel debugger and type the following commands (by replacing the <ServicePid> with the PID of the service's hosting process):

```
!process <ServicePid> 1
```

The debugger displays several pieces of information, including the address of the associated security token object:

```
Kd: 0> !process 0n5936 1
Searching for Process with Cid == 1730
PROCESS fffffe10646205080
  SessionId: 2  Cid: 1730  Peb: 81ebbd1000  ParentCid: 0344
  DirBase: 8fe39002  ObjectTable: fffffa387c2826340  HandleCount: 313.
  Image: svchost.exe
  VadRoot fffffe1064629c340  Vads 108  Clone 0  Private 962.  Modified 214.  Locked 0.
  DeviceMap fffffa387be1341a0
  Token                                fffffa387c2bdc060
  ElapsedTime                          00:35:29.441
  ...
<Output omitted for space reasons>
```

To show the security attributes of the token, you just need to use the !token command followed by the address of the token object (which internally is represented with a `_TOKEN` data structure) returned by the previous command. You should easily confirm that the process is hosting a user service by seeing the `WIN://ScmUserService` security attribute, as shown in the following output:

```
0: kd> !token fffffa387c2bdc060
_TOKEN 0xfffffa387c2bdc060
TS Session ID: 0x2
User: S-1-5-21-725390342-1520761410-3673083892-1001
User Groups:
  00 S-1-5-21-725390342-1520761410-3673083892-513
     Attributes - Mandatory Default Enabled
```

... <Output omitted for space reason> ...

```
OriginatingLogonSession: 3e7
PackageSid: (null)
CapabilityCount: 0      Capabilities: 0x0000000000000000
LowboxNumberEntry: 0x0000000000000000
Security Attributes:
  00 Claim Name   : WIN://SCMUserService
     Claim Flags: 0x40 - UNKNOWN
     Value Type  : CLAIM_SECURITY_ATTRIBUTE_TYPE_UINT64
     Value Count: 1
     Value[0]   : 0
  01 Claim Name   : TSA://ProcUnique
     Claim Flags: 0x41 - UNKNOWN
     Value Type  : CLAIM_SECURITY_ATTRIBUTE_TYPE_UINT64
     Value Count: 2
     Value[0]   : 102
     Value[1]   : 352550
```

Process Hacker, a system tool similar to Process Explorer and available at <https://processhacker.sourceforge.io/> is able to extract the same information.

As discussed previously, the name of a user service instance is generated by combining the original name of the service and a local unique ID (LUID) generated by the User Manager for identifying the user's interactive session (internally called context ID). The context ID for the interactive logon session is stored in the volatile HKLM\SOFTWARE\Microsoft\Windows NT\CurrentVersion\Winlogon\VolatileUserMgrKey\ <Session ID>\<User SID>\contextLuid registry value, where <Session ID> and <User SID> identify the logon session ID and the user SID. If you open the Registry Editor and navigate to this key, you will find the same context ID value as the one used for generating the user service instance name.

Figure 10-22 shows an example of a user service instance, the Clipboard User Service, which is run using the token of the currently logged-on user. The generated context ID for session 1 is 0x3a182, as shown by the User Manager volatile registry key (see the previous experiment for details). The SCM then calls *ScCreateService*, which creates a service record in the SCM database. The new service record represents a new user service instance and is saved in the registry as for normal services. The service security descriptor, all the dependent services, and the triggers information are copied from the user service template to the new user instance service.

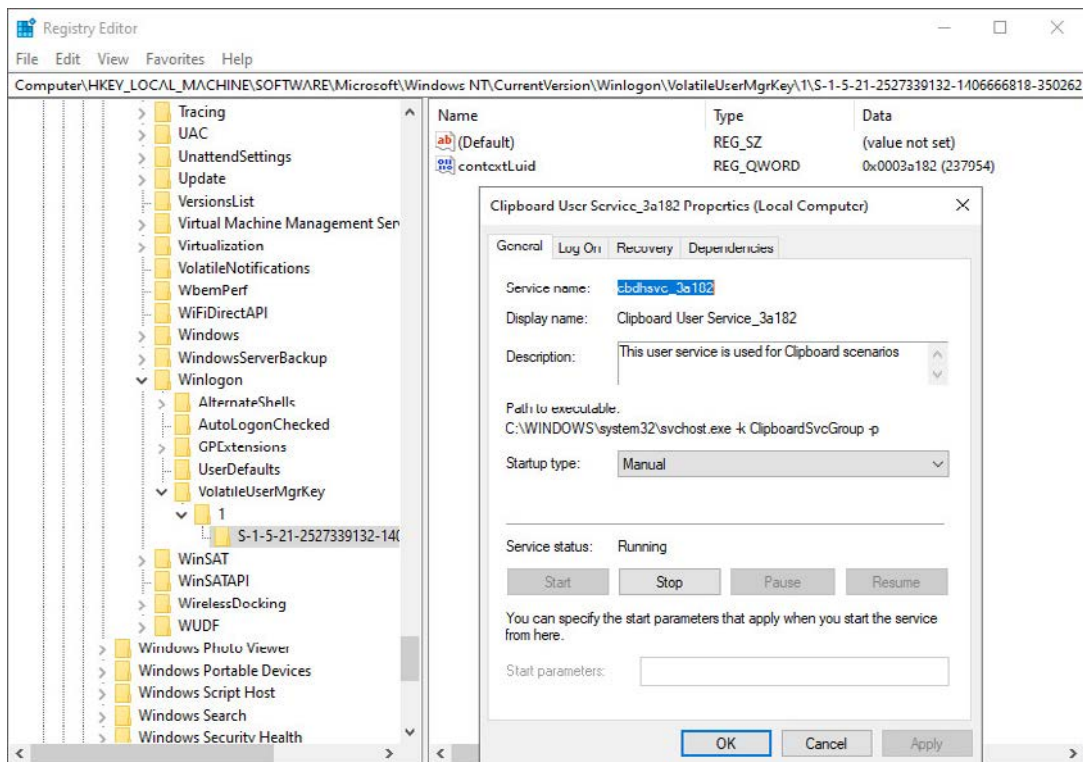

FIGURE 10-22 The Clipboard User Service instance running in the context ID 0x3a182.

The SCM registers the eventual service triggers (see the “Triggered-start services” section earlier in this chapter for details) and then starts the service (if its start type is set to `SERVICE_AUTO_START`). As discussed in the “Service logon” section, when SCM starts a process hosting a user service, it assigns the token of the current logged-on user and the `WIN://ScmUserService` security attribute used by the SCM to recognize that the process is really hosting a service. Figure 10-23 shows that, after a user has logged in to the system, both the instance and template subkeys are stored in the root services key representing the same user service. The instance subkey is deleted on user logoff and ignored if it’s still present at system startup time.

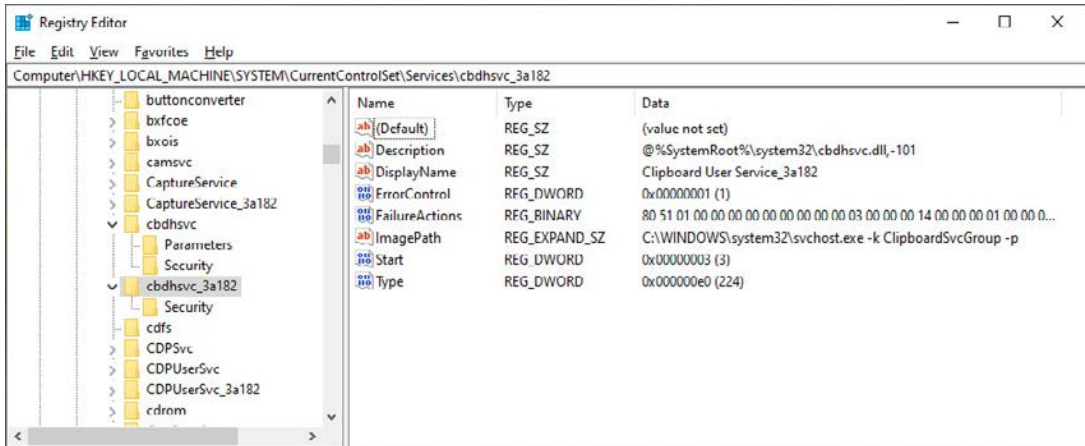

FIGURE 10-23 User service instance and template registry keys.

Packaged services

As briefly introduced in the “Service logon” section, since Windows 10 Anniversary Update (RS1), the Service Control Manager has supported packaged services. A packaged service is identified through the `SERVICE_PKG_SERVICE` (512) flag set in its service type. Packaged services have been designed mainly to support standard Win32 desktop applications (which may run with an associated service) converted to the new Modern Application Model. The Desktop App Converter is indeed able to convert a Win32 application to a Centennial app, which runs in a lightweight container, internally called Helium. More details on the Modern Application Model are available in the “Packaged application” section of Chapter 8.

When starting a packaged service, the SCM reads the package information from the registry, and, as for standard Centennial applications, calls into the AppInfo service. The latter verifies that the package information exists in the state repository and the integrity of all the application package files. It then stamps the new service’s host process token with the correct security attributes. The process is then launched in a suspended state using `CreateProcessAsUser` API (including the Package Full Name attribute) and a Helium container is created, which will apply registry redirection and Virtual File System (VFS) as for regular Centennial applications.

Protected services

Chapter 3 of Part 1 described in detail the architecture of protected processes and protected processes light (PPL). The Windows 8.1 Service Control Manager supports protected services. At the time of this writing, a service can have four levels of protection: Windows, Windows light, Antimalware light, and App. A service control program can specify the protection of a service using the *ChangeServiceConfig2* API (with the *SERVICE_CONFIG_LAUNCH_PROTECTED* information level). A service's main executable (or library in the case of shared services) must be signed properly for running as a protected service, following the same rules as for protected processes (which means that the system checks the digital signature's EKU and root certificate and generates a maximum signer level, as explained in Chapter 3 of Part 1).

A service's hosting process launched as protected guarantees a certain kind of protection with respect to other nonprotected processes. They can't acquire some access rights while trying to access a protected service's hosting process, depending on the protection level. (The mechanism is identical to standard protected processes. A classic example is a nonprotected process not being able to inject any kind of code in a protected service.)

Even processes launched under the SYSTEM account can't access a protected process. However, the SCM should be fully able to access a protected service's hosting process. So, Wininit.exe launches the SCM by specifying the maximum user-mode protection level: WinTcb Light. Figure 10-24 shows the digital signature of the SCM main executable, *services.exe*, which includes the Windows TCB Component EKU (1.3.6.1.4.1.311.10.3.23).

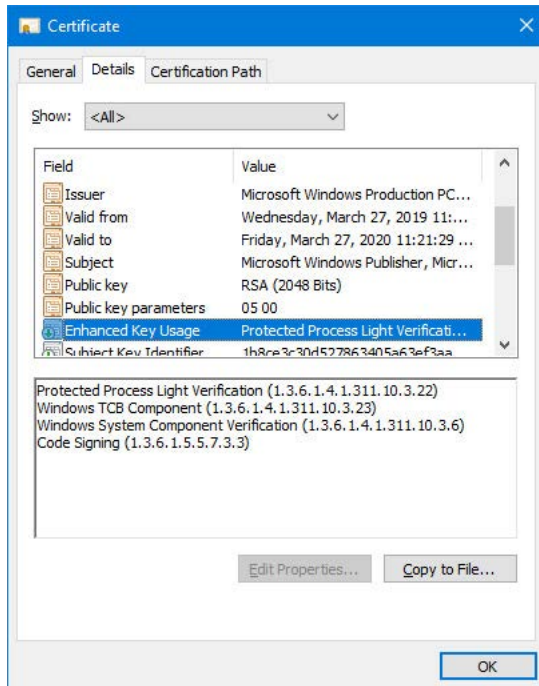

FIGURE 10-24 The Service Control Manager main executable (*services.exe*) digital certificate.

The second part of protection is brought by the Service Control Manager. While a client requests an action to be performed on a protected service, the SCM calls the *ScCheckServiceProtectedProcess* routine with the goal to check whether the caller has enough access rights to perform the requested action on the service. Table 10-13 lists the denied operations when requested by a nonprotected process on a protected service.

TABLE 10-13 List of denied operations while requested from nonprotected client

Involved API Name	Operation	Description
ChangeServiceConfig[2]	Change Service Configuration	Any change of configuration to a protected service is denied.
SetServiceObjectSecurity	Set a new security descriptor to a service	Application of a new security descriptor to a protected service is denied. (It could lower the service attack surface.)
DeleteService	Delete a Service	Nonprotected process can't delete a protected service.
ControlService	Send a control code to a service	Only service-defined control code and <i>SERVICE_CONTROL_INTERROGATE</i> are allowed for nonprotected callers. <i>SERVICE_CONTROL_STOP</i> is allowed for any protection level except for Antimalware.

The *ScCheckServiceProtectedProcess* function looks up the service record from the caller-specified service handle and, in case the service is not protected, always grants access. Otherwise, it impersonates the client process token, obtains its process protection level, and implements the following rules:

- If the request is a STOP control request and the target service is not protected at Antimalware level, grant the access (Antimalware protected services are not stoppable by non-protected processes).
- In case the TrustedInstaller service SID is present in the client's token groups or is set as the token user, the SCM grants access regarding the client's process protection.
- Otherwise, it calls *RtlTestProtectedAccess*, which performs the same checks implemented for protected processes. The access is granted only if the client process has a compatible protection level with the target service. For example, a Windows protected process can always operate on all protected service levels, while an antimalware PPL can only operate on Antimalware and app protected services.

Noteworthy is that the last check described is not executed for any client process running with the TrustedInstaller virtual service account. This is by design. When Windows Update installs an update, it should be able to start, stop, and control any kind of service without requiring itself to be signed with a strong digital signature (which could expose Windows Update to an undesired attack surface).

Task scheduling and UBPM

Various Windows components have traditionally been in charge of managing hosted or background tasks as the operating system has increased in complexity in features, from the Service Control Manager, described earlier, to the DCOM Server Launcher and the WMI Provider—all of which are also

responsible for the execution of out-of-process, hosted code. Although modern versions of Windows use the Background Broker Infrastructure to manage the majority of background tasks of modern applications (see Chapter 8 for more details), the Task Scheduler is still the main component that manages Win32 tasks. Windows implements a Unified Background Process Manager (UBPM), which handles tasks managed by the Task Scheduler.

The Task Scheduler service (*Schedule*) is implemented in the *Schedsvc.dll* library and started in a shared *Svchost* process. The Task Scheduler service maintains the tasks database and hosts UBPM, which starts and stops tasks and manages their actions and triggers. UBPM uses the services provided by the Desktop Activity Broker (DAB), the System Events Broker (SEB), and the Resource Manager for receiving notification when tasks' triggers are generated. (DAB and SEB are both hosted in the System Events Broker service, whereas Resource Manager is hosted in the Broker Infrastructure service.) Both the Task Scheduler and UBPM provide public interfaces exposed over RPC. External applications can use COM objects to attach to those interfaces and interact with regular Win32 tasks.

The Task Scheduler

The Task Scheduler implements the task store, which provides storage for each task. It also hosts the Scheduler idle service, which is able to detect when the system enters or exits the idle state, and the Event trap provider, which helps the Task Scheduler to launch a task upon a change in the machine state and provides an internal event log triggering system. The Task Scheduler also includes another component, the UBPM Proxy, which collects all the tasks' actions and triggers, converts their descriptors to a format that UBPM can understand, and sends them to UBPM.

An overview of the Task Scheduler architecture is shown in Figure 10-25. As highlighted by the picture, the Task Scheduler works deeply in collaboration with UBPM (both components run in the Task Scheduler service, which is hosted by a shared *Svchost.exe* process.) UBPM manages the task's states and receives notification from SEB, DAB, and Resource Manager through WNF states.

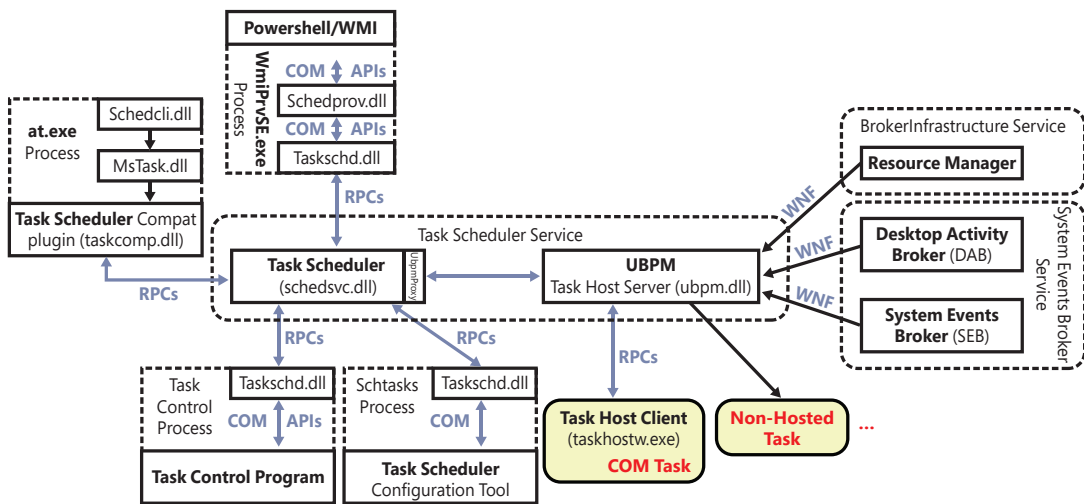

FIGURE 10-25 The Task Scheduler architecture.

The Task Scheduler has the important job of exposing the server part of the COM Task Scheduler APIs. When a Task Control program invokes one of those APIs, the Task Scheduler COM API library (Taskschd.dll) is loaded in the address space of the application by the COM engine. The library requests services on behalf of the Task Control Program to the Task Scheduler through RPC interfaces.

In a similar way, the Task Scheduler WMI provider (Schedprov.dll) implements COM classes and methods able to communicate with the Task Scheduler COM API library. Its WMI classes, properties, and events can be called from Windows PowerShell through the ScheduledTasks cmdlet (documented at <https://docs.microsoft.com/en-us/powershell/module/scheduledtasks/>). Note that the Task Scheduler includes a Compatibility plug-in, which allows legacy applications, like the AT command, to work with the Task Scheduler. In the May 2019 Update edition of Windows 10 (19H1), the AT tool has been declared deprecated, and you should instead use schtasks.exe.

Initialization

When started by the Service Control Manager, the Task Scheduler service begins its initialization procedure. It starts by registering its manifest-based ETW event provider (that has the DE7B24EA-73C8-4A09-985D-5BDADCFA9017 global unique ID). All the events generated by the Task Scheduler are consumed by UBPM. It then initializes the Credential store, which is a component used to securely access the user credentials stored by the Credential Manager and the Task store. The latter checks that all the XML task descriptors located in the Task store's secondary shadow copy (maintained for compatibility reasons and usually located in %SystemRoot%\System32\Tasks path) are in sync with the task descriptors located in the Task store cache. The Task store cache is represented by multiple registry keys, with the root being HKLM\SOFTWARE\Microsoft\Windows NT\CurrentVersion\Schedule\TaskCache.

The next step in the Task Scheduler initialization is to initialize UBPM. The Task Scheduler service uses the *UbpmlInitialize* API exported from UBPM.dll for starting the core components of UBPM. The function registers an ETW consumer of the Task Scheduler's event provider and connects to the Resource Manager. The Resource Manager is a component loaded by the Process State Manager (Psmsrv.dll, in the context of the Broker Infrastructure service), which drives resource-wise policies based on the machine state and global resource usage. Resource Manager helps UBPM to manage maintenance tasks. Those types of tasks run only in particular system states, like when the workstation CPU usage is low, when game mode is off, the user is not physically present, and so on. UBPM initialization code then retrieves the WNF state names representing the task's conditions from the System Event Broker: AC power, Idle Workstation, IP address or network available, Workstation switching to Battery power. (Those conditions are visible in the Conditions sheet of the Create Task dialog box of the Task Scheduler MMC plug-in.)

UBPM initializes its internal thread pool worker threads, obtains system power capabilities, reads a list of the maintenance and critical task actions (from the HKLM\System\CurrentControlSet\Control\Ubpml registry key and group policy settings) and subscribes to system power settings notifications (in that way UBPM knows when the system changes its power state).

The execution control returns to the Task Scheduler, which finally registers the global RPC interfaces of both itself and UBPM. Those interfaces are used by the Task Scheduler API client-side DLL (Taskschd.dll) to provide a way for client processes to interact via the Task Scheduler via the Task Scheduler COM interfaces, which are documented at <https://docs.microsoft.com/en-us/windows/win32/api/taskschd/>.

After the initialization is complete, the Task store enumerates all the tasks that are installed in the system and starts each of them. Tasks are stored in the cache in four groups: Boot, logon, plain, and Maintenance task. Each group has an associated subkey, called Index Group Tasks key, located in the Task store's root registry key (HKLM\SOFTWARE\Microsoft\Windows NT\CurrentVersion\Schedule\TaskCache, as introduced previously). Inside each Index Tasks group key is one subkey per each task, identified through a global unique identifier (GUID). The Task Scheduler enumerates the names of all the group's subkeys, and, for each of them, opens the relative Task's master key, which is located in the *Tasks* subkey of the Task store's root registry key. Figure 10-26 shows a sample boot task, which has the {0C7D8A27-9B28-49F1-979C-AD37C4D290B1} GUID. The task GUID is listed in the figure as one of the first entries in the Boot index group key. The figure also shows the master Task key, which stores binary data in the registry to entirely describe the task.

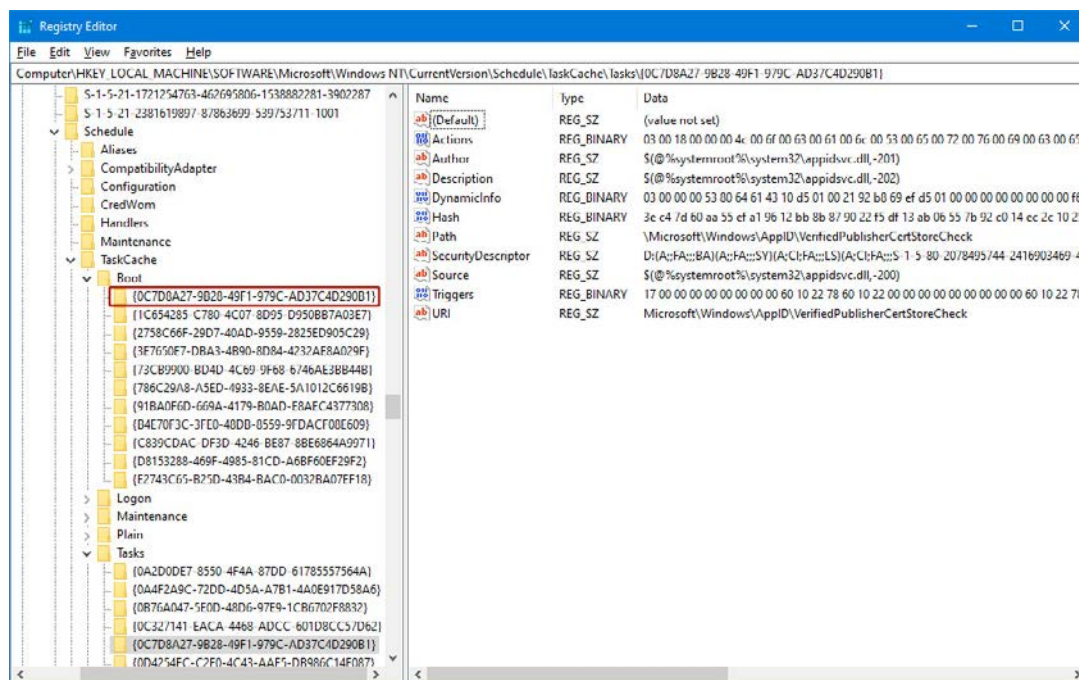

FIGURE 10-26 A boot task master key.

The task's master key contains all the information that describes the task. Two properties of the task are the most important: *Triggers*, which describe the conditions that will trigger the task, and *Actions*, which describe what happens when the task is executed. Both properties are stored in binary registry values (named "Triggers" and "Actions," as shown in Figure 10-26). The Task Scheduler first reads the hash of the entire task descriptor (stored in the *Hash* registry value); then it reads all the task's configuration data and the binary data for triggers and actions. After parsing this data, it adds each identified trigger and action descriptor to an internal list.

The Task Scheduler then recalculates the SHA256 hash of the new task descriptor (which includes all the data read from the registry) and compares it with the expected value. If the two hashes do not match, the Task Scheduler opens the XML file associated with the task contained in the store's shadow copy (the %SystemRoot%\System32\Tasks folder), parses its data and recalculates a new hash, and finally replaces the task descriptor in the registry. Indeed, tasks can be described by binary data included in the registry and also by an XML file, which adhere to a well-defined schema, documented at <https://docs.microsoft.com/en-us/windows/win32/taskschd/task-scheduler-schema>.

EXPERIMENT: Explore a task's XML descriptor

Task descriptors, as introduced in this section, are stored by the Task store in two formats: XML file and in the registry. In this experiment, you will peek at both formats. First, open the Task Scheduler applet by typing **taskschd.msc** in the Cortana search box. Expand the Task Scheduler Library node and all the subnodes until you reach the Microsoft\Windows folder. Explore each subnode and search for a task that has the **Actions** tab set to **Custom Handler**. The action type is used for describing COM-hosted tasks, which are not supported by the Task Scheduler applet. In this example, we consider the ProcessMemoryDiagnosticEvents, which can be found under the MemoryDiagnostics folder, but any task with the *Actions* set to *Custom Handler* works well:

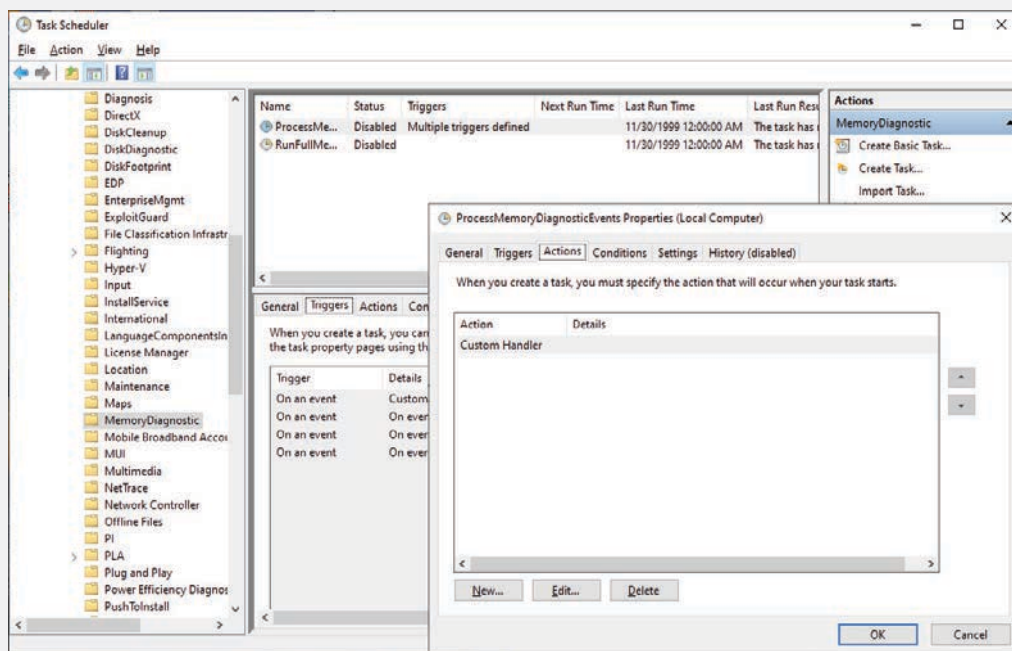

Open an administrative command prompt window (by typing **CMD** in the Cortana search box and selecting **Run As Administrator**); then type the following command (replacing the task path with the one of your choice):

```
schtasks /query /tn "Microsoft\Windows\MemoryDiagnostic\ProcessMemoryDiagnosticEvents" /xml
```

The output shows the task's XML descriptor, which includes the Task's security descriptor (used to protect the task for being opened by unauthorized identities), the task's author and description, the security principal that should run it, the task settings, and task triggers and actions:

```
<?xml version="1.0" encoding="UTF-16"?>
<Task xmlns="http://schemas.microsoft.com/windows/2004/02/mit/task">
  <RegistrationInfo>
    <Version>1.0</Version>
    <SecurityDescriptor>D:P(A;;FA;;;BA)(A;;FA;;;SY)(A;;FR;;;AU)</SecurityDescriptor>
    <Author>$(@%SystemRoot%\system32\MemoryDiagnostic.dll,-600)</Author>
    <Description>$(@%SystemRoot%\system32\MemoryDiagnostic.dll,-603)</Description>
    <URI>Microsoft\Windows\MemoryDiagnostic\ProcessMemoryDiagnosticEvents</URI>
  </RegistrationInfo>
  <Principals>
    <Principal id="LocalAdmin">
      <GroupId>S-1-5-32-544</GroupId>
      <RunLevel>HighestAvailable</RunLevel>
    </Principal>
  </Principals>
  <Settings>
    <AllowHardTerminate>>false</AllowHardTerminate>
    <DisallowStartIfOnBatteries>>true</DisallowStartIfOnBatteries>
    <StopIfGoingOnBatteries>>true</StopIfGoingOnBatteries>
    <Enabled>>false</Enabled>
    <ExecutionTimeLimit>PT2H</ExecutionTimeLimit>
    <Hidden>>true</Hidden>
    <MultipleInstancesPolicy>IgnoreNew</MultipleInstancesPolicy>
    <StartWhenAvailable>>true</StartWhenAvailable>
    <RunOnlyIfIdle>>true</RunOnlyIfIdle>
    <IdleSettings>
      <StopOnIdleEnd>>true</StopOnIdleEnd>
      <RestartOnIdle>>true</RestartOnIdle>
    </IdleSettings>
    <UseUnifiedSchedulingEngine>>true</UseUnifiedSchedulingEngine>
  </Settings>
  <Triggers>
    <EventTrigger>
      <Subscription>&lt;QueryList&gt;&lt;Query Id="0" Path="System"&gt;&lt;Select Pa
th="System"&gt;*[System[Provider[@Name='Microsoft-Windows-WER-SystemErrorReporting']
and (EventID=1000 or EventID=1001 or EventID=1006)]]&lt;/Select&gt;&lt;/Query&gt;&lt;/
QueryList&gt;</Subscription>
    </EventTrigger>
    . . . [cut for space reasons] . . .
  </Triggers>
  <Actions Context="LocalAdmin">
    <ComHandler>
      <ClassId>{8168E74A-B39F-46D8-ADCD-7BED477B80A3}</ClassId>
      <Data><![CDATA[Event]]></Data>
    </ComHandler>
  </Actions>
</Task>
```

In the case of the `ProcessMemoryDiagnosticEvents` task, there are multiple ETW triggers (which allow the task to be executed only when certain diagnostics events are generated. Indeed, the trigger descriptors include the ETW query specified in XPath format). The only registered action is a `ComHandler`, which includes just the CLSID (class ID) of the COM object representing the task. Open the Registry Editor and navigate to the `HKEY_LOCAL_MACHINE\SOFTWARE\Classes\CLSID` key. Select **Find...** from the **Edit** menu and copy and paste the CLSID located after the `ClassID` XML tag of the task descriptor (with or without the curly brackets). You should be able to find the DLL that implements the `ITaskHandler` interface representing the task, which will be hosted by the Task Host client application (`Taskhostw.exe`, described later in the “Task host client” section):

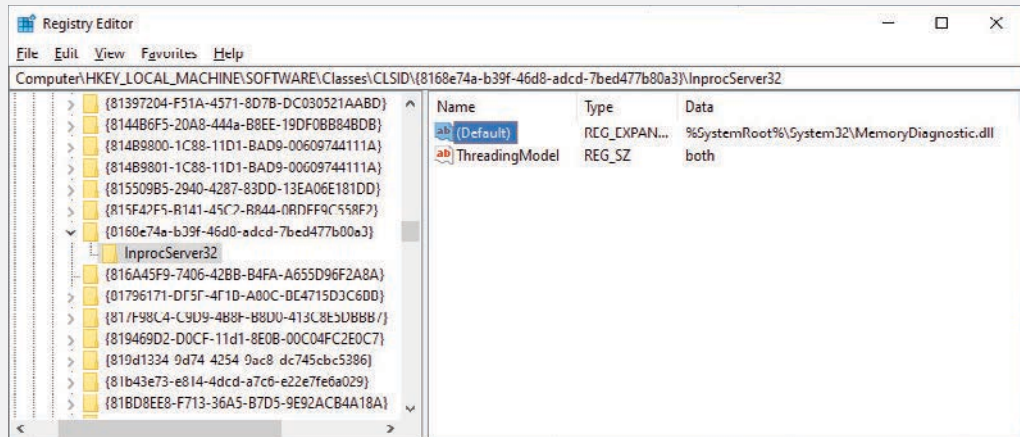

If you navigate in the `HKLM\SOFTWARE\Microsoft\Windows NT\CurrentVersion\Schedule\TaskCache\Tasks` registry key, you should also be able to find the GUID of the task descriptor stored in the Task store cache. To find it, you should search using the task’s URI. Indeed, the task’s GUID is not stored in the XML configuration file. The data belonging to the task descriptor in the registry is identical to the one stored in the XML configuration file located in the store’s shadow copy (`%systemroot%\System32\Tasks\Microsoft\Windows\MemoryDiagnostic\ProcessMemoryDiagnosticEvents`). Only the binary format in which it is stored changes.

Enabled tasks should be registered with UBPM. The Task Scheduler calls the `RegisterTask` function of the `Ubpm Proxy`, which first connects to the Credential store, for retrieving the credential used to start the task, and then processes the list of all actions and triggers (stored in an internal list), converting them in a format that UBPM can understand. Finally, it calls the `UbpmTriggerConsumerRegister` API exported from `UBPM.dll`. The task is ready to be executed when the right conditions are verified.

Unified Background Process Manager (UBPM)

Traditionally, UBPM was mainly responsible in managing tasks’ life cycles and states (start, stop, enable/disable, and so on) and to provide notification and triggers support. Windows 8.1 introduced the Broker Infrastructure and moved all the triggers and notifications management to different brokers that can

be used by both Modern and standard Win32 applications. Thus, in Windows 10, UBPM acts as a proxy for standard Win32 Tasks' triggers and translates the trigger consumers request to the correct broker. UBPM is still responsible for providing COM APIs available to applications for the following:

- Registering and unregistering a trigger consumer, as well as opening and closing a handle to one
- Generating a notification or a trigger
- Sending a command to a trigger provider

Similar to the Task Scheduler's architecture, UBPM is composed of various internal components: Task Host server and client, COM-based Task Host library, and Event Manager.

Task host server

When one of the System brokers raises an event registered by a UBPM trigger consumer (by publishing a WNF state change), the *UbpMTriggerArrived* callback function is executed. UBPM searches the internal list of a registered task's triggers (based on the WNF state name) and, when it finds the correct one, processes the task's actions. At the time of this writing, only the Launch Executable action is supported. This action supports both hosted and nonhosted executables. Nonhosted executables are regular Win32 executables that do not directly interact with UBPM; hosted executables are COM classes that directly interact with UBPM and need to be hosted by a task host client process. After a host-based executable (taskhostw.exe) is launched, it can host different tasks, depending on its associated token. (Host-based executables are very similar to shared Svchost services.)

Like SCM, UBPM supports different types of logon security tokens for task's host processes. The *UbpMTokenGetTokenForTask* function is able to create a new token based on the account information stored in the task descriptor. The security token generated by UBPM for a task can have one of the following owners: a registered user account, Virtual Service account, Network Service account, or Local Service account. Unlike SCM, UBPM fully supports Interactive tokens. UBPM uses services exposed by the User Manager (Usermgr.dll) to enumerate the currently active interactive sessions. For each session, it compares the User SID specified in the task's descriptor with the owner of the interactive session. If the two match, UBPM duplicates the token attached to the interactive session and uses it to log on the new executable. As a result, interactive tasks can run only with a standard user account. (Noninteractive tasks can run with all the account types listed previously.)

After the token has been generated, UBPM starts the task's host process. In case the task is a hosted COM task, the *UbpMFindHost* function searches inside an internal list of Taskhostw.exe (task host client) process instances. If it finds a process that runs with the same security context of the new task, it simply sends a Start Task command (which includes the COM task's name and CLSID) through the task host local RPC connection and waits for the first response. The task host client process and UBPM are connected through a static RPC channel (named ubpmtaskhostchannel) and use a connection protocol similar to the one implemented in the SCM.

If a compatible client process instance has not been found, or if the task's host process is a regular non-COM executable, UBPM builds a new environment block, parses the command line, and creates a new process in a suspended state using the *CreateProcessAsUser* API. UBPM runs each task's host process in a Job object, which allows it to quickly set the state of multiple tasks and fine-tune the resources allocated for background tasks. UBPM searches inside an internal list for Job objects containing host processes belonging to the same session ID and the same type of tasks (regular, critical, COM-based, or non-hosted). If it finds a compatible Job, it simply assigns the new process to the Job (by using the *AssignProcessToJobObject* API). Otherwise, it creates a new one and adds it to its internal list.

After the Job object has been created, the task is finally ready to be started: the initial process's thread is resumed. For COM-hosted tasks, UBPM waits for the initial contact from the task host client (performed when the client wants to open a RPC communication channel with UBPM, similar to the way in which Service control applications open a channel to the SCM) and sends the *Start Task* command. UBPM finally registers a wait callback on the task's host process, which allow it to detect when a task host's process terminates unexpectedly.

Task Host client

The Task Host client process receives commands from UBPM (Task Host Server) living in the Task Scheduler service. At initialization time, it opens the local RPC interface that was created by UBPM during its initialization and loops forever, waiting for commands to come through the channel. Four commands are currently supported, which are sent over the *TaskHostSendResponseReceiveCommand* RPC API:

- Stopping the host
- Starting a task
- Stopping a task
- Terminating a task

All task-based commands are internally implemented by a generic COM task library, and they essentially result in the creation and destruction of COM components. In particular, hosted tasks are COM objects that inherit from the *ITaskHandler* interface. The latter exposes only four required methods, which correspond to the different task's state transitions: Start, Stop, Pause, and Resume. When UBPM sends the command to start a task to its client host process, the latter (Taskhostw.exe) creates a new thread for the task. The new task worker thread uses the *CoCreateInstance* function to create an instance of the *ITaskHandler* COM object representing the task and calls its Start method. UBPM knows exactly which CLSID (class unique ID) identifies a particular task: The task's CLSID is stored by the Task store in the task's configuration and is specified at task registration time. Additionally, hosted tasks use the functions exposed by the *ITaskHandlerStatus* COM interface to notify UBPM of their current execution state. The interface uses RPCs to call *UbpmReportTaskStatus* and report the new state back to UBPM.

EXPERIMENT: Witnessing a COM-hosted task

In this experiment, you witness how the task host client process loads the COM server DLL that implements the task. For this experiment, you need the Debugging tools installed on your system. (You can find the Debugging tools as part of the Windows SDK, which is available at the <https://developer.microsoft.com/en-us/windows/downloads/windows-10-sdk/>.) You will enable the task start's debugger breakpoint by following these steps:

1. You need to set up Windbg as the default post-mortem debugger. (You can skip this step if you have connected a kernel debugger to the target system.) To do that, open an administrative command prompt and type the following commands:

```
cd "C:\Program Files (x86)\Windows Kits\10\Debuggers\x64"  
windbg.exe /I
```

Note that C:\Program Files (x86)\Windows Kits\10\Debuggers\x64 is the path of the Debugging tools, which can change depending on the debugger's version and the setup program.

2. Windbg should run and show the following message, confirming the success of the operation:

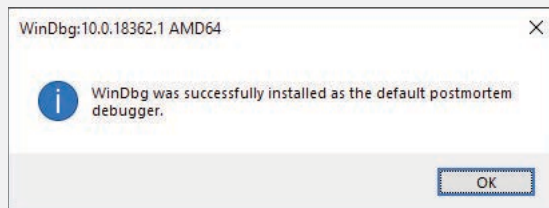

3. After you click on the **OK** button, WinDbg should close automatically.
4. Open the Task Scheduler applet (by typing **taskschd.msc** in the command prompt).
5. Note that unless you have a kernel debugger attached, you can't enable the initial task's breakpoint on noninteractive tasks; otherwise, you won't be able to interact with the debugger window, which will be spawned in another noninteractive session.
6. Looking at the various tasks (refer to the previous experiment, "Explore a task's XML descriptor" for further details), you should find an interactive COM task (named CacheTask) under the \Microsoft\Windows\Wininet path. Remember that the task's **Actions** page should show **Custom Handler**; otherwise the task is not COM task.
7. Open the Registry Editor (by typing **regedit** in the command prompt window) and navigate to the following registry key: HKLM\SOFTWARE\Microsoft\Windows NT\CurrentVersion\Schedule.
8. Right-click the Schedule key and create a new registry value by selecting **Multi-String Value** from the **New** menu.

9. Name the new registry value as *EnableDebuggerBreakForTaskStart*. To enable the initial task breakpoint, you should insert the full path of the task. In this case, the full path is `\Microsoft\Windows\Wininet\CacheTask`. In the previous experiment, the task path has been referred as the task's URI.
10. Close the Registry Editor and switch back to the Task Scheduler.
11. Right-click the CacheTask task and select **Run**.
12. If you have configured everything correctly, a new WinDbg window should appear.
13. Configure the symbols used by the debugger by selecting the Symbol File Path item from the **File** menu and by inserting a valid path to the Windows symbol server (see <https://docs.microsoft.com/en-us/windows-hardware/drivers/debugger/microsoft-public-symbols> for more details).
14. You should be able to peek at the call stack of the Taskhostw.exe process just before it was interrupted using the **k** command:

```
0:000> k
# Child-SP          RetAddr           Call Site
00 000000a7`01a7f610 00007ff6`0b0337a8 taskhostw!ComTaskMgrBase::[ComTaskMgr]::Sta
rtComTask+0x2c4
01 000000a7`01a7f960 00007ff6`0b033621 taskhostw!StartComTask+0x58
02 000000a7`01a7f9d0 00007ff6`0b033191 taskhostw!UbpmTaskHostWaitForCommands+0x2d1
3 000000a7`01a7fb00 00007ff6`0b035659 taskhostw!wWinMain+0xc1
04 000000a7`01a7fb60 00007ffa`39487bd4 taskhostw!__wmainCRTStartup+0x1c9
05 000000a7`01a7fc20 00007ffa`39aeced1 KERNEL32!BaseThreadInitThunk+0x14
06 000000a7`01a7fc50 00000000`00000000 ntdll!RtlUserThreadStart+0x21
```

15. The stack shows that the task host client has just been spawned by UBPM and has received the Start command requesting to start a task.
16. In the WinDbg console, insert the `~.` command and press Enter. Note the current executing thread ID.
17. You should now put a breakpoint on the *CoCreateInstance* COM API and resume the execution, using the following commands:

```
bp combase!CoCreateInstance
g
```
18. After the debugger breaks, again insert the `~.` command in the WinDbg console, press Enter, and note that the thread ID has completely changed.
19. This demonstrates that the task host client has created a new thread for executing the task entry point. The documented *CoCreateInstance* function is used for creating a single COM object of the class associated with a particular CLSID, specified as a parameter. Two GUIDs are interesting for this experiment: the GUID of the COM class that represents the Task and the interface ID of the interface implemented by the COM object.

- 20.** In 64-bit systems, the calling convention defines that the first four function parameters are passed through registers, so it is easy to extract those GUIDs:

```
0:004> dt combase!CLSID @rcx
{0358b920-0ac7-461f-98f4-58e32cd89148}
+0x000 Data1          : 0x358b920
+0x004 Data2          : 0xac7
+0x006 Data3          : 0x461f
+0x008 Data4          : [8] "???"
0:004> dt combase!IID @r9
{839d7762-5121-4009-9234-4f0d19394f04}
+0x000 Data1          : 0x839d7762
+0x004 Data2          : 0x5121
+0x006 Data3          : 0x4009
+0x008 Data4          : [8] "???"
```

As you can see from the preceding output, the COM server CLSID is {0358b920-0ac7-461f-98f4-58e32cd89148}. You can verify that it corresponds to the GUID of the only COM action located in the XML descriptor of the “CacheTask” task (see the previous experiment for details). The requested interface ID is “{839d7762-5121-4009-9234-4f0d19394f04}”, which correspond to the GUID of the COM task handler action interface (*ITaskHandler*).

Task Scheduler COM interfaces

As we have discussed in the previous section, a COM task should adhere to a well-defined interface, which is used by UBPM to manage the state transition of the task. While UBPM decides when to start the task and manages all of its state, all the other interfaces used to register, remove, or just manually start and stop a task are implemented by the Task Scheduler in its client-side DLL (Taskschd.dll).

ITaskService is the central interface by which clients can connect to the Task Scheduler and perform multiple operations, like enumerate registered tasks; get an instance of the Task store (represented by the *ITaskFolder* COM interface); and enable, disable, delete, or register a task and all of its associated triggers and actions (by using the *ITaskDefinition* COM interface). When a client application invokes for the first time a Task Scheduler APIs through COM, the system loads the Task Scheduler client-side DLL (Taskschd.dll) into the client process’s address space (as dictated by the COM contract: Task Scheduler COM objects live in an in-proc COM server). The COM APIs are implemented by routing requests through RPC calls into the Task Scheduler service, which processes each request and forwards it to UBPM if needed. The Task Scheduler COM architecture allows users to interact with it via scripting languages like PowerShell (through the ScheduledTasks cmdlet) or VBScript.

Windows Management Instrumentation

Windows Management Instrumentation (WMI) is an implementation of Web-Based Enterprise Management (WBEM), a standard that the Distributed Management Task Force (DMTF—an industry consortium) defines. The WBEM standard encompasses the design of an extensible enterprise

data-collection and data-management facility that has the flexibility and extensibility required to manage local and remote systems that comprise arbitrary components.

WMI architecture

WMI consists of four main components, as shown in Figure 10-27: management applications, WMI infrastructure, providers, and managed objects. Management applications are Windows applications that access and display or process data about managed objects. A simple example of a management application is a performance tool replacement that relies on WMI rather than the Performance API to obtain performance information. A more complex example is an enterprise-management tool that lets administrators perform automated inventories of the software and hardware configuration of every computer in their enterprise.

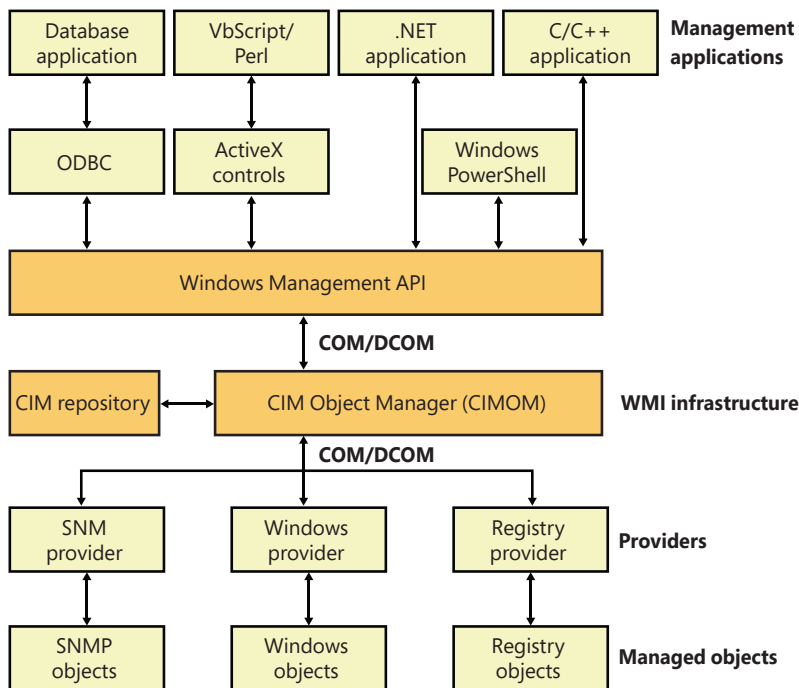

FIGURE 10-27 WMI architecture.

Developers typically must target management applications to collect data from and manage specific objects. An object might represent one component, such as a network adapter device, or a collection of components, such as a computer. (The computer object might contain the network adapter object.) Providers need to define and export the representation of the objects that management applications are interested in. For example, the vendor of a network adapter might want to add adapter-specific properties to the network adapter WMI support that Windows includes, querying and setting the adapter's state and behavior as the management applications direct. In some cases (for example, for device drivers), Microsoft supplies a provider that has its own API to help developers leverage the provider's implementation for their own managed objects with minimal coding effort.

The WMI infrastructure, the heart of which is the Common Information Model (CIM) Object Manager (CIMOM), is the glue that binds management applications and providers. (CIM is described later in this chapter.) The infrastructure also serves as the object-class store and, in many cases, as the storage manager for persistent object properties. WMI implements the store, or repository, as an on-disk database named the CIMOM Object Repository. As part of its infrastructure, WMI supports several APIs through which management applications access object data and providers supply data and class definitions.

Windows programs and scripts (such as Windows PowerShell) use the WMI COM API, the primary management API, to directly interact with WMI. Other APIs layer on top of the COM API and include an Open Database Connectivity (ODBC) adapter for the Microsoft Access database application. A database developer uses the WMI ODBC adapter to embed references to object data in the developer's database. Then the developer can easily generate reports with database queries that contain WMI-based data. WMI ActiveX controls support another layered API. Web developers use the ActiveX controls to construct web-based interfaces to WMI data. Another management API is the WMI scripting API, for use in script-based applications (like Visual Basic Scripting Edition). WMI scripting support exists for all Microsoft programming language technologies.

Because WMI COM interfaces are for management applications, they constitute the primary API for providers. However, unlike management applications, which are COM clients, providers are COM or Distributed COM (DCOM) servers (that is, the providers implement COM objects that WMI interacts with). Possible embodiments of a WMI provider include DLLs that load into a WMI's manager process or stand-alone Windows applications or Windows services. Microsoft includes a number of built-in providers that present data from well-known sources, such as the Performance API, the registry, the Event Manager, Active Directory, SNMP, and modern device drivers. The WMI SDK lets developers develop third-party WMI providers.

WMI providers

At the core of WBEM is the DMTF-designed CIM specification. The CIM specifies how management systems represent, from a systems management perspective, anything from a computer to an application or device on a computer. Provider developers use the CIM to represent the components that make up the parts of an application for which the developers want to enable management. Developers use the Managed Object Format (MOF) language to implement a CIM representation.

In addition to defining classes that represent objects, a provider must interface WMI to the objects. WMI classifies providers according to the interface features the providers supply. Table 10-14 lists WMI provider classifications. Note that a provider can implement one or more features; therefore, a provider can be, for example, both a class and an event provider. To clarify the feature definitions in Table 10-14, let's look at a provider that implements several of those features. The Event Log provider supports several objects, including an Event Log Computer, an Event Log Record, and an Event Log File. The Event Log is an Instance provider because it can define multiple instances for several of its classes. One class for which the Event Log provider defines multiple instances is the Event Log File class (*Win32_NTEventlogFile*); the Event Log provider defines an instance of this class for each of the system's event logs (that is, System Event Log, Application Event Log, and Security Event Log).

TABLE 10-14 Provider classifications

Classification	Description
Class	Can supply, modify, delete, and enumerate a provider-specific class. It can also support query processing. Active Directory is a rare example of a service that is a class provider.
Instance	Can supply, modify, delete, and enumerate instances of system and provider-specific classes. An instance represents a managed object. It can also support query processing.
Property	Can supply and modify individual object property values.
Method	Supplies methods for a provider-specific class.
Event	Generates event notifications.
Event consumer	Maps a physical consumer to a logical consumer to support event notification.

The Event Log provider defines the instance data and lets management applications enumerate the records. To let management applications use WMI to back up and restore the Event Log files, the Event Log provider implements backup and restore methods for Event Log File objects. Doing so makes the Event Log provider a Method provider. Finally, a management application can register to receive notification whenever a new record writes to one of the Event Logs. Thus, the Event Log provider serves as an Event provider when it uses WMI event notification to tell WMI that Event Log records have arrived.

The Common Information Model and the Managed Object Format Language

The CIM follows in the steps of object-oriented languages such as C++ and C#, in which a modeler designs representations as classes. Working with classes lets developers use the powerful modeling techniques of inheritance and composition. Subclasses can inherit the attributes of a parent class, and they can add their own characteristics and override the characteristics they inherit from the parent class. A class that inherits properties from another class derives from that class. Classes also compose: a developer can build a class that includes other classes. CIM classes consist of properties and methods. Properties describe the configuration and state of a WMI-managed resource, and methods are executable functions that perform actions on the WMI-managed resource.

The DMTF provides multiple classes as part of the WBEM standard. These classes are CIM's basic language and represent objects that apply to all areas of management. The classes are part of the CIM core model. An example of a core class is *CIM_ManagedSystemElement*. This class contains a few basic properties that identify physical components such as hardware devices and logical components such as processes and files. The properties include a caption, description, installation date, and status. Thus, the *CIM_LogicalElement* and *CIM_PhysicalElement* classes inherit the attributes of the *CIM_ManagedSystemElement* class. These two classes are also part of the CIM core model. The WBEM standard calls these classes abstract classes because they exist solely as classes that other classes inherit (that is, no object instances of an abstract class exist). You can therefore think of abstract classes as templates that define properties for use in other classes.

A second category of classes represents objects that are specific to management areas but independent of a particular implementation. These classes constitute the common model and are considered an extension of the core model. An example of a common-model class is the *CIM_FileSystem* class,

which inherits the attributes of `CIM_LogicalElement`. Because virtually every operating system—including Windows, Linux, and other varieties of UNIX—rely on file system–based structured storage, the `CIM_FileSystem` class is an appropriate constituent of the common model.

The final class category, the extended model, comprises technology-specific additions to the common model. Windows defines a large set of these classes to represent objects specific to the Windows environment. Because all operating systems store data in files, the CIM model includes the `CIM_LogicalFile` class. The `CIM_DataFile` class inherits the `CIM_LogicalFile` class, and Windows adds the `Win32_PageFile` and `Win32_ShortcutFile` file classes for those Windows file types.

Windows includes different WMI management applications that allow an administrator to interact with WMI namespaces and classes. The WMI command-line utility (`WMIC.exe`) and Windows PowerShell are able to connect to WMI, execute queries, and invoke WMI class object methods. Figure 10-28 shows a PowerShell window extracting information of the `Win32_NTEventlogFile` class, part of the Event Log provider. This class makes extensive use of inheritance and derives from `CIM_DataFile`. Event Log files are data files that have additional Event Log–specific attributes such as a log file name (`LogfileName`) and a count of the number of records that the file contains (`NumberOfRecords`). The `Win32_NTEventlogFile` is based on several levels of inheritance, in which `CIM_DataFile` derives from `CIM_LogicalFile`, which derives from `CIM_LogicalElement`, and `CIM_LogicalElement` derives from `CIM_ManagedSystemElement`.

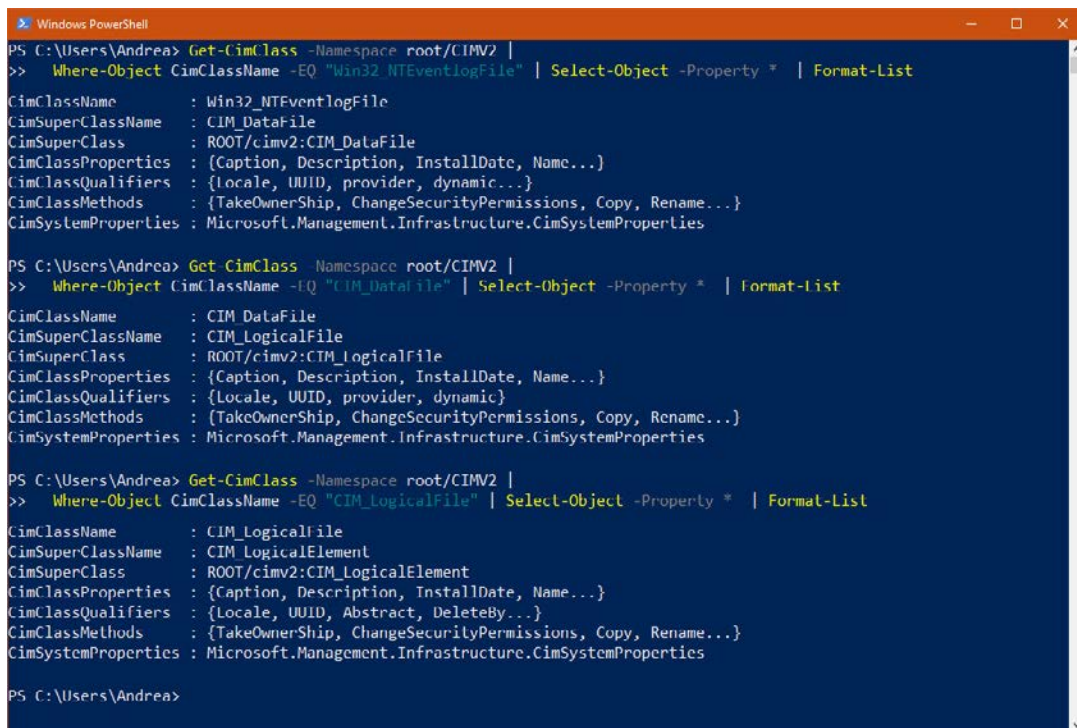

```
PS C:\Users\Andrea> Get-CimClass -Namespace root/CIMV2 |
>> Where-Object CimClassName -EQ "Win32_NTEventlogFile" | Select-Object -Property * | Format-List
CimClassName       : Win32_NTEventlogFile
CimSuperClassName  : CIM_DataFile
CimSuperClass      : ROOT/cimv2:CIM_DataFile
CimClassProperties : {Caption, Description, InstallDate, Name...}
CimClassQualifiers : {Locale, UUID, provider, dynamic...}
CimClassMethods    : {TakeOwnership, ChangeSecurityPermissions, Copy, Rename...}
CimSystemProperties : Microsoft.Management.Infrastructure.CimSystemProperties

PS C:\Users\Andrea> Get-CimClass -Namespace root/CIMV2 |
>> Where-Object CimClassName -EQ "CIM_DataFile" | Select-Object -Property * | Format-List
CimClassName       : CIM_DataFile
CimSuperClassName  : CIM_LogicalFile
CimSuperClass      : ROOT/cimv2:CIM_LogicalFile
CimClassProperties : {Caption, Description, InstallDate, Name...}
CimClassQualifiers : {Locale, UUID, provider, dynamic}
CimClassMethods    : {TakeOwnership, ChangeSecurityPermissions, Copy, Rename...}
CimSystemProperties : Microsoft.Management.Infrastructure.CimSystemProperties

PS C:\Users\Andrea> Get-CimClass -Namespace root/CIMV2 |
>> Where-Object CimClassName -EQ "CIM_LogicalFile" | Select-Object -Property * | Format-List
CimClassName       : CIM_LogicalFile
CimSuperClassName  : CIM_LogicalElement
CimSuperClass      : ROOT/cimv2:CIM_LogicalElement
CimClassProperties : {Caption, Description, InstallDate, Name...}
CimClassQualifiers : {Locale, UUID, Abstract, DeleteBy...}
CimClassMethods    : {TakeOwnership, ChangeSecurityPermissions, Copy, Rename...}
CimSystemProperties : Microsoft.Management.Infrastructure.CimSystemProperties

PS C:\Users\Andrea>
```

FIGURE 10-28 Windows PowerShell extracting information from the `Win32_NTEventlogFile` class.

As stated earlier, WMI provider developers write their classes in the MOF language. The following output shows the definition of the Event Log provider's *Win32_NTEventlogFile*, which has been queried in Figure 10-28:

```
[dynamic: ToInstance, provider("MS_NT_EVENTLOG_PROVIDER"): ToInstance, SupportsUpdate,
Locale(1033): ToInstance, UUID("{8502C57B-5FBB-11D2-AAC1-006008C78BC7}"): ToInstance]
class Win32_NTEventlogFile : CIM_DataFile
{
    [Fixed: ToSubClass, read: ToSubClass] string LogFileName;
    [read: ToSubClass, write: ToSubClass] uint32 MaxFileSize;
    [read: ToSubClass] uint32 NumberOfRecords;
    [read: ToSubClass, volatile: ToSubClass, ValueMap{"0", "1..365", "4294967295"}:
    ToSubClass] string OverWritePolicy;
    [read: ToSubClass, write: ToSubClass, Range("0-365 | 4294967295"): ToSubClass]
    uint32 OverwriteOutDated;
    [read: ToSubClass] string Sources[];
    [ValueMap{"0", "8", "21", ".."}: ToSubClass, implemented, Privileges{
    "SeSecurityPrivilege", "SeBackupPrivilege"}: ToSubClass]
    uint32 ClearEventlog([in] string ArchiveFileName);
    [ValueMap{"0", "8", "21", "183", ".."}: ToSubClass, implemented, Privileges{
    "SeSecurityPrivilege", "SeBackupPrivilege"}: ToSubClass]
    uint32 BackupEventlog([in] string ArchiveFileName);
};
```

One term worth reviewing is *dynamic*, which is a descriptive designator for the *Win32_NTEventlogFile* class that the MOF file in the preceding output shows. *Dynamic* means that the WMI infrastructure asks the WMI provider for the values of properties associated with an object of that class whenever a management application queries the object's properties. A static class is one in the WMI repository; the WMI infrastructure refers to the repository to obtain the values instead of asking a provider for the values. Because updating the repository is a relatively expensive operation, dynamic providers are more efficient for objects that have properties that change frequently.

EXPERIMENT: Viewing the MOF definitions of WMI classes

You can view the MOF definition for any WMI class by using the Windows Management Instrumentation Tester tool (*WbemTest*) that comes with Windows. In this experiment, we look at the MOF definition for the *Win32_NTEventLogFile* class:

1. Type **Wbemtest** in the Cortana search box and press Enter. The Windows Management Instrumentation Tester should open.
2. Click the **Connect** button, change the Namespace to `root\cimv2`, and connect. The tool should enable all the command buttons, as shown in the following figure:

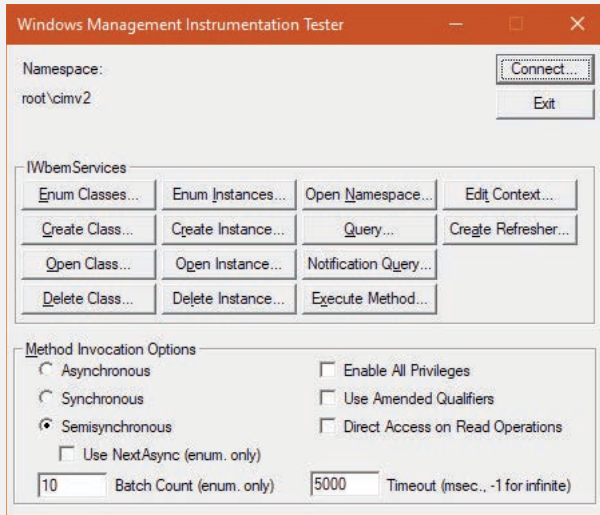

3. Click the **Enum Classes** button, select the **Recursive** option button, and then click **OK**.
4. Find *Win32_NTEventLogFile* in the list of classes, and then double-click it to see its class properties.
5. Click the **Show MOF** button to open a window that displays the MOF text.

After constructing classes in MOF, WMI developers can supply the class definitions to WMI in several ways. WDM driver developers compile a MOF file into a binary MOF (BMF) file—a more compact binary representation than an MOF file—and can choose to dynamically give the BMF files to the WDM infrastructure or to statically include it in their binary. Another way is for the provider to compile the MOF and use WMI COM APIs to give the definitions to the WMI infrastructure. Finally, a provider can use the MOF Compiler (Mofcomp.exe) tool to give the WMI infrastructure a classes-compiled representation directly.



Note Previous editions of Windows (until Windows 7) provided a graphical tool, called WMI CIM Studio, shipped with the WMI Administrative Tool. The tool was able to graphically show WMI namespaces, classes, properties, and methods. Nowadays, the tool is not supported or available for download because it was superseded by the WMI capacities of Windows PowerShell. PowerShell is a scripting language that does not run with a GUI. Some third-party tools present a similar interface of CIM Studio. One of them is WMI Explorer, which is downloadable from <https://github.com/vinaypamnani/wmie2/releases>.

The Common Information Model (CIM) repository is stored in the %SystemRoot%\System32\wbem\Repository path and includes the following:

- **Index.btr** Binary-tree (btree) index file
- **MappingX.map** Transaction control files (X is a number starting from 1)
- **Objects.data** CIM repository where managed resource definitions are stored

The WMI namespace

Classes define objects, which are provided by a WMI provider. Objects are class instances on a system. WMI uses a namespace that contains several subnamespaces that WMI arranges hierarchically to organize objects. A management application must connect to a namespace before the application can access objects within the namespace.

WMI names the namespace root directory ROOT. All WMI installations have four predefined namespaces that reside beneath root: CIMV2, Default, Security, and WMI. Some of these namespaces have other namespaces within them. For example, CIMV2 includes the Applications and ms_409 namespaces as subnamespaces. Providers sometimes define their own namespaces; you can see the WMI namespace (which the Windows device driver WMI provider defines) beneath ROOT in Windows.

Unlike a file system namespace, which comprises a hierarchy of directories and files, a WMI namespace is only one level deep. Instead of using names as a file system does, WMI uses object properties that it defines as keys to identify the objects. Management applications specify class names with key names to locate specific objects within a namespace. Thus, each instance of a class must be uniquely identifiable by its key values. For example, the Event Log provider uses the *Win32_NTLogEvent* class to represent records in an Event Log. This class has two keys: *LogFile*, a string; and *RecordNumber*, an unsigned integer. A management application that queries WMI for instances of Event Log records obtains them from the provider key pairs that identify records. The application refers to a record using the syntax that you see in this sample object path name:

```
\\ANDREA-LAPTOP\root\CIMV2:Win32_NTLogEvent.Logfile="Application",  
RecordNumber="1"
```

The first component in the name (\\ANDREA-LAPTOP) identifies the computer on which the object is located, and the second component (\root\CIMV2) is the namespace in which the object resides. The class name follows the colon, and key names and their associated values follow the period. A comma separates the key values.

WMI provides interfaces that let applications enumerate all the objects in a particular class or to make queries that return instances of a class that match a query criterion.

Class association

Many object types are related to one another in some way. For example, a computer object has a processor, software, an operating system, active processes, and so on. WMI lets providers construct an association class to represent a logical connection between two different classes. Association classes

associate one class with another, so the classes have only two properties: a class name and the Ref modifier. The following output shows an association in which the Event Log provider's MOF file associates the *Win32_NTLogEvent* class with the *Win32_ComputerSystem* class. Given an object, a management application can query associated objects. In this way, a provider defines a hierarchy of objects.

```
[dynamic: ToInstance, provider("MS_NT_EVENTLOG_PROVIDER"): ToInstance, EnumPrivileges{"SeSecurityPrivilege"}: ToSubClass, Privileges{"SeSecurityPrivilege"}: ToSubClass, Locale(1033): ToInstance, UUID("{8502C57F-5FBB-11D2-AAC1-006008C78BC7}"): ToInstance, Association: DisableOverride ToInstance ToSubClass]
class Win32_NTLogEventComputer
{
    [key, read: ToSubClass] Win32_ComputerSystem ref Computer;
    [key, read: ToSubClass] Win32_NTLogEvent ref Record;
};
```

Figure 10-29 shows a PowerShell window displaying the first *Win32_NTLogEventComputer* class instance located in the CIMV2 namespace. From the aggregated class instance, a user can query the associated *Win32_ComputerSystem* object instance WIN-46E4EFTBP6Q, which generated the event with record number 1031 in the Application log file.

```
Administrator: Windows PowerShell
PS C:\Users\Administrator> $query = "SELECT * FROM Win32_NTLogEventComputer"
PS C:\Users\Administrator> $NTLogEvents = Get-WmiObject -Query $query
PS C:\Users\Administrator> $NTLogEvents[0] | Select-Object Computer, Record

Computer                                Record
-----                                -
Win32_ComputerSystem.Name="WIN-46E4EFTBP6Q" Win32_NTLogEvent.Logfile="Application",RecordNumber=1031

PS C:\Users\Administrator> $query = "Select * FROM Win32_NTLogEvent WHERE Logfile='Application' AND RecordNumber=1031"
PS C:\Users\Administrator> Get-WmiObject -Query $query

Category           : 0
CategoryString     : 
EventCode          : 1008
EventIdentifier    : 1008
TypeEvent          : 
InsertionStrings   : {WDSTFTP, C:\WINDOWS\system32\wdstftp.dll, 2}
Logfile            : Application
Message            : The Open procedure for service "WDSTFTP" in DLL "C:\WINDOWS\system32\wdstftp.dll" failed with error
                    : code The system cannot find the file specified.. Performance data for this service will not be
                    : available.
RecordNumber       : 1031
SourceName         : Microsoft-Windows-Perflib
TimeGenerated      : 20200313195847.393885-000
TimeWritten        : 20200313195847.393885-000
Type               : Warning
UserName           : 

PS C:\Users\Administrator> $query = "Select * FROM Win32_ComputerSystem WHERE Name='WIN-46E4EFTBP6Q'"
PS C:\Users\Administrator> Get-WmiObject -Query $query

Domain              : WORKGROUP
Manufacturer        : Microsoft Corporation
Model               : Virtual Machine
Name                 : WIN-46E4EFTBP6Q
PrimaryOwnerName    : Windows User
TotalPhysicalMemory : 4290617344
```

FIGURE 10-29 The *Win32_NTLogEventComputer* association class.

EXPERIMENT: Using WMI scripts to manage systems

A powerful aspect of WMI is its support for scripting languages. Microsoft has generated hundreds of scripts that perform common administrative tasks for managing user accounts, files, the registry, processes, and hardware devices. The Microsoft TechNet Scripting Center website serves as the central location for Microsoft scripts. Using a script from the scripting center is as easy as copying its text from your Internet browser, storing it in a file with a .vbs extension, and running it with the command `cscript script.vbs`, where `script` is the name you gave the script. `Cscript` is the command-line interface to Windows Script Host (WSH).

Here's a sample TechNet script that registers to receive events when `Win32_Process` object instances are created, which occur whenever a process starts and prints a line with the name of the process that the object represents:

```
strComputer = "."
Set objWMIService = GetObject("winmgmts:" _
    & "{impersonationLevel=impersonate}!\\" & strComputer & "\root\cimv2")
Set colMonitoredProcesses = objWMIService. _
    ExecNotificationQuery("SELECT * FROM __InstanceCreationEvent " _
        & " WITHIN 1 WHERE TargetInstance ISA 'Win32_Process'")
i = 0
Do While i = 0
    Set objLatestProcess = colMonitoredProcesses.NextEvent
    Wscript.Echo objLatestProcess.TargetInstance.Name
Loop
```

The line that invokes `ExecNotificationQuery` does so with a parameter that includes a `select` statement, which highlights WMI's support for a read-only subset of the ANSI standard Structured Query Language (SQL), known as WQL, to provide a flexible way for WMI consumers to specify the information they want to extract from WMI providers. Running the sample script with `Cscript` and then starting Notepad results in the following output:

```
C:\>cscript monproc.vbs
Microsoft (R) Windows Script Host Version 5.812
Copyright (C) Microsoft Corporation. All rights reserved.
```

```
NOTEPAD.EXE
```

PowerShell supports the same functionality through the **Register-WmiEvent** and **Get-Event** commands:

```
PS C:\> Register-WmiEvent -Query "SELECT * FROM __InstanceCreationEvent WITHIN 1 WHERE
TargetInstance ISA 'Win32_Process'" -SourceIdentifier "TestWmiRegistration"
```

```
PS C:\> (Get-Event)[0].SourceEventArgs.NewEvent.TargetInstance | Select-Object -Property
ProcessId, ExecutablePath
```

```
ProcessId ExecutablePath
-----
76016 C:\WINDOWS\system32\notepad.exe
```

```
PS C:\> Unregister-Event -SourceIdentifier "TestWmiRegistration"
```

WMI implementation

The WMI service runs in a shared Svchost process that executes in the local system account. It loads providers into the WmiPrvSE.exe provider-hosting process, which launches as a child of the DCOM Launcher (RPC service) process. WMI executes Wmiprvse in the local system, local service, or network service account, depending on the value of the HostingModel property of the WMI Win32Provider object instance that represents the provider implementation. A Wmiprvse process exits after the provider is removed from the cache, one minute following the last provider request it receives.

EXPERIMENT: Viewing Wmiprvse creation

You can see WmiPrvSE being created by running Process Explorer and executing Wmic. A WmiPrvSE process will appear beneath the Svchost process that hosts the DCOM Launcher service. If Process Explorer job highlighting is enabled, it will appear with the job highlight color because, to prevent a runaway provider from consuming all virtual memory resources on a system, Wmiprvse executes in a job object that limits the number of child processes it can create and the amount of virtual memory each process and all the processes of the job can allocate. (See Chapter 5 for more information on job objects.)

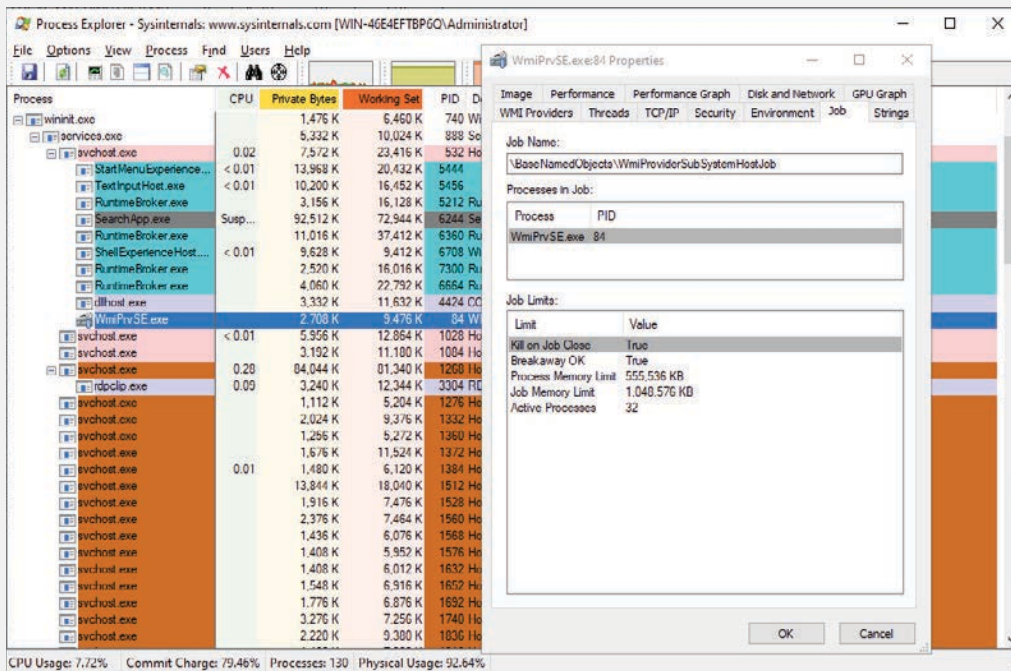

Most WMI components reside by default in %SystemRoot%\System32 and %SystemRoot%\System32\Wbem, including Windows MOF files, built-in provider DLLs, and management application WMI DLLs. Look in the %SystemRoot%\System32\Wbem directory, and you'll find Ntevt.mof, the Event Log provider MOF file. You'll also find Ntevt.dll, the Event Log provider's DLL, which the WMI service uses.

Providers are generally implemented as dynamic link libraries (DLLs) exposing COM servers that implement a specified set of interfaces (*WbemServices* is the central one. Generally, a single provider is implemented as a single COM server). WMI includes many built-in providers for the Windows family of operating systems. The built-in providers, also known as standard providers, supply data and management functions from well-known operating system sources such as the Win32 subsystem, event logs, performance counters, and registry. Table 10-15 lists several of the standard WMI providers included with Windows.

TABLE 10-15 Standard WMI providers included with Windows

Provider	Binary	Namespace	Description
Active Directory provider	dsprov.dll	root\directory\ldap	Maps Active Directory objects to WMI
Event Log provider	ntevt.dll	root\cimv2	Manages Windows event logs—for example, read, backup, clear, copy, delete, monitor, rename, compress, uncompress, and change event log settings
Performance Counter provider	wbemperf.dll	root\cimv2	Provides access to raw performance data
Registry provider	stdprov.dll	root\default	Reads, writes, enumerates, monitors, creates, and deletes registry keys and values
Virtualization provider	vmmsprox.dll	root\virtualization\v2	Provides access to virtualization services implemented in vmms.exe, like managing virtual machines in the host system and retrieving information of the host system peripherals from a guest VM
WDM provider	wmiprov.dll	root\wmi	Provides access to information on WDM device drivers
Win32 provider	cimwin32.dll	root\cimv2	Provides information about the computer, disks, peripheral devices, files, folders, file systems, networking components, operating system, printers, processes, security, services, shares, SAM users and groups, and more
Windows Installer provider	msiprov.dll	root\cimv2	Provides access to information about installed software

Ntevt.dll, the Event Log provider DLL, is a COM server, registered in the HKLM\Software\Classes\CLSID registry key with the {F55C5B4C-517D-11d1-AB57-00C04FD9159E} CLSID. (You can find it in the MOF descriptor.) Directories beneath %SystemRoot%\System32\Wbem store the repository, log files, and third-party MOF files. WMI implements the repository—named the CIMOM object repository—using a proprietary version of the Microsoft JET database engine. The database file, by default, resides in SystemRoot%\System32\Wbem\Repository\.

WMI honors numerous registry settings that the service's HKLM\SOFTWARE\Microsoft\WBEM\CIMOM registry key stores, such as thresholds and maximum values for certain parameters.

Device drivers use special interfaces to provide data to and accept commands—called the WMI System Control commands—from WMI. These interfaces are part of the WDM, which is explained in Chapter 6 of Part 1. Because the interfaces are cross-platform, they fall under the \root\WMI namespace.

WMI security

WMI implements security at the namespace level. If a management application successfully connects to a namespace, the application can view and access the properties of all the objects in that namespace. An administrator can use the WMI Control application to control which users can access a namespace. Internally, this security model is implemented by using ACLs and Security Descriptors, part of the standard Windows security model that implements Access Checks. (See Chapter 7 of Part 1 for more information on access checks.)

To start the WMI Control application, open the Control Panel by typing **Computer Management** in the Cortana search box. Next, open the Services And Applications node. Right-click WMI Control and select **Properties** to launch the WMI Control Properties dialog box, as shown in Figure 10-30. To configure security for namespaces, click the **Security** tab, select the namespace, and click **Security**. The other tabs in the WMI Control Properties dialog box let you modify the performance and backup settings that the registry stores.

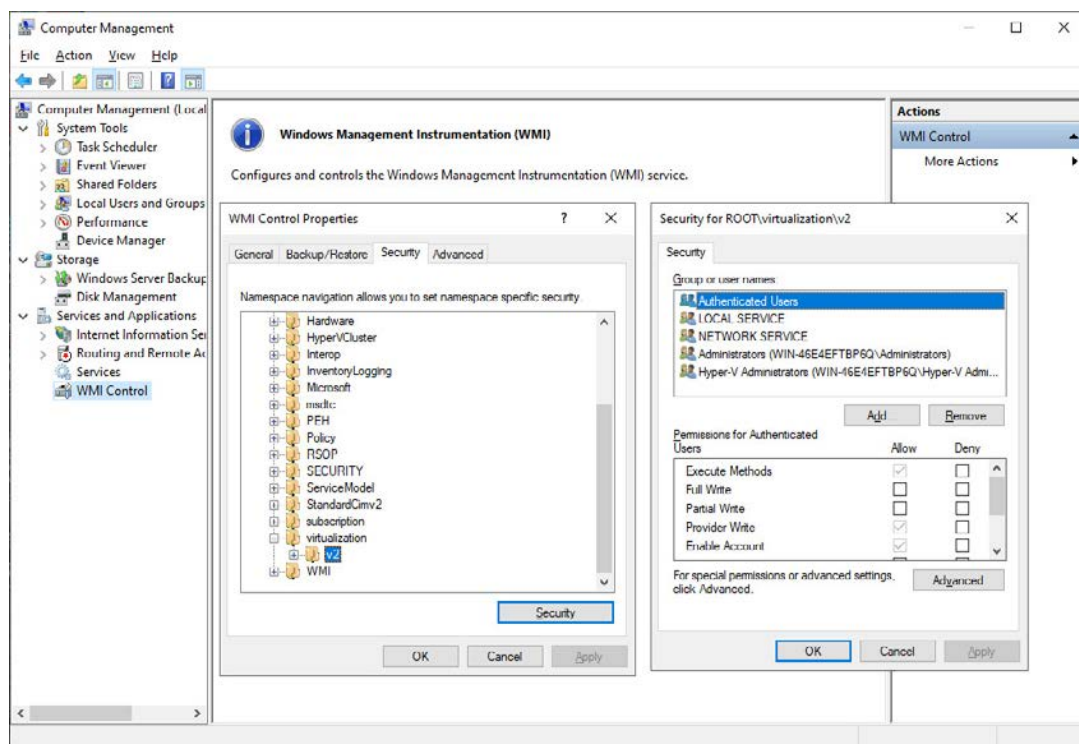

FIGURE 10-30 The WMI Control Properties application and the Security tab of the root\virtualization\v2 namespace.

Event Tracing for Windows (ETW)

Event Tracing for Windows (ETW) is the main facility that provides to applications and kernel-mode drivers the ability to provide, consume, and manage log and trace events. The events can be stored in a log file or in a circular buffer, or they can be consumed in real time. They can be used for debugging a driver, a framework like the .NET CLR, or an application and to understand whether there could be potential performance issues. The ETW facility is mainly implemented in the NT kernel, but an application can also use private loggers, which do not transition to kernel-mode at all. An application that uses ETW can be one of the following categories:

- **Controller** A controller starts and stops event tracing sessions, manages the size of the buffer pools, and enables providers so they can log events to the session. Example controllers include Reliability and Performance Monitor and XPerf from the Windows Performance Toolkit (now part of the Windows Assessment and Deployment Kit, available for download from <https://docs.microsoft.com/en-us/windows-hardware/get-started/adk-install>).
- **Provider** A provider is an application or a driver that contains event tracing instrumentation. A provider registers with ETW a provider GUID (globally unique identifiers), which defines the events it can produce. After the registration, the provider can generate events, which can be enabled or disabled by the controller application through an associated trace session.
- **Consumer** A consumer is an application that selects one or more trace sessions for which it wants to read trace data. Consumers can receive events stored in log files, in a circular buffer, or from sessions that deliver events in real time.

It's important to mention that in ETW, every provider, session, trait, and provider's group is represented by a GUID (more information about these concepts are provided later in this chapter). Four different technologies used for providing events are built on the top of ETW. They differ mainly in the method in which they store and define events (there are other distinctions though):

- MOF (or classic) providers are the legacy ones, used especially by WMI. MOF providers store the events descriptor in MOF classes so that the consumer knows how to consume them.
- WPP (Windows software trace processor) providers are used for tracing the operations of an application or driver (they are an extension of WMI event tracing) and use a TMF (trace message format) file for allowing the consumer to decode trace events.
- Manifest-based providers use an XML manifest file to define events that can be decoded by the consumer.
- TraceLogging providers, which, like WPP providers are used for fast tracing the operation of an application or driver, use self-describing events that contain all the required information for the consumption by the controller.

When first installed, Windows already includes dozens of providers, which are used by each component of the OS for logging diagnostics events and performance traces. For example, Hyper-V has multiple providers, which provide tracing events for the Hypervisor, Dynamic Memory, Vid driver, and Virtualization stack. As shown in Figure 10-31, ETW is implemented in different components:

- Most of the ETW implementation (global session creation, provider registration and enablement, main logging thread) resides in the NT kernel.
- The Host for SCM/SDDL/LSA Lookup APIs library (sechost.dll) provides to applications the main user-mode APIs used for creating an ETW session, enabling providers and consuming events. Sechost uses services provided by Ntdll to invoke ETW in the NT kernel. Some ETW user-mode APIs are implemented directly in Ntdll without exposing the functionality to Sechost. Provider registration and events generation are examples of user-mode functionalities that are implemented in Ntdll (and not in Sechost).
- The Event Trace Decode Helper Library (TDH.dll) implements services available for consumers to decode ETW events.
- The Eventing Consumption and Configuration library (WevtApi.dll) implements the Windows Event Log APIs (also known as Evt APIs), which are available to consumer applications for managing providers and events on local and remote machines. Windows Event Log APIs support XPath 1.0 or structured XML queries for parsing events produced by an ETW session.
- The Secure Kernel implements basic secure services able to interact with ETW in the NT kernel that lives in VTL 0. This allows trustlets and the Secure Kernel to use ETW for logging their own secure events.

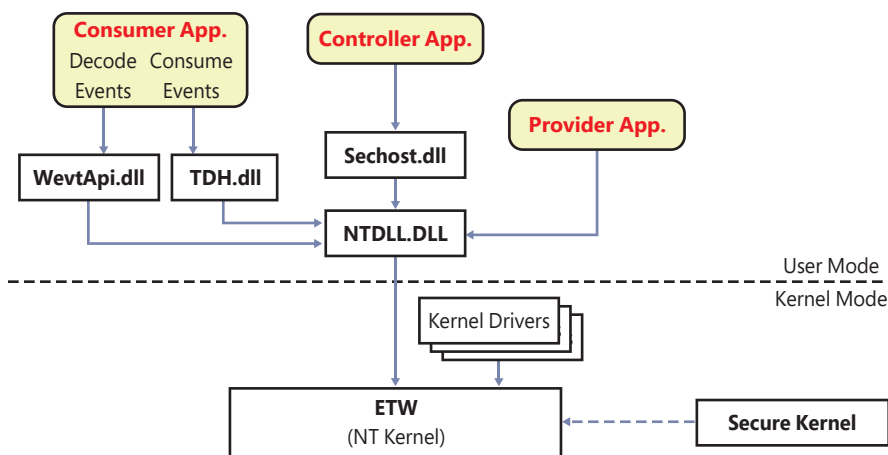

FIGURE 10-31 ETW architecture.

ETW initialization

The ETW initialization starts early in the NT kernel startup (for more details on the NT kernel initialization, see Chapter 12). It is orchestrated by the internal *EtwInitialize* function in three phases. The phase 0 of the NT kernel initialization calls *EtwInitialize* to properly allocate and initialize the per-silo ETW-specific data structure that stores the array of logger contexts representing global ETW sessions (see the “ETW session” section later in this chapter for more details). The maximum number of global sessions is queried from the HKLM\System\CurrentControlSet\Control\WMI\EtwMaxLoggers registry value, which should be between 32 and 256, (64 is the default number in case the registry value does not exist).

Later, in the NT kernel startup, the *IoInitSystemPreDrivers* routine of phase 1 continues with the initialization of ETW, which performs the following steps:

1. Acquires the system startup time and reference system time and calculates the QPC frequency.
2. Initializes the ETW security key and reads the default session and provider’s security descriptor.
3. Initializes the per-processor global tracing structures located in the PRCB.
4. Creates the real-time ETW consumer object type (called *EtwConsumer*), which is used to allow a user-mode real-time consumer process to connect to the main ETW logger thread and the ETW registration (internally called *EtwRegistration*) object type, which allow a provider to be registered from a user-mode application.
5. Registers the ETW bugcheck callback, used to dump logger sessions data in the bugcheck dump.
6. Initializes and starts the Global logger and Autologgers sessions, based on the *AutoLogger* and *GlobalLogger* registry keys located under the HKLM\System\CurrentControlSet\Control\WMI root key.
7. Uses the *EtwRegister* kernel API to register various NT kernel event providers, like the Kernel Event Tracing, General Events provider, Process, Network, Disk, File Name, IO, and Memory providers, and so on.
8. Publishes the ETW initialized WNF state name to indicate that the ETW subsystem is initialized.
9. Writes the *SystemStart* event to both the Global Trace logging and General Events providers. The event, which is shown in Figure 10-32, logs the approximate OS Startup time.
10. If required, loads the *FileInfo* driver, which provides supplemental information on files I/O to Superfetch (more information on the Proactive memory management is available in Chapter 5 of Part 1).

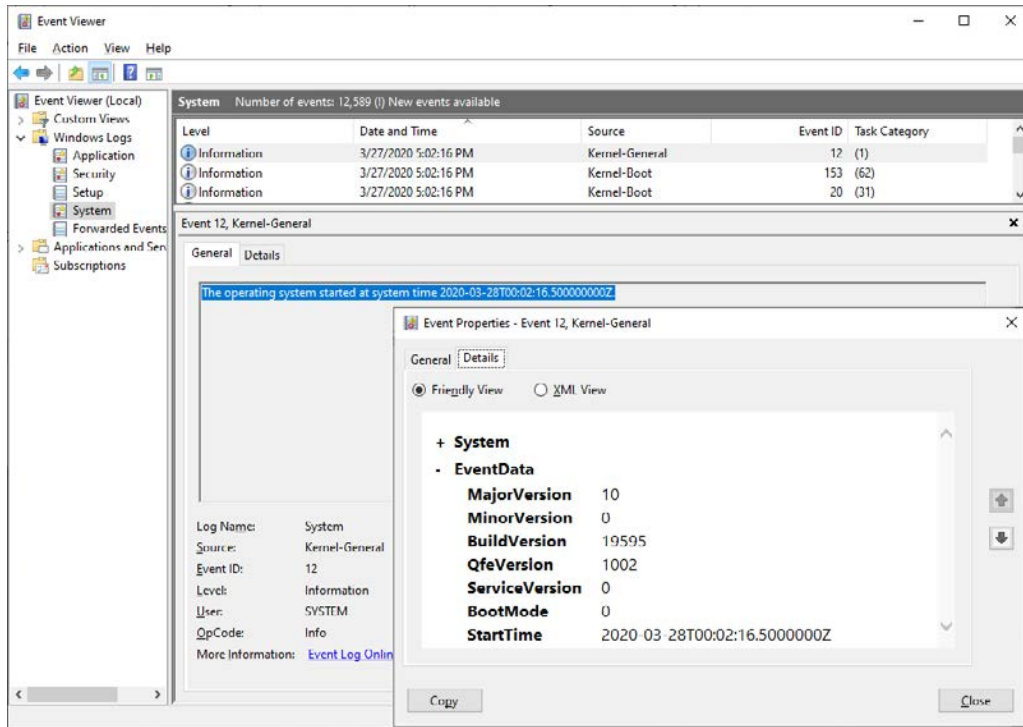

FIGURE 10-32 The SystemStart ETW event displayed by the Event Viewer.

In early boot phases, the Windows registry and I/O subsystems are still not completely initialized. So ETW can't directly write to the log files. Late in the boot process, after the Session Manager (SMSS.exe) has correctly initialized the software hive, the last phase of ETW initialization takes place. The purpose of this phase is just to inform each already-registered global ETW session that the file system is ready, so that they can flush out all the events that are recorded in the ETW buffers to the log file.

ETW sessions

One of the most important entities of ETW is the Session (internally called logger instance), which is a glue between providers and consumers. An event tracing session records events from one or more providers that a controller has enabled. A session usually contains all the information that describes which events should be recorded by which providers and how the events should be processed. For example, a session might be configured to accept all events from the Microsoft-Windows-Hyper-V-Hypervisor provider (which is internally identified using the {52fc89f8-995e-434c-a91e-199986449890} GUID). The user can also configure filters. Each event generated by a provider (or a provider group) can be filtered based on event level (information, warning, error, or critical), event keyword, event ID, and other characteristics. The session configuration can also define various other details for the session, such as what time source should be used for the event timestamps (for example, QPC, TSC, or system time), which events should have stack traces captured, and so on. The session has the important role to host the ETW logger thread, which is the main entity that flushes the events to the log file or delivers them to the real-time consumer.

Sessions are created using the *StartTrace* API and configured using *ControlTrace* and *EnableTraceEx2*. Command-line tools such as *xperf*, *logman*, *tracelog*, and *wevtutil* use these APIs to start or control trace sessions. A session also can be configured to be private to the process that creates it. In this case, ETW is used for consuming events created only by the same application that also acts as provider. The application thus eliminates the overhead associated with the kernel-mode transition. Private ETW sessions can record only events for the threads of the process in which it is executing and cannot be used with real-time delivery. The internal architecture of private ETW is not described in this book.

When a global session is created, the *StartTrace* API validates the parameters and copies them in a data structure, which the *NtTraceControl* API uses to invoke the internal function *EtwpStartLogger* in the kernel. An ETW session is represented internally through an *ETW_LOGGER_CONTEXT* data structure, which contains the important pointers to the session memory buffers, where the events are written to. As discussed in the “ETW initialization” section, a system can support a limited number of ETW sessions, which are stored in an array located in a global per-SILO data structure. *EtwpStartLogger* checks the global sessions array, determining whether there is free space or if a session with the same name already exists. If that is the case, it exits and signals an error. Otherwise, it generates a session GUID (if not already specified by the caller), allocates and initializes an *ETW_LOGGER_CONTEXT* data structure representing the session, assigns to it an index, and inserts it in the per-silo array.

ETW queries the session’s security descriptor located in the HKLM\System\CurrentControlSet\Control\Wmi\Security registry key. As shown in Figure 10-33, each registry value in the key is named as the session GUID (the registry key, however, also contains the provider’s GUID) and contains the binary representation of a self-relative security descriptor. If a security descriptor for the session does not exist, a default one is returned for the session (see the “Witnessing the default security descriptor of ETW sessions” experiment later in this chapter for details).

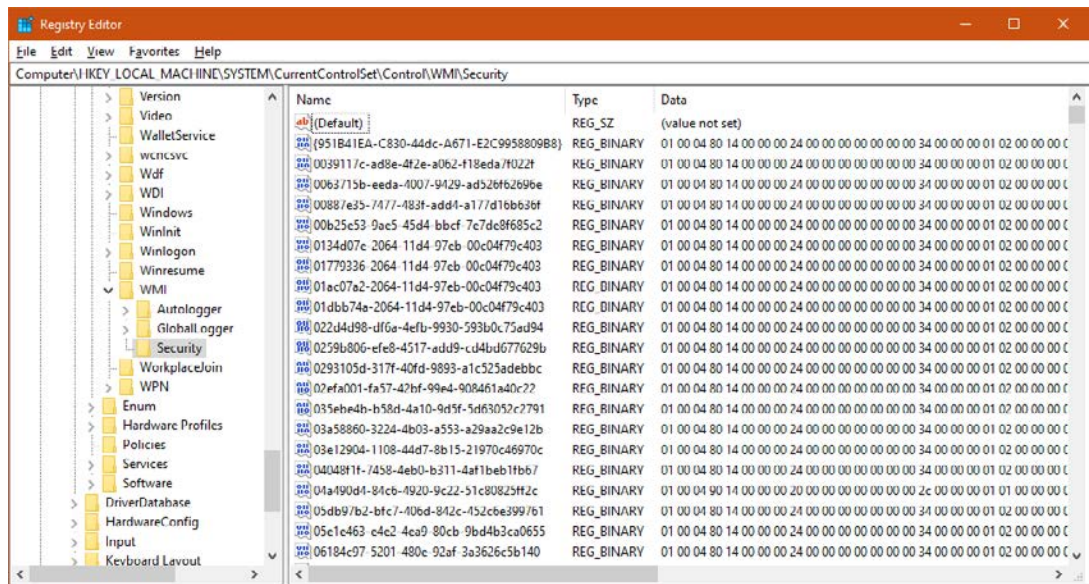

FIGURE 10-33 The ETW security registry key.

The *EtwpStartLogger* function performs an access check on the session's security descriptor, requesting the *TRACELOG_GUID_ENABLE* access right (and the *TRACELOG_CREATE_REALTIME* or *TRACELOG_CREATE_ONDISK* depending on the log file mode) using the current process's access token. If the check succeeds, the routine calculates the default size and numbers of event buffers, which are calculated based on the size of the system physical memory (the default buffer size is 8, 16, or 64KB). The number of buffers depends on the number of system processors and on the presence of the *EVENT_TRACE_NO_PER_PROCESSOR_BUFFERING* logger mode flag, which prevents events (which can be generated from different processors) to be written to a per-processor buffer.

ETW acquires the session's initial reference time stamp. Three clock resolutions are currently supported: Query performance counter (QPC, a high-resolution time stamp not affected by the system clock), System time, and CPU cycle counter. The *EtwpAllocateTraceBuffer* function is used to allocate each buffer associated with the logger session (the number of buffers was calculated before or specified as input from the user). A buffer can be allocated from the paged pool, nonpaged pool, or directly from physical large pages, depending on the logging mode. Each buffer is stored in multiple internal per-session lists, which are able to provide fast lookup both to the ETW main logger thread and ETW providers. Finally, if the log mode is not set to a circular buffer, the *EtwpStartLogger* function starts the main ETW logger thread, which has the goal of flushing events written by the providers associated with the session to the log file or to the real-time consumer. After the main thread is started, ETW sends a session notification to the registered session notification provider (GUID 2a6e185b-90de-4fc5-826c-9f44e608a427), a special provider that allows its consumers to be informed when certain ETW events happen (like a new session being created or destroyed, a new log file being created, or a log error being raised).

EXPERIMENT: Enumerating ETW sessions

In Windows 10, there are multiple ways to enumerate active ETW sessions. In this and all the next experiments regarding ETW, you will use the XPERF tool, which is part of the Windows Performance Toolkit distributed in the Windows Assessment and Deployment Kit (ADK), which is freely downloadable from <https://docs.microsoft.com/en-us/windows-hardware/get-started/adk-install>.

Enumerating active ETW sessions can be done in multiple ways. XPERF can do it while executed with the following command (usually XPERF is installed in C:\Program Files (x86)\Windows Kits\10\Windows Performance Toolkit):

```
xperf -Loggers
```

The output of the command can be huge, so it is strongly advised to redirect the output in a TXT file:

```
xperf -Loggers > ETW_Sessions.txt
```

The tool can decode and show in a human-readable form all the session configuration data. An example is given from the EventLog-Application session, which is used by the Event logger service (Wevtvc.dll) to write events in the Application.evtx file shown by the Event Viewer:

```
Logger Name       : EventLog-Application
Logger Id        : 9
Logger Thread Id  : 000000000000008C
Buffer Size      : 64
Maximum Buffers  : 64
Minimum Buffers  : 2
Number of Buffers : 2
Free Buffers     : 2
Buffers Written  : 252
Events Lost      : 0
Log Buffers Lost : 0
Real Time Buffers Lost: 0
Flush Timer      : 1
Age Limit        : 0
Real Time Mode   : Enabled
Log File Mode    : Secure PersistOnHybridShutdown PagedMemory IndependentSession
NoPerProcessorBuffering
Maximum File Size : 100
Log Filename     :
Trace Flags      : "Microsoft-Windows-CertificateServicesClient-Lifecycle-User":0x800
00000000000000:0xff+"Microsoft-Windows-SenseIR":0x8000000000000000:0xff+
... (output cut for space reasons)
```

The tool is also able to decode the name of each provider enabled in the session and the bitmask of event categories that the provider should write to the sessions. The interpretation of the bitmask (shown under “Trace Flags”) depends on the provider. For example, a provider can define that the category 1 (bit 0 set) indicates the set of events generated during initialization and cleanup, category 2 (bit 1 set) indicates the set of events generated when registry I/O is performed, and so on. The trace flags are interpreted differently for System sessions (see the “System loggers” section for more details.) In that case, the flags are decoded from the enabled kernel flags that specify which kind of kernel events the system session should log.

The Windows Performance Monitor, in addition to dealing with system performance counters, can easily enumerate the ETW sessions. Open Performance Monitor (by typing **perfmon** in the Cortana search box), expand the Data Collector Sets, and click Event Trace Sessions. The application should list the same sessions listed by XPERF. If you right-click a session’s name and select *Properties*, you should be able to navigate between the session’s configurations. In particular, the **Security** property sheet decodes the security descriptor of the ETW session.

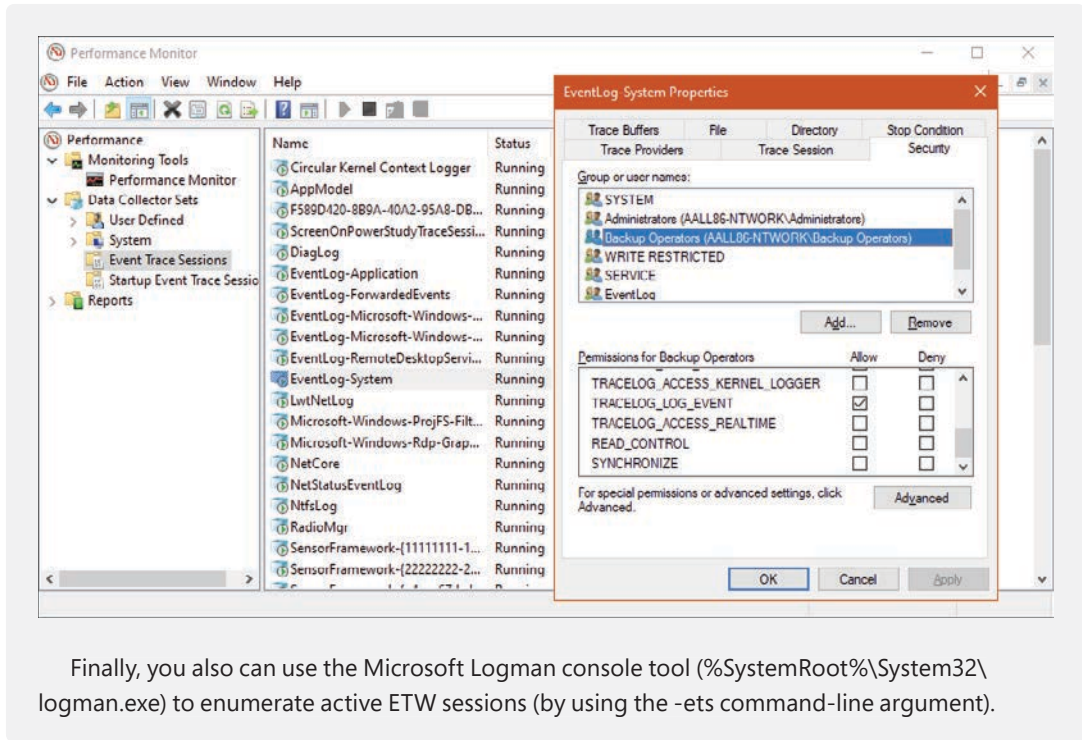

Finally, you also can use the Microsoft Logman console tool (`%SystemRoot%\System32\logman.exe`) to enumerate active ETW sessions (by using the `-ets` command-line argument).

ETW providers

As stated in the previous sections, a provider is a component that produces events (while the application that includes the provider contains event tracing instrumentation). ETW supports different kinds of providers, which all share a similar programming model. (They are mainly different in the way in which they encode events.) A provider must be initially registered with ETW before it can generate any event. In a similar way, a controller application should enable the provider and associate it with an ETW session to be able to receive events from the provider. If no session has enabled a provider, the provider will not generate any event. The provider defines its interpretation of being enabled or disabled. Generally, an enabled provider generates events, and a disabled provider does not.

Providers registration

Each provider's type has its own API that needs to be called by a provider application (or driver) for registering a provider. For example, manifest-based providers rely on the `EventRegister` API for user-mode registrations, and `EtwRegister` for kernel-mode registrations. All the provider types end up calling the internal `EtwpRegisterProvider` function, which performs the actual registration process (and is implemented in both the NT kernel and NTDLL). The latter allocates and initializes an `ETW_GUID_ENTRY` data structure, which represents the provider (the same data structure is used for notifications and traits). The data structure contains important information, like the provider GUID, security descriptor, reference counter, enablement information (for each ETW session that enables the provider), and a list of provider's registrations.

For user-mode provider registrations, the NT kernel performs an access check on the calling process's token, requesting the `TRACELOG_REGISTER_GUIDS` access right. If the check succeeds, or if the registration request originated from kernel code, ETW inserts the new `ETW_GUID_ENTRY` data structure in a hash table located in the global ETW per-silo data structure, using a hash of the provider's GUID as the table's key (this allows fast lookup of all the providers registered in the system.) In case an entry with the same GUID already exists in the hash table, ETW uses the existing entry instead of the new one. A GUID could already exist in the hash table mainly for two reasons:

- Another driver or application has enabled the provider before it has been actually registered (see the "Providers enablement" section later in this chapter for more details).
- The provider has been already registered once. Multiple registration of the same provider GUID are supported.

After the provider has been successfully added into the global list, ETW creates and initializes an ETW registration object, which represents a single registration. The object encapsulates an `ETW_REG_ENTRY` data structure, which ties the provider to the process and session that requested its registration. (ETW also supports registration from different sessions.) The object is inserted in a list located in the `ETW_GUID_ENTRY` (the `EtwRegistration` object type has been previously created and registered with the NT object manager at ETW initialization time). Figure 10-34 shows the two data structures and their relationships. In the figure, two providers' processes (process A, living in session 4, and process B, living in session 16) have registered for provider 1. Thus two `ETW_REG_ENTRY` data structures have been created and linked to the `ETW_GUID_ENTRY` representing provider 1.

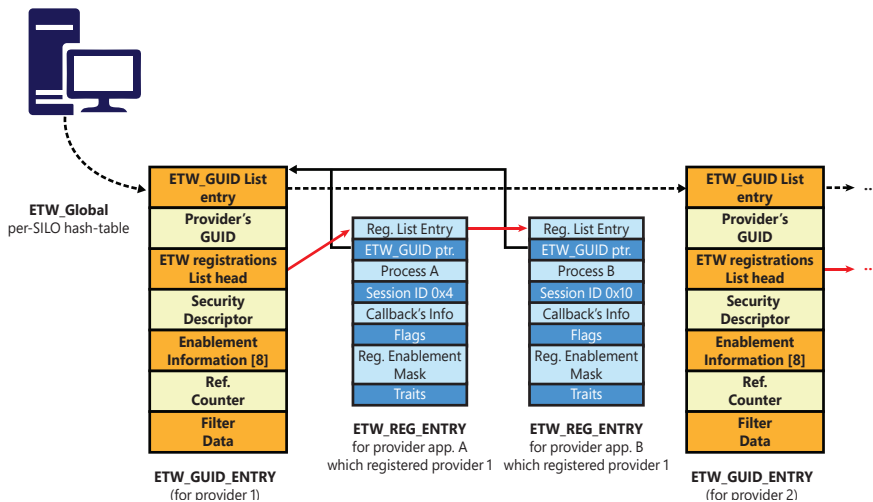

FIGURE 10-34 The `ETW_GUID_ENTRY` data structure and the `ETW_REG_ENTRY`.

At this stage, the provider is registered and ready to be enabled in the session(s) that requested it (through the `EnableTrace` API). In case the provider has been already enabled in at least one session before its registration, ETW enables it (see the next section for details) and calls the Enablement callback, which can be specified by the caller of the `EventRegister` (or `EtwRegister`) API that started the registration process.

EXPERIMENT: Enumerating ETW providers

As for ETW sessions, XPERF can enumerate the list of all the current registered providers (the WEVTUTIL tool, installed with Windows, can do the same). Open an administrative command prompt window and move to the Windows Performance Toolkit path. To enumerate the registered providers, use the `-providers` command option. The option supports different flags. For this experiment, you will be interested in the `I` and `R` flags, which tell XPERF to enumerate the installed or registered providers. As we will discuss in the “Decoding events” section later in this chapter, the difference is that a provider can be registered (by specifying a GUID) but not installed in the `HKLM\SOFTWARE\Microsoft\Windows\CurrentVersion\WINEVT\Publishers` registry key. This will prevent any consumer from decoding the event using TDH routines. The following commands

```
cd /d "C:\Program Files (x86)\Windows Kits\10\Windows Performance Toolkit"  
xperf -providers R > registered_providers.txt  
xperf -providers I > installed_providers.txt
```

produce two text files with similar information. If you open the `registered_providers.txt` file, you will find a mix of names and GUIDs. Names identify providers that are also installed in the Publisher registry key, whereas GUID represents providers that have just been registered through the *EventRegister* API discussed in this section. All the names are present also in the `installed_providers.txt` file with their respective GUIDs, but you won't find any GUID listed in the first text file in the installed providers list.

XPERF also supports the enumeration of all the kernel flags and groups supported by system loggers (discussed in the “System loggers” section later in this chapter) through the `K` flag (which is a superset of the `KF` and `KG` flags).

Provider Enablement

As introduced in the previous section, a provider should be associated with an ETW session to be able to generate events. This association is called Provider Enablement, and it can happen in two ways: before or after the provider is registered. A controller application can enable a provider on a session through the *EnableTraceEx* API. The API allows you to specify a bitmask of keywords that determine the category of events that the session wants to receive. In the same way, the API supports advanced filters on other kinds of data, like the process IDs that generate the events, package ID, executable name, and so on. (You can find more information at https://docs.microsoft.com/en-us/windows/win32/api/evntprov/ns-evtprov-event_filter_descriptor.)

Provider Enablement is managed by ETW in kernel mode through the internal *EtwpEnableGuid* function. For user-mode requests, the function performs an access check on both the session and provider security descriptors, requesting the `TRACELOG_GUID_ENABLE` access right on behalf of the calling process's token. If the logger session includes the `SECURITY_TRACE` flag, *EtwpEnableGuid* requires that the calling process is a PPL (see the “ETW security” section later in this chapter for more details). If the check succeeds, the function performs a similar task to the one discussed previously for provider registrations:

- It allocates and initializes an *ETW_GUID_ENTRY* data structure to represent the provider or use the one already linked in the global ETW per-silo data structure in case the provider has been already registered.
- Links the provider to the logger session by adding the relative session enablement information in the *ETW_GUID_ENTRY*.

In case the provider has not been previously registered, no ETW registration object exists that's linked in the *ETW_GUID_ENTRY* data structure, so the procedure terminates. (The provider will be enabled after it is first registered.) Otherwise, the provider is enabled.

While legacy MOF providers and WPP providers can be enabled only to one session at time, Manifest-based and Tracelogging providers can be enabled on a maximum of eight sessions. As previously shown in Figure 10-32, the *ETW_GUID_ENTRY* data structure contains enablement information for each possible ETW session that enabled the provider (eight maximum). Based on the enabled sessions, the *EtwpEnableGuid* function calculates a new session enablement mask, storing it in the *ETW_REG_ENTRY* data structure (representing the provider registration). The mask is very important because it's the key for event generations. When an application or driver writes an event to the provider, a check is made: if a bit in the enablement mask equals 1, it means that the event should be written to the buffer maintained by a particular ETW session; otherwise, the session is skipped and the event is not written to its buffer.

Note that for secure sessions, a supplemental access check is performed before updating the session enablement mask in the provider registration. The ETW session's security descriptor should allow the *TRACELOG_LOG_EVENT* access right to the calling process's access token. Otherwise, the relative bit in the enablement mask is not set to 1. (The target ETW session will not receive any event from the provider registration.) More information on secure sessions is available in the "Secure loggers and ETW security" section later in this chapter.

Providing events

After registering one or more ETW providers, a provider application can start to generate events. Note that events can be generated even though a controller application hasn't had the chance to enable the provider in an ETW session. The way in which an application or driver can generate events depends on the type of the provider. For example, applications that write events to manifest-based providers usually directly create an event descriptor (which respects the XML manifest) and use the *EventWrite* API to write the event to the ETW sessions that have the provider enabled. Applications that manage MOF and WPP providers rely on the *TraceEvent* API instead.

Events generated by manifest-based providers, as discussed previously in the "ETW session" section, can be filtered by multiple means. ETW locates the *ETW_GUID_ENTRY* data structure from the provider registration object, which is provided by the application through a handle. The internal *EtwpEventWriteFull* function uses the provider's registration session enablement mask to cycle between all the enabled ETW sessions associated with the provider (represented by an *ETW_LOGGER_CONTEXT*). For each session, it checks whether the event satisfies all the filters. If so, it calculates the full size of the event's payload and checks whether there is enough free space in the session's current buffer.

If there is no available space, ETW checks whether there is another free buffer in the session: free buffers are stored in a FIFO (first-in, first-out) queue. If there is a free buffer, ETW marks the old buffer as “dirty” and switches to the new free one. In this way, the Logger thread can wake up and flush the entire buffer to a log file or deliver it to a real-time consumer. If the session’s log mode is a circular logger, no logger thread is ever created: ETW simply links the old full buffer at the end of the free buffers queue (as a result the queue will never be empty). Otherwise, if there isn’t a free buffer in the queue, ETW tries to allocate an additional buffer before returning an error to the caller.

After enough space in a buffer is found, *EtwpEventWriteFull* atomically writes the entire event payload in the buffer and exits. Note that in case the session enablement mask is 0, it means that no sessions are associated with the provider. As a result, the event is lost and not logged anywhere.

MOF and WPP events go through a similar procedure but support only a single ETW session and generally support fewer filters. For these kinds of providers, a supplemental check is performed on the associated session: If the controller application has marked the session as secure, nobody can write any events. In this case, an error is yielded back to the caller (secure sessions are discussed later in the “Secure loggers and ETW security” section).

EXPERIMENT: Listing processes activity using ETW

In this experiment, will use ETW to monitor system’s processes activity. Windows 10 has two providers that can monitor this information: Microsoft-Windows-Kernel-Process and the NT kernel logger through the *PROC_THREAD* kernel flags. You will use the former, which is a classic provider and already has all the information for decoding its events. You can capture the trace with multiple tools. You still use XPERF (Windows Performance Monitor can be used, too).

Open a command prompt window and type the following commands:

```
cd /d "C:\Program Files (x86)\Windows Kits\10\Windows Performance Toolkit"  
xperf -start TestSession -on Microsoft-Windows-Kernel-Process -f c:\process_trace.etl
```

The command starts an ETW session called TestSession (you can replace the name) that will consume events generated by the Kernel-Process provider and store them in the C:\process_trace.etl log file (you can also replace the file name).

To verify that the session has actually started, repeat the steps described previously in the “Enumerating ETW sessions” experiment. (The TestSession trace session should be listed by both XPERF and the Windows Performance Monitor.) Now, you should start some new processes or applications (like Notepad or Paint, for example).

To stop the ETW session, use the following command:

```
xperf -stop TestSession
```

The steps used for decoding the ETL file are described later in the “Decoding an ETL file” experiment. Windows includes providers for almost all its components. The Microsoft-Windows-MSPaint provider, for example, generates events based on Paint’s functionality. You can try this experiment by capturing events from the MsPaint provider.

ETW Logger thread

The Logger thread is one of the most important entities in ETW. Its main purpose is to flush events to the log file or deliver them to the real-time consumer, keeping track of the number of delivered and lost events. A logger thread is started every time an ETW session is initially created, but only in case the session does not use the circular log mode. Its execution logic is simple. After it's started, it links itself to the *ETW_LOGGER_CONTEXT* data structure representing the associated ETW session and waits on two main synchronization objects. The Flush event is signaled by ETW every time a buffer belonging to a session becomes full (which can happen after a new event has been generated by a provider—for example, as discussed in the previous section, “Providing events”), when a new real-time consumer has requested to be connected, or when a logger session is going to be stopped. The Timeout timer is initialized to a valid value (usually 1 second) only in case the session is a real-time one or in case the user has explicitly required it when calling the *StartTrace* API for creating the new session.

When one of the two synchronization objects is signaled, the logger thread rearms them and checks whether the file system is ready. If not, the main logger thread returns to sleep again (no sessions should be flushed in early boot stages). Otherwise, it starts to flush each buffer belonging to the session to the log file or the real-time consumer.

For real-time sessions, the logger thread first creates a temporary per-session ETL file in the %SystemRoot%\System32\LogFiles\WMI\RtBackup folder (as shown in Figure 10-35.) The log file name is generated by adding the *EtwRT* prefix to the name of the real-time session. The file is used for saving temporary events before they are delivered to a real-time consumer (the log file can also store lost events that have not been delivered to the consumer in the proper time frame). When started, real-time auto-loggers restore lost events from the log file with the goal of delivering them to their consumer.

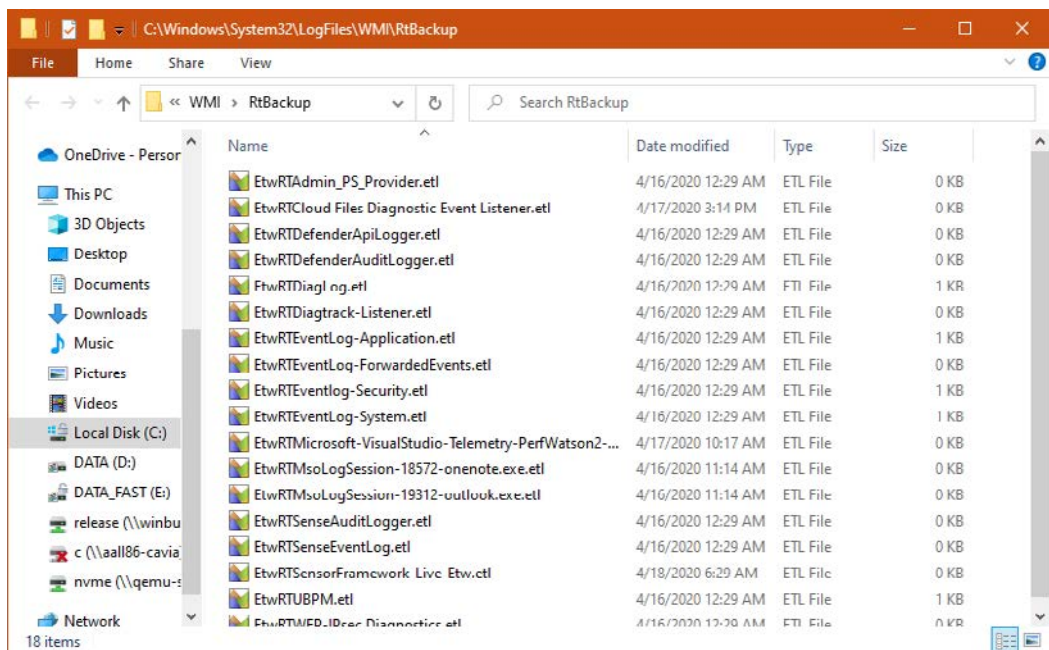

FIGURE 10-35 Real-time temporary ETL log files.

The logger thread is the only entity able to establish a connection between a real-time consumer and the session. The first time that a consumer calls the *ProcessTrace* API for receiving events from a real-time session, ETW sets up a new *RealTimeConsumer* object and uses it with the goal of creating a link between the consumer and the real-time session. The object, which resolves to an *ETW_REALTIME_CONSUMER* data structure in the NT kernel, allows events to be “injected” in the consumer’s process address space (another user-mode buffer is provided by the consumer application).

For non-real-time sessions, the logger thread opens (or creates, in case the file does not exist) the initial ETL log file specified by the entity that created the session. The logger thread can also create a brand-new log file in case the session’s log mode specifies the *EVENT_TRACE_FILE_MODE_NEWFILE* flag, and the current log file reaches the maximum size.

At this stage, the ETW logger thread initiates a flush of all the buffers associated with the session to the current log file (which, as discussed, can be a temporary one for real-time sessions). The flush is performed by adding an event header to each event in the buffer and by using the *NtWriteFile* API for writing the binary content to the ETL log file. For real-time sessions, the next time the logger thread wakes up, it is able to inject all the events stored in the temporary log file to the target user-mode real-time consumer application. Thus, for real-time sessions, ETW events are never delivered synchronously.

Consuming events

Events consumption in ETW is performed almost entirely in user mode by a consumer application, thanks to the services provided by the *Sechost.dll*. The consumer application uses the *OpenTrace* API for opening an ETL log file produced by the main logger thread or for establishing the connection to a real-time logger. The application specifies an event callback function, which is called every time ETW consumes a single event. Furthermore, for real-time sessions, the application can supply an optional buffer-callback function, which receives statistics for each buffer that ETW flushes and is called every time a single buffer is full and has been delivered to the consumer.

The actual event consumption is started by the *ProcessTrace* API. The API works for both standard and real-time sessions, depending on the log file mode flags passed previously to *OpenTrace*.

For real-time sessions, the API uses kernel mode services (accessed through the *NtTraceControl* system call) to verify that the ETW session is really a real-time one. The NT kernel verifies that the security descriptor of the ETW session grants the *TRACELOG_ACCESS_REALTIME* access right to the caller process’s token. If it doesn’t have access, the API fails and returns an error to the controller application. Otherwise, it allocates a temporary user-mode buffer and a bitmap used for receiving events and connects to the main logger thread (which creates the associated *EtwConsumer* object; see the “ETW logger thread” section earlier in this chapter for details). Once the connection is established, the API waits for new data arriving from the session’s logger thread. When the data comes, the API enumerates each event and calls the event callback.

For normal non-real-time ETW sessions, the *ProcessTrace* API performs a similar processing, but instead of connecting to the logger thread, it just opens and parses the ETL log file, reading each buffer one by one and calling the event callback for each found event (events are sorted in chronological order). Differently from real-time loggers, which can be consumed one per time, in this case the API

can work even with multiple trace handles created by the *OpenTrace* API, which means that it can parse events from different ETL log files.

Events belonging to ETW sessions that use circular buffers are not processed using the described methodology. (There is indeed no logger thread that dumps any event.) Usually a controller application uses the *FlushTrace* API when it wants to dump a snapshot of the current buffers belonging to an ETW session configured to use a circular buffer into a log file. The API invokes the NT kernel through the *NtTraceControl* system call, which locates the ETW session and verifies that its security descriptor grants the *TRACELOG_CREATE_ONDISK* access right to the calling process's access token. If so, and if the controller application has specified a valid log file name, the NT kernel invokes the internal *EtwpBufferingModeFlush* routine, which creates the new ETL file, adds the proper headers, and writes all the buffers associated with the session. A consumer application can then parse the events written in the new log file by using the *OpenTrace* and *ProcessTrace* APIs, as described earlier.

Events decoding

When the *ProcessTrace* API identifies a new event in an ETW buffer, it calls the event callback, which is generally located in the consumer application. To be able to correctly process the event, the consumer application should decode the event payload. The Event Trace Decode Helper Library (TDH.dll) provides services to consumer applications for decoding events. As discussed in the previous sections, a provider application (or driver), should include information that describes how to decode the events generated by its registered providers.

This information is encoded differently based on the provider type. Manifest-based providers, for example, compile the XML descriptor of their events in a binary file and store it in the resource section of their provider application (or driver). As part of provider registration, a setup application should register the provider's binary in the HKLM\SOFTWARE\Microsoft\Windows\CurrentVersion\WINEVT\Publishers registry key. The latter is important for event decoding, especially for the following reasons:

- The system consults the *Publishers* key when it wants to resolve a provider name to its GUID (from an ETW point of view, providers do not have a name). This allows tools like Xperf to display readable provider names instead of their GUIDs.
- The Trace Decode Helper Library consults the key to retrieve the provider's binary file, parse its resource section, and read the binary content of the events descriptor.

After the event descriptor is obtained, the Trace Decode Helper Library gains all the needed information for decoding the event (by parsing the binary descriptor) and allows consumer applications to use the *TdhGetEventInformation* API to retrieve all the fields that compose the event's payload and the correct interpretation the data associated with them. TDH follows a similar procedure for MOF and WPP providers (while TraceLogging incorporates all the decoding data in the event payload, which follows a standard binary format).

Note that all events are natively stored by ETW in an ETL log file, which has a well-defined uncompressed binary format and does not contain event decoding information. This means that if an ETL file is opened by another system that has not acquired the trace, there is a good probability that it will not be able to decode the events. To overcome these issues, the Event Viewer uses another binary format:

EVTX. This format includes all the events and their decoding information and can be easily parsed by any application. An application can use the *EvtExportLog* Windows Event Log API to save the events included in an ETL file with their decoding information in an EVTX file.

EXPERIMENT: Decoding an ETL file

Windows has multiple tools that use the *EvtExportLog* API to automatically convert an ETL log file and include all the decoding information. In this experiment, you use `netsh.exe`, but `TraceRpt.exe` also works well:

1. Open a command prompt and move to the folder where the ETL file produced by the previous experiment (“Listing processes activity using ETW”) resides and insert

```
netsh trace convert input=process_trace.etl output=process_trace.txt dump=txt
overwrite=yes
```

2. where `process_trace.etl` is the name of the input log file, and `process_trace.txt` file is the name of the output decoded text file.

3. If you open the text file, you will find all the decoded events (one for each line) with a description, like the following:

```
[2]1B0C.1154::2020-05-01 12:00:42.075601200 [Microsoft-Windows-Kernel-Process]
Process 1808 started at time 2020 - 05 - 01T19:00:42.075562700Z by parent 6924
running in session 1 with name \Device\HarddiskVolume4\Windows\System32\notepad.
exe.
```

4. From the log, you will find that rarely some events are not decoded completely or do not contain any description. This is because the provider manifest does not include the needed information (a good example is given from the `ThreadWorkOnBehalfUpdate` event). You can get rid of those events by acquiring a trace that does not include their keyword. The event keyword is stored in the CSV or EVTX file.

5. Use `netsh.exe` to produce an EVTX file with the following command:

```
netsh trace convert input=process_trace.etl output=process_trace.evtx dump=evtx
overwrite=yes
```

6. Open the Event Viewer. On the console tree located in the left side of the window, right-click the Event Viewer (Local) root node and select Open Saved Logs. Choose the just-created `process_trace.evtx` file and click Open.

7. In the Open Saved Log window, you should give the log a name and select a folder to display it. (The example accepted the default name, `process_trace` and the default Saved Logs folder.)

- The Event Viewer should now display each event located in the log file. Click the Date and Time column for ordering the events by Date and Time in ascending order (from the oldest one to the newest). Search for ProcessStart with Ctrl+F to find the event indicating the Notepad.exe process creation:

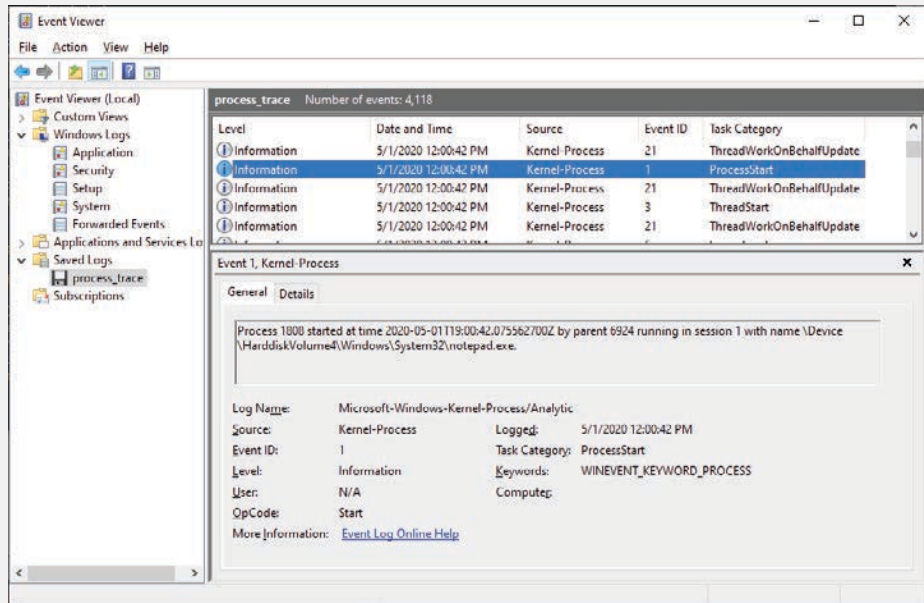

- The ThreadWorkOnBehalfUpdate event, which has no human-readable description, causes too much noise, and you should get rid of it from the trace. If you click one of those events and open the Details tab, in the System node, you will find that the event belongs to the WINEVENT_KEYWORD_WORK_ON_BEHALF category, which has a keyword bitmask set to 0x800000000002000. (Keep in mind that the highest 16 bits of the keywords are reserved for Microsoft-defined categories.) The bitwise NOT operation of the 0x800000000002000 64-bit value is 0x7FFFFFFFFFDFDF.
- Close the Event Viewer and capture another trace with XPERF by using the following command:

```
xperf -start TestSession -on Microsoft-Windows-Kernel-Process:0x7FFFFFFFFFDFDF -f c:\process_trace.etl
```
- Open Notepad or some other application and stop the trace as explained in the "Listing processes activity using ETW" experiment. Convert the ETL file to an EVTX. This time, the obtained decoded log should be smaller in size, and it does not contain ThreadWorkOnBehalfUpdate events.

System loggers

What we have described so far is how normal ETW sessions and providers work. Since Windows XP, ETW has supported the concepts of system loggers, which allow the NT kernel to globally emit log events that are not tied to any provider and are generally used for performance measurements. At the time of this writing, there are two main system loggers available, which are represented by the NT kernel logger and Circular Kernel Context Logger (while the Global logger is a subset of the NT kernel logger). The NT kernel supports a maximum of eight system logger sessions. Every session that receives events from a system logger is considered a system session.

To start a system session, an application makes use of the *StartTrace* API, but it specifies the *EVENT_TRACE_SYSTEM_LOGGER_MODE* flag or the GUID of a system logger session as input parameters. Table 10-16 lists the system logger with their GUIDs. The *EtwpStartLogger* function in the NT kernel recognizes the flag or the special GUIDs and performs an additional check against the NT kernel logger security descriptor, requesting the *TRACELOG_GUID_ENABLE* access right on behalf of the caller process access token. If the check passes, ETW calculates a system logger index and updates both the logger group mask and the system global performance group mask.

TABLE 10-16 System loggers

INDEX	Name	GUID	Symbol
0	NT kernel logger	{9e814aad-3204-11d2-9a82-006008a86939}	SystemTraceControlGuid
1	Global logger	{e8908abc-aa84-11d2-9a93-00805f85d7c6}	GlobalLoggerGuid
2	Circular Kernel Context Logger	{54dea73a-ed1f-42a4-af71-3e63d056f174}	CKCLGuid

The last step is the key that drives system loggers. Multiple low-level system functions, which can run at a high IRQL (the Context Swapper is a good example), analyzes the performance group mask and decides whether to write an event to the system logger. A controller application can enable or disable different events logged by a system logger by modifying the EnableFlags bit mask used by the *StartTrace* API and *ControlTrace* API. The events logged by a system logger are stored internally in the global performance group mask in a well-defined order. The mask is composed of an array of eight 32-bit values. Each index in the array represents a set of events. System event sets (also called Groups) can be enumerated using the Xperf tool. Table 10-17 lists the system logger events and the classification in their groups. Most of the system logger events are documented at https://docs.microsoft.com/en-us/windows/win32/api/evntrace/ns-evntrace-event_trace_properties.

TABLE 10-17 System logger events (kernel flags) and their group

Name	Description	Group
ALL_FAULTS	All page faults including hard, copy-on-write, demand-zero faults, and so on	None
ALPC	Advanced Local Procedure Call	None
CACHE_FLUSH	Cache flush events	None
CC	Cache manager events	None
CLOCKINT	Clock interrupt events	None
COMPACT_CSWSWITCH	Compact context switch	Diag
CONTMEMGEN	Contiguous memory generation	None
CPU_CONFIG	NUMA topology, processor group, and processor index	None
CSWITCH	Context switch	IOTrace
DEBUG_EVENTS	Debugger scheduling events	None
DISK_IO	Disk I/O	All except SysProf, ReferenceSet, and Network
DISK_IO_INIT	Disk I/O initiation	None
DISPATCHER	CPU scheduler	None
DPC	DPC events	Diag, DiagEasy, and Latency
DPC_QUEUE	DPC queue events	None
DRIVERS	Driver events	None
FILE_IO	File system operation end times and results	FileIO
FILE_IO_INIT	File system operation (create/open/close/read/write)	FileIO
FILENAME	FileName (e.g., FileName create/delete/rundown)	None
FLT_FASTIO	Minifilter fastio callback completion	None
FLT_IO	Minifilter callback completion	None
FLT_IO_FAILURE	Minifilter callback completion with failure	None
FLT_IO_INIT	Minifilter callback initiation	None
FOOTPRINT	Support footprint analysis	ReferenceSet
HARD_FAULTS	Hard page faults	All except SysProf and Network
HIBERRUNDOWN	Rundown(s) during hibernate	None
IDLE_STATES	CPU idle states	None
INTERRUPT	Interrupt events	Diag, DiagEasy, and Latency
INTERRUPT_STEER	Interrupt steering events	Diag, DiagEasy, and Latency
IPI	Inter-processor interrupt events	None
KE_CLOCK	Clock configuration events	None
KQUEUE	Kernel queue enqueue/dequeue	None
LOADER	Kernel and user mode image load/unload events	Base

Name	Description	Group
MEMINFO	Memory list info	Base, ResidentSet, and ReferenceSet
MEMINFO_WS	Working set info	Base and ReferenceSet
MEMORY	Memory tracing	ResidentSet and ReferenceSet
NETWORKTRACE	Network events (e.g., tcp/udp send/receive)	Network
OPTICAL_IO	Optical I/O	None
OPTICAL_IO_INIT	Optical I/O initiation	None
PERF_COUNTER	Process perf counters	Diag and DiagEasy
PMC_PROFILE	PMC sampling events	None
POOL	Pool tracing	None
POWER	Power management events	ResumeTrace
PRIORITY	Priority change events	None
PROC_THREAD	Process and thread create/delete	Base
PROFILE	CPU sample profile	SysProf
REFSET	Support footprint analysis	ReferenceSet
REG_HIVE	Registry hive tracing	None
REGISTRY	Registry tracing	None
SESSION	Session rundown/create/delete events	ResidentSet and ReferenceSet
SHOULDYIELD	Tracing for the cooperative DPC mechanism	None
SPINLOCK	Spinlock collisions	None
SPLIT_IO	Split I/O	None
SYSCALL	System calls	None
TIMER	Timer settings and its expiration	None
VAMAP	MapFile info	ResidentSet and ReferenceSet
VIRT_ALLOC	Virtual allocation reserve and release	ResidentSet and ReferenceSet
WDF_DPC	WDF DPC events	None
WDF_INTERRUPT	WDF Interrupt events	None

When the system session starts, events are immediately logged. There is no provider that needs to be enabled. This implies that a consumer application has no way to generically decode the event. System logger events use a precise event encoding format (called NTPERF), which depends on the event type. However, most of the data structures representing different NT kernel logger events are usually documented in the Windows platform SDK.

EXPERIMENT: Tracing TCP/IP activity with the kernel logger

In this experiment, you listen to the network activity events generated by the System Logger using the Windows Performance Monitor. As already introduced in the “Enumerating ETW sessions” experiment, the graphical tool is not just able to obtain data from the system performance counters but is also able to start, stop, and manage ETW sessions (system session included). To enable the kernel logger and have it generate a log file of TCP/IP activity, follow these steps:

1. Run the Performance Monitor (by typing **perfmon** in the Cortana search box) and click Data Collector Sets, User Defined.
2. Right-click User Defined, choose New, and select Data Collector Set.
3. When prompted, enter a name for the data collector set (for example, **experiment**), and choose **Create Manually (Advanced)** before clicking **Next**.
4. In the dialog box that opens, select **Create Data Logs**, check **Event Trace Data**, and then click **Next**. In the Providers area, click **Add**, and locate Windows Kernel Trace. Click **OK**. In the Properties list, select **Keywords (Any)**, and then click **Edit**.

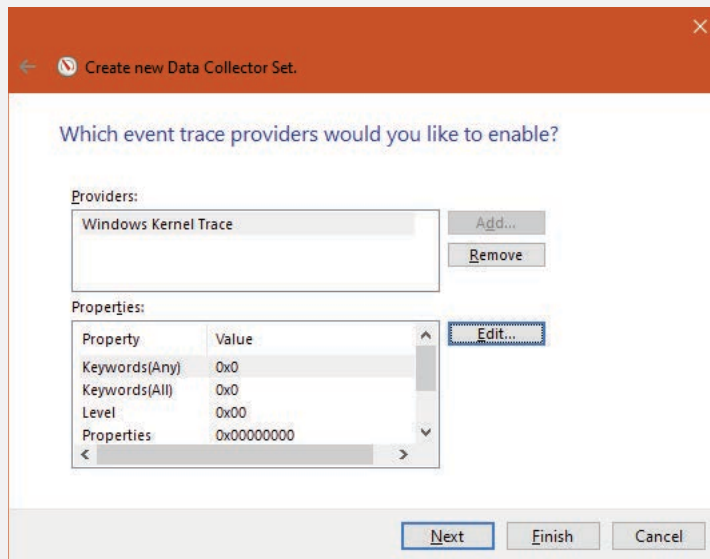

5. From the list shown in the **Property** window, select **Automatic** and check only net for Network TCP/IP, and then click **OK**.

6. Click **Next** to select a location where the files are saved. By default, this location is %SystemDrive%\PerfLogs\Admin\experiment\, if this is how you named the data collector set. Click **Next**, and in the **Run As** edit box, enter the Administrator account name and set the password to match it. Click **Finish**. You should now see a window similar to the one shown here:

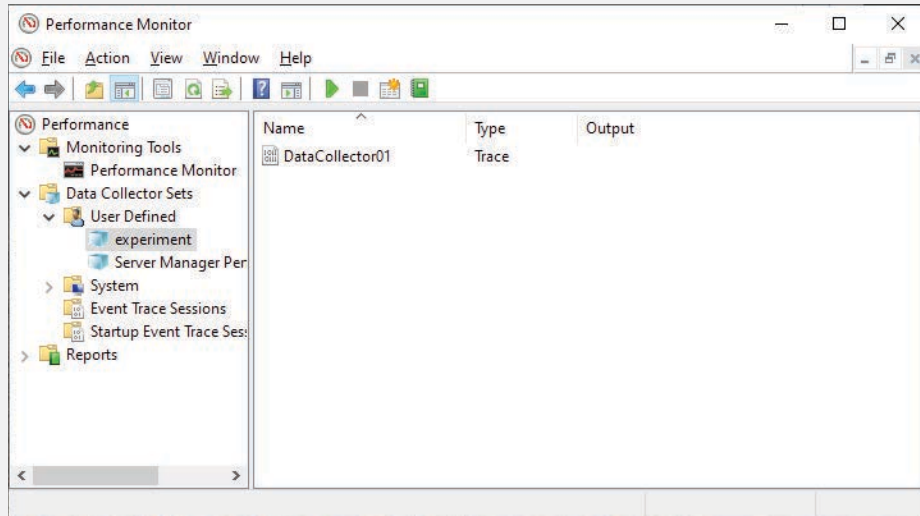

7. Right-click the name you gave your data collector set (experiment in our example), and then click Start. Now generate some network activity by opening a browser and visiting a website.
8. Right-click the data collector set node again and then click **Stop**.

If you follow the steps listed in the “Decoding an ETL file” experiment to decode the acquired ETL trace file, you will find that the best way to read the results is by using a CSV file type. This is because the System session does not include any decoding information for the events, so the netsh.exe has no regular way to encode the customized data structures representing events in the EVTX file.

Finally, you can repeat the experiment using XPERF with the following command (optionally replacing the C:\network.etl file with your preferred name):

```
xperf -on NETWORKTRACE -f c:\network.etl
```

After you stop the system trace session and you convert the obtained trace file, you will get similar events as the ones obtained with the Performance Monitor.

The Global logger and Autologgers

Certain logger sessions start automatically when the system boots. The Global logger session records events that occur early in the operating system boot process, including events generated by the NT kernel logger. (The Global logger is actually a system logger, as shown in Table 10-16.) Applications and device drivers can use the Global logger session to capture traces before the user logs in (some device drivers, such as disk device drivers, are not loaded at the time the Global logger session begins.) While the Global logger is mostly used to capture traces produced by the NT kernel provider (see Table 10-17), Autologgers are designed to capture traces from classic ETW providers (and not from the NT kernel logger).

You can configure the Global logger by setting the proper registry values in the *GlobalLogger* key, which is located in the HKLM\SYSTEM\CurrentControlSet\Control\WMI root key. In the same way, Autologgers can be configured by creating a registry subkey, named as the logging session, in the *Autologgers* key (located in the WMI root key). The procedure for configuring and starting Autologgers is documented at <https://docs.microsoft.com/en-us/windows/win32/etw/configuring-and-starting-an-Autologger-session>.

As introduced in the “ETW initialization” section previously in this chapter, ETW starts the Global logger and Autologgers almost at the same time, during the early phase 1 of the NT kernel initialization. The *EtwStartAutoLogger* internal function queries all the logger configuration data from the registry, validates it, and creates the logger session using the *EtwpStartLogger* routine, which has already been extensively discussed in the “ETW sessions” section. The Global logger is a system logger, so after the session is created, no further providers are enabled. Unlike the Global logger, Autologgers require providers to be enabled. They are started by enumerating each session’s name from the Autologger registry key. After a session is created, ETW enumerates the providers that should be enabled in the session, which are listed as subkeys of the Autologger key (a provider is identified by a GUID). Figure 10-36 shows the multiple providers enabled in the EventLog-System session. This session is one of the main Windows Logs displayed by the Windows Event Viewer (captured by the Event Logger service).

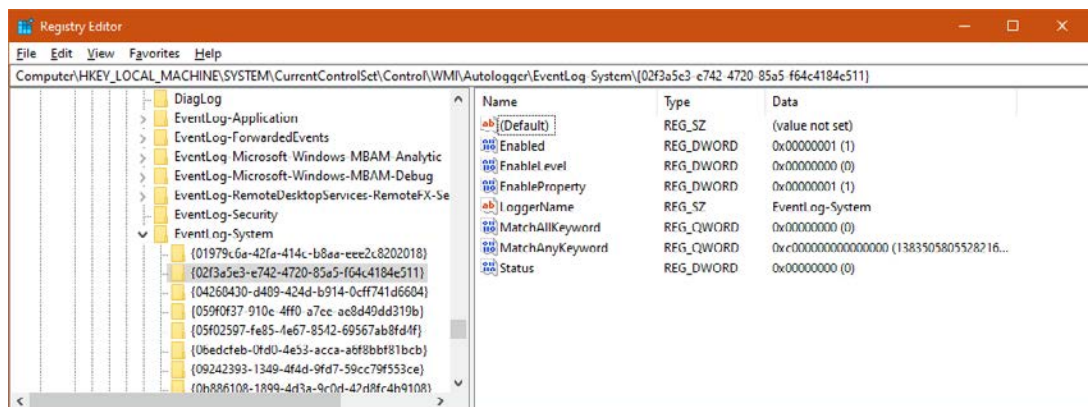

FIGURE 10-36 The EventLog-System Autologger’s enabled providers.

After the configuration data of a provider is validated, the provider is enabled in the session through the internal *EtwpEnableTrace* function, as for classic ETW sessions.

ETW security

Starting and stopping an ETW session is considered a high-privilege operation because events can include system data that can be used to exploit the system integrity (this is especially true for system loggers). The Windows Security model has been extended to support ETW security. As already introduced in previous sections, each operation performed by ETW requires a well-defined access right that must be granted by a security descriptor protecting the session, provider, or provider's group (depending on the operation). Table 10-18 lists all the new access rights introduced for ETW and their usage.

TABLE 10-18 ETW security access rights and their usage

Value	Description	Applied to
WMIGUID_QUERY	Allows the user to query information about the trace session	Session
WMIGUID_NOTIFICATION	Allows the user to send a notification to the session's notification provider	Session
TRACELOG_CREATE_REALTIME	Allows the user to start or update a real-time session	Session
TRACELOG_CREATE_ONDISK	Allows the user to start or update a session that writes events to a log file	Session
TRACELOG_GUID_ENABLE	Allows the user to enable the provider	Provider
TRACELOG_LOG_EVENT	Allows the user to log events to a trace session if the session is running in SECURE mode	Session
TRACELOG_ACCESS_REALTIME	Allows a consumer application to consume events in real time	Session
TRACELOG_REGISTER_GUIDS	Allows the user to register the provider (creating the <code>EtwRegistration</code> object backed by the <code>ETW_REG_ENTRY</code> data structure)	Provider
TRACELOG_JOIN_GROUP	Allows the user to insert a manifest-based or tracelogging provider to a Providers group (part of the ETW traits, which are not described in this book)	Provider

Most of the ETW access rights are automatically granted to the SYSTEM account and to members of the Administrators, Local Service, and Network Service groups. This implies that normal users are not allowed to interact with ETW (unless an explicit session and provider security descriptor allows it). To overcome the problem, Windows includes the Performance Log Users group, which has been designed to allow normal users to interact with ETW (especially for controlling trace sessions). Although all the ETW access rights are granted by the default security descriptor to the Performance Log Users group, Windows supports another group, called Performance Monitor Users, which has been designed only to receive or send notifications to the session notification provider. This is because the group has been designed to access system performance counters, enumerated by tools like Performance Monitor and Resource Monitor, and not to access the full ETW events. The two tools have been already described in the “Performance monitor and resource monitor” section of Chapter 1 in Part 1.

As previously introduced in the “ETW Sessions” section of this chapter, all the ETW security descriptors are stored in the `HKLM\System\CurrentControlSet\Control\Wmi\Security` registry key in a binary format. In ETW, everything that is represented by a GUID can be protected by a customized security descriptor. To manage ETW security, applications usually do not directly interact with security descriptors stored in the registry but use the `EventAccessControl` and `EventAccessQuery` APIs implemented in `Sechost.dll`.

EXPERIMENT: Witnessing the default security descriptor of ETW sessions

A kernel debugger can easily show the default security descriptor associated with ETW sessions that do not have a specific one associated with them. In this experiment, you need a Windows 10 machine with a kernel debugger already attached and connected to a host system. Otherwise, you can use a local kernel debugger, or LiveKd (downloadable from <https://docs.microsoft.com/en-us/sysinternals/downloads/livekd>.) After the correct symbols are configured, you should be able to dump the default SD using the following command:

```
!sd poi(nt!EtwDefaultTraceSecurityDescriptor)
```

The output should be similar to the following (cut for space reasons):

```
->Revision: 0x1
->Sbz1      : 0x0
->Control   : 0x8004
              SE_DACL_PRESENT
              SE_SELF_RELATIVE
->Owner     : S-1-5-32-544
->Group     : S-1-5-32-544
->DACL     :
->DACL     : ->AceRevision: 0x2
->DACL     : ->Sbz1       : 0x0
->DACL     : ->AceSize    : 0xf0
->DACL     : ->AceCount   : 0x9
->DACL     : ->Sbz2       : 0x0
->DACL     : ->Ace[0]: ->AceType: ACCESS_ALLOWED_ACE_TYPE
->DACL     : ->Ace[0]: ->AceFlags: 0x0
->DACL     : ->Ace[0]: ->AceSize: 0x14
->DACL     : ->Ace[0]: ->Mask  : 0x00001800
->DACL     : ->Ace[0]: ->SID   : S-1-1-0

->DACL     : ->Ace[1]: ->AceType: ACCESS_ALLOWED_ACE_TYPE
->DACL     : ->Ace[1]: ->AceFlags: 0x0
->DACL     : ->Ace[1]: ->AceSize: 0x14
->DACL     : ->Ace[1]: ->Mask  : 0x00120fff
->DACL     : ->Ace[1]: ->SID   : S-1-5-18

->DACL     : ->Ace[2]: ->AceType: ACCESS_ALLOWED_ACE_TYPE
->DACL     : ->Ace[2]: ->AceFlags: 0x0
->DACL     : ->Ace[2]: ->AceSize: 0x14
->DACL     : ->Ace[2]: ->Mask  : 0x00120fff
->DACL     : ->Ace[2]: ->SID   : S-1-5-19

->DACL     : ->Ace[3]: ->AceType: ACCESS_ALLOWED_ACE_TYPE
->DACL     : ->Ace[3]: ->AceFlags: 0x0
->DACL     : ->Ace[3]: ->AceSize: 0x14
->DACL     : ->Ace[3]: ->Mask  : 0x00120fff
->DACL     : ->Ace[3]: ->SID   : S-1-5-20

->DACL     : ->Ace[4]: ->AceType: ACCESS_ALLOWED_ACE_TYPE
->DACL     : ->Ace[4]: ->AceFlags: 0x0
->DACL     : ->Ace[4]: ->AceSize: 0x18
->DACL     : ->Ace[4]: ->Mask  : 0x00120fff
->DACL     : ->Ace[4]: ->SID   : S-1-5-32-544
```

```

->Dac1      : ->Ace[5]: ->AceType: ACCESS_ALLOWED_ACE_TYPE
->Dac1      : ->Ace[5]: ->AceFlags: 0x0
->Dac1      : ->Ace[5]: ->AceSize: 0x18
->Dac1      : ->Ace[5]: ->Mask : 0x00000ee5
->Dac1      : ->Ace[5]: ->SID: S-1-5-32-559

->Dac1      : ->Ace[6]: ->AceType: ACCESS_ALLOWED_ACE_TYPE
->Dac1      : ->Ace[6]: ->AceFlags: 0x0
->Dac1      : ->Ace[6]: ->AceSize: 0x18
->Dac1      : ->Ace[6]: ->Mask : 0x00000004
->Dac1      : ->Ace[6]: ->SID: S-1-5-32-558

```

You can use the Psgetsid tool (available at <https://docs.microsoft.com/en-us/sysinternals/downloads/psgetsid>) to translate the SID to human-readable names. From the preceding output, you can see that all ETW access is granted to the SYSTEM (S-1-5-18), LOCAL SERVICE (S-1-5-19), NETWORK SERVICE (S-1-5-18), and Administrators (S-1-5-32-544) groups. As explained in the previous section, the Performance Log Users group (S-1-5-32-559) has almost all ETW access, whereas the Performance Monitor Users group (S-1-5-32-558) has only the *WMIGUID_NOTIFICATION* access right granted by the session's default security descriptor.

```
C:\Users\andrea>psgetsid64 S-1-5-32-559
```

```
PsGetSid v1.45 - Translates SIDs to names and vice versa
Copyright (C) 1999-2016 Mark Russinovich
```

```
Sysinternals - www.sysinternals.com
```

```
Account for AALL86-LAPTOP\S-1-5-32-559:
Alias: BUILTIN\Performance Log Users
```

Security Audit logger

The Security Audit logger is an ETW session used by the Windows Event logger service (wevtvcs.dll) to listen for events generated by the Security Lsass Provider. The Security Lsass provider (which is identified by the {54849625-5478-4994-a5ba-3e3b0328c30d} GUID) can be registered only by the NT kernel at ETW initialization time and is never inserted in the global provider's hash table. Only the Security audit logger and Autologgers configured with the *EnableSecurityProvider* registry value set to 1 can receive events from the Security Lsass Provider. When the *EtwStartAutoLogger* internal function encounters the value set to 1, it enables the *SECURITY_TRACE* flag on the associated ETW session, adding the session to the list of loggers that can receive Security audit events.

The flag also has the important effect that user-mode applications can't query, stop, flush, or control the session anymore, unless they are running as protected process light (at the antimalware, Windows, or WinTcb level; further details on protected processes are available in Chapter 3 of Part 1).

Secure loggers

Classic (MOF) and WPP providers have not been designed to support all the security features implemented for manifest-based and tracing logging providers. An Autologger or a generic ETW session can

thus be created with the `EVENT_TRACE_SECURE_MODE` flag, which marks the session as secure. A secure session has the goal of ensuring that it receives events only from trusted identities. The flag has two main effects:

- Prevents classic (MOF) and WPP providers from writing any event to the secure session. If a classic provider is enabled in a secure section, the provider won't be able to generate any events.
- Requires the supplemental `TRACELOG_LOG_EVENT` access right, which should be granted by the session's security descriptor to the controller application's access token while enabling a provider to the secure session.

The `TRACE_LOG_EVENT` access right allows a more-granular security to be specified in a session's security descriptor. If the security descriptor grants only the `TRACELOG_GUID_ENABLE` to an untrusted user, and the ETW session is created as secure by another entity (a kernel driver or a more privileged application), the untrusted user can't enable any provider on the secure section. If the section is created as nonsecure, the untrusted user can enable any providers on it.

Dynamic tracing (DTrace)

As discussed in the previous section, Event Tracing for Windows is a powerful tracing technology integrated into the OS, but it's *static*, meaning that the end user can only trace and log events that are generated by well-defined components belonging to the operating system or to third-party frameworks/applications (.NET CLR, for example.) To overcome the limitation, the May 2019 Update of Windows 10 (19H1) introduced DTrace, the dynamic tracing facility built into Windows. DTrace can be used by administrators on live systems to examine the behavior of both user programs and of the operating system itself. DTrace is an open-source technology that was developed for the Solaris operating system (and its descendant, illumos, both of which are Unix-based) and ported to several operating systems other than Windows.

DTrace can dynamically trace parts of the operating system and user applications at certain locations of interest, called *probes*. A probe is a binary code location or activity to which DTrace can bind a request to perform a set of actions, like logging messages, recording a stack trace, a timestamp, and so on. When a probe *fires*, DTrace gathers the data from the probe and executes the actions associated with the probe. Both the probes and the actions are specified in a script file (or directly in the DTrace application through the command line), using the D programming language. Support for probes are provided by kernel modules, called *providers*. The original illumos DTrace supported around 20 providers, which were deeply tied to the Unix-based OS. At the time of this writing, Windows supports the following providers:

- **SYSCALL** Allows the tracing of the OS system calls (both on entry and on exit) invoked from user-mode applications and kernel-mode drivers (through `Zw*` APIs).
- **FBT** (Function Boundary tracing) Through FBT, a system administrator can trace the execution of individual functions implemented in all the modules that run in the NT kernel.
- **PID** (User-mode process tracing) The provider is similar to FBT and allows tracing of individual functions of a user-mode process and application.

- **ETW** (Event Tracing for Windows) DTrace can use this provider to attach to manifest-based and TraceLogging events fired from the ETW engine. DTrace is able to define new ETW providers and provide associated ETW events via the `etw_trace` action (which is not part of any provider).
- **PROFILE** Provides probes associated with a time-based interrupt firing every fixed, specified time interval.
- **DTRACE** Built-in provider is implicitly enabled in the DTrace engine.

The listed providers allow system administrators to dynamically trace almost every component of the Windows operating system and user-mode applications.



Note There are big differences between the first version of DTrace for Windows, which appeared in the May 2019 Update of Windows 10, and the current stable release (distributed at the time of this writing in the May 2021 edition of Windows 10). One of the most notable differences is that the first release required a kernel debugger to be set up to enable the FBT provider. Furthermore, the ETW provider was not completely available in the first release of DTrace.

EXPERIMENT: Enabling DTrace and listing the installed providers

In this experiment, you install and enable DTrace and list the providers that are available for dynamically tracing various Windows components. You need a system with Windows 10 May 2020 Update (20H1) or later installed. As explained in the Microsoft documentation (<https://docs.microsoft.com/en-us/windows-hardware/drivers/devtest/dtrace>), you should first enable DTrace by opening an administrative command prompt and typing the following command (remember to disable Bitlocker, if it is enabled):

```
bcdedit /set dtrace ON
```

After the command succeeds, you can download the DTrace package from <https://www.microsoft.com/download/details.aspx?id=100441> and install it. Restart your computer (or virtual machine) and open an administrative command prompt (by typing **CMD** in the Cortana search box and selecting **Run As Administrator**). Type the following commands (replacing `providers.txt` with another file name if desired):

```
cd /d "C:\Program Files\DTrace"
dtrace -l > providers.txt
```

Open the generated file (`providers.txt` in the example). If DTrace has been successfully installed and enabled, a list of probes and providers (DTrace, `syscall`, and ETW) should be listed in the output file. Probes are composed of an ID and a human-readable name. The human-readable name is composed of four parts. Each part may or may not exist, depending on the provider. In general, providers try to follow the convention as close as possible, but in some cases the meaning of each part can be overloaded with something different:

- **Provider** The name of the DTrace provider that is publishing the probe.

- **Module** If the probe corresponds to a specific program location, the name of the module in which the probe is located. The module is used only for the PID (which is not shown in the output produced by the **dtrace -I** command) and ETW provider.
- **Function** If the probe corresponds to a specific program location, the name of the program function in which the probe is located.
- **Name** The final component of the probe name is a name that gives you some idea of the probe's semantic meaning, such as BEGIN or END.

When writing out the full human-readable name of a probe, all the parts of the name are separated by colons. For example,

```
syscall::NtQuerySystemInformation:entry
```

specifies a probe on the *NtQueryInformation* function entry provided by the syscall provider. Note that in this case, the module name is empty because the syscall provider does not specify any name (all the syscalls are implicitly provided by the NT kernel).

The PID and FBT providers instead dynamically generate probes based on the process or kernel image to which they are applied (and based on the currently available symbols). For example, to correctly list the PID probes of a process, you should first get the process ID (PID) of the process that you want to analyze (by simply opening the Task Manager and selecting the Details property sheet; in this example, we are using Notepad, which in the test system has PID equal to 8020). Then execute DTrace with the following command:

```
dtrace -ln pid8020:::entry > pid_notepad.txt
```

This lists all the probes on function entries generated by the PID provider for the Notepad process. The output will contain a lot of entries. Note that if you do not have the symbol store path set, the output will not contain any probes generated by private functions. To restrict the output, you can add the name of the module:

```
dtrace.exe -ln pid8020:kernelbase::entry >pid_kernelbase_notepad.txt
```

This yields all the PID probes generated for function entries of the kernelbase.dll module mapped in Notepad. If you repeat the previous two commands after having set the symbol store path with the following command,

```
set _NT_SYMBOL_PATH=srv*C:\symbols*http://msdl.microsoft.com/download/symbols
```

you will find that the output is much different (and also probes on private functions).

As explained in the “The Function Boundary Tracing (FBT) and Process (PID) providers” section later in this chapter, the PID and FBT provider can be applied to any offset in a function's code. The following command returns all the offsets (always located at instruction boundary) in which the PID provider can generate probes on the *SetComputerNameW* function of Kernelbase.dll:

```
dtrace.exe -ln pid8020:kernelbase:SetComputerNameW:
```

Internal architecture

As explained in the “Enabling DTrace and listing the installed providers” experiment earlier in this chapter, in Windows 10 May 2020 Update (20H1), some components of DTrace should be installed through an external package. Future versions of Windows may integrate DTrace completely in the OS image. Even though DTrace is deeply integrated in the operating system, it requires three external components to work properly. These include both the NT-specific implementation and the original DTrace code released under the free Common Development and Distribution License (CDDL), which is downloadable from <https://github.com/microsoft/DTrace-on-Windows/tree/windows>.

As shown in Figure 10-37, DTrace in Windows is composed of the following components:

- **DTrace.sys** The DTrace extension driver is the main component that executes the actions associated with the probes and stores the results in a circular buffer that the user-mode application obtains via IOCTLS.
- **DTrace.dll** The module encapsulates LibDTrace, which is the DTrace user-mode engine. It implements the Compiler for the D scripts, sends the IOCTLS to the DTrace driver, and is the main consumer of the circular DTrace buffer (where the DTrace driver stores the output of the actions).
- **DTrace.exe** The entry point executable that dispatches all the possible commands (specified through the command line) to the LibDTrace.

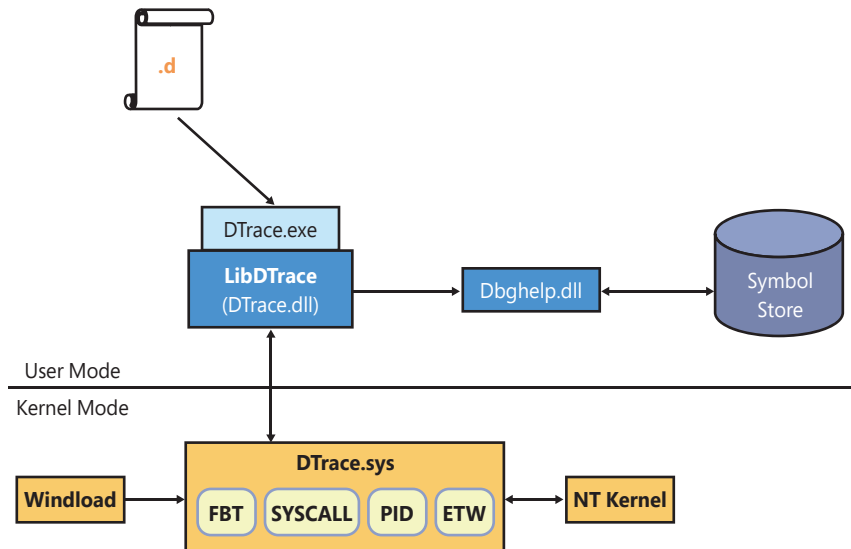

FIGURE 10-37 DTrace internal architecture.

To start the dynamic trace of the Windows kernel, a driver, or a user-mode application, the user just invokes the DTrace.exe main executable specifying a command or an external D script. In both cases, the command or the file contain one or more probes and additional actions expressed in the D programming language. DTrace.exe parses the input command line and forwards the proper request

to the LibDTrace (which is implemented in DTrace.dll). For example, when started for enabling one or more probes, the DTrace executable calls the internal *dtrace_program_fcompile* function implemented in LibDTrace, which compiles the D script and produces the DTrace Intermediate Format (DIF) bytecode in an output buffer.



Note Describing the details of the DIF bytecode and how a D script (or D commands) is compiled is outside the scope of this book. Interested readers can find detailed documentation in the *OpenDTrace Specification* book (released by the University of Cambridge), which is available at <https://www.cl.cam.ac.uk/techreports/UCAM-CL-TR-924.pdf>.

While the D compiler is entirely implemented in user-mode in LibDTrace, to execute the compiled DIF bytecode, the LibDTrace module just sends the *DTRACEIOC_ENABLE_IOCTL* to the DTrace driver, which implements the DIF virtual machine. The DIF virtual machine is able to evaluate each D clause expressed in the bytecode and to execute optional actions associated with them. A limited set of actions are available, which are executed through native code and not interpreted via the D virtual machine.

As shown earlier in Figure 10-37, the DTrace extension driver implements all the providers. Before discussing how the main providers work, it is necessary to present an introduction of the DTrace initialization in the Windows OS.

DTrace initialization

The DTrace initialization starts in early boot stages, when the Windows loader is loading all the modules needed for the kernel to correctly start. One important part to load and validate is the API set file (*apisetschema.dll*), which is a key component of the Windows system. (API Sets are described in Chapter 3 of part 1.) If the *DTRACE_ENABLED* BCD element is set in the boot entry (value *0x26000145*, which can be set through the *dtrace* readable name; see Chapter 12 for more details about BCD objects), the Windows loader checks whether the *dtrace.sys* driver is present in the *%SystemRoot%\System32\Drivers* path. If so, it builds a new API Set schema extension named *ext-ms-win-ntos-trace-l1-1-0*. The schema targets the *Dtrace.sys* driver and is merged into the system API set schema (*OsApiSetSchema*).

Later in the boot process, when the NT kernel is starting its phase 1 of initialization, the *TracelnitSystem* function is called to initialize the Dynamic Tracing subsystem. The API is imported in the NT kernel through the *ext-ms-win-ntos-trace-l1-1-0.dll* API set schema. This implies that if DTrace is not enabled by the Windows loader, the name resolution would fail, and the function will be basically a no op.

The *TracelnitSystem* has the important duty of calculating the content of the trace callouts array, which contains the functions that will be called by the NT kernel when a trace probe fires. The array is stored in the *KiDynamicTraceCallouts* global symbol, which will be later protected by Patchguard to prevent malicious drivers from illegally redirecting the flow of execution of system routines. Finally, through the *TracelnitSystem* function, the NT kernel sends to the DTrace driver another important array, which contains private system interfaces used by the DTrace driver to apply the probes. (The array is exposed in a trace extension context data structure.) This kind of initialization, where both the DTrace driver and the NT kernel exchange private interfaces, is the main motivation why the DTrace driver is called an extension driver.

The Pnp manager later starts the DTrace driver, which is installed in the system as boot driver, and calls its main entry point (*DriverEntry*). The routine registers the `\Device\DTrace` control device and its symbolic link (`\GLOBAL??\DTrace`). It then initializes the internal DTrace state, creating the first DTrace built-in provider. It finally registers all the available providers by calling the initialization function of each of them. The initialization method depends on each provider and usually ends up calling the internal *dtrace_register* function, which registers the provider with the DTrace framework. Another common action in the provider initialization is to register a handler for the control device. User-mode applications can communicate with DTrace and with a provider through the DTrace control device, which exposes virtual files (handlers) to providers. For example, the user-mode LibDTrace communicates directly with the PID provider by opening a handle to the `\\.\DTrace\Fasttrap` virtual file (handler).

The syscall provider

When the syscall provider gets activated, DTrace ends up calling the *KeSetSystemServiceCallback* routine, with the goal of activating a callback for the system call specified in the probe. The routine is exposed to the DTrace driver thanks to the NT system interfaces array. The latter is compiled by the NT kernel at DTrace initialization time (see the previous section for more details) and encapsulated in an extension context data structure internally called *KiDynamicTraceContext*. The first time that the *KeSetSystemServiceCallback* is called, the routine has the important task of building the global service trace table (*KiSystemServiceTraceCallbackTable*), which is an RB (red-black) tree containing descriptors of all the available syscalls. Each descriptor includes a hash of the syscall's name, its address, and number of parameters and flags indicating whether the callback is enabled on entry or on exit. The NT kernel includes a static list of syscalls exposed through the *KiServicesTab* internal array.

After the global service trace table has been filled, the *KeSetSystemServiceCallback* calculates the hash of the syscall's name specified by the probe and searches the hash in the RB tree. If there are no matches, the probe has specified a wrong syscall name (so the function exits signaling an error). Otherwise, the function modifies the enablement flags located in the found syscall's descriptor and increases the number of the enabled trace callbacks (which is stored in an internal variable).

When the first DTrace syscall callback is enabled, the NT kernel sets the syscall bit in the global *KiDynamicTraceMask* bitmask. This is very important because it enables the system call handler (*KiSystemCall64*) to invoke the global trace handlers. (System calls and system service dispatching have been discussed extensively in Chapter 8.)

This design allows DTrace to coexist with the system call handling mechanism without having any sort of performance penalty. If no DTrace syscall probe is active, the trace handlers are not invoked. A trace handler can be called on entry and on exit of a system call. Its functionality is simple. It just scans the global service trace table looking for the descriptor of the system call. When it finds the descriptor, it checks whether the enablement flag is set and, if so, invokes the correct callout (contained in the global dynamic trace callout array, *KiDynamicTraceCallouts*, as specified in the previous section). The callout, which is implemented in the DTrace driver, uses the generic internal *dtrace_probe* function to fire the syscall probe and execute the actions associated with it.

The Function Boundary Tracing (FBT) and Process (PID) providers

Both the FBT and PID providers are similar because they allow a probe to be enabled on any function entry and exit points (not necessarily a syscall). The target function can reside in the NT kernel or as part of a driver (for these cases, the FBT provider is used), or it can reside in a user-mode module, which should be executed by a process. (The PID provider can trace user-mode applications.) An FBT or PID probe is activated in the system through breakpoint opcodes (INT 3 in x86, BRK in ARM64) that are written directly in the target function's code. This has the following important implications:

- When a PID or FBT probe raises, DTrace should be able to re-execute the replaced instruction before calling back the target function. To do this, DTrace uses an instruction emulator, which, at the time of this writing, is compatible with the AMD64 and ARM64 architecture. The emulator is implemented in the NT kernel and is normally invoked by the system exception handler while dealing with a breakpoint exception.
- DTrace needs a way to identify functions by name. The name of a function is never compiled in the final binary (except for exported functions). DTrace uses multiple techniques to achieve this, which will be discussed in the "DTrace type library" section later in this chapter.
- A single function can exit (return) in multiple ways from different code branches. To identify the exit points, a function graph analyzer is required to disassemble the function's instructions and find each exit point. Even though the original function graph analyzer was part of the Solaris code, the Windows implementation of DTrace uses a new optimized version of it, which still lives in the LibDTrace library (DTrace.dll). While user-mode functions are analyzed by the function graph analyzer, DTrace uses the PDATA v2 unwind information to reliably find kernel-mode function exit points (more information on function unwinds and exception dispatching is available in Chapter 8). If the kernel-mode module does not make use of PDATA v2 unwind information, the FBT provider will not create any probes on function returns for it.

DTrace installs FBT or PID probes by calling the *KeSetTracepoint* function of the NT kernel exposed through the NT System interfaces array. The function validates the parameters (the callback pointer in particular) and, for kernel targets, verifies that the target function is located in an executable code section of a known kernel-mode module. Similar to the syscall provider, a *KI_TRACEPOINT_ENTRY* data structure is built and used for keeping track of the activated trace points. The data structure contains the owning process, access mode, and target function address. It is inserted in a global hash table, *KiTpHashTable*, which is allocated at the first time an FBT or PID probe gets activated. Finally, the single instruction located in the target code is parsed (imported in the emulator) and replaced with a breakpoint opcode. The trap bit in the global *KiDynamicTraceMask* bitmask is set.

For kernel-mode targets, the breakpoint replacement can happen only when VBS (Virtualization Based Security) is enabled. The *MmWriteSystemImageTracepoint* routine locates the loader data table entry associated with the target function and invokes the *SECURESERVICE_SET_TRACEPOINT* secure call. The Secure Kernel is the only entity able to collaborate with HyperGuard and thus to render the breakpoint application a legit code modification. As explained in Chapter 7 of Part 1, Kernel Patch protection (also known as Patchguard) prevents any code modification from being performed on the NT kernel and some essential kernel drivers. If VBS is not enabled on the system, and a debugger is not attached, an error code is returned, and the probe application fails. If a kernel debugger is attached,

the breakpoint opcode is applied by the NT kernel through the *MmDbgCopyMemory* function. (Patchguard is not enabled on debugged systems.)

When called for debugger exceptions, which may be caused by a DTrace's FTB or PID probe firing, the system exception handler (*KiDispatchException*) checks whether the "trap" bit is set in the global *KiDynamicTraceMask* bitmask. If it is, the exception handler calls the *KiTpHandleTrap* function, which searches into the *KiTpHashTable* to determine whether the exception occurred thanks to a registered FTB or PID probe firing. For user-mode probes, the function checks whether the process context is the expected one. If it is, or if the probe is a kernel-mode one, the function directly invokes the DTrace callback, *FbtpCallback*, which executes the actions associated with the probe. When the callback completes, the handler invokes the emulator, which emulates the original first instruction of the target function before transferring the execution context to it.

EXPERIMENT: Tracing dynamic memory

In this experiment, you dynamically trace the dynamic memory applied to a VM. Using Hyper-V Manager, you need to create a generation 2 Virtual Machine and apply a minimum of 768 MB and an unlimited maximum amount of dynamic memory (more information on dynamic memory and Hyper-V is available in Chapter 9). The VM should have the May 2019 (19H1) or May 2020 (20H1) Update of Windows 10 or later installed as well as the DTrace package (which should be enabled as explained in the "Enabling DTrace and listing the installed providers" experiment from earlier in this chapter).

The `dynamic_memory.d` script, which can be found in this book's downloadable resources, needs to be copied in the DTrace directory and started by typing the following commands in an administrative command prompt window:

```
cd /d "c:\Program Files\DTrace"  
dtrace.exe -s dynamic_memory.d
```

With only the preceding commands, DTrace will refuse to compile the script because of an error similar to the following:

```
dtrace: failed to compile script dynamic_memory.d: line 62: probe description fbt:nt:MiRemovePhysicalMemory:entry does not match any probes
```

This is because, in standard configurations, the path of the symbols store is not set. The script attaches the FBT provider on two OS functions: *MmAddPhysicalMemory*, which is exported from the NT kernel binary, and *MiRemovePhysicalMemory*, which is not exported or published in the public WDK. For the latter, the FBT provider has no way to calculate its address in the system.

DTrace can obtain types and symbol information from different sources, as explained in the "DTrace type library" section later in this chapter. To allow the FBT provider to correctly work with internal OS functions, you should set the Symbol Store's path to point to the Microsoft public symbol server, using the following command:

```
set _NT_SYMBOL_PATH=srv*C:\symbols*http://msdl.microsoft.com/download/symbols
```

After the symbol store's path is set, if you restart DTrace targeting the `dynamic_memory.d` script, it should be able to correctly compile it and show the following output:

```
The Dynamic Memory script has begun.
```

Now you should simulate a high-memory pressure scenario. You can do this in multiple ways—for example, by starting your favorite browser and opening a lot of tabs, by starting a 3D game, or by simply using the `TestLimit` tool with the `-d` command switch, which forces the system to contiguously allocate memory and write to it until all the resources are exhausted. The VM worker process in the root partition should detect the scenario and inject new memory in the child VM. This would be detected by DTrace:

```
Physical memory addition request intercepted. Start physical address 0x00112C00, Number of pages: 0x00000400.  
Addition of 1024 memory pages starting at PFN 0x00112C00 succeeded!
```

In a similar way, if you close all the applications in the guest VM and you recreate a high-memory pressure scenario in your host system, the script would be able to intercept dynamic memory's removal requests:

```
Physical memory removal request intercepted. Start physical address 0x00132000, Number of pages: 0x00000200.  
Removal of 512 memory pages starting at PFN 0x00132000 succeeded!
```

After interrupting DTrace using **Ctrl+C**, the script prints out some statistics information:

```
Dynamic Memory script ended.  
Numbers of Hot Additions: 217  
Numbers of Hot Removals: 1602  
Since starts the system has gained 0x00017A00 pages (378 MB).
```

If you open the `dynamic_memory.d` script using Notepad, you will find that it installs a total of six probes (four FBT and two built-in) and performs logging and counting actions. For example,

```
fbt:nt:MmAddPhysicalMemory:return  
/ self->pStartingAddress != 0 /
```

installs a probe on the exit points of the `MmAddPhysicalMemory` function only if the starting physical address obtained at function entry point is not 0. More information on the D programming language applied to DTrace is available in the *The illumos Dynamic Tracing Guide* book, which is freely accessible at <http://dtrace.org/guide/preface.html>.

The ETW provider

DTrace supports both an ETW provider, which allows probes to fire when certain ETW events are generated by particular providers, and the `etw_trace` action, which allows DTrace scripts to generate new customized `TraceLogging` ETW events. The `etw_trace` action is implemented in `LibDTrace`, which uses `TraceLogging` APIs to dynamically register a new ETW provider and generate events associated with it. More information on ETW has been presented in the “Event Tracing for Windows (ETW)” section previously in this chapter.

The ETW provider is implemented in the DTrace driver. When the Trace engine is initialized by the Pnp manager, it registers all providers with the DTrace engine. At registration time, the ETW provider configures an ETW session called `DTraceLoggingSession`, which is set to write events in a circular buffer. When DTrace is started from the command line, it sends an IOCTL to DTrace driver. The IOCTL handler calls the `provide` function of each provider; the `DtEtwCreate` internal function invokes the `NtTraceControl` API with the `EtwEnumTraceGuidList` function code. This allows DTrace to enumerate all the ETW providers registered in the system and to create a probe for each of them. (`dtrace -l` is also able to display ETW probes.)

When a D script targeting the ETW provider is compiled and executed, the internal `DtEtwEnable` routine gets called with the goal of enabling one or more ETW probes. The logging session configured at registration time is started, if it's not already running. Through the trace extension context (which, as previously discussed, contains private system interfaces), DTrace is able to register a kernel-mode callback called every time a new event is logged in the DTrace logging session. The first time that the session is started, there are no providers associated with it. Similar to the syscall and FBT provider, for each probe DTrace creates a tracking data structure and inserts it in a global RB tree (`DtEtwProbeTree`) representing all the enabled ETW probes. The tracking data structure is important because it represents the link between the ETW provider and the probes associated with it. DTrace calculates the correct enablement level and keyword bitmask for the provider (see the "Provider Enablement" section previously in this chapter for more details) and enables the provider in the session by invoking the `NtTraceControl` API.

When an event is generated, the ETW subsystem calls the callback routine, which searches into the global ETW probe tree the correct context data structure representing the probe. When found, DTrace can fire the probe (still using the internal `dtrace_probe` function) and execute all the actions associated with it.

DTrace type library

DTrace works with types. System administrators are able to inspect internal operating system data structures and use them in D clauses to describe actions associated with probes. DTrace also supports supplemental data types compared to the ones supported by the standard D programming language. To be able to work with complex OS-dependent data types and allow the FBT and PID providers to set probes on internal OS and application functions, DTrace obtains information from different sources:

- Function names, signatures, and data types are initially extracted from information embedded in the executable binary (which adheres to the Portable Executable file format), like from the export table and debug information.
- For the original DTrace project, the Solaris operating system included support for Compact C Type Format (CTF) in its executable binary files (which adhere to the Executable and Linkable Format - ELF). This allowed the OS to store the debug information needed by DTrace to run directly into its modules (the debug information can also be stored using the deflate compression format). The Windows version of DTrace still supports a partial CTF, which has been added as a resource section of the LibDTrace library (`Dtrace.dll`). CTF in the LibDTrace library stores the type

information contained in the public WDK (Windows Driver Kit) and SDK (Software Development Kit) and allows DTrace to work with basic OS data types without requiring any symbol file.

- Most of the private types and internal OS function signatures are obtained from PDB symbols. Public PDB symbols for the majority of the operating system's modules are downloadable from the Microsoft Symbol Server. (These symbols are the same as those used by the Windows Debugger.) The symbols are deeply used by the FBT provider to correctly identify internal OS functions and by DTrace to be able to retrieve the correct type of parameters for each syscall and function.

The DTrace symbol server

DTrace includes an autonomous symbol server that can download PDB symbols from the Microsoft public Symbol store and render them available to the DTrace subsystem. The symbol server is implemented mainly in LibDTrace and can be queried by the DTrace driver using the Inverted call model. As part of the providers' registration, the DTrace driver registers a *SymServer* pseudo-provider. The latter is not a real provider but just a shortcut for allowing the *symsrv* handler to the DTrace control device to be registered.

When DTrace is started from the command line, the LibDTrace library starts the symbols server by opening a handle to the `\\.\dtrace\symsrv` control device (using the standard *CreateFile* API). The request is processed by the DTrace driver through the Symbol server IRP handler, which registers the user-mode process, adding it in an internal list of symbols server processes. LibDTrace then starts a new thread, which sends a dummy IOCTL to the DTrace symbol server device and waits indefinitely for a reply from the driver. The driver marks the IRP as pending and completes it only when a provider (or the DTrace subsystem), requires new symbols to be parsed.

Every time the driver completes the pending IRP, the DTrace symbols server thread wakes up and uses services exposed by the Windows Image Helper library (*Dbghelp.dll*) to correctly download and parse the required symbol. The driver then waits for a new dummy IOCTL to be sent from the symbols thread. This time the new IOCTL will contain the results of the symbol parsing process. The user-mode thread wakes up again only when the DTrace driver requires it.

Windows Error Reporting (WER)

Windows Error Reporting (WER) is a sophisticated mechanism that automates the submission of both user-mode process crashes as well as kernel-mode system crashes. Multiple system components have been designed for supporting reports generated when a user-mode process, protected process, trustlet, or the kernel crashes.

Windows 10, unlike from its predecessors, does not include a graphical dialog box in which the user can configure the details that Windows Error Reporting acquires and sends to Microsoft (or to an internal server configured by the system administrator) when an application crashes. As shown in Figure 10-38, in Windows 10, the Security and Maintenance applet of the Control Panel can show the user a history of the reports generated by Windows Error Reporting when an application (or the kernel) crashes. The applet can show also some basic information contained in the report.

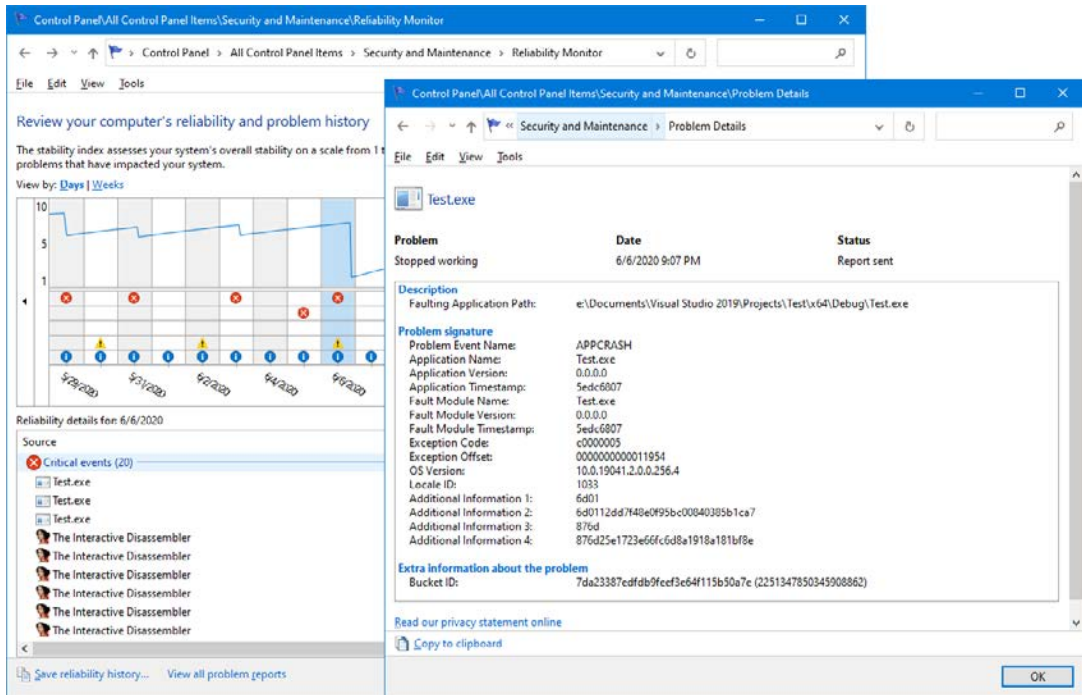

FIGURE 10-38 The Reliability monitor of the Security and Maintenance applet of the Control Panel.

Windows Error Reporting is implemented in multiple components of the OS, mainly because it needs to deal with different kind of crashes:

- The Windows Error Reporting Service (WerSvc.dll) is the main service that manages the creation and sending of reports when a user-mode process, protected process, or trustlet crashes.
- The Windows Fault Reporting and Secure Fault Reporting (WerFault.exe and WerFaultSecure.exe) are mainly used to acquire a snapshot of the crashing application and start the generation and sending of a report to the Microsoft Online Crash Analysis site (or, if configured, to an internal error reporting server).
- The actual generation and transmission of the report is performed by the Windows Error Reporting DLL (Wer.dll). The library includes all the functions used internally by the WER engine and also some exported API that the applications can use to interact with Windows Error Reporting (documented at https://docs.microsoft.com/en-us/windows/win32/api_wer/). Note that some WER APIs are also implemented in Kernelbase.dll and Faultrep.dll.
- The Windows User Mode Crash Reporting DLL (Faultrep.dll) contains common WER stub code that is used by system modules (Kernel32.dll, WER service, and so on) when a user-mode application crashes or hangs. It includes services for creating a crash signature and reports a hang to the WER service, managing the correct security context for the report creation and transmission (which includes the creation of the WerFault executable under the correct security token).

- The Windows Error Reporting Dump Encoding Library (Werenc.dll) is used by the Secure Fault Reporting to encrypt the dump files generated when a trustlet crashes.
- The Windows Error Reporting Kernel Driver (WerKernel.sys) is a kernel library that exports functions to capture a live kernel memory dump and submit the report to the Microsoft Online Crash Analysis site. Furthermore, the driver includes APIs for creating and submitting reports for user-mode faults from a kernel-mode driver.

Describing the entire architecture of WER is outside the scope of this book. In this section, we mainly describe error reporting for user-mode applications and the NT kernel (or kernel-driver) crashes.

User applications crashes

As discussed in Chapter 3 of Part 1, all the user-mode threads in Windows start with the *RtlUserThreadStart* function located in Ntdll. The function does nothing more than calling the real thread start routine under a structured exception handler. (Structured exception handling is described in Chapter 8.) The handler protecting the real start routine is internally called Unhandled Exception Handler because it is the last one that can manage an exception happening in a user-mode thread (when the thread does not already handle it). The handler, if executed, usually terminates the process with the *NtTerminateProcess* API. The entity that decides whether to execute the handler is the unhandled exception filter, *RtlpThreadExceptionFilter*. Noteworthy is that the unhandled exception filter and handler are executed only under abnormal conditions; normally, applications should manage their own exceptions with inner exception handlers.

When a Win32 process is starting, the Windows loader maps the needed imported libraries. The kernelbase initialization routine installs its own unhandled exception filter for the process, the *UnhandledExceptionFilter* routine. When a fatal unhandled exception happens in a process's thread, the filter is called to determine how to process the exception. The kernelbase unhandled exception filter builds context information (such as the current value of the machine's registers and stack, the faulting process ID, and thread ID) and processes the exception:

- If a debugger is attached to the process, the filter lets the exception happen (by returning *CONTINUE_SEARCH*). In this way, the debugger can break and see the exception.
- If the process is a trustlet, the filter stops any processing and invokes the kernel to start the Secure Fault Reporting (WerFaultSecure.exe).
- The filter calls the CRT unhandled exception routine (if it exists) and, in case the latter does not know how to handle the exception, it calls the internal *WerpReportFault* function, which connects to the WER service.

Before opening the ALPC connection, *WerpReportFault* should wake up the WER service and prepare an inheritable shared memory section, where it stores all the context information previously acquired. The WER service is a direct triggered-start service, which is started by the SCM only in case the *WER_SERVICE_START WNF* state is updated or in case an event is written in a dummy WER activation ETW provider (named Microsoft-Windows-Feedback-Service-Triggerprovider). *WerpReportFault*

updates the relative WNF state and waits on the `\KernelObjects\SystemErrorPortReady` event, which is signaled by the WER service to indicate that it is ready to accept new connections. After a connection has been established, Ntdll connects to the WER service's `\WindowsErrorReportingServicePort` ALPC port, sends the `WERSVC_REPORT_CRASH` message, and waits indefinitely for its reply.

The message allows the WER service to begin to analyze the crashed program's state and performs the appropriate actions to create a crash report. In most cases, this means launching the `WerFault.exe` program. For user-mode crashes, the Windows Fault Reporting process is invoked two times using the faulting process's credentials. The first time is used to acquire a "snapshot" of the crashing process. This feature was introduced in Windows 8.1 with the goal of rendering the crash report generation of UWP applications (which, at that time, were all single-instance applications) faster. In that way, the user could have restarted a crashed UWP application without waiting for the report being generated. (UWP and the modern application stack are discussed in Chapter 8.)

Snapshot creation

WerFault maps the shared memory section containing the crash data and opens the faulting process and thread. When invoked with the `-pss` command-line argument (used for requesting a process snapshot), it calls the `PssNtCaptureSnapshot` function exported by Ntdll. The latter uses native APIs to query multiple information regarding the crashing process (like basic information, job information, process times, secure mitigations, process file name, and shared user data section). Furthermore, the function queries information regarding all the memory sections baked by a file and mapped in the entire user-mode address space of the process. It then saves all the acquired data in a `PSS_SNAPSHOT` data structure representing a snapshot. It finally creates an identical copy of the entire VA space of the crashing process into another dummy process (cloned process) using the `NtCreateProcessEx` API (providing a special combination of flags). From now on, the original process can be terminated, and further operations needed for the report can be executed on the cloned process.



Note WER does not perform any snapshot creation for protected processes and trustlets. In these cases, the report is generated by obtaining data from the original faulting process, which is suspended and resumed only after the report is completed.

Crash report generation

After the snapshot is created, execution control returns to the WER service, which initializes the environment for the crash report creation. This is done mainly in two ways:

- If the crash happened to a normal, unprotected process, the WER service directly invokes the `WerpInitiateCrashReporting` routine exported from the Windows User Mode Crash Reporting DLL (`Faultrep.dll`).
- Crashes belonging to protected processes need another broker process, which is spawned under the `SYSTEM` account (and not the faulting process credentials). The broker performs some verifications and calls the same routine used for crashes happening in normal processes.

The *WerplnitiatCrashReporting* routine, when called from the WER service, prepares the environment for executing the correct Fault Reporting process. It uses APIs exported from the WER library to initialize the machine store (which, in its default configuration, is located in C:\ProgramData\Microsoft\Windows\WER) and load all the WER settings from the Windows registry. WER indeed contains many customizable options that can be configured by the user through the Group Policy editor or by manually making changes to the registry. At this stage, WER impersonates the user that has started the faulting application and starts the correct Fault Reporting process using the -u main command-line switch, which indicates to the WerFault (or WerFaultSecure) to process the user crash and create a new report.



Note If the crashing process is a Modern application running under a low-integrity level or AppContainer token, WER uses the User Manager service to generate a new medium-IL token representing the user that has launched the faulting application.

Table 10-19 lists the WER registry configuration options, their use, and possible values. These values are located under the HKLM\SOFTWARE\Microsoft\Windows\Windows Error Reporting subkey for computer configuration and in the equivalent path under HKEY_CURRENT_USER for per-user configuration (some values can also be present in the \Software\Policies\Microsoft\Windows\Windows Error Reporting key).

TABLE 10-19 WER registry settings

Settings	Meaning	Values
<i>ConfigureArchive</i>	Contents of archived data	1 for parameters, 2 for all data
<i>Consent\DefaultConsent</i>	What kind of data should require consent	1 for any data, 2 for parameters only, 3 for parameters and safe data, 4 for all data.
<i>Consent\DefaultOverrideBehavior</i>	Whether the <i>DefaultConsent</i> overrides WER plug-in consent values	1 to enable override
<i>Consent\PluginName</i>	Consent value for a specific WER plug-in	Same as <i>DefaultConsent</i>
<i>CorporateWERDirectory</i>	Directory for a corporate WER store	String containing the path
<i>CorporateWERPortNumber</i>	Port to use for a corporate WER store	Port number
<i>CorporateWERServer</i>	Name to use for a corporate WER store	String containing the name
<i>CorporateWERUseAuthentication</i>	Use Windows Integrated Authentication for corporate WER store	1 to enable built-in authentication
<i>CorporateWERUseSSL</i>	Use Secure Sockets Layer (SSL) for corporate WER store	1 to enable SSL
<i>DebugApplications</i>	List of applications that require the user to choose between Debug and Continue	1 to require the user to choose
<i>DisableArchive</i>	Whether the archive is enabled	1 to disable archive
<i>Disabled</i>	Whether WER is disabled	1 to disable WER
<i>DisableQueue</i>	Determines whether reports are to be queued	1 to disable queue
<i>DontShowUI</i>	Disables or enables the WER UI	1 to disable UI

Settings	Meaning	Values
<i>DontSendAdditionalData</i>	Prevents additional crash data from being sent	1 not to send
<i>ExcludedApplications\AppDataName</i>	List of applications excluded from WER	String containing the application list
<i>ForceQueue</i>	Whether reports should be sent to the user queue	1 to send reports to the queue
<i>LocalDumps\DumpFolder</i>	Path at which to store the dump files	String containing the path
<i>LocalDumps\DumpCount</i>	Maximum number of dump files in the path	Count
<i>LocalDumps\DumpType</i>	Type of dump to generate during a crash	0 for a custom dump, 1 for a minidump, 2 for a full dump
<i>LocalDumps\CustomDumpFlags</i>	For custom dumps, specifies custom options	Values defined in <i>MINIDUMP_TYPE</i> (see Chapter 12 for more information)
<i>LoggingDisabled</i>	Enables or disables logging	1 to disable logging
<i>MaxArchiveCount</i>	Maximum size of the archive (in files)	Value between 1–5000
<i>MaxQueueCount</i>	Maximum size of the queue	Value between 1–500
<i>QueuePesterInterval</i>	Days between requests to have the user check for solutions	Number of days

The Windows Fault Reporting process started with the `-u` switch starts the report generation: the process maps again the shared memory section containing the crash data, identifies the exception's record and descriptor, and obtains the snapshot taken previously. In case the snapshot does not exist, the WerFault process operates directly on the faulting process, which is suspended. WerFault first determines the nature of the faulting process (service, native, standard, or shell process). If the faulting process has asked the system not to report any hard errors (through the *SetErrorMode* API), the entire process is aborted, and no report is created. Otherwise, WER checks whether a default post-mortem debugger is enabled through settings stored in the *AeDebug* subkey (*AeDebugProtected* for protected processes) under the `HKLM\SOFTWARE\Microsoft\Windows NT\CurrentVersion\` root registry key. Table 10-20 describes the possible values of both keys.

TABLE 10-20 Valid registry values used for the *AeDebug* and *AeDebugProtected* root keys

Value name	Meaning	Data
<i>Debugger</i>	Specify the debugger executable to be launched when an application crashes.	Full path of the debugger executable, with eventual command-line arguments. The <code>-p</code> switch is automatically added by WER, pointing it to the crashing process ID.
<i>ProtectedDebugger</i>	Same as <i>Debugger</i> but for protected processes only.	Full path of the debugger executable. Not valid for the <i>AeDebug</i> key.
<i>Auto</i>	Specify the Autostartup mode	1 to enable the launching of the debugger in any case, without any user consent, 0 otherwise.
<i>LaunchNonProtected</i>	Specify whether the debugger should be executed as unprotected. This setting applies only to the <i>AeDebugProtected</i> key.	1 to launch the debugger as a standard process.

If the debugger start type is set to Auto, WER starts it and waits for a debugger event to be signaled before continuing the report creation. The report generation is started through the internal *GenerateCrashReport* routine implemented in the User Mode Crash Reporting DLL (Faultrep.dll). The latter configures all the WER plug-ins and initializes the report using the *WerReportCreate* API, exported from the WER.dll. (Note that at this stage, the report is only located in memory.) The *GenerateCrashReport* routine calculates the report ID and a signature and adds further diagnostics data to the report, like the process times and startup parameters or application-defined data. It then checks the WER configuration to determine which kind of memory dump to create (by default, a minidump is acquired). It then calls the exported *WerReportAddDump* API with the goal to initialize the dump acquisition for the faulting process (it will be added to the final report). Note that if a snapshot has been previously acquired, it is used for acquiring the dump.

The *WerReportSubmit* API, exported from WER.dll, is the central routine that generates the dump of the faulting process, creates all the files included in the report, shows the UI (if configured to do so by the *DontShowUI* registry value), and sends the report to the Online Crash server. The report usually includes the following:

- A minidump file of the crashing process (usually named memory.hdmp)
- A human-readable text report, which includes exception information, the calculated signature of the crash, OS information, a list of all the files associated with the report, and a list of all the modules loaded in the crashing process (this file is usually named report.wer)
- A CSV (comma separated values) file containing a list of all the active processes at the time of the crash and basic information (like the number of threads, the private working set size, hard fault count, and so on)
- A text file containing the global memory status information
- A text file containing application compatibility information

The Fault Reporting process communicates through ALPC to the WER service and sends commands to allow the service to generate most of the information present in the report. After all the files have been generated, if configured appropriately, the Windows Fault Reporting process presents a dialog box (as shown in Figure 10-39) to the user, notifying that a critical error has occurred in the target process. (This feature is disabled by default in Windows 10.)

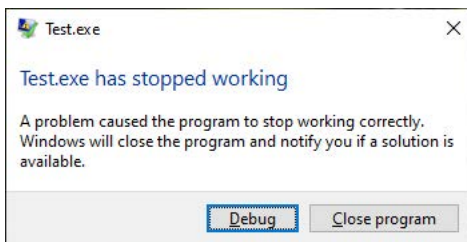

FIGURE 10-39 The Windows Error Reporting dialog box.

In environments where systems are not connected to the Internet or where the administrator wants to control which error reports are submitted to Microsoft, the destination for the error report can be configured to be an internal file server. The System Center Desktop Error Monitoring (part of the Microsoft Desktop Optimization Pack) understands the directory structure created by Windows Error Reporting and provides the administrator with the option to take selective error reports and submit them to Microsoft.

As previously discussed, the WER service uses an ALPC port for communicating with crashed processes. This mechanism uses a systemwide error port that the WER service registers through *NtSetInformationProcess* (which uses *DbgkRegisterErrorPort*). As a result, all Windows processes have an error port that is actually an ALPC port object registered by the WER service. The kernel and the unhandled exception filter in *Ntdll* use this port to send a message to the WER service, which then analyzes the crashing process. This means that even in severe cases of thread state damage, WER is still able to receive notifications and launch *WerFault.exe* to log the detailed information of the critical error in a Windows Event log (or to display a user interface to the user) instead of having to do this work within the crashing thread itself. This solves all the problems of silent process death: Users are notified, debugging can occur, and service administrators can see the crash event.

EXPERIMENT: Enabling the WER user interface

Starting with the initial release of Windows 10, the user interface displayed by WER when an application crashes has been disabled by default. This is primarily because of the introduction of the Restart Manager (part of the Application Recovery and Restart technology). The latter allows applications to register a restart or recovery callback invoked when an application crashes, hangs, or just needs to be restarted for servicing an update. As a result, classic applications that do not register any recovery callback when they encounter an unhandled exception just terminate without displaying any message to the user (but correctly logging the error in the system log). As discussed in this section, WER supports a user interface, which can be enabled by just adding a value in one of the WER keys used for storing settings. For this experiment, you will re-enable the WER UI using the global system key.

From the book's downloadable resources, copy the *BuggedApp* executable and run it. After pressing a key, the application generates a critical unhandled exception that WER intercepts and reports. In default configurations, no error message is displayed. The process is terminated, an error event is stored in the system log, and the report is generated and sent without any user intervention. Open the Registry Editor (by typing **regedit** in the Cortana search box) and navigate to the `HKLM\SOFTWARE\Microsoft\Windows\Windows Error Reporting` registry key. If the *DontShowUI* value does not exist, create it by right-clicking the root key and selecting **New, DWORD (32 bit) Value** and assign 0 to it.

If you restart the bugged application and press a key, WER displays a user interface similar to the one shown in Figure 10-39 before terminating the crashing application. You can repeat the experiment by adding a debugger to the *AeDebug* key. Running *Windbg* with the **-I** switch performs the registration automatically, as discussed in the "Witnessing a COM-hosted task" experiment earlier in this chapter.

Kernel-mode (system) crashes

Before discussing how WER is involved when a kernel crashes, we need to introduce how the kernel records crash information. By default, all Windows systems are configured to attempt to record information about the state of the system before the Blue Screen of Death (BSOD) is displayed, and the system is restarted. You can see these settings by opening the **System Properties** tool in **Control Panel** (under **System and Security, System, Advanced System Settings**), clicking the **Advanced** tab, and then clicking the **Settings** button under Startup and Recovery. The default settings for a Windows system are shown in Figure 10-40.

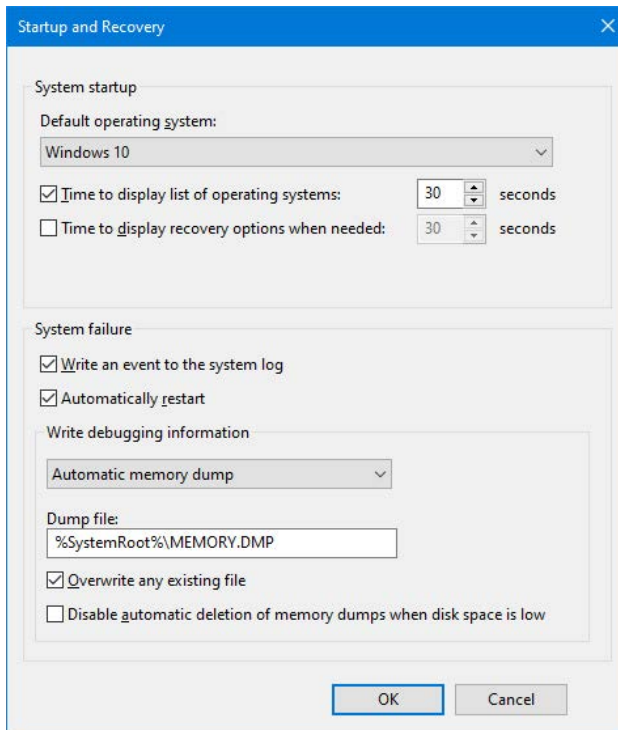

FIGURE 10-40 Crash dump settings.

Crash dump files

Different levels of information can be recorded on a system crash:

- **Active memory dump** An active memory dump contains all physical memory accessible and in use by Windows at the time of the crash. This type of dump is a subset of the complete memory dump; it just filters out pages that are not relevant for troubleshooting problems on the host machine. This dump type includes memory allocated to user-mode applications and active pages mapped into the kernel or user space, as well as selected Pagefile-backed Transition, Standby, and Modified pages such as the memory allocated with *VirtualAlloc* or page-file backed sections. Active dumps do not include pages on the free and zeroed lists, the file cache, guest VM pages, and various other types of memory that are not useful during debugging.

- **Complete memory dump** A complete memory dump is the largest kernel-mode dump file that contains all the physical pages accessible by Windows. This type of dump is not fully supported on all platforms (the active memory dump superseded it). Windows requires that a page file be at least the size of physical memory plus 1 MB for the header. Device drivers can add up to 256 MB for secondary crash dump data, so to be safe, it's recommended that you increase the size of the page file by an additional 256 MB.
- **Kernel memory dump** A kernel memory dump includes only the kernel-mode pages allocated by the operating system, the HAL, and device drivers that are present in physical memory at the time of the crash. This type of dump does not contain pages belonging to user processes. Because only kernel-mode code can directly cause Windows to crash, however, it's unlikely that user process pages are necessary to debug a crash. In addition, all data structures relevant for crash dump analysis—including the list of running processes, the kernel-mode stack of the current thread, and list of loaded drivers—are stored in nonpaged memory that saves in a kernel memory dump. There is no way to predict the size of a kernel memory dump because its size depends on the amount of kernel-mode memory allocated by the operating system and drivers present on the machine.
- **Automatic memory dump** This is the default setting for both Windows client and server systems. An automatic memory dump is similar to a kernel memory dump, but it also saves some metadata of the active user-mode process (at the time of the crash). Furthermore, this dump type allows better management of the system paging file's size. Windows can set the size of the paging file to less than the size of RAM but large enough to ensure that a kernel memory dump can be captured most of the time.
- **Small memory dump** A small memory dump, which is typically between 128 KB and 1 MB in size and is also called a minidump or triage dump, contains the stop code and parameters, the list of loaded device drivers, the data structures that describe the current process and thread (called the EPROCESS and ETHREAD—described in Chapter 3 of Part 1), the kernel stack for the thread that caused the crash, and additional memory considered potentially relevant by crash dump heuristics, such as the pages referenced by processor registers that contain memory addresses and secondary dump data added by drivers.



Note Device drivers can register a secondary dump data callback routine by calling *KeRegisterBugCheckReasonCallback*. The kernel invokes these callbacks after a crash and a callback routine can add additional data to a crash dump file, such as device hardware memory or device information for easier debugging. Up to 256 MB can be added systemwide by all drivers, depending on the space required to store the dump and the size of the file into which the dump is written, and each callback can add at most one-eighth of the available additional space. Once the additional space is consumed, drivers subsequently called are not offered the chance to add data.

The debugger indicates that it has limited information available to it when it loads a minidump, and basic commands like `!process`, which lists active processes, don't have the data they need. A kernel

memory dump includes more information, but switching to a different process's address space mappings won't work because required data isn't in the dump file. While a complete memory dump is a superset of the other options, it has the drawback that its size tracks the amount of physical memory on a system and can therefore become unwieldy. Even though user-mode code and data usually are not used during the analysis of most crashes, the active memory dump overcame the limitation by storing in the dump only the memory that is actually used (excluding physical pages in the free and zeroed list). As a result, it is possible to switch address space in an active memory dump.

An advantage of a minidump is its small size, which makes it convenient for exchange via email, for example. In addition, each crash generates a file in the directory %SystemRoot%\Minidump with a unique file name consisting of the date, the number of milliseconds that have elapsed since the system was started, and a sequence number (for example, 040712-24835-01.dmp). If there's a conflict, the system attempts to create additional unique file names by calling the Windows *GetTickCount* function to return an updated system tick count, and it also increments the sequence number. By default, Windows saves the last 50 minidumps. The number of minidumps saved is configurable by modifying the *MinidumpsCount* value under the HKLM\SYSTEM\CurrentControlSet\Control\CrashControl registry key.

A significant disadvantage is that the limited amount of data stored in the dump can hamper effective analysis. You can also get the advantages of minidumps even when you configure a system to generate kernel, complete, active, or automatic crash dumps by opening the larger crash with WinDbg and using the **.dump /m** command to extract a minidump. Note that a minidump is automatically created even if the system is set for full or kernel dumps.



Note You can use the **.dump** command from within LiveKd to generate a memory image of a live system that you can analyze offline without stopping the system. This approach is useful when a system is exhibiting a problem but is still delivering services, and you want to troubleshoot the problem without interrupting service. To prevent creating crash images that aren't necessarily fully consistent because the contents of different regions of memory reflect different points in time, LiveKd supports the **-m** flag. The mirror dump option produces a consistent snapshot of kernel-mode memory by leveraging the memory manager's memory mirroring APIs, which give a point-in-time view of the system.

The kernel memory dump option offers a practical middle ground. Because it contains all kernel-mode-owned physical memory, it has the same level of analysis-related data as a complete memory dump, but it omits the usually irrelevant user-mode data and code, and therefore can be significantly smaller. As an example, on a system running a 64-bit version of Windows with 4 GB of RAM, a kernel memory dump was 294 MB in size.

When you configure kernel memory dumps, the system checks whether the paging file is large enough, as described earlier. There isn't a reliable way to predict the size of a kernel memory dump. The reason you can't predict the size of a kernel memory dump is that its size depends on the amount of kernel-mode memory in use by the operating system and drivers present on the machine at the time of the crash. Therefore, it is possible that at the time of the crash, the paging file is too small to hold a

kernel dump, in which case the system will switch to generating a minidump. If you want to see the size of a kernel dump on your system, force a manual crash either by configuring the registry option to allow you to initiate a manual system crash from the console (documented at <https://docs.microsoft.com/en-us/windows-hardware/drivers/debugger/forcing-a-system-crash-from-the-keyboard>) or by using the Notmyfault tool (<https://docs.microsoft.com/en-us/sysinternals/downloads/notmyfault>).

The automatic memory dump overcomes this limitation, though. The system will be indeed able to create a paging file large enough to ensure that a kernel memory dump can be captured most of the time. If the computer crashes and the paging file is not large enough to capture a kernel memory dump, Windows increases the size of the paging file to at least the size of the physical RAM installed.

To limit the amount of disk space that is taken up by crash dumps, Windows needs to determine whether it should maintain a copy of the last kernel or complete dump. After reporting the kernel fault (described later), Windows uses the following algorithm to decide whether it should keep the Memory.dmp file. If the system is a server, Windows always stores the dump file. On a Windows client system, only domain-joined machines will always store a crash dump by default. For a non-domain-joined machine, Windows maintains a copy of the crash dump only if there is more than 25 GB of free disk space on the destination volume (4 GB on ARM64, configurable via the HKLM\SYSTEM\CurrentControlSet\Control\CrashControl\PersistDumpDiskSpaceLimit registry value)—that is, the volume where the system is configured to write the Memory.dmp file. If the system, due to disk space constraints, is unable to keep a copy of the crash dump file, an event is written to the System event log indicating that the dump file was deleted, as shown in Figure 10-41. This behavior can be overridden by creating the DWORD registry value HKLM\SYSTEM\CurrentControlSet\Control\CrashControl\AlwaysKeepMemoryDump and setting it to 1, in which case Windows always keeps a crash dump, regardless of the amount of free disk space.

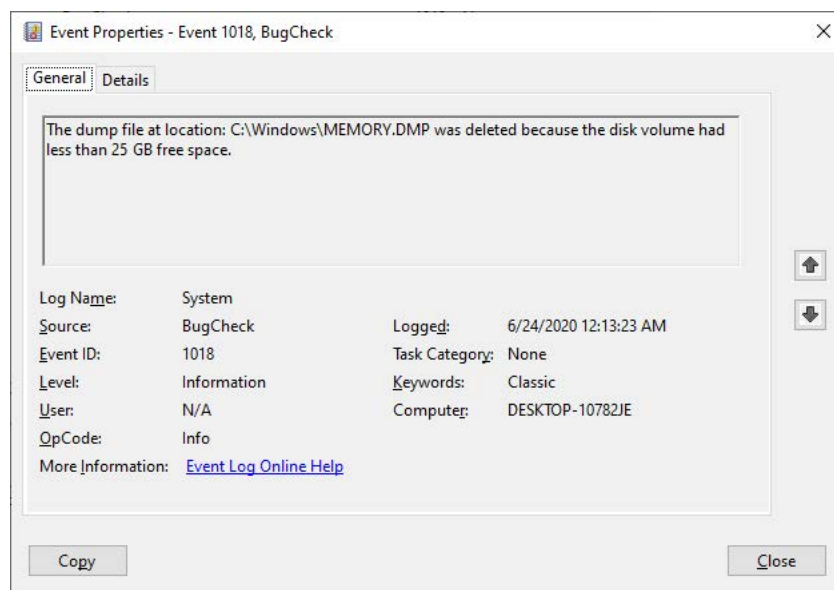

FIGURE 10-41 Dump file deletion event log entry.

EXPERIMENT: Viewing dump file information

Each crash dump file contains a dump header that describes the stop code and its parameters, the type of system the crash occurred on (including version information), and a list of pointers to important kernel-mode structures required during analysis. The dump header also contains the type of crash dump that was written and any information specific to that type of dump. The **.dumpdebug** debugger command can be used to display the dump header of a crash dump file. For example, the following output is from a crash of a system that was configured for an automatic dump:

```
0: kd> .dumpdebug
----- 64 bit Kernel Bitmap Dump Analysis - Kernel address space is available,
        User address space may not be available.
```

```
DUMP_HEADER64:
MajorVersion      0000000f
MinorVersion      000047ba
KdSecondaryVersion 00000002
DirectoryTableBase 00000000`006d4000
PfnDataBase       fffffe980`00000000
PsLoadedModuleList fffff800`5df00170
PsActiveProcessHead fffff800`5def0b60
MachineImageType  00008664
NumberProcessors  00000003
BugCheckCode      000000e2
BugCheckParameter1 00000000`00000000
BugCheckParameter2 00000000`00000000
BugCheckParameter3 00000000`00000000
BugCheckParameter4 00000000`00000000
KdDebuggerDataBlock fffff800`5dede5e0
SecondaryDataState 00000000
ProductType       00000001
SuiteMask         00000110
Attributes        00000000
```

```
BITMAP_DUMP:
DumpOptions       00000000
HeaderSize        16000
BitmapSize        9ba00
Pages             25dee
```

```
KiProcessorBlock at fffff800`5e02dac0
  3 KiProcessorBlock entries:
  fffff800`5c32f180 fffff801`9f703180 fffff801`9f3a0180
```

The **.enumtag** command displays all secondary dump data stored within a crash dump (as shown below). For each callback of secondary data, the tag, the length of the data, and the data itself (in byte and ASCII format) are displayed. Developers can use Debugger Extension APIs to create custom debugger extensions to also read secondary dump data. (See the “Debugging Tools for Windows” help file for more information.)

```
{E83B40D2-B0A0-4842-ABEA71C9E3463DD1} - 0x100 bytes
46 41 43 50 14 01 00 00 06 98 56 52 54 55 41 4C  FACP.....VIRTUAL
4D 49 43 52 4F 53 46 54 01 00 00 00 4D 53 46 54  MICROSOFT...MSFT
53 52 41 54 A0 01 00 00 02 C6 56 52 54 55 41 4C  SRAT.....VIRTUAL
4D 49 43 52 4F 53 46 54 01 00 00 00 4D 53 46 54  MICROSOFT...MSFT
57 41 45 54 28 00 00 00 01 22 56 52 54 55 41 4C  WAET(..."VIRTUAL
4D 49 43 52 4F 53 46 54 01 00 00 00 4D 53 46 54  MICROSOFT...MSFT
41 50 49 43 60 00 00 00 04 F7 56 52 54 55 41 4C  APIC`.....VIRTUAL
...
```

Crash dump generation

Phase 1 of the system boot process allows the I/O manager to check the configured crash dump options by reading the HKLM\SYSTEM\CurrentControlSet\Control\CrashControl registry key. If a dump is configured, the I/O manager loads the crash dump driver (Crashdmp.sys) and calls its entry point. The entry point transfers back to the I/O manager a table of control functions, which are used by the I/O manager for interacting with the crash dump driver. The I/O manager also initializes the secure encryption needed by the Secure Kernel to store the encrypted pages in the dump. One of the control functions in the table initializes the global crash dump system. It gets the physical sectors (file extent) where the page file is stored and the volume device object associated with it.

The global crash dump initialization function obtains the miniport driver that manages the physical disk in which the page file is stored. It then uses the *MmLoadSystemImageEx* routine to make a copy of the crash dump driver and the disk miniport driver, giving them their original names prefixed by the *dump_* string. Note that this implies also creating a copy of all the drivers imported by the miniport driver, as shown in the Figure 10-42.

```
Command - Kernel 'net:port=54005,key=*****' - WinD...
0: kd> lm m dump*
Browse full module list
start          end                module name
fffff802`798e0000 fffff802`79910000 dump_vmbus (deferred)
fffff802`79920000 fffff802`79948000 dump_hvsocket (deferred)
fffff802`79950000 fffff802`799e4000 dump_NETIO (deferred)
fffff802`79a00000 fffff802`79a10000 dump_WppRecorder (deferred)
fffff802`79a20000 fffff802`79adc000 dump_cng (deferred)
fffff802`79ae0000 fffff802`79b40000 dump_msrpc (deferred)
fffff802`79b50000 fffff802`79b62000 dump_winhiv (deferred)
fffff802`79b70000 fffff802`79b83000 dump_WDFLDR (deferred)
fffff802`7a680000 fffff802`7a7f2000 dump_NDIS (deferred)
fffff802`7b470000 fffff802`7b47e000 dump_diskdump (deferred)
fffff802`7b490000 fffff802`7b49f000 dump_storvsc (deferred)
fffff802`7b4a0000 fffff802`7b4bd000 dump_vmbkmcl (deferred)
fffff802`7b4e0000 fffff802`7b4fd000 dump_dumpfve (deferred)
0: kd>
```

FIGURE 10-42 Kernel modules copied for use to generate and write a crash dump file.

The system also queries the `DumpFilters` value for any filter drivers that are required for writing to the volume, an example being `Dumpfve.sys`, the BitLocker Drive Encryption Crashdump Filter driver. It also collects information related to the components involved with writing a crash dump—including the name of the disk miniport driver, the I/O manager structures that are necessary to write the dump, and the map of where the paging file is on disk—and saves two copies of the data in dump-context structures. The system is ready to generate and write a dump using a safe, noncorrupted path.

Indeed, when the system crashes, the crash dump driver (`%SystemRoot%\System32\Drivers\Crashdump.sys`) verifies the integrity of the two dump-context structures obtained at boot by performing a memory comparison. If there's not a match, it does not write a crash dump because doing so would likely fail or corrupt the disk. Upon a successful verification match, `Crashdump.sys`, with support from the copied disk miniport driver and any required filter drivers, writes the dump information directly to the sectors on disk occupied by the paging file, bypassing the file system driver and storage driver stack (which might be corrupted or even have caused the crash).



Note Because the page file is opened early during system startup for crash dump use, most crashes that are caused by bugs in system-start driver initialization result in a dump file. Crashes in early Windows boot components such as the HAL or the initialization of boot drivers occur too early for the system to have a page file, so using another computer to debug the startup process is the only way to perform crash analysis in those cases.

During the boot process, the Session Manager (`Smss.exe`) checks the registry value `HKLM\SYSTEM\CurrentControlSet\Control\Session Manager\Memory Management\ExistingPageFiles` for a list of existing page files from the previous boot. (See Chapter 5 of Part 1 for more information on page files.) It then cycles through the list, calling the function `SmpCheckForCrashDump` on each file present, looking to see whether it contains crash dump data. It checks by searching the header at the top of each paging file for the signature `PAGEDUMP` or `PAGEDU64` on 32-bit or 64-bit systems, respectively. (A match indicates that the paging file contains crash dump information.) If crash dump data is present, the Session Manager then reads a set of crash parameters from the `HKLM\SYSTEM\CurrentControlSet\Control\CrashControl` registry key, including the `DumpFile` value that contains the name of the target dump file (typically `%SystemRoot%\Memory.dmp`, unless configured otherwise).

`Smss.exe` then checks whether the target dump file is on a different volume than the paging file. If so, it checks whether the target volume has enough free disk space (the size required for the crash dump is stored in the dump header of the page file) before truncating the paging file to the size of the crash data and renaming it to a temporary dump file name. (A new page file will be created later when the Session Manager calls the `NtCreatePagingFile` function.) The temporary dump file name takes the format `DUMPxxxx.tmp`, where `xxxx` is the current low-word value of the system's tick count (The system attempts 100 times to find a nonconflicting value.) After renaming the page file, the system removes both the hidden and system attributes from the file and sets the appropriate security descriptors to secure the crash dump.

Next, the Session Manager creates the volatile registry key `HKLM\SYSTEM\CurrentControlSet\Control\CrashControl\MachineCrash` and stores the temporary dump file name in the value `DumpFile`.

It then writes a DWORD to the *TempDestination* value indicating whether the dump file location is only a temporary destination. If the paging file is on the same volume as the destination dump file, a temporary dump file isn't used because the paging file is truncated and directly renamed to the target dump file name. In this case, the *DumpFile* value will be that of the target dump file, and *TempDestination* will be 0.

Later in the boot, Wininit checks for the presence of the *MachineCrash* key, and if it exists, launches the Windows Fault Reporting process (*WerFault.exe*) with the **-k -c** command-line switches (the **k** flag indicates kernel error reporting, and the **c** flag indicates that the full or kernel dump should be converted to a minidump). *WerFault* reads the *TempDestination* and *DumpFile* values. If the *TempDestination* value is set to 1, which indicates a temporary file was used, *WerFault* moves the temporary file to its target location and secures the target file by allowing only the System account and the local Administrators group access. *WerFault* then writes the final dump file name to the *FinalDumpFileLocation* value in the *MachineCrash* key. These steps are shown in Figure 10-43.

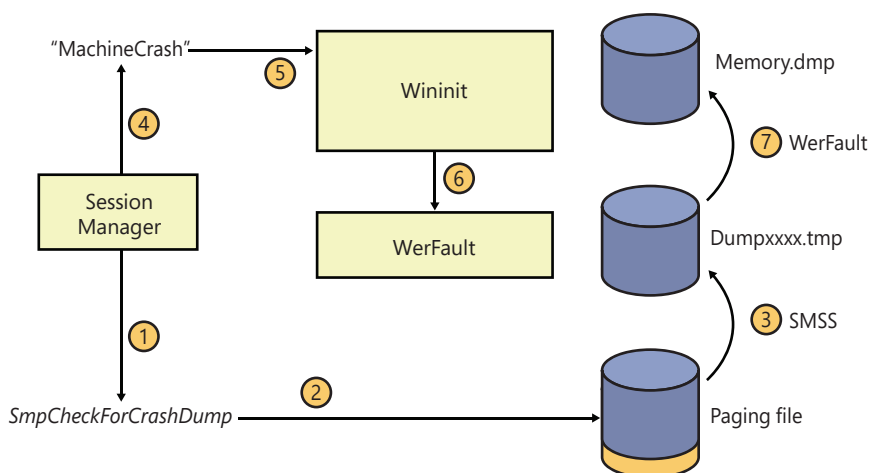

FIGURE 10-43 Crash dump file generation.

To provide more control over where the dump file data is written to—for example, on systems that boot from a SAN or systems with insufficient disk space on the volume where the paging file is configured—Windows also supports the use of a *dedicated dump file* that is configured in the *DedicatedDumpFile* and *DumpFileSize* values under the *HKLM\SYSTEM\CurrentControlSet\Control\CrashControl* registry key. When a dedicated dump file is specified, the crash dump driver creates the dump file of the specified size and writes the crash data there instead of to the paging file. If no *DumpFileSize* value is given, Windows creates a dedicated dump file using the largest file size that would be required to store a complete dump. Windows calculates the required size as the size of the total number of physical pages of memory present in the system plus the size required for the dump header (one page on 32-bit systems, and two pages on 64-bit systems), plus the maximum value for secondary crash dump data, which is 256 MB. If a full or kernel dump is configured but there is not enough space on the target volume to create the dedicated dump file of the required size, the system falls back to writing a minidump.

Kernel reports

After the WerFault process is started by Wininit and has correctly generated the final dump file, WerFault generates the report to send to the Microsoft Online Crash Analysis site (or, if configured, an internal error reporting server). Generating a report for a kernel crash is a procedure that involves the following:

1. If the type of dump generated was not a minidump, it extracts a minidump from the dump file and stores it in the default location of %SystemRoot%\Minidump, unless otherwise configured through the *MinidumpDir* value in the HKLM\SYSTEM\CurrentControlSet\Control\CrashControl key.
2. It writes the name of the minidump files to HKLM\SOFTWARE\Microsoft\Windows\Windows Error Reporting\KernelFaults\Queue.
3. It adds a command to execute WerFault.exe (%SystemRoot%\System32\WerFault.exe) with the **-k -rq** flags (the **rq** flag specifies to use queued reporting mode and that WerFault should be restarted) to HKLM\SOFTWARE\Microsoft\Windows\CurrentVersion\RunOnce so that WerFault is executed during the first user's logon to the system for purposes of actually sending the error report.

When the WerFault utility executes during logon, as a result of having configured itself to start, it launches itself again using the **-k -q** flags (the **q** flag on its own specifies queued reporting mode) and terminates the previous instance. It does this to prevent the Windows shell from waiting on WerFault by returning control to RunOnce as quickly as possible. The newly launched WerFault.exe checks the HKLM\SOFTWARE\Microsoft\Windows\Windows Error Reporting\KernelFaults\Queue key to look for queued reports that may have been added in the previous dump conversion phase. It also checks whether there are previously unsent crash reports from previous sessions. If there are, WerFault.exe generates two XML-formatted files:

- The first contains a basic description of the system, including the operating system version, a list of drivers installed on the machine, and the list of devices present in the system.
- The second contains metadata used by the OCA service, including the event type that triggered WER and additional configuration information, such as the system manufacturer.

WerFault then sends a copy of the two XML files and the minidump to Microsoft OCA server, which forwards the data to a server farm for automated analysis. The server farm's automated analysis uses the same analysis engine that the Microsoft kernel debuggers use when you load a crash dump file into them. The analysis generates a bucket ID, which is a signature that identifies a particular crash type.

Process hang detection

Windows Error reporting is also used when an application hangs and stops work because of some defect or bug in its code. An immediate effect of an application hanging is that it would not react to any user interaction. The algorithm used for detecting a hanging application depends on the application type: the Modern application stack detects that a Centennial or UWP application is hung when a request sent from the HAM (Host Activity Manager) is not processed after a well-defined timeout (usually 30 seconds); the Task manager detects a hung application when an application does not reply

to the *WM_QUIT* message; Win32 desktop applications are considered not responding and hung when a foreground window stops to process GDI messages for more than 5 seconds.

Describing all the hung detection algorithms is outside the scope of this book. Instead, we will consider the most likely case of a classical Win32 desktop application that stopped to respond to any user input. The detection starts in the Win32k kernel driver, which, after the 5-second timeout, sends a message to the DwmApiPort ALPC port created by the Desktop Windows Manager (DWM.exe). The DWM processes the message using a complex algorithm that ends up creating a “ghost” window on top of the hanging window. The ghost redraws the window’s original content, blurring it out and adding the (Not Responding) string in the title. The ghost window processes GDI messages through an internal message pump routine, which intercepts the close, exit, and activate messages by calling the *ReportHang* routine exported by the Windows User Mode Crash Reporting DLL (faultrep.dll). The *ReportHang* function simply builds a *WERSVC_REPORT_HANG* message and sends it to the WER service to wait for a reply.

The WER service processes the message and initializes the Hang reporting by reading settings values from the HKLM\Software\Microsoft\Windows\Windows Error Reporting\Hangs root registry key. In particular, the *MaxHangreplInstances* value is used to indicate how many hanging reports can be generated in the same time (the default number is eight if the value does not exist), while the *TerminationTimeout* value specifies the time that needs to pass after WER has tried to terminate the hanging process before considering the entire system to be in hanging situation (10 seconds by default). This situation can happen for various reasons—for example, an application has an active pending IRP that is never completed by a kernel driver. The WER service opens the hanging process and obtains its token, and some other basic information. It then creates a shared memory section object to store them (similar to user application crashes; in this case, the shared section has a name: Global\<Random GUID>).

A WerFault process is spawned in a suspended state using the faulting process’s token and the **-h** command-line switch (which is used to specify to generate a report for a hanging process). Unlike with user application crashes, a snapshot of the hanging process is taken from the WER service using a full SYSTEM token by invoking the the *PssNtCaptureSnapshot* API exported in Ntdll. The snapshot’s handle is duplicated in the suspended WerFault process, which is resumed after the snapshot has been successfully acquired. When the WerFault starts, it signals an event indicating that the report generation has started. From this stage, the original process can be terminated. Information for the report is grabbed from the cloned process.

The report for a hanging process is similar to the one acquired for a crashing process: The WerFault process starts by querying the value of the *Debugger* registry value located in the global HKLM\Software\Microsoft\Windows\Windows Error Reporting\Hangs root registry key. If there is a valid debugger, it is launched and attached to the original hanging process. In case the *Disable* registry value is set to 1, the procedure is aborted and the WerFault process exits without generating any report. Otherwise, WerFault opens the shared memory section, validates it, and grabs all the information previously saved by the WER service. The report is initialized by using the *WerReportCreate* function exported in WER.dll and used also for crashing processes. The dialog box for a hanging process (shown in Figure 10-44) is always displayed independently on the WER configuration. Finally, the *WerReportSubmit* function (exported in WER.dll) is used to generate all the files for the report (including the minidump file) similarly to user applications crashes (see the “Crash report generation” section earlier in this chapter). The report is finally sent to the Online Crash Analysis server.

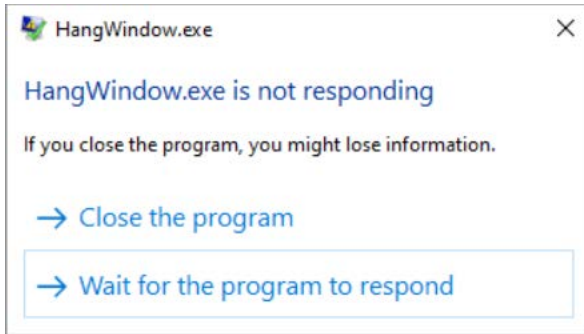

FIGURE 10-44 The Windows Error Reporting dialog box for hanging applications.

After the report generation is started and the `WERSVC_HANG_REPORTING_STARTED` message is returned to DWM, WER kills the hanging process using the `TerminateProcess` API. If the process is not terminated in an expected time frame (generally 10 seconds, but customizable through the `TerminationTimeout` setting as explained earlier), the WER service relaunches another WerFault instance running under a full SYSTEM token and waits another longer timeout (usually 60 seconds but customizable through the `LongTerminationTimeout` setting). If the process is not terminated even by the end of the longer timeout, WER has no other chances than to write an ETW event on the Application event log, reporting the impossibility to terminate the process. The ETW event is shown in Figure 10-45. Note that the event description is misleading because WER hasn't been able to terminate the hanging application.

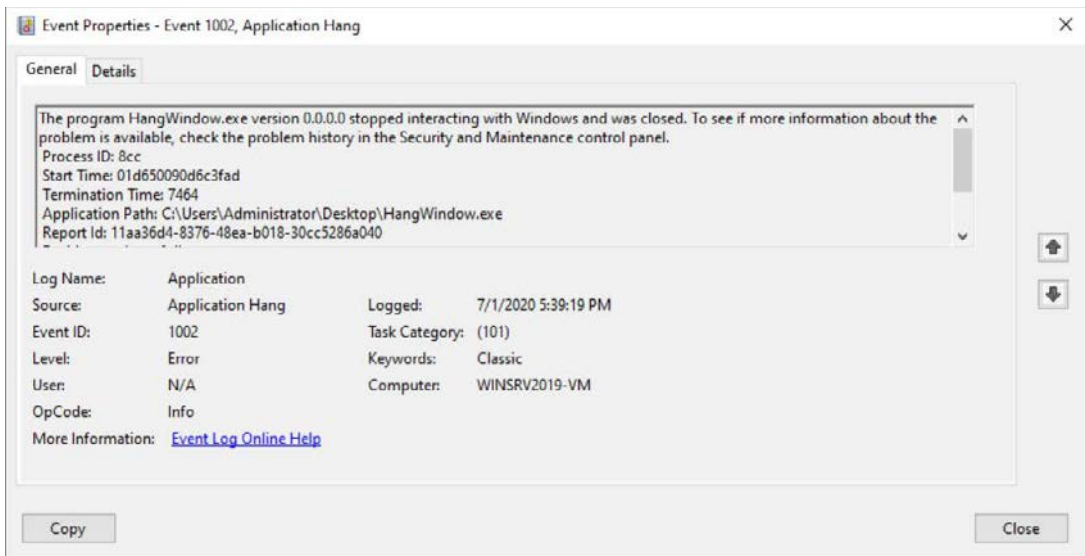

FIGURE 10-45 ETW error event written to the Application log for a nonterminating hanging application.

Global flags

Windows has a set of flags stored in two systemwide global variables named *NtGlobalFlag* and *NtGlobalFlag2* that enable various internal debugging, tracing, and validation support in the operating system. The two system variables are initialized from the registry key HKLM\SYSTEM\CurrentControlSet\Control\Session Manager in the values *GlobalFlag* and *GlobalFlag2* at system boot time (phase 0 of the NT kernel initialization). By default, both registry values are 0, so it's likely that on your systems, you're not using any global flags. In addition, each image has a set of global flags that also turn on internal tracing and validation code (although the bit layout of these flags is slightly different from the systemwide global flags).

Fortunately, the debugging tools contain a utility named *Gflags.exe* that you can use to view and change the system global flags (either in the registry or in the running system) as well as image global flags. *Gflags* has both a command-line and a GUI interface. To see the command-line flags, type **gflags /?**. If you run the utility without any switches, the dialog box shown in Figure 10-46 is displayed.

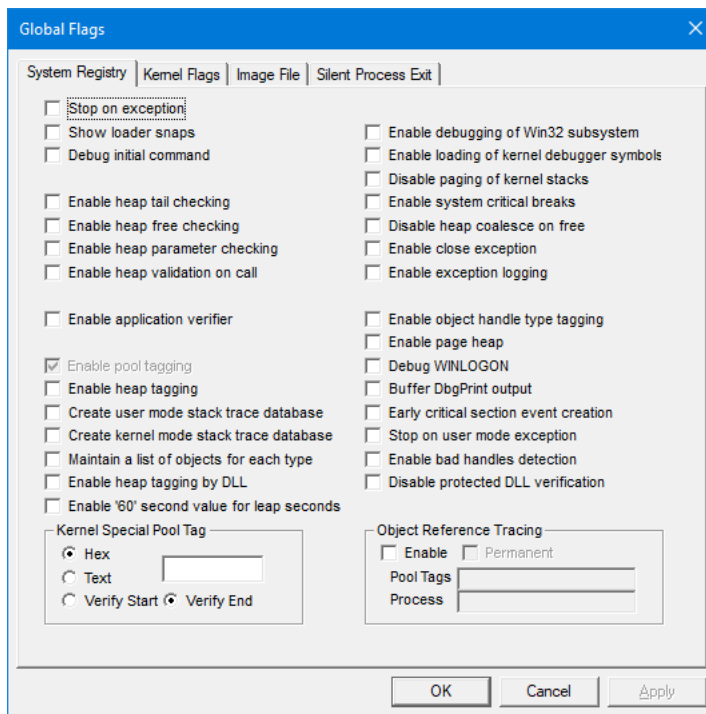

FIGURE 10-46 Setting system debugging options with GFlags.

Flags belonging to the Windows Global flags variables can be split in different categories:

- Kernel flags are processed directly by various components of the NT kernel (the heap manager, exceptions, interrupts handlers, and so on).
- User flags are processed by components running in user-mode applications (usually Ntdll).
- Boot-only flags are processed only when the system is starting.
- Per-image file global flags (which have a slightly different meaning than the others) are processed by the loader, WER, and some other user-mode components, depending on the user-mode process context in which they are running.

The names of the group pages shown by the GFlags tool is a little misleading. Kernel, boot-only, and user flags are mixed together in each page. The main difference is that the System Registry page allows the user to set global flags on the *GlobalFlag* and *GlobalFlag2* registry values, parsed at system boot time. This implies that eventual new flags will be enabled only after the system is rebooted. The Kernel Flags page, despite its name, does not allow kernel flags to be applied on the fly to a live system. Only certain user-mode flags can be set or removed (the enable page heap flag is a good example) without requiring a system reboot: the Gflags tool sets those flags using the *NtSetSystemInformation* native API (with the *SystemFlagsInformation* information class). Only user-mode flags can be set in that way.

EXPERIMENT: Viewing and setting global flags

You can use the `!gflag` kernel debugger command to view and set the state of the *NtGlobalFlag* kernel variable. The `!gflag` command lists all the flags that are enabled. You can use `!gflag -?` to get the entire list of supported global flags. At the time of this writing, the `!gflag` extension has not been updated to display the content of the *NtGlobalFlag2* variable.

The Image File page requires you to fill in the file name of an executable image. Use this option to change a set of global flags that apply to an individual image (rather than to the whole system). The page is shown in Figure 10-47. Notice that the flags are different from the operating system ones shown in Figure 10-46. Most of the flags and the setting available in the Image File and Silent Process Exit pages are applied by storing new values in a subkey with the same name as the image file (that is, `notepad.exe` for the case shown in Figure 10-47) under the `HKLM\SOFTWARE\Microsoft\Windows NT\CurrentVersion\Image File Execution Options` registry key (also known as the IFEO key). In particular, the *GlobalFlag* (and *GlobalFlag2*) value represents a bitmask of all the available per-image global flags.

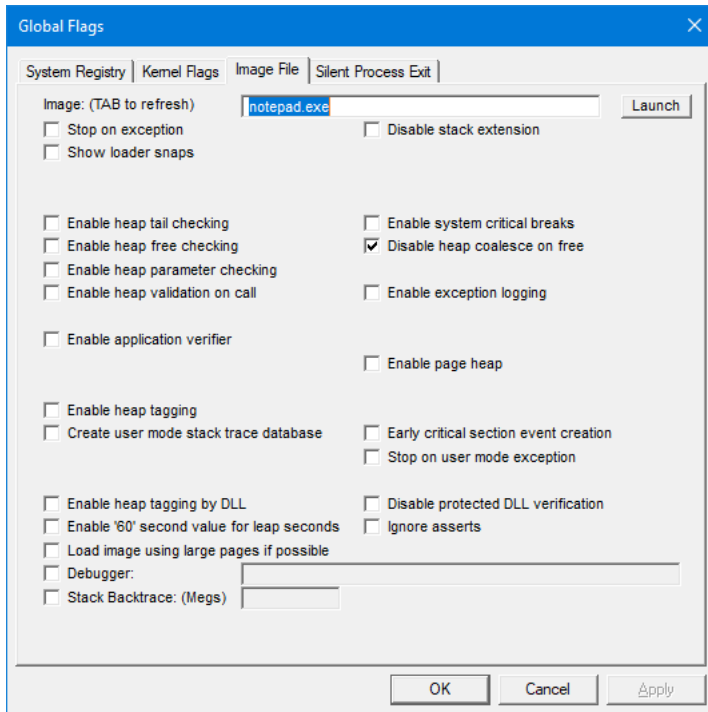

FIGURE 10-47 Setting per-image global flags with GFlags.

When the loader initializes a new process previously created and loads all the dependent libraries of the main base executable (see Chapter 3 of Part 1 for more details about the birth of a process), the system processes the per-image global flags. The *LdrpInitializeExecutionOptions* internal function opens the IFEO key based on the name of the base image and parses all the per-image settings and flags. In particular, after the per-image global flags are retrieved from the registry, they are stored in the *NtGlobalFlag* (and *NtGlobalFlag2*) field of the process PEB. In this way, they can be easily accessed by any image mapped in the process (including Ntdll).

Most of the available global flags are documented at <https://docs.microsoft.com/en-us/windows-hardware/drivers/debugger/gflags-flag-table>.

EXPERIMENT: Troubleshooting Windows loader issues

In the “Watching the image loader” experiment in Chapter 3 of Part 1, you used the GFlags tool to display the Windows loader runtime information. That information can be useful for understanding why an application does not start at all (without returning any useful error information). You can retry the same experiment on *mspaint.exe* by renaming the *Msftedit.dll* file (the Rich Text Edit Control library) located in `%SystemRoot%\system32`. Indeed, Paint depends on that DLL indirectly. The *Msftedit* library is loaded dynamically by *MSCTF.dll*. (It is not statically

linked in the Paint executable.) Open an administrative command prompt window and type the following commands:

```
cd /d c:\windows\system32
takeown /f msftedit.dll
icacls msftedit.dll /grant Administrators:F
ren msftedit.dll msftedit.disabled
```

Then enable the loader snaps using the Gflags tool, as specified in the “Watching the image loader” experiment. If you start mspaint.exe using Windbg, the loader snaps would be able to highlight the problem almost immediately, returning the following text:

```
142c:1e18 @ 00056578 - LdrpInitializeNode - INFO: Calling init routine 00007FFC79258820 for
DLL "C:\Windows\System32\MSCTF.dll"
142c:133c @ 00229625 - LdrpResolveDllName - ENTER: DLL
name: .\MSFTEDIT.DLL
142c:133c @ 00229625 - LdrpResolveDllName - RETURN: Status: 0xc0000135
142c:133c @ 00229625 - LdrpResolveDllName - ENTER: DLL name: C:\Program Files\Debugging Tools
for Windows (x64)\MSFTEDIT.DLL
142c:133c @ 00229625 - LdrpResolveDllName - RETURN: Status: 0xc0000135
142c:133c @ 00229625 - LdrpResolveDllName - ENTER: DLL name: C:\Windows\system32\MSFTEDIT.DLL
142c:133c @ 00229625 - LdrpResolveDllName - RETURN: Status: 0xc0000135
. . .
C:\Users\test\AppData\Local\Microsoft\WindowsApps\MSFTEDIT.DLL
142c:133c @ 00229625 - LdrpResolveDllName - RETURN: Status: 0xc0000135
142c:133c @ 00229625 - LdrpSearchPath - RETURN: Status: 0xc0000135
142c:133c @ 00229625 - LdrpProcessWork - ERROR: Unable to load DLL: "MSFTEDIT.DLL", Parent
Module: "(null)", Status: 0xc0000135
142c:133c @ 00229625 - LdrpLoadDllInternal - RETURN: Status: 0xc0000135
142c:133c @ 00229625 - LdrLoadDll - RETURN: Status: 0xc0000135
```

Kernel shims

New releases of the Windows operating system can sometime bring issues with old drivers, which can have difficulties in operating in the new environment, producing system hangs or blue screens of death. To overcome the problem, Windows 8.1 introduced a Kernel Shim engine that’s able to dynamically modify old drivers, which can continue to run in the new OS release. The Kernel Shim engine is implemented mainly in the NT kernel. Driver’s shims are registered through the Windows Registry and the Shim Database file. Drivers’ shims are provided by shim drivers. A shim driver uses the exported *KseRegisterShimEx* API to register a shim that can be applied to target drivers that need it. The Kernel Shim engine supports mainly two kinds of shims applied to devices or drivers.

Shim engine initialization

In early OS boot stages, the Windows Loader, while loading all the boot-loaded drivers, reads and maps the driver compatibility database file, located in %SystemRoot%\apppatch\Drvmain.sdb (and, if it exists, also in the Drvpatch.sdb file). In phase 1 of the NT kernel initialization, the I/O manager starts the two phases of the Kernel Shim engine initialization. The NT kernel copies the binary content of

the database file(s) in a global buffer allocated from the paged pool (pointed by the internal global *KsepShimDb* variable). It then checks whether Kernel Shims are globally disabled. In case the system has booted in Safe or WinPE mode, or in case Driver verifier is enabled, the shim engine wouldn't be enabled. The Kernel Shim engine is controllable also using system policies or through the HKLM\System\CurrentControlSet\Control\Compatibility\DisableFlags registry value. The NT kernel then gathers low-level system information needed when applying device shims, like the BIOS information and OEM ID, by checking the System *Fixed ACPI Descriptor Table* (FADT). The shim engine registers the first built-in shim provider, named DriverScope, using the *KseRegisterShimEx* API. Built-in shims provided by Windows are listed in Table 10-21. Some of them are indeed implemented in the NT kernel directly and not in any external driver. DriverScope is the only shim registered in phase 0.

TABLE 10-21 Windows built-in kernel shims

Shim Name	GUID	Purpose	Module
<i>DriverScope</i>	{BC04AB45-EA7E-4A11-A7BB-977615F4CAAE}	The driver scope shim is used to collect health ETW events for a target driver. Its hooks do nothing other than writing an ETW event before or after calling the original nonshimmed callbacks.	NT kernel
<i>Version Lie</i>	{3E28B2D1-E633-408C-8E9B-2AFA6F47FCC3} (7.1) {47712F55-BD93-43FC-9248-B9A83710066E} (8) {21C4FB58-D477-4839-A7EA-AD6918FBC518} (8.1)	The version lie shim is available for Windows 7, 8, and 8.1. The shim communicates a previous version of the OS when required by a driver in which it is applied.	NT kernel
<i>SkipDriverUnload</i>	{3E8C2CA6-34E2-4DE6-8A1E-9692DD3E316B}	The shim replaces the driver's unload routine with one that doesn't do anything except logging an ETW event.	NT kernel
<i>ZeroPool</i>	{6B847429-C430-4682-B55F-FD11A7B55465}	Replace the <i>ExAllocatePool</i> API with a function that allocates the pool memory and zeroes it out.	NT kernel
<i>ClearPCIDBits</i>	{B4678DFF-BD3E-46C9-923B-B5733483B0B3}	Clear the PCID bits when some antivirus drivers are mapping physical memory referred by CR3.	NT kernel
<i>Kaspersky</i>	{B4678DFF-CC3E-46C9-923B-B5733483B0B3}	Shim created for specific Kaspersky filter drivers for masking the real value of the <i>UseVtHardware</i> registry value, which could have caused bug checks on old versions of the antivirus.	NT kernel
<i>Memcpy</i>	{8A2517C1-35D6-4CA8-9EC8-98A12762891B}	Provides a safer (but slower) memory copy implementation that always zeroes out the destination buffer and can be used with device memory.	NT kernel
<i>KernelPadSectionsOverride</i>	{4F55C0DB-73D3-43F2-9723-8A9C7F79D39D}	Prevents discardable sections of any kernel module to be freed by the memory manager and blocks the loading of the target driver (where the shim is applied).	NT kernel
<i>NDIS Shim</i>	{49691313-1362-4e75-8c2a-2dd72928eba5}	NDIS version compatibility shim (returns 6.40 where applied to a driver).	Ndis.sys
<i>SrbShim</i>	{434ABAFD-08FA-4c3d-A88D-D09A88E2AB17}	SCSI Request Block compatibility shim that intercepts the <i>IOCTL_STORAGE_QUERY_PROPERTY</i> .	Storport.sys

Shim Name	GUID	Purpose	Module
<i>DeviceldShim</i>	{0332ec62-865a-4a39-b48f-cda6e855f423}	Compatibility shim for RAID devices.	Storport.sys
<i>ATADeviceldShim</i>	{26665d57-2158-4e4b-a959-c917d03a0d7e}	Compatibility shim for serial ATA devices.	Storport.sys
<i>Bluetooth Filter Power shim</i>	{6AD90DAD-C144-4E9D-A0CF-AE9FCB901EBD}	Compatibility shim for Bluetooth filter drivers.	Bthport.sys
<i>UsbShim</i>	{fd8fd62e-4d94-4fc7-8a68-bff7865a706b}	Compatibility shim for old Conexant USB modem.	Usbd.sys
<i>Nokia Usbser Filter Shim</i>	{7DD60997-651F-4ECB-B893-BEC8050F3BD7}	Compatibility shim for Nokia Usbser filter drivers (used by Nokia PC Suite).	Usbd.sys

A shim is internally represented through the *KSE_SHIM* data structure (where KSE stands for Kernel Shim Engine). The data structure includes the GUID, the human-readable name of the shim, and an array of hook collection (*KSE_HOOK_COLLECTION* data structures). Driver shims support different kinds of hooks: hooks on functions exported by the NT kernel, HAL, and by driver libraries, and on driver's object callback functions. In phase 1 of its initialization, the Shim Engine registers the Microsoft-Windows-Kernel-ShimEngine ETW provider (which has the {0bf2fb94-7b60-4b4d-9766-e82f658df540} GUID), opens the driver shim database, and initializes the remaining built-in shims implemented in the NT kernel (refer to Table 10-21).

To register a shim (through *KseRegisterShimEx*), the NT kernel performs some initial integrity checks on both the *KSE_SHIM* data structure, and each hook in the collection (all the hooks must reside in the address space of the calling driver). It then allocates and fills a *KSE_REGISTERED_SHIM_ENTRY* data structure which, as the name implies, represents the registered shim. It contains a reference counter and a pointer back to the driver object (used only in case the shim is not implemented in the NT kernel). The allocated data structure is linked in a global linked list, which keeps track of all the registered shims in the system.

The shim database

The shim database (SDB) file format was first introduced in the old Windows XP for Application Compatibility. The initial goal of the file format was to store a binary XML-style database of programs and drivers that needed some sort of help from the operating system to work correctly. The SDB file has been adapted to include kernel-mode shims. The file format describes an XML database using tags. A tag is a 2-byte basic data structure used as unique identifier for entries and attributes in the database. It is made of a 4-bit type, which identifies the format of the data associated with the tag, and a 12-bit index. Each tag indicates the data type, size, and interpretation that follows the tag itself. An SDB file has a 12-byte header and a set of tags. The set of tags usually defines three main blocks in the shim database file:

- The INDEX block contains index tags that serve to fast-index elements in the database. Indexes in the INDEX block are stored in increasing order. Therefore, searching an element in the indexes is a fast operation (using a binary search algorithm). For the Kernel Shim engine, the elements are stored in the INDEXES block using an 8-byte key derived from the shim name.

- The DATABASE block contains top-level tags describing shims, drivers, devices, and executables. Each top-level tag contains children tags describing properties or inner blocks belonging to the root entity.
- The STRING TABLE block contains strings that are referenced by lower-level tags in the DATABASE block. Tags in the DATABASE block usually do not directly describe a string but instead contain a reference to a tag (called STRINGREF) describing a string located in the string table. This allows databases that contain a lot of common strings to be small in size.

Microsoft has partially documented the SDB file format and the APIs used to read and write it at <https://docs.microsoft.com/en-us/windows/win32/devnotes/application-compatibility-database>. All the SDB APIs are implemented in the Application Compatibility Client Library (apphelp.dll).

Driver shims

The NT memory manager decides whether to apply a shim to a kernel driver at its loading time, using the *KseDriverLoadImage* function (boot-loaded drivers are processed by the I/O manager, as discussed in Chapter 12). The routine is called at the correct time of a kernel-module life cycle, before either Driver Verifier, Import Optimization, or Kernel Patch protection are applied to it. (This is important; otherwise, the system would bugcheck.) A list of the current shimmed kernel modules is stored in a global variable. The *KsepGetShimsForDriver* routine checks whether a module in the list with the same base address as the one being loaded is currently present. If so, it means that the target module has already been shimmed, so the procedure is aborted. Otherwise, to determine whether the new module should be shimmed, the routine checks two different sources:

- Queries the “Shims” multistring value from a registry key named as the module being loaded and located in the HKLM\System\CurrentControlSet\Control\Compatibility\Driver root key. The registry value contains an array of shims’ names that would be applied to the target module.
- In case the registry value for a target module does not exist, parses the driver compatibility database file, looking for a KDRIVER tag (indexed by the INDEX block), which has the same name as the module being loaded. If a driver is found in the SDB file, the NT kernel performs a comparison of the driver version (TAG_SOURCE_OS stored in the KDRIVER root tag), file name, and path (if the relative tags exist in the SDB), and of the low-level system information gathered at engine initialization time (to determine if the driver is compatible with the system). In case any of the information does not match, the driver is skipped, and no shims are applied. Otherwise, the shim names list is grabbed from the KSHIM_REF lower-level tags (which is part of the root KDRIVER). The tags are reference to the KSHIMs located in the SDB database block.

If one of the two sources yields one or more shims names to be applied to the target driver, the SDB file is parsed again with the goal to validate that a valid KSHIM descriptor exists. If there are no tags related to the specified shim name (which means that no shim descriptor exists in the database), the procedure is interrupted (this prevents an administrator from applying random non-Microsoft shims to a driver). Otherwise, an array of *KSE_SHIM_INFO* data structure is returned to *KsepGetShimsForDriver*.

The next step is to determine if the shims described by their descriptors have been registered in the system. To do this, the Shim engine searches into the global linked list of registered shims (filled every time a new shim is registered, as explained previously in the “Shim Engine initialization” section). If a shim is not registered, the shim engine tries to load the driver that provides it (its name is stored in the `MODULE` child tag of the root `KSHIM` entry) and tries again. When a shim is applied for the first time, the Shim engine resolves the pointers of all the hooks described by the `KSE_HOOK_COLLECTION` data structures’ array belonging to the registered shim (`KSE_SHIM` data structure). The shim engine allocates and fills a `KSE_SHIMMED_MODULE` data structure representing the target module to be shimmed (which includes the base address) and adds it to the global list checked in the beginning.

At this stage, the shim engine applies the shim to the target module using the internal `KsepApplyShimsToDriver` routine. The latter cycles between each hook described by the `KSE_HOOK_COLLECTION` array and patches the import address table (IAT) of the target module, replacing the original address of the hooked functions with the new ones (described by the hook collection). Note that the driver’s object callback functions (IRP handlers) are not processed at this stage. They are modified later by the I/O manager before the `DriverInit` routine of the target driver is called. The original driver’s IRP callback routines are saved in the Driver Extension of the target driver. In that way, the hooked functions have a simple way to call back into the original ones when needed.

EXPERIMENT: Witnessing kernel shims

While the official Microsoft Application Compatibility Toolkit distributed with the Windows Assessment and Deployment Kit allows you to open, modify, and create shim database files, it does not work with system database files (identified through to their internal GUIDs), so it won’t be able to parse all the kernel shims that are described by the `drvmain.sdb` database. Multiple third-party SDB parsers exist. One in particular, called SDB explorer, is freely downloadable from <https://ericzimmerman.github.io/>.

In this experiment, you get a peek at the `drvmain` system database file and apply a kernel shim to a test driver, `ShimDriver`, which is available in this book’s downloadable resources. For this experiment, you need to enable test signing (the `ShimDriver` is signed with a test self-signed certificate):

1. Open an administrative command prompt and type the following command:

```
bcdedit /set testsigning on
```
2. Restart your computer, download SDB Explorer from its website, run it, and open the `drvmain.sdb` database located in `%SystemRoot%\apppatch`.
3. From the SDB Explorer main window, you can explore the entire database file, organized in three main blocks: Indexes, Databases, and String table. Expand the `DATABASES` root block and scroll down until you can see the list of `KSHIMs` (they should be located after the `KDEVICES`). You should see a window similar to the following:

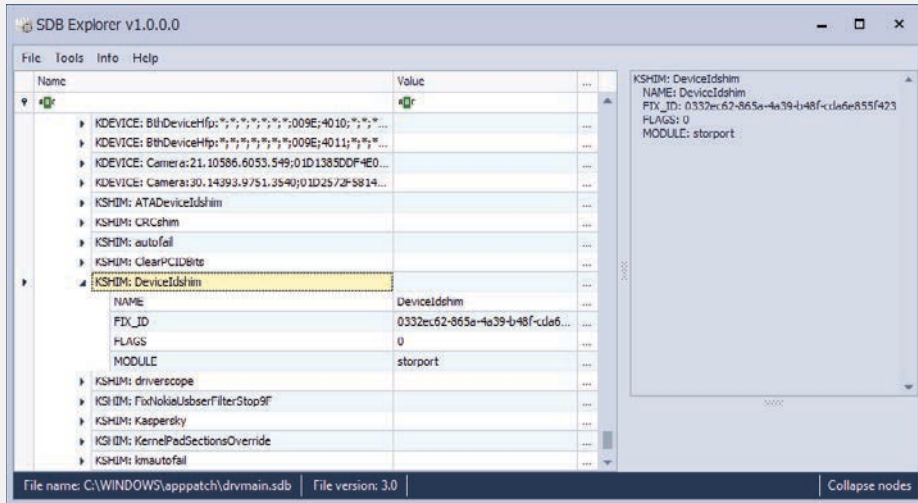

4. You will apply one of the Version lie shims to our test driver. First, you should copy the ShimDriver to the %SystemRoot%\System32\Drivers. Then you should install it by typing the following command in the administrative command prompt (it is assumed that your system is 64-bit):

```
sc create ShimDriver type= kernel start= demand error= normal binPath= c:\Windows\System32\ShimDriver64.sys
```

5. Before starting the test driver, you should download and run the DebugView tool, available in the Sysinternals website (<https://docs.microsoft.com/en-us/sysinternals/downloads/debugview>). This is necessary because ShimDriver prints some debug messages.
6. Start the ShimDriver with the following command:

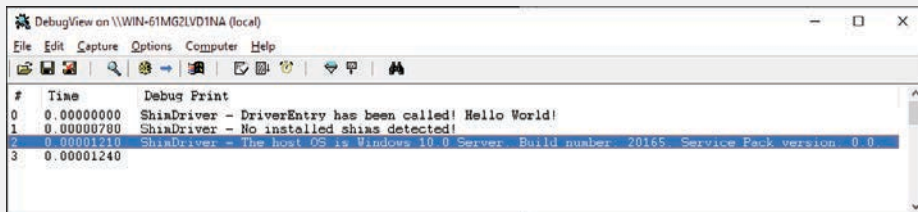

```
sc start shimdriver
```
7. Check the output of the DebugView tool. You should see messages like the one shown in the following figure. What you see depends on the Windows version in which you run the driver. In the example, we run the driver on an insider release version of Windows Server 2022:



- Now you should stop the driver and enable one of the shims present in the SDB database. In this example, you will start with one of the version lie shims. Stop the target driver and install the shim using the following commands (where ShimDriver64.sys is the driver's file name installed with the previous step):

```
sc stop shimdriver
reg add "HKLM\System\CurrentControlSet\Control\Compatibility\Driver\
    ShimDriver64.sys" /v Shims /t REG_MULTI_SZ /d
KmWin81VersionLie /f /reg:64
```

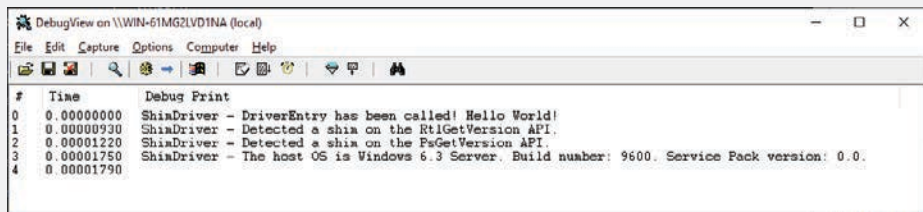
- The last command adds the Windows 8.1 version lie shim, but you can freely choose other versions.
- Now, if you restart the driver, you will see different messages printed by the DebugView tool, as shown in the following figure:



- This is because the shim engine has correctly applied the hooks on the NT APIs used for retrieving OS version information (the driver is able to detect the shim, too). You should be able to repeat the experiment using other shims, like the SkipDriverUnload or the KernelPadSectionsOverride, which will zero out the driver unload routine or prevent the target driver from loading, as shown in the following figure:

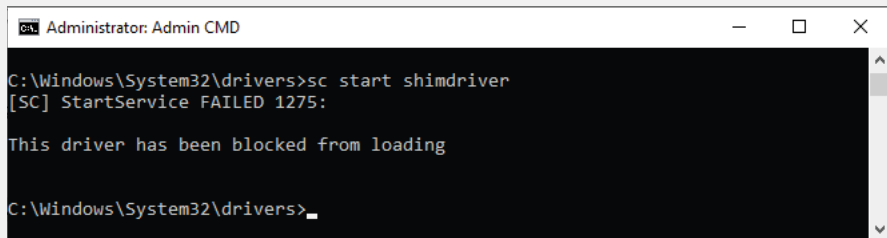

Device shims

Unlike Driver shims, shims applied to Device objects are loaded and applied on demand. The NT kernel exports the *KseQueryDeviceData* function, which allows drivers to check whether a shim needs to be applied to a device object. (Note also that the *KseQueryDeviceFlags* function is exported. The API is just a subset of the first one, though.) Querying for device shims is also possible for user-mode applications through the *NtQuerySystemInformation* API used with the *SystemDeviceDataInformation* information class. Device shims are always stored in three different locations, consulted in the following order:

1. In the HKLM\System\CurrentControlSet\Control\Compatibility\Device root registry key, using a key named as the PNP hardware ID of the device, replacing the \ character with a ! (with the goal to not confuse the registry). Values in the device key specify the device's shimmed data being queried (usually flags for a certain device class).
2. In the kernel shim cache. The Kernel Shim engine implements a shim cache (exposed through the *KSE_CACHE* data structure) with the goal of speeding up searches for device flags and data.
3. In the Shim database file, using the KDEVICE root tag. The root tag, among many others (like device description, manufacturer name, GUID and so on), includes the child NAME tag containing a string composed as follows: <DataName:HardwareID>. The KFLAG or KDATA children tags include the value for the device's shimmed data.

If the device shim is not present in the cache but just in the SDB file, it is always added. In that way, future interrogation would be faster and will not require any access to the Shim database file.

Conclusion

In this chapter, we have described the most important features of the Windows operating system that provide management facilities, like the Windows Registry, user-mode services, task scheduling, UBPM, and Windows Management Instrumentation (WMI). Furthermore, we have discussed how Event Tracing for Windows (ETW), DTrace, Windows Error Reporting (WER), and Global Flags (GFlags) provide the services that allow users to better trace and diagnose issues arising from any component of the OS or user-mode applications. The chapter concluded with a peek at the Kernel Shim engine, which helps the system apply compatibility strategies and correctly execute old components that have been designed for older versions of the operating system.

The next chapter delves into the different file systems available in Windows and with the global caching available for speeding up file and data access.

Caching and file systems

The cache manager is a set of kernel-mode functions and system threads that cooperate with the memory manager to provide data caching for all Windows file system drivers (both local and network). In this chapter, we explain how the cache manager, including its key internal data structures and functions, works; how it is sized at system initialization time; how it interacts with other elements of the operating system; and how you can observe its activity through performance counters. We also describe the five flags on the Windows CreateFile function that affect file caching and DAX volumes, which are memory-mapped disks that bypass the cache manager for certain types of I/O.

The services exposed by the cache manager are used by all the Windows File System drivers, which cooperate strictly with the former to be able to manage disk I/O as fast as possible. We describe the different file systems supported by Windows, in particular with a deep analysis of NTFS and ReFS (the two most used file systems). We present their internal architecture and basic operations, including how they interact with other system components, such as the memory manager and the cache manager.

The chapter concludes with an overview of Storage Spaces, the new storage solution designed to replace dynamic disks. Spaces can create tiered and thinly provisioned virtual disks, providing features that can be leveraged by the file system that resides at the top.

Terminology

To fully understand this chapter, you need to be familiar with some basic terminology:

- *Disks* are physical storage devices such as a hard disk, CD-ROM, DVD, Blu-ray, solid-state disk (SSD), Non-volatile Memory disk (NVMe), or flash drive.
- *Sectors* are hardware-addressable blocks on a storage medium. Sector sizes are determined by hardware. Most hard disk sectors are 4,096 or 512 bytes, DVD-ROM and Blu-ray sectors are typically 2,048 bytes. Thus, if the sector size is 4,096 bytes and the operating system wants to modify the 5120th byte on a disk, it must write a 4,096-byte block of data to the second sector on the disk.
- *Partitions* are collections of contiguous sectors on a disk. A partition table or other disk-management database stores a partition's starting sector, size, and other characteristics and is located on the same disk as the partition.
- *Volumes* are objects that represent sectors that file system drivers always manage as a single unit. Simple volumes represent sectors from a single partition, whereas multipartition volumes

represent sectors from multiple partitions. Multipartition volumes offer performance, reliability, and sizing features that simple volumes do not.

- *File system formats* define the way that file data is stored on storage media, and they affect a file system's features. For example, a format that doesn't allow user permissions to be associated with files and directories can't support security. A file system format also can impose limits on the sizes of files and storage devices that the file system supports. Finally, some file system formats efficiently implement support for either large or small files or for large or small disks. NTFS, exFAT, and ReFS are examples of file system formats that offer different sets of features and usage scenarios.
- *Clusters* are the addressable blocks that many file system formats use. Cluster size is always a multiple of the sector size, as shown in Figure 11-1, in which eight sectors make up each cluster, which are represented by a yellow band. File system formats use clusters to manage disk space more efficiently; a cluster size that is larger than the sector size divides a disk into more manageable blocks. The potential trade-off of a larger cluster size is wasted disk space, or internal fragmentation, that results when file sizes aren't exact multiples of the cluster size.

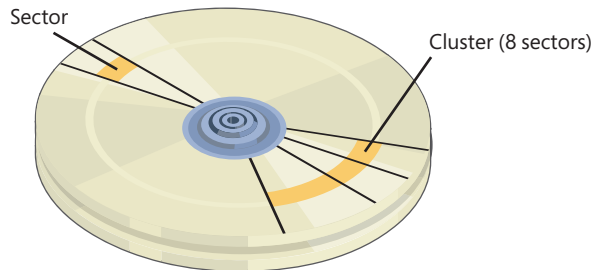

FIGURE 11-1 Sectors and clusters on a classical spinning disk.

- *Metadata* is data stored on a volume in support of file system format management. It isn't typically made accessible to applications. Metadata includes the data that defines the placement of files and directories on a volume, for example.

Key features of the cache manager

The cache manager has several key features:

- Supports all file system types (both local and network), thus removing the need for each file system to implement its own cache management code.
- Uses the memory manager to control which parts of which files are in physical memory (trading off demands for physical memory between user processes and the operating system).
- Caches data on a virtual block basis (offsets within a file)—in contrast to many caching systems, which cache on a logical block basis (offsets within a disk volume)—allowing for intelligent

read-ahead and high-speed access to the cache without involving file system drivers. (This method of caching, called *fast I/O*, is described later in this chapter.)

- Supports “hints” passed by applications at file open time (such as random versus sequential access, temporary file creation, and so on).
- Supports recoverable file systems (for example, those that use transaction logging) to recover data after a system failure.
- Supports solid state, NVMe, and direct access (DAX) disks.

Although we talk more throughout this chapter about how these features are used in the cache manager, in this section we introduce you to the concepts behind these features.

Single, centralized system cache

Some operating systems rely on each individual file system to cache data, a practice that results either in duplicated caching and memory management code in the operating system or in limitations on the kinds of data that can be cached. In contrast, Windows offers a centralized caching facility that caches all externally stored data, whether on local hard disks, USB removable drives, network file servers, or DVD-ROMs. Any data can be cached, whether it’s user data streams (the contents of a file and the ongoing read and write activity to that file) or file *system metadata* (such as directory and file headers). As we discuss in this chapter, the method Windows uses to access the cache depends on the type of data being cached.

The memory manager

One unusual aspect of the cache manager is that it never knows how much cached data is actually in physical memory. This statement might sound strange because the purpose of a cache is to keep a subset of frequently accessed data in physical memory as a way to improve I/O performance. The reason the cache manager doesn’t know how much data is in physical memory is that it accesses data by mapping views of files into system virtual address spaces, using standard *section objects* (or *file mapping objects* in Windows API terminology). (Section objects are a basic primitive of the memory manager and are explained in detail in Chapter 5, “Memory Management” of Part 1). As addresses in these mapped views are accessed, the memory manager pages-in blocks that aren’t in physical memory. And when memory demands dictate, the memory manager unmaps these pages out of the cache and, if the data has changed, pages the data back to the files.

By caching on the basis of a virtual address space using mapped files, the cache manager avoids generating read or write I/O request packets (IRPs) to access the data for files it’s caching. Instead, it simply copies data to or from the virtual addresses where the portion of the cached file is mapped and relies on the memory manager to fault in (or out) the data in to (or out of) memory as needed. This process allows the memory manager to make global trade-offs on how much RAM to give to the system cache versus how much to give to user processes. (The cache manager also initiates I/O, such as lazy writing, which we describe later in this chapter; however, it calls the memory manager to write the pages.) Also, as we discuss in the next section, this design makes it possible for processes that open cached files to see the same data as do other processes that are mapping the same files into their user address spaces.

Cache coherency

One important function of a cache manager is to ensure that any process that accesses cached data will get the most recent version of that data. A problem can arise when one process opens a file (and hence the file is cached) while another process maps the file into its address space directly (using the Windows *MapViewOfFile* function). This potential problem doesn't occur under Windows because both the cache manager and the user applications that map files into their address spaces use the same memory management file mapping services. Because the memory manager guarantees that it has only one representation of each unique mapped file (regardless of the number of section objects or mapped views), it maps all views of a file (even if they overlap) to a single set of pages in physical memory, as shown in Figure 11-2. (For more information on how the memory manager works with mapped files, see Chapter 5 of Part 1.)

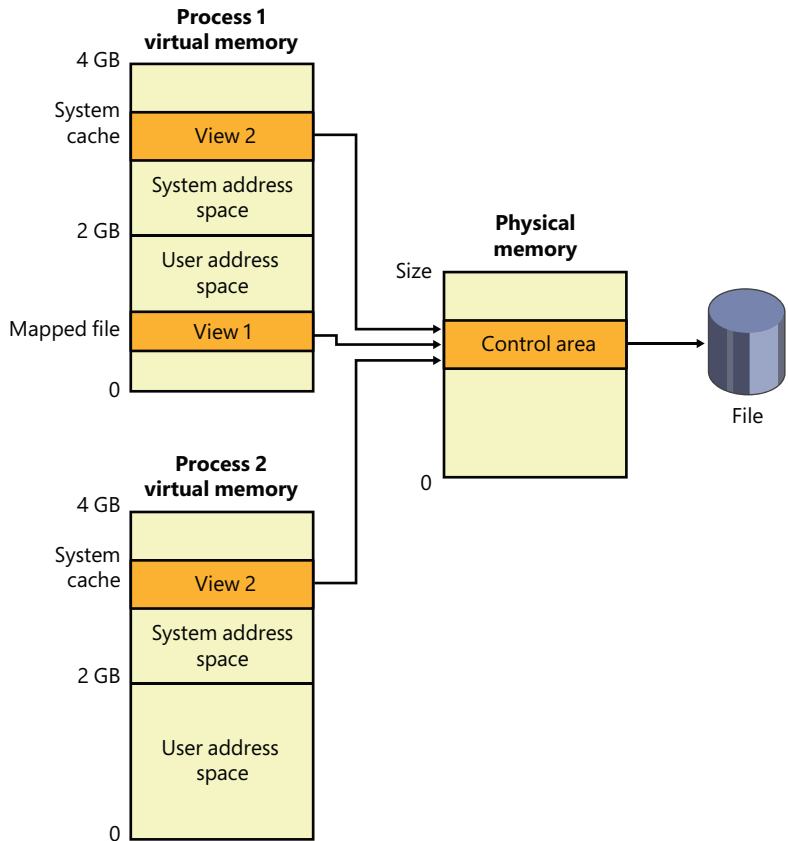

FIGURE 11-2 Coherent caching scheme.

So, for example, if Process 1 has a view (View 1) of the file mapped into its user address space, and Process 2 is accessing the same view via the system cache, Process 2 sees any changes that Process 1 makes as they're made, not as they're flushed. The memory manager won't flush *all* user-mapped

pages—only those that it knows have been written to (because they have the modified bit set). Therefore, any process accessing a file under Windows always sees the most up-to-date version of that file, even if some processes have the file open through the I/O system and others have the file mapped into their address space using the Windows file mapping functions.



Note Cache coherency in this case refers to coherency between user-mapped data and cached I/O and not between noncached and cached hardware access and I/Os, which are almost guaranteed to be incoherent. Also, cache coherency is somewhat more difficult for network redirectors than for local file systems because network redirectors must implement additional flushing and purge operations to ensure cache coherency when accessing network data.

Virtual block caching

The Windows cache manager uses a method known as *virtual block caching*, in which the cache manager keeps track of which parts of which *files* are in the cache. The cache manager is able to monitor these file portions by mapping 256 KB views of files into system virtual address spaces, using special system cache routines located in the memory manager. This approach has the following key benefits:

- It opens up the possibility of doing intelligent read-ahead; because the cache tracks which parts of which files are in the cache, it can predict where the caller might be going next.
- It allows the I/O system to bypass going to the file system for requests for data that is already in the cache (fast I/O). Because the cache manager knows which parts of which files are in the cache, it can return the address of cached data to satisfy an I/O request without having to call the file system.

Details of how intelligent read-ahead and fast I/O work are provided later in this chapter in the “Fast I/O” and “Read-ahead and write-behind” sections.

Stream-based caching

The cache manager is also designed to do *stream caching* rather than file caching. A *stream* is a sequence of bytes within a file. Some file systems, such as NTFS, allow a file to contain more than one stream; the cache manager accommodates such file systems by caching each stream independently. NTFS can exploit this feature by organizing its master file table (described later in this chapter in the “Master file table” section) into streams and by caching these streams as well. In fact, although the cache manager might be said to cache files, it actually caches streams (all files have at least one stream of data) identified by both a file name and, if more than one stream exists in the file, a stream name.



Note Internally, the cache manager is not aware of file or stream names but uses pointers to these structures.

Recoverable file system support

Recoverable file systems such as NTFS are designed to reconstruct the disk volume structure after a system failure. This capability means that I/O operations in progress at the time of a system failure must be either entirely completed or entirely backed out from the disk when the system is restarted. Half-completed I/O operations can corrupt a disk volume and even render an entire volume inaccessible. To avoid this problem, a recoverable file system maintains a log file in which it records every update it intends to make to the file system structure (the file system's metadata) before it writes the change to the volume. If the system fails, interrupting volume modifications in progress, the recoverable file system uses information stored in the log to reissue the volume updates.

To guarantee a successful volume recovery, every log file record documenting a volume update must be completely written to disk before the update itself is applied to the volume. Because disk writes are cached, the cache manager and the file system must coordinate metadata updates by ensuring that the log file is flushed ahead of metadata updates. Overall, the following actions occur in sequence:

1. The file system writes a log file record documenting the metadata update it intends to make.
2. The file system calls the cache manager to flush the log file record to disk.
3. The file system writes the volume update to the cache—that is, it modifies its cached metadata.
4. The cache manager flushes the altered metadata to disk, updating the volume structure. (Actually, log file records are batched before being flushed to disk, as are volume modifications.)



Note The term *metadata* applies only to changes in the file system structure: file and directory creation, renaming, and deletion.

When a file system writes data to the cache, it can supply a *logical sequence number* (LSN) that identifies the record in its log file, which corresponds to the cache update. The cache manager keeps track of these numbers, recording the lowest and highest LSNs (representing the oldest and newest log file records) associated with each page in the cache. In addition, data streams that are protected by transaction log records are marked as “no write” by NTFS so that the mapped page writer won't inadvertently write out these pages before the corresponding log records are written. (When the mapped page writer sees a page marked this way, it moves the page to a special list that the cache manager then flushes at the appropriate time, such as when lazy writer activity takes place.)

When it prepares to flush a group of dirty pages to disk, the cache manager determines the highest LSN associated with the pages to be flushed and reports that number to the file system. The file system can then call the cache manager back, directing it to flush log file data up to the point represented by the reported LSN. *After* the cache manager flushes the log file up to that LSN, it flushes the corresponding volume structure updates to disk, thus ensuring that it records what it's going to do before actually doing it. These interactions between the file system and the cache manager guarantee the recoverability of the disk volume after a system failure.

NTFS MFT working set enhancements

As we have described in the previous paragraphs, the mechanism that the cache manager uses to cache files is the same as general memory mapped I/O interfaces provided by the memory manager to the operating system. For accessing or caching a file, the cache manager maps a view of the file in the system virtual address space. The contents are then accessed simply by reading off the mapped virtual address range. When the cached content of a file is no longer needed (for various reasons—see the next paragraphs for details), the cache manager unmaps the view of the file. This strategy works well for any kind of data files but has some problems with the metadata that the file system maintains for correctly storing the files in the volume.

When a file handle is closed (or the owning process dies), the cache manager ensures that the cached data is no longer in the working set. The NTFS file system accesses the Master File Table (MFT) as a big file, which is cached like any other user files by the cache manager. The problem with the MFT is that, since it is a system file, which is mapped and processed in the System process context, nobody will ever close its handle (unless the volume is unmounted), so the system never unmaps any cached view of the MFT. The process that initially caused a particular view of MFT to be mapped might have closed the handle or exited, leaving potentially unwanted views of MFT still mapped into memory consuming valuable system cache (these views will be unmapped only if the system runs into memory pressure).

Windows 8.1 resolved this problem by storing a reference counter to every MFT record in a dynamically allocated multilevel array, which is stored in the NTFS file system Volume Control Block (VCB) structure. Every time a File Control Block (FCB) data structure is created (further details on the FCB and VCB are available later in this chapter), the file system increases the counter of the relative MFT index record. In the same way, when the FCB is destroyed (meaning that all the handles to the file or directory that the MFT entry refers to are closed), NTFS dereferences the relative counter and calls the *CcUnmapFileOffsetFromSystemCache* cache manager routine, which will unmap the part of the MFT that is no longer needed.

Memory partitions support

Windows 10, with the goal to provide support for Hyper-V containers and game mode, introduced the concept of partitions. Memory partitions have already been described in Chapter 5 of Part 1. As seen in that chapter, memory partitions are represented by a large data structure (MI_PARTITION), which maintains memory-related management structures related to the partition, such as page lists (standby, modified, zero, free, and so on), commit charge, working set, page trimmer, modified page writer, and zero-page thread. The cache manager needs to cooperate with the memory manager in order to support partitions. During phase 1 of NT kernel initialization, the system creates and initializes the cache manager partition (for further details about Windows kernel initialization, see Chapter 12, “Startup and shutdown”), which will be part of the System Executive partition (*MemoryPartition0*). The cache manager’s code has gone through a big refactoring to support partitions; all the global cache manager data structures and variables have been moved in the cache manager partition data structure (*CC_PARTITION*).

The cache manager's partition contains cache-related data, like the global shared cache maps list, the worker threads list (read-ahead, write-behind, and extra write-behind; lazy writer and lazy writer scan; async reads), lazy writer scan events, an array that holds the history of write-behind throughout, the upper and lower limit for the dirty pages threshold, the number of dirty pages, and so on. When the cache manager system partition is initialized, all the needed system threads are started in the context of a System process which belongs to the partition. Each partition always has an associated minimal System process, which is created at partition-creation time (by the *NtCreatePartition* API).

When the system creates a new partition through the *NtCreatePartition* API, it always creates and initializes an empty *ML_PARTITION* object (the memory is moved from a parent partition to the child, or hot-added later by using the *NtManagePartition* function). A cache manager partition object is created only on-demand. If no files are created in the context of the new partition, there is no need to create the cache manager partition object. When the file system creates or opens a file for caching access, the *CcInitializeCacheMap(Ex)* function checks which partition the file belongs to and whether the partition has a valid link to a cache manager partition. In case there is no cache manager partition, the system creates and initializes a new one through the *CcCreatePartition* routine. The new partition starts separate cache manager-related threads (read-ahead, lazy writers, and so on) and calculates the new values of the dirty page threshold based on the number of pages that belong to the specific partition.

The file object contains a link to the partition it belongs to through its control area, which is initially allocated by the file system driver when creating and mapping the Stream Control Block (SCB). The partition of the target file is stored into a file object extension (of type *MemoryPartitionInformation*) and is checked by the memory manager when creating the section object for the SCB. In general, files are shared entities, so there is no way for File System drivers to automatically associate a file to a different partition than the System Partition. An application can set a different partition for a file using the *NtSetInformationFileKernel* API, through the new *FileMemoryPartitionInformation* class.

Cache virtual memory management

Because the Windows system cache manager caches data on a virtual basis, it uses up regions of system virtual address space (instead of physical memory) and manages them in structures called *virtual address control blocks*, or VACBs. VACBs define these regions of address space into 256 KB slots called *views*. When the cache manager initializes during the bootup process, it allocates an initial array of VACBs to describe cached memory. As caching requirements grow and more memory is required, the cache manager allocates more VACB arrays, as needed. It can also shrink virtual address space as other demands put pressure on the system.

At a file's first I/O (read or write) operation, the cache manager maps a 256 KB view of the 256 KB-aligned region of the file that contains the requested data into a free slot in the system cache address space. For example, if 10 bytes starting at an offset of 300,000 bytes were read into a file, the view that would be mapped would begin at offset 262144 (the second 256 KB-aligned region of the file) and extend for 256 KB.

The cache manager maps views of files into slots in the cache's address space on a round-robin basis, mapping the first requested view into the first 256 KB slot, the second view into the second 256 KB slot, and so forth, as shown in Figure 11-3. In this example, File B was mapped first, File A second, and File C third, so File B's mapped chunk occupies the first slot in the cache. Notice that only the first 256 KB portion of File B has been mapped, which is due to the fact that only part of the file has been accessed. Because File C is only 100 KB (and thus smaller than one of the views in the system cache), it requires its own 256 KB slot in the cache.

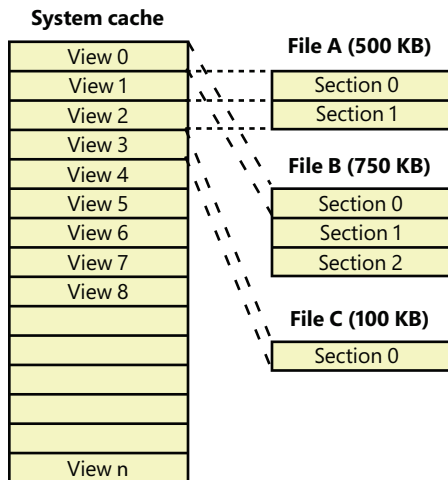

FIGURE 11-3 Files of varying sizes mapped into the system cache.

The cache manager guarantees that a view is mapped as long as it's active (although views can remain mapped after they become inactive). A view is marked active, however, only during a read or write operation to or from the file. Unless a process opens a file by specifying the `FILE_FLAG_RANDOM_ACCESS` flag in the call to `CreateFile`, the cache manager unmaps inactive views of a file as it maps new views for the file if it detects that the file is being accessed sequentially. Pages for unmapped views are sent to the standby or modified lists (depending on whether they have been changed), and because the memory manager exports a special interface for the cache manager, the cache manager can direct the pages to be placed at the end or front of these lists. Pages that correspond to views of files opened with the `FILE_FLAG_SEQUENTIAL_SCAN` flag are moved to the front of the lists, whereas all others are moved to the end. This scheme encourages the reuse of pages belonging to sequentially read files and specifically prevents a large file copy operation from affecting more than a small part of physical memory. The flag also affects unmapping. The cache manager will aggressively unmap views when this flag is supplied.

If the cache manager needs to map a view of a file, and there are no more free slots in the cache, it will unmap the least recently mapped inactive view and use that slot. If no views are available, an I/O error is returned, indicating that insufficient system resources are available to perform the operation. Given that views are marked active only during a read or write operation, however, this scenario is extremely unlikely because thousands of files would have to be accessed simultaneously for this situation to occur.

Cache size

In the following sections, we explain how Windows computes the size of the system cache, both virtually and physically. As with most calculations related to memory management, the size of the system cache depends on a number of factors.

Cache virtual size

On a 32-bit Windows system, the virtual size of the system cache is limited solely by the amount of kernel-mode virtual address space and the *SystemCacheLimit* registry key that can be optionally configured. (See Chapter 5 of Part 1 for more information on limiting the size of the kernel virtual address space.) This means that the cache size is capped by the 2-GB system address space, but it is typically significantly smaller because the system address space is shared with other resources, including system paged table entries (PTEs), nonpaged and paged pool, and page tables. The maximum virtual cache size is 64 TB on 64-bit Windows, and even in this case, the limit is still tied to the system address space size: in future systems that will support the 56-bit addressing mode, the limit will be 32 PB (petabytes).

Cache working set size

As mentioned earlier, one of the key differences in the design of the cache manager in Windows from that of other operating systems is the delegation of physical memory management to the global memory manager. Because of this, the existing code that handles working set expansion and trimming, as well as managing the modified and standby lists, is also used to control the size of the system cache, dynamically balancing demands for physical memory between processes and the operating system.

The system cache doesn't have its own working set but shares a single system set that includes cache data, paged pool, pageable kernel code, and pageable driver code. As explained in the section "System working sets" in Chapter 5 of Part 1, this single working set is called internally the *system cache working set* even though the system cache is just one of the components that contribute to it. For the purposes of this book, we refer to this working set simply as the *system working set*. Also explained in Chapter 5 is the fact that if the *LargeSystemCache* registry value is 1, the memory manager favors the system working set over that of processes running on the system.

Cache physical size

While the system working set includes the amount of physical memory that is mapped into views in the cache's virtual address space, it does not necessarily reflect the total amount of file data that is cached in physical memory. There can be a discrepancy between the two values because additional file data might be in the memory manager's standby or modified page lists.

Recall from Chapter 5 that during the course of working set trimming or page replacement, the memory manager can move dirty pages from a working set to either the standby list or the modified page list, depending on whether the page contains data that needs to be written to the paging file or another file before the page can be reused. If the memory manager didn't implement these lists, any time a process accessed data previously removed from its working set, the memory manager would

have to hard-fault it in from disk. Instead, if the accessed data is present on either of these lists, the memory manager simply soft-faults the page back into the process's working set. Thus, the lists serve as in-memory caches of data that are stored in the paging file, executable images, or data files. Thus, the total amount of file data cached on a system includes not only the system working set but the combined sizes of the standby and modified page lists as well.

An example illustrates how the cache manager can cause much more file data than that containable in the system working set to be cached in physical memory. Consider a system that acts as a dedicated file server. A client application accesses file data from across the network, while a server, such as the file server driver (%SystemRoot%\System32\Drivers\Srv2.sys, described later in this chapter), uses cache manager interfaces to read and write file data on behalf of the client. If the client reads through several thousand files of 1 MB each, the cache manager will have to start reusing views when it runs out of mapping space (and can't enlarge the VACB mapping area). For each file read thereafter, the cache manager unmaps views and remaps them for new files. When the cache manager unmaps a view, the memory manager doesn't discard the file data in the cache's working set that corresponds to the view; it moves the data to the standby list. In the absence of any other demand for physical memory, the standby list can consume almost all the physical memory that remains outside the system working set. In other words, virtually all the server's physical memory will be used to cache file data, as shown in Figure 11-4.

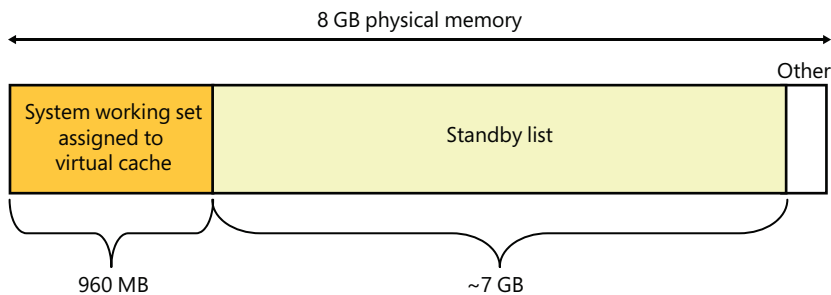

FIGURE 11-4 Example in which most of physical memory is being used by the file cache.

Because the total amount of file data cached includes the system working set, modified page list, and standby list—the sizes of which are all controlled by the memory manager—it is in a sense the real cache manager. The cache manager subsystem simply provides convenient interfaces for accessing file data through the memory manager. It also plays an important role with its read-ahead and write-behind policies in influencing what data the memory manager keeps present in physical memory, as well as with managing system virtual address views of the space.

To try to accurately reflect the total amount of file data that's cached on a system, Task Manager shows a value named "Cached" in its performance view that reflects the combined size of the system working set, standby list, and modified page list. Process Explorer, on the other hand, breaks up these values into Cache WS (system cache working set), Standby, and Modified. Figure 11-5 shows the system information view in Process Explorer and the Cache WS value in the Physical Memory area in the lower left of the figure, as well as the size of the standby and modified lists in the Paging Lists area near the middle of the figure. Note that the Cache value in Task Manager also includes the Paged WS,

Kernel WS, and Driver WS values shown in Process Explorer. When these values were chosen, the vast majority of System WS came from the Cache WS. This is no longer the case today, but the anachronism remains in Task Manager.

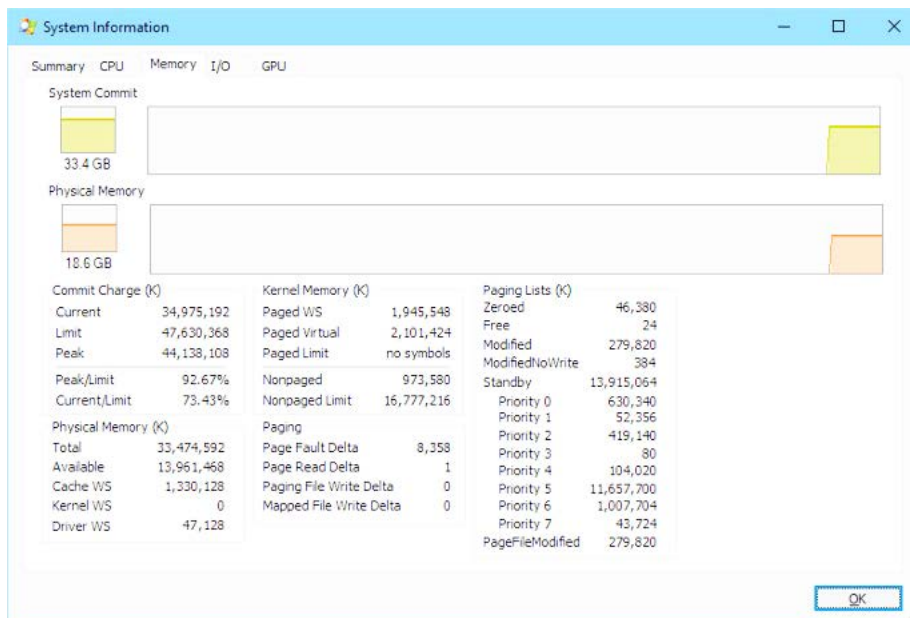

FIGURE 11-5 Process Explorer's System Information dialog box.

Cache data structures

The cache manager uses the following data structures to keep track of cached files:

- Each 256 KB slot in the system cache is described by a VACB.
- Each separately opened cached file has a private cache map, which contains information used to control read-ahead (discussed later in the chapter in the "Intelligent read-ahead" section).
- Each cached file has a single shared cache map structure, which points to slots in the system cache that contain mapped views of the file.

These structures and their relationships are described in the next sections.

Systemwide cache data structures

As previously described, the cache manager keeps track of the state of the views in the system cache by using an array of data structures called *virtual address control block (VACB) arrays* that are stored in nonpaged pool. On a 32-bit system, each VACB is 32 bytes in size and a VACB array is 128 KB, resulting

in 4,096 VACBs per array. On a 64-bit system, a VACB is 40 bytes, resulting in 3,276 VACBs per array. The cache manager allocates the initial VACB array during system initialization and links it into the system-wide list of VACB arrays called *CcVacbArrays*. Each VACB represents one 256 KB view in the system cache, as shown in Figure 11-6. The structure of a VACB is shown in Figure 11-7.

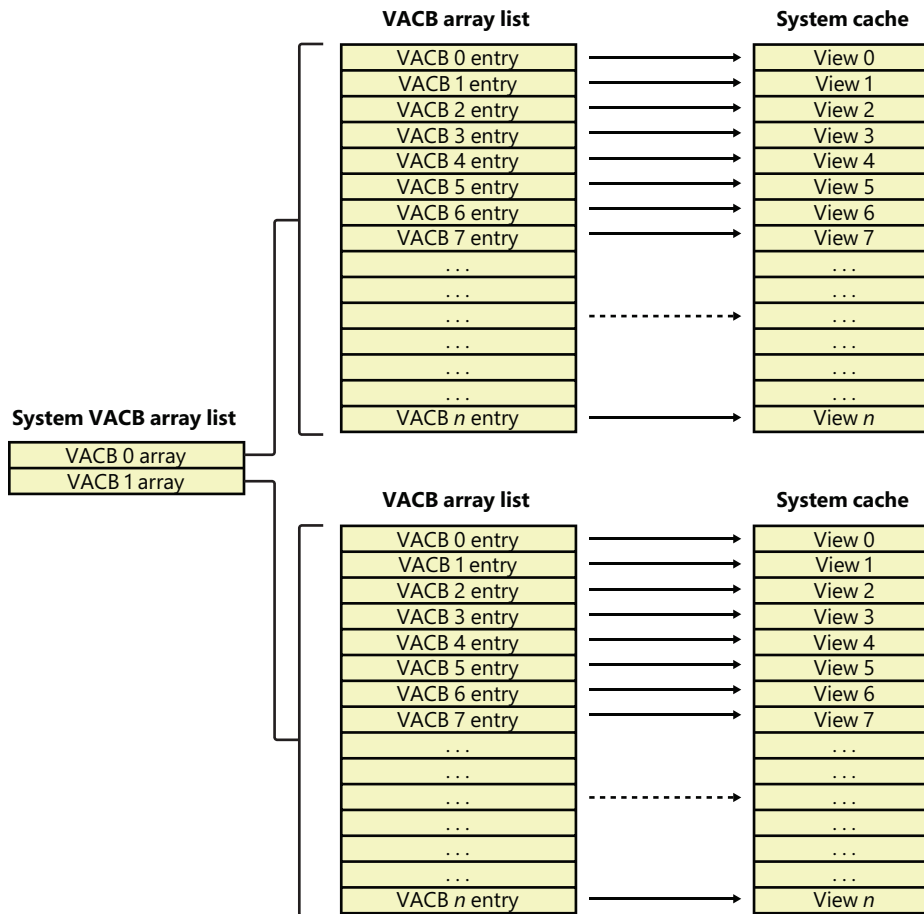

FIGURE 11-6 System VACB array.

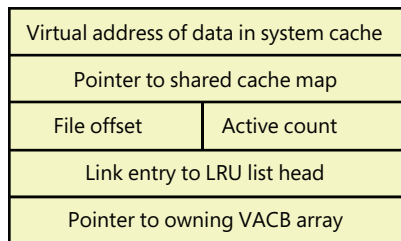

FIGURE 11-7 VACB data structure.

Additionally, each VACB array is composed of two kinds of VACB: *low priority mapping* VACBs and *high priority mapping* VACBs. The system allocates 64 initial high priority VACBs for each VACB array. High priority VACBs have the distinction of having their views preallocated from system address space. When the memory manager has no views to give to the cache manager at the time of mapping some data, and if the mapping request is marked as high priority, the cache manager will use one of the preallocated views present in a high priority VACB. It uses these high priority VACBs, for example, for critical file system metadata as well as for purging data from the cache. After high priority VACBs are gone, however, any operation requiring a VACB view will fail with insufficient resources. Typically, the mapping priority is set to the default of low, but by using the `PIN_HIGH_PRIORITY` flag when pinning (described later) cached data, file systems can request a high priority VACB to be used instead, if one is needed.

As you can see in Figure 11-7, the first field in a VACB is the virtual address of the data in the system cache. The second field is a pointer to the shared cache map structure, which identifies which file is cached. The third field identifies the offset within the file at which the view begins (always based on 256 KB granularity). Given this granularity, the bottom 16 bits of the file offset will always be zero, so those bits are reused to store the number of references to the view—that is, how many active reads or writes are accessing the view. The fourth field links the VACB into a list of least-recently-used (LRU) VACBs when the cache manager frees the VACB; the cache manager first checks this list when allocating a new VACB. Finally, the fifth field links this VACB to the VACB array header representing the array in which the VACB is stored.

During an I/O operation on a file, the file's VACB reference count is incremented, and then it's decremented when the I/O operation is over. When the reference count is nonzero, the VACB is *active*. For access to file system metadata, the active count represents how many file system drivers have the pages in that view locked into memory.

EXPERIMENT: Looking at VACBs and VACB statistics

The cache manager internally keeps track of various values that are useful to developers and support engineers when debugging crash dumps. All these debugging variables start with the `CcDbg` prefix, which makes it easy to see the whole list, thanks to the `x` command:

```
1: kd> x nt!*ccdbg*
fffff800`d052741c nt!CcDbgNumberOfFailedWorkQueueEntryAllocations = <no type information>
fffff800`d05276ec nt!CcDbgNumberOfNoopedReadAheads = <no type information>
fffff800`d05276e8 nt!CcDbgLsnLargerThanHint = <no type information>
fffff800`d05276e4 nt!CcDbgAdditionalPagesQueuedCount = <no type information>
fffff800`d0543370 nt!CcDbgFoundAsyncReadThreadListEmpty = <no type information>
fffff800`d054336c nt!CcDbgNumberOfCcUnmapInactiveViews = <no type information>
fffff800`d05276e0 nt!CcDbgSkippedReductions = <no type information>
fffff800`d0542e04 nt!CcDbgDisabledDAX = <no type information>
...
```

Some systems may show differences in variable names due to 32-bit versus 64-bit implementations. The exact variable names are irrelevant in this experiment—focus instead on the methodology that is explained. Using these variables and your knowledge of the VACB array header data structures, you can use the kernel debugger to list all the VACB array headers.

The `CcVacbArrays` variable is an array of pointers to VACB array headers, which you dereference to dump the contents of the `_VACB_ARRAY_HEADERS`. First, obtain the highest array index:

```
1: kd> dd nt!CcVacbArraysHighestUsedIndex 11
fffff800`d0529c1c 00000000
```

And now you can dereference each index until the maximum index. On this system (and this is the norm), the highest index is 0, which means there's only one header to dereference:

```
1: kd> ?? (*(nt!_VACB_ARRAY_HEADER**))@(nt!CcVacbArrays))[0]
struct _VACB_ARRAY_HEADER * 0xfffffc40d`221cb000
+0x000 VacbArrayIndex      : 0
+0x004 MappingCount        : 0x302
+0x008 HighestMappedIndex  : 0x301
+0x00c Reserved            : 0
```

If there were more, you could change the array index at the end of the command with a higher number, until you reach the highest used index. The output shows that the system has only one VACB array with 770 (0x302) active VACBs.

Finally, the `CcNumberOfFreeVacbs` variable stores the number of VACBs on the free VACB list. Dumping this variable on the system used for the experiment results in 2,506 (0x9ca):

```
1: kd> dd nt!CcNumberOfFreeVacbs 11
fffff800`d0527318 000009ca
```

As expected, the sum of the free (0x9ca—2,506 decimal) and active VACBs (0x302—770 decimal) on a 64-bit system with one VACB array equals 3,276, the number of VACBs in one VACB array. If the system were to run out of free VACBs, the cache manager would try to allocate a new VACB array. Because of the volatile nature of this experiment, your system may create and/or free additional VACBs between the two steps (dumping the active and then the free VACBs). This might cause your total of free and active VACBs to not match exactly 3,276. Try quickly repeating the experiment a couple of times if this happens, although you may never get stable numbers, especially if there is lots of file system activity on the system.

Per-file cache data structures

Each open handle to a file has a corresponding file object. (File objects are explained in detail in Chapter 6 of Part 1, “I/O system.”) If the file is cached, the file object points to a *private cache map* structure that contains the location of the last two reads so that the cache manager can perform intelligent read-ahead (described later, in the section “Intelligent read-ahead”). In addition, all the private cache maps for open instances of a file are linked together.

Each cached file (as opposed to file object) has a *shared cache map* structure that describes the state of the cached file, including the partition to which it belongs, its size, and its valid data length. (The function of the valid data length field is explained in the section “Write-back caching and lazy writing.”) The shared cache map also points to the *section object* (maintained by the memory manager and which describes the file's mapping into virtual memory), the list of private cache maps associated with that

file, and any VACBs that describe currently mapped views of the file in the system cache. (See Chapter 5 of Part 1 for more about section object pointers.) All the opened shared cache maps for different files are linked in a global linked list maintained in the cache manager's partition data structure. The relationships among these per-file cache data structures are illustrated in Figure 11-8.

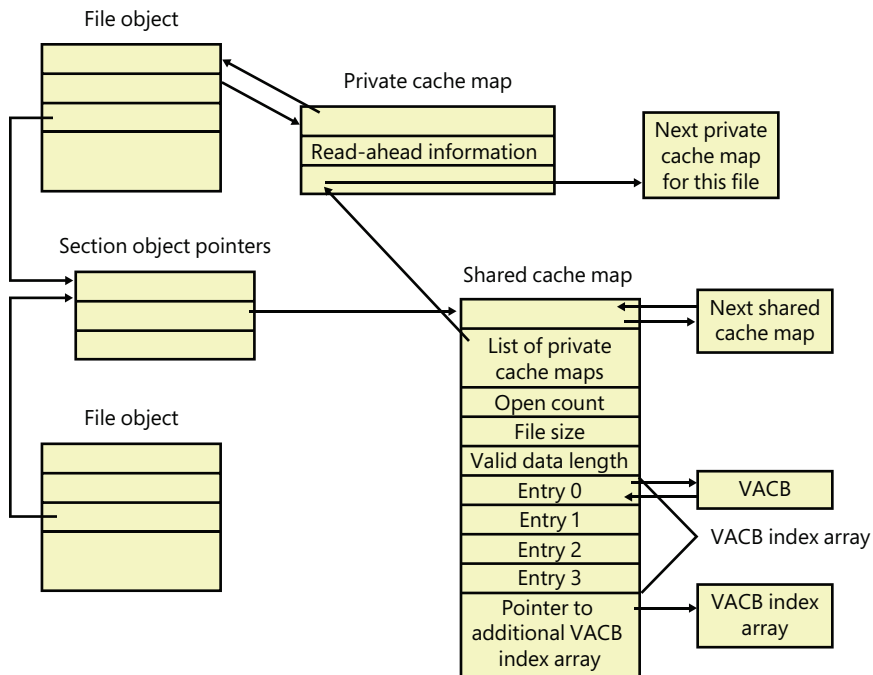

FIGURE 11-8 Per-file cache data structures.

When asked to read from a particular file, the cache manager must determine the answers to two questions:

1. Is the file in the cache?
2. If so, which VACB, if any, refers to the requested location?

In other words, the cache manager must find out whether a view of the file at the desired address is mapped into the system cache. If no VACB contains the desired file offset, the requested data isn't currently mapped into the system cache.

To keep track of which views for a given file are mapped into the system cache, the cache manager maintains an array of pointers to VACBs, which is known as the *VACB index array*. The first entry in the VACB index array refers to the first 256 KB of the file, the second entry to the second 256 KB, and so on. The diagram in Figure 11-9 shows four different sections from three different files that are currently mapped into the system cache.

When a process accesses a particular file in a given location, the cache manager looks in the appropriate entry in the file's VACB index array to see whether the requested data has been mapped into the cache. If the array entry is nonzero (and hence contains a pointer to a VACB), the area of the file being referenced is in the cache. The VACB, in turn, points to the location in the system cache where the view of the file is mapped. If the entry is zero, the cache manager must find a free slot in the system cache (and therefore a free VACB) to map the required view.

As a size optimization, the shared cache map contains a VACB index array that is four entries in size. Because each VACB describes 256 KB, the entries in this small, fixed-size index array can point to VACB array entries that together describe a file of up to 1 MB. If a file is larger than 1 MB, a separate VACB index array is allocated from nonpaged pool, based on the size of the file divided by 256 KB and rounded up in the case of a remainder. The shared cache map then points to this separate structure.

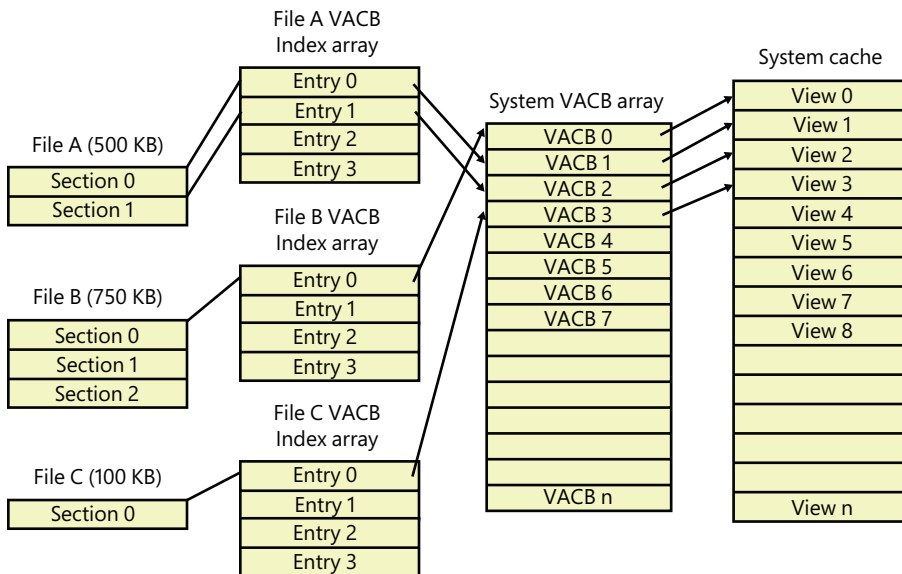

FIGURE 11-9 VACB index arrays.

As a further optimization, the VACB index array allocated from nonpaged pool becomes a sparse multilevel index array if the file is larger than 32 MB, where each index array consists of 128 entries. You can calculate the number of levels required for a file with the following formula:

$$(Number\ of\ bits\ required\ to\ represent\ file\ size - 18) / 7$$

Round up the result of the equation to the next whole number. The value 18 in the equation comes from the fact that a VACB represents 256 KB, and 256 KB is 2^{18} . The value 7 comes from the fact that each level in the array has 128 entries and 2^7 is 128. Thus, a file that has a size that is the maximum that can be described with 63 bits (the largest size the cache manager supports) would require only seven levels. The array is sparse because the only branches that the cache manager allocates are ones for which there are active views at the lowest-level index array. Figure 11-10 shows an example of a multi-level VACB array for a sparse file that is large enough to require three levels.

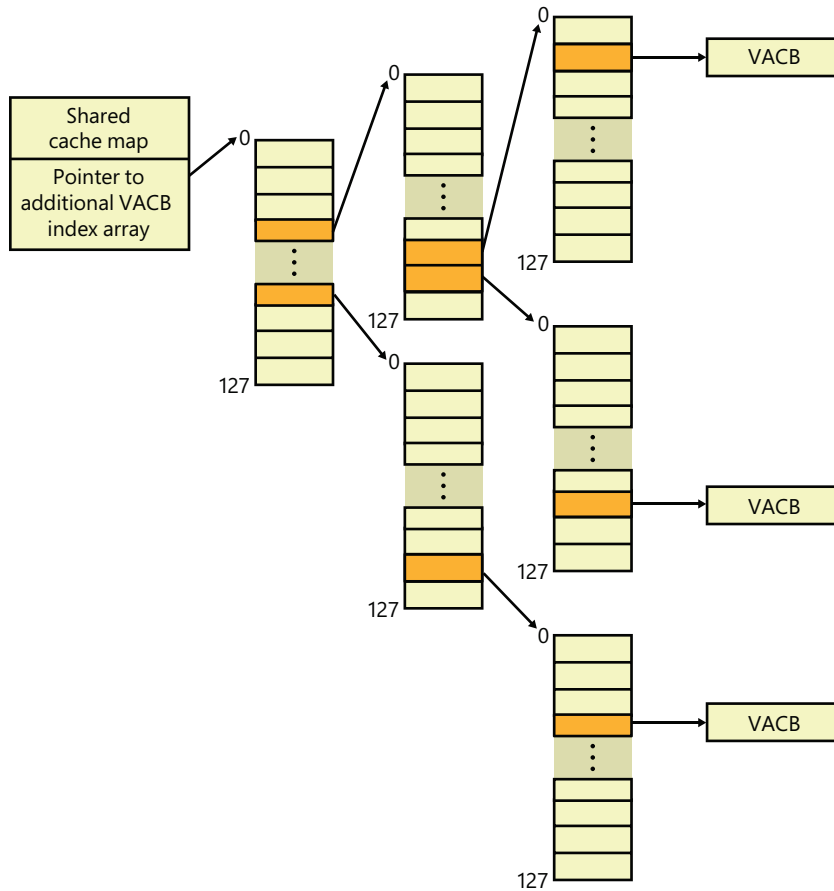

FIGURE 11-10 Multilevel VACB arrays.

This scheme is required to efficiently handle sparse files that might have extremely large file sizes with only a small fraction of valid data because only enough of the array is allocated to handle the currently mapped views of a file. For example, a 32-GB sparse file for which only 256 KB is mapped into the cache’s virtual address space would require a VACB array with three allocated index arrays because only one branch of the array has a mapping and a 32-GB file requires a three-level array. If the cache manager didn’t use the multilevel VACB index array optimization for this file, it would have to allocate a VACB index array with 128,000 entries, or the equivalent of 1,000 VACB index arrays.

File system interfaces

The first time a file’s data is accessed for a cached read or write operation, the file system driver is responsible for determining whether some part of the file is mapped in the system cache. If it’s not, the file system driver must call the *CcInitializeCacheMap* function to set up the per-file data structures described in the preceding section.

Once a file is set up for cached access, the file system driver calls one of several functions to access the data in the file. There are three primary methods for accessing cached data, each intended for a specific situation:

- The copy method copies user data between cache buffers in system space and a process buffer in user space.
- The mapping and pinning method uses virtual addresses to read and write data directly from and to cache buffers.
- The physical memory access method uses physical addresses to read and write data directly from and to cache buffers.

File system drivers must provide two versions of the file read operation—cached and noncached—to prevent an infinite loop when the memory manager processes a page fault. When the memory manager resolves a page fault by calling the file system to retrieve data from the file (via the device driver, of course), it must specify this as a paging read operation by setting the “no cache” and “paging IO” flags in the IRP.

Figure 11-11 illustrates the typical interactions between the cache manager, the memory manager, and file system drivers in response to user read or write file I/O. The cache manager is invoked by a file system through the copy interfaces (the *CcCopyRead* and *CcCopyWrite* paths). To process a *CcFastCopyRead* or *CcCopyRead* read, for example, the cache manager creates a view in the cache to map a portion of the file being read and reads the file data into the user buffer by copying from the view. The copy operation generates page faults as it accesses each previously invalid page in the view, and in response the memory manager initiates noncached I/O into the file system driver to retrieve the data corresponding to the part of the file mapped to the page that faulted.

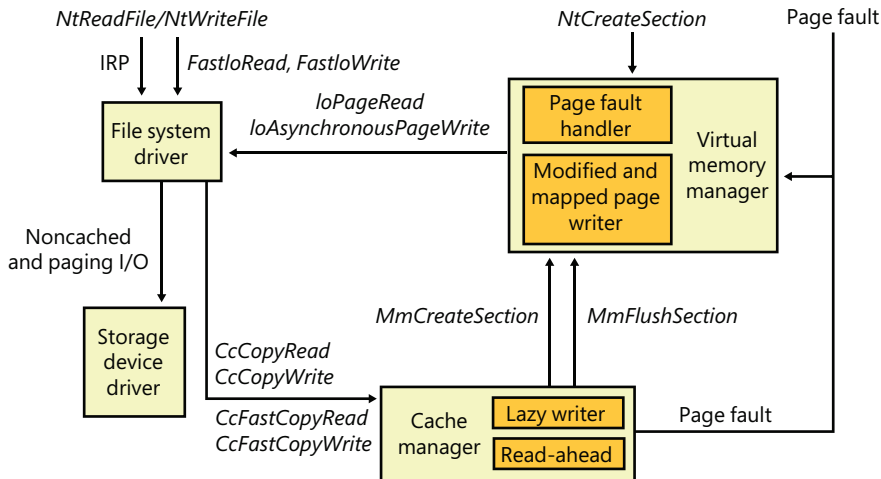

FIGURE 11-11 File system interaction with cache and memory managers.

The next three sections explain these cache access mechanisms, their purpose, and how they’re used.

Copying to and from the cache

Because the system cache is in system space, it's mapped into the address space of every process. As with all system space pages, however, cache pages aren't accessible from user mode because that would be a potential security hole. (For example, a process might not have the rights to read a file whose data is currently contained in some part of the system cache.) Thus, user application file reads and writes to cached files must be serviced by kernel-mode routines that copy data between the cache's buffers in system space and the application's buffers residing in the process address space.

Caching with the mapping and pinning interfaces

Just as user applications read and write data in files on a disk, file system drivers need to read and write the data that describes the files themselves (the metadata, or volume structure data). Because the file system drivers run in kernel mode, however, they could, if the cache manager were properly informed, modify data directly in the system cache. To permit this optimization, the cache manager provides functions that permit the file system drivers to find where in virtual memory the file system metadata resides, thus allowing direct modification without the use of intermediary buffers.

If a file system driver needs to read file system metadata in the cache, it calls the cache manager's mapping interface to obtain the virtual address of the desired data. The cache manager touches all the requested pages to bring them into memory and then returns control to the file system driver. The file system driver can then access the data directly.

If the file system driver needs to modify cache pages, it calls the cache manager's pinning services, which keep the pages active in virtual memory so that they can't be reclaimed. The pages aren't actually locked into memory (such as when a device driver locks pages for direct memory access transfers). Most of the time, a file system driver will mark its metadata stream as no write, which instructs the memory manager's mapped page writer (explained in Chapter 5 of Part 1) to not write the pages to disk until explicitly told to do so. When the file system driver unpins (releases) them, the cache manager releases its resources so that it can lazily flush any changes to disk and release the cache view that the metadata occupied.

The mapping and pinning interfaces solve one thorny problem of implementing a file system: buffer management. Without directly manipulating cached metadata, a file system must predict the maximum number of buffers it will need when updating a volume's structure. By allowing the file system to access and update its metadata directly in the cache, the cache manager eliminates the need for buffers, simply updating the volume structure in the virtual memory the memory manager provides. The only limitation the file system encounters is the amount of available memory.

Caching with the direct memory access interfaces

In addition to the mapping and pinning interfaces used to access metadata directly in the cache, the cache manager provides a third interface to cached data: *direct memory access* (DMA). The DMA functions are used to read from or write to cache pages without intervening buffers, such as when a network file system is doing a transfer over the network.

The DMA interface returns to the file system the physical addresses of cached user data (rather than the virtual addresses, which the mapping and pinning interfaces return), which can then be used to transfer data directly from physical memory to a network device. Although small amounts of data (1 KB to 2 KB) can use the usual buffer-based copying interfaces, for larger transfers the DMA interface can result in significant performance improvements for a network server processing file requests from remote systems. To describe these references to physical memory, a *memory descriptor list* (MDL) is used. (MDLs are introduced in Chapter 5 of Part 1.)

Fast I/O

Whenever possible, reads and writes to cached files are handled by a high-speed mechanism named *fast I/O*. Fast I/O is a means of reading or writing a cached file without going through the work of generating an IRP. With fast I/O, the I/O manager calls the file system driver's fast I/O routine to see whether I/O can be satisfied directly from the cache manager without generating an IRP.

Because the cache manager is architected on top of the virtual memory subsystem, file system drivers can use the cache manager to access file data simply by copying to or from pages mapped to the actual file being referenced without going through the overhead of generating an IRP.

Fast I/O doesn't always occur. For example, the first read or write to a file requires setting up the file for caching (mapping the file into the cache and setting up the cache data structures, as explained earlier in the section "Cache data structures"). Also, if the caller specified an asynchronous read or write, fast I/O isn't used because the caller might be stalled during paging I/O operations required to satisfy the buffer copy to or from the system cache and thus not really providing the requested asynchronous I/O operation. But even on a synchronous I/O operation, the file system driver might decide that it can't process the I/O operation by using the fast I/O mechanism—say, for example, if the file in question has a locked range of bytes (as a result of calls to the Windows *LockFile* and *UnlockFile* functions). Because the cache manager doesn't know what parts of which files are locked, the file system driver must check the validity of the read or write, which requires generating an IRP. The decision tree for fast I/O is shown in Figure 11-12.

These steps are involved in servicing a read or a write with fast I/O:

1. A thread performs a read or write operation.
2. If the file is cached and the I/O is synchronous, the request passes to the fast I/O entry point of the file system driver stack. If the file isn't cached, the file system driver sets up the file for caching so that the next time, fast I/O can be used to satisfy a read or write request.
3. If the file system driver's fast I/O routine determines that fast I/O is possible, it calls the cache manager's read or write routine to access the file data directly in the cache. (If fast I/O isn't possible, the file system driver returns to the I/O system, which then generates an IRP for the I/O and eventually calls the file system's regular read routine.)
4. The cache manager translates the supplied file offset into a virtual address in the cache.

5. For reads, the cache manager copies the data from the cache into the buffer of the process requesting it; for writes, it copies the data from the buffer to the cache.
6. One of the following actions occurs:
 - For reads where *FILE_FLAG_RANDOM_ACCESS* wasn't specified when the file was opened, the read-ahead information in the caller's private cache map is updated. Read-ahead may also be queued for files for which the *FO_RANDOM_ACCESS* flag is not specified.
 - For writes, the dirty bit of any modified page in the cache is set so that the lazy writer will know to flush it to disk.
 - For write-through files, any modifications are flushed to disk.

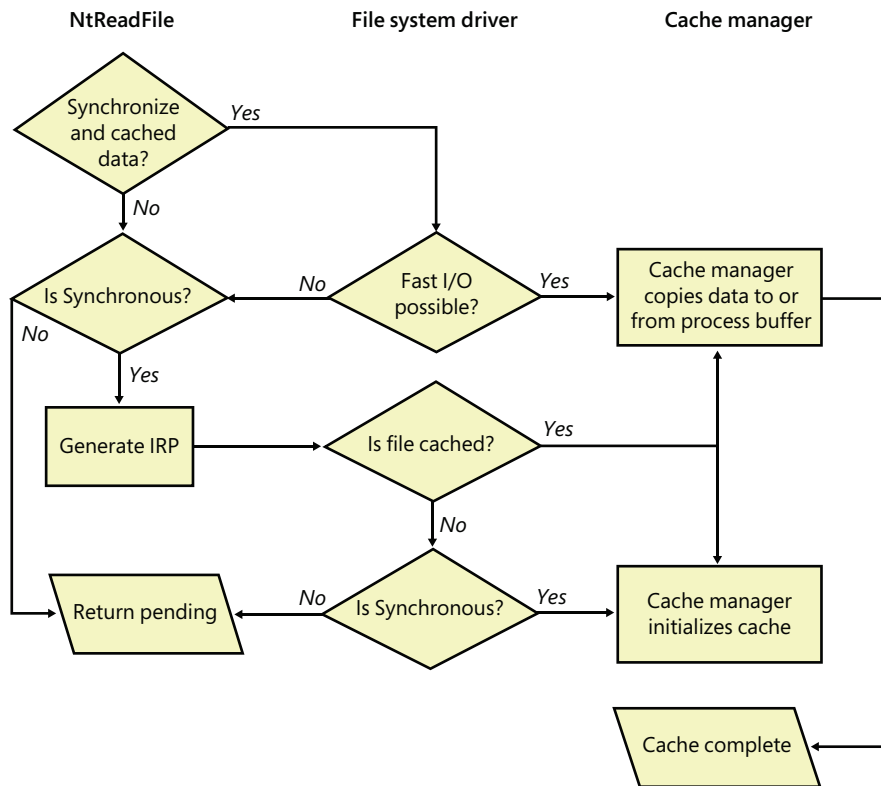

FIGURE 11-12 Fast I/O decision tree.

Read-ahead and write-behind

In this section, you'll see how the cache manager implements reading and writing file data on behalf of file system drivers. Keep in mind that the cache manager is involved in file I/O only when a file is opened without the *FILE_FLAG_NO_BUFFERING* flag and then read from or written to using the Windows I/O

functions (for example, using the Windows *ReadFile* and *WriteFile* functions). Mapped files don't go through the cache manager, nor do files opened with the *FILE_FLAG_NO_BUFFERING* flag set.



Note When an application uses the *FILE_FLAG_NO_BUFFERING* flag to open a file, its file I/O must start at device-aligned offsets and be of sizes that are a multiple of the alignment size; its input and output buffers must also be device-aligned virtual addresses. For file systems, this usually corresponds to the sector size (4,096 bytes on NTFS, typically, and 2,048 bytes on CDFS). One of the benefits of the cache manager, apart from the actual caching performance, is the fact that it performs intermediate buffering to allow arbitrarily aligned and sized I/O.

Intelligent read-ahead

The cache manager uses the principle of spatial locality to perform *intelligent read-ahead* by predicting what data the calling process is likely to read next based on the data that it's reading currently. Because the system cache is based on virtual addresses, which are contiguous for a particular file, it doesn't matter whether they're juxtaposed in physical memory. File read-ahead for logical block caching is more complex and requires tight cooperation between file system drivers and the block cache because that cache system is based on the relative positions of the accessed data on the disk, and, of course, files aren't necessarily stored contiguously on disk. You can examine read-ahead activity by using the Cache: Read Aheads/sec performance counter or the *CcReadAheadIos* system variable.

Reading the next block of a file that is being accessed sequentially provides an obvious performance improvement, with the disadvantage that it will cause head seeks. To extend read-ahead benefits to cases of stridden data accesses (both forward and backward through a file), the cache manager maintains a history of the last two read requests in the private cache map for the file handle being accessed, a method known as *asynchronous read-ahead with history*. If a pattern can be determined from the caller's apparently random reads, the cache manager extrapolates it. For example, if the caller reads page 4,000 and then page 3,000, the cache manager assumes that the next page the caller will require is page 2,000 and prereads it.



Note Although a caller must issue a minimum of three read operations to establish a predictable sequence, only two are stored in the private cache map.

To make read-ahead even more efficient, the Win32 *CreateFile* function provides a flag indicating forward sequential file access: *FILE_FLAG_SEQUENTIAL_SCAN*. If this flag is set, the cache manager doesn't keep a read history for the caller for prediction but instead performs sequential read-ahead. However, as the file is read into the cache's working set, the cache manager unmaps views of the file that are no longer active and, if they are unmodified, directs the memory manager to place the pages belonging to the unmapped views at the front of the standby list so that they will be quickly reused. It also reads ahead two times as much data (2 MB instead of 1 MB, for example). As the caller continues reading, the cache manager prereads additional blocks of data, always staying about one read (of the size of the current read) ahead of the caller.

The cache manager's read-ahead is asynchronous because it's performed in a thread separate from the caller's thread and proceeds concurrently with the caller's execution. When called to retrieve cached data, the cache manager first accesses the requested virtual page to satisfy the request and then queues an additional I/O request to retrieve additional data to a system worker thread. The worker thread then executes in the background, reading additional data in anticipation of the caller's next read request. The pre-read pages are faulted into memory while the program continues executing so that when the caller requests the data it's already in memory.

For applications that have no predictable read pattern, the `FILE_FLAG_RANDOM_ACCESS` flag can be specified when the `CreateFile` function is called. This flag instructs the cache manager not to attempt to predict where the application is reading next and thus disables read-ahead. The flag also stops the cache manager from aggressively unmapping views of the file as the file is accessed so as to minimize the mapping/unmapping activity for the file when the application revisits portions of the file.

Read-ahead enhancements

Windows 8.1 introduced some enhancements to the cache manager read-ahead functionality. File system drivers and network redirectors can decide the size and growth for the intelligent read-ahead with the `CcSetReadAheadGranularityEx` API function. The cache manager client can decide the following:

- **Read-ahead granularity** Sets the minimum read-ahead unit size and the end file-offset of the next read-ahead. The cache manager sets the default granularity to 4 Kbytes (the size of a memory page), but every file system sets this value in a different way (NTFS, for example, sets the cache granularity to 64 Kbytes).

Figure 11-13 shows an example of read-ahead on a 200 Kbyte-sized file, where the cache granularity has been set to 64 KB. If the user requests a nonaligned 1 KB read at offset 0x10800, and if a sequential read has already been detected, the intelligent read-ahead will emit an I/O that encompasses the 64 KB of data from offset 0x10000 to 0x20000. If there were already more than two sequential reads, the cache manager emits another supplementary read from offset 0x20000 to offset 0x30000 (192 Kbytes).

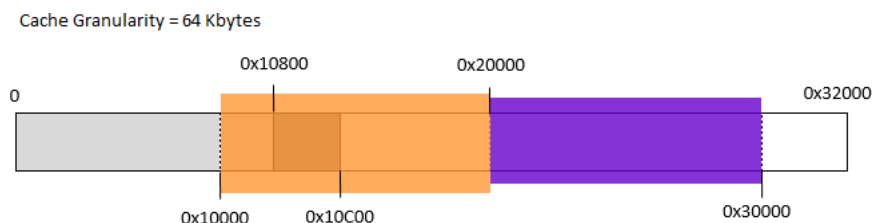

FIGURE 11-13 Read-ahead on a 200 KB file, with granularity set to 64KB.

- **Pipeline size** For some remote file system drivers, it may make sense to split large read-ahead I/Os into smaller chunks, which will be emitted in parallel by the cache manager worker threads. A network file system can achieve a substantial better throughput using this technique.

- **Read-ahead aggressiveness** File system drivers can specify the percentage used by the cache manager to decide how to increase the read-ahead size after the detection of a third sequential read. For example, let's assume that an application is reading a big file using a 1 Mbyte I/O size. After the tenth read, the application has already read 10 Mbytes (the cache manager may have already prefetched some of them). The intelligent read-ahead now decides by how much to grow the read-ahead I/O size. If the file system has specified 60% of growth, the formula used is the following:

(Number of sequential reads * Size of last read) * (Growth percentage / 100)

So, this means that the next read-ahead size is 6 MB (instead of being 2 MB, assuming that the granularity is 64 KB and the I/O size is 1 MB). The default growth percentage is 50% if not modified by any cache manager client.

Write-back caching and lazy writing

The cache manager implements a write-back cache with lazy write. This means that data written to files is first stored in memory in cache pages and then written to disk later. Thus, write operations are allowed to accumulate for a short time and are then flushed to disk all at once, reducing the overall number of disk I/O operations.

The cache manager must explicitly call the memory manager to flush cache pages because otherwise the memory manager writes memory contents to disk only when demand for physical memory exceeds supply, as is appropriate for volatile data. Cached file data, however, represents nonvolatile disk data. If a process modifies cached data, the user expects the contents to be reflected on disk in a timely manner.

Additionally, the cache manager has the ability to veto the memory manager's mapped writer thread. Since the modified list (see Chapter 5 of Part 1 for more information) is not sorted in logical block address (LBA) order, the cache manager's attempts to cluster pages for larger sequential I/Os to the disk are not always successful and actually cause repeated seeks. To combat this effect, the cache manager has the ability to aggressively veto the mapped writer thread and stream out writes in virtual byte offset (VBO) order, which is much closer to the LBA order on disk. Since the cache manager now owns these writes, it can also apply its own scheduling and throttling algorithms to prefer read-ahead over write-behind and impact the system less.

The decision about how often to flush the cache is an important one. If the cache is flushed too frequently, system performance will be slowed by unnecessary I/O. If the cache is flushed too rarely, you risk losing modified file data in the cases of a system failure (a loss especially irritating to users who know that they asked the application to save the changes) and running out of physical memory (because it's being used by an excess of modified pages).

To balance these concerns, the cache manager's *lazy writer scan* function executes on a system worker thread once per second. The lazy writer scan has different duties:

- Checks the number of average available pages and dirty pages (that belongs to the current partition) and updates the dirty page threshold's bottom and the top limits accordingly. The threshold itself is updated too, primarily based on the total number of dirty pages written in the previous cycle (see the following paragraphs for further details). It sleeps if there are no dirty pages to write.
- Calculates the number of dirty pages to write to disk through the *CcCalculatePagesToWrite* internal routine. If the number of dirty pages is more than 256 (1 MB of data), the cache manager queues one-eighth of the total dirty pages to be flushed to disk. If the rate at which dirty pages are being produced is greater than the amount the lazy writer had determined it should write, the lazy writer writes an additional number of dirty pages that it calculates are necessary to match that rate.
- Cycles between each shared cache map (which are stored in a linked list belonging to the current partition), and, using the internal *CcShouldLazyWriteCacheMap* routine, determines if the current file described by the shared cache map needs to be flushed to disk. There are different reasons why a file shouldn't be flushed to disk: for example, an I/O could have been already initialized by another thread, the file could be a temporary file, or, more simply, the cache map might not have any dirty pages. In case the routine determined that the file should be flushed out, the lazy writer scan checks whether there are still enough available pages to write, and, if so, posts a work item to the cache manager system worker threads.



Note The lazy writer scan uses some exceptions while deciding the number of dirty pages mapped by a particular shared cache map to write (it doesn't always write all the dirty pages of a file): If the target file is a metadata stream with more than 256 KB of dirty pages, the cache manager writes only one-eighth of its total pages. Another exception is used for files that have more dirty pages than the total number of pages that the lazy writer scan can flush.

Lazy writer system worker threads from the systemwide critical worker thread pool actually perform the I/O operations. The lazy writer is also aware of when the memory manager's mapped page writer is already performing a flush. In these cases, it delays its write-back capabilities to the same stream to avoid a situation where two flushers are writing to the same file.



Note The cache manager provides a means for file system drivers to track when and how much data has been written to a file. After the lazy writer flushes dirty pages to the disk, the cache manager notifies the file system, instructing it to update its view of the valid data length for the file. (The cache manager and file systems separately track in memory the valid data length for a file.)

EXPERIMENT: Watching the cache manager in action

In this experiment, we use Process Monitor to view the underlying file system activity, including cache manager read-ahead and write-behind, when Windows Explorer copies a large file (in this example, a DVD image) from one local directory to another.

First, configure Process Monitor's filter to include the source and destination file paths, the Explorer.exe and System processes, and the ReadFile and WriteFile operations. In this example, the C:\Users\Andrea\Documents\Windows_10_RS3.iso file was copied to C:\ISOs\ Windows_10_RS3.iso, so the filter is configured as follows:

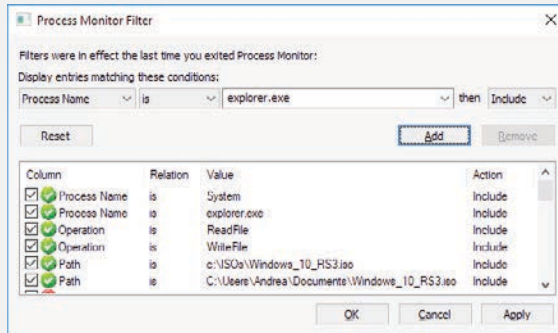

You should see a Process Monitor trace like the one shown here after you copy the file:

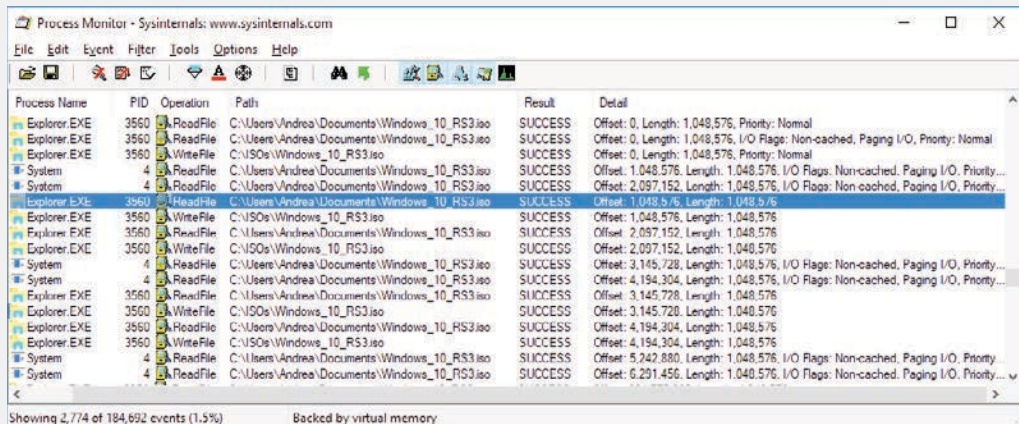

The first few entries show the initial I/O processing performed by the copy engine and the first cache manager operations. Here are some of the things that you can see:

- The initial 1 MB cached read from Explorer at the first entry. The size of this read depends on an internal matrix calculation based on the file size and can vary from 128 KB to 1 MB. Because this file was large, the copy engine chose 1 MB.

- The 1-MB read is followed by another 1-MB noncached read. Noncached reads typically indicate activity due to page faults or cache manager access. A closer look at the stack trace for these events, which you can see by double-clicking an entry and choosing the Stack tab, reveals that indeed the *CcCopyRead* cache manager routine, which is called by the NTFS driver's read routine, causes the memory manager to fault the source data into physical memory:

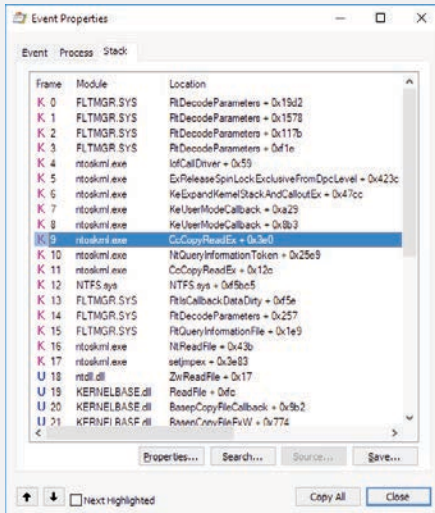

- After this 1-MB page fault I/O, the cache manager's read-ahead mechanism starts reading the file, which includes the System process's subsequent noncached 1-MB read at the 1-MB offset. Because of the file size and Explorer's read I/O sizes, the cache manager chose 1 MB as the optimal read-ahead size. The stack trace for one of the read-ahead operations, shown next, confirms that one of the cache manager's worker threads is performing the read-ahead.

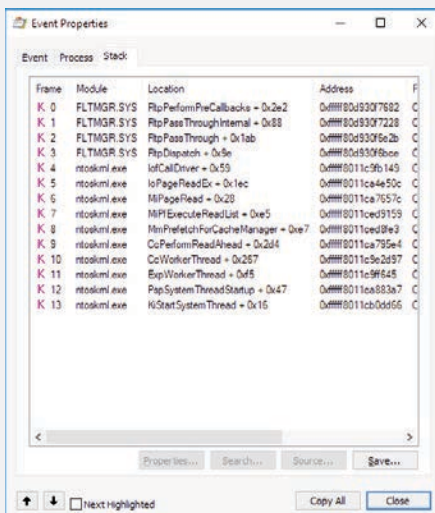

After this point, Explorer's 1-MB reads aren't followed by page faults, because the read-ahead thread stays ahead of Explorer, prefetching the file data with its 1-MB noncached reads. However, every once in a while, the read-ahead thread is not able to pick up enough data in time, and clustered page faults do occur, which appear as Synchronous Paging I/O.

Process Monitor - Sysinternals: www.sysinternals.com

Process Name	PID	Operation	Path	Result	Detail
Explorer.EXE	3560	WriteFile	C:\ISOs\Windows_10_RS3.iso	SUCCESS	Offset: 61,955,984. Length: 1,048,576
Explorer.EXE	3560	ReadFile	C:\Users\Andrea\Documents\Windows_10_RS3.iso	SUCCESS	Offset: 62,914,560. Length: 1,048,576
Explorer.EXE	3560	WriteFile	C:\ISOs\Windows_10_RS3.iso	SUCCESS	Offset: 62,914,560. Length: 1,048,576
System	4	ReadFile	C:\Users\Andrea\Documents\Windows_10_RS3.iso	SUCCESS	Offset: 63,963,136. Length: 1,048,576. I/O Flags: Non-cached, Paging I/O, Priority...
Explorer.EXE	3560	ReadFile	C:\Users\Andrea\Documents\Windows_10_RS3.iso	SUCCESS	Offset: 63,963,136. Length: 1,048,576
System	4	ReadFile	C:\Users\Andrea\Documents\Windows_10_RS3.iso	SUCCESS	Offset: 65,011,712. Length: 1,048,576. I/O Flags: Non-cached, Paging I/O, Priority...
System	4	ReadFile	C:\Users\Andrea\Documents\Windows_10_RS3.iso	SUCCESS	Offset: 66,060,288. Length: 1,048,576. I/O Flags: Non-cached, Paging I/O, Priority...
System	4	ReadFile	C:\Users\Andrea\Documents\Windows_10_RS3.iso	SUCCESS	Offset: 67,108,864. Length: 1,048,576. I/O Flags: Non-cached, Paging I/O, Priority...
Explorer.EXE	3560	WriteFile	C:\ISOs\Windows_10_RS3.iso	SUCCESS	Offset: 68,157,440. Length: 1,048,576
Explorer.EXE	3560	ReadFile	C:\Users\Andrea\Documents\Windows_10_RS3.iso	SUCCESS	Offset: 69,206,016. Length: 1,048,576
Explorer.EXE	3560	WriteFile	C:\ISOs\Windows_10_RS3.iso	SUCCESS	Offset: 70,254,592. Length: 1,048,576
Explorer.EXE	3560	ReadFile	C:\Users\Andrea\Documents\Windows_10_RS3.iso	SUCCESS	Offset: 71,303,168. Length: 1,048,576
Explorer.EXE	3560	WriteFile	C:\ISOs\Windows_10_RS3.iso	SUCCESS	Offset: 72,351,744. Length: 1,048,576
Explorer.EXE	3560	ReadFile	C:\Users\Andrea\Documents\Windows_10_RS3.iso	SUCCESS	Offset: 73,400,320. Length: 1,048,576. I/O Flags: Non-cached, Paging I/O, Priority...
Explorer.EXE	3560	WriteFile	C:\ISOs\Windows_10_RS3.iso	SUCCESS	Offset: 74,448,896. Length: 1,048,576

Showing 2,774 of 184,692 events (1.5%) Backed by virtual memory

If you look at the stack for these entries, you'll see that instead of *MmPrefetchForCacheManager*, the *MmAccessFault/MilssueHardFault* routines are called.

As soon as it starts reading, Explorer also starts performing writes to the destination file. These are sequential, cached 1-MB writes. After about 124 MB of reads, the first *WriteFile* operation from the System process occurs, shown here:

Process Monitor - Sysinternals: www.sysinternals.com

Process Name	PID	Operation	Path	Result	Detail
Explorer.EXE	3560	WriteFile	C:\ISOs\Windows_10_RS3.iso	SUCCESS	Offset: 123,731,968. Length: 1,048,576
Explorer.EXE	3560	ReadFile	C:\Users\Andrea\Documents\Windows_10_RS3.iso	SUCCESS	Offset: 124,780,544. Length: 1,048,576
Explorer.EXE	3560	WriteFile	C:\ISOs\Windows_10_RS3.iso	SUCCESS	Offset: 124,780,544. Length: 1,048,576
Explorer.EXE	3560	ReadFile	C:\Users\Andrea\Documents\Windows_10_RS3.iso	SUCCESS	Offset: 125,829,120. Length: 1,048,576
Explorer.EXE	3560	ReadFile	C:\Users\Andrea\Documents\Windows_10_RS3.iso	SUCCESS	Offset: 125,829,120. Length: 73,728. I/O Flags: Non-cached, Paging I/O, Priority...
System	4	WriteFile	C:\ISOs\Windows_10_RS3.iso	SUCCESS	Offset: 1,048,576. Length: 1,048,576. I/O Flags: Non-cached, Paging I/O, Synchron...
System	4	WriteFile	C:\ISOs\Windows_10_RS3.iso	SUCCESS	Offset: 2,097,152. Length: 1,048,576. I/O Flags: Non-cached, Paging I/O, Synchron...
System	4	WriteFile	C:\ISOs\Windows_10_RS3.iso	SUCCESS	Offset: 3,145,728. Length: 1,048,576. I/O Flags: Non-cached, Paging I/O, Synchron...
System	4	WriteFile	C:\ISOs\Windows_10_RS3.iso	SUCCESS	Offset: 4,194,304. Length: 1,048,576. I/O Flags: Non-cached, Paging I/O, Synchron...
System	4	WriteFile	C:\ISOs\Windows_10_RS3.iso	SUCCESS	Offset: 5,242,880. Length: 1,048,576. I/O Flags: Non-cached, Paging I/O, Synchron...
System	4	WriteFile	C:\ISOs\Windows_10_RS3.iso	SUCCESS	Offset: 6,291,456. Length: 1,048,576. I/O Flags: Non-cached, Paging I/O, Synchron...
System	4	WriteFile	C:\ISOs\Windows_10_RS3.iso	SUCCESS	Offset: 7,340,032. Length: 1,048,576. I/O Flags: Non-cached, Paging I/O, Synchron...
System	4	WriteFile	C:\ISOs\Windows_10_RS3.iso	SUCCESS	Offset: 8,388,608. Length: 1,048,576. I/O Flags: Non-cached, Paging I/O, Synchron...
System	4	WriteFile	C:\ISOs\Windows_10_RS3.iso	SUCCESS	Offset: 9,437,184. Length: 1,048,576. I/O Flags: Non-cached, Paging I/O, Synchron...
System	4	WriteFile	C:\ISOs\Windows_10_RS3.iso	SUCCESS	Offset: 10,485,760. Length: 1,048,576. I/O Flags: Non-cached, Paging I/O, Synchron...
System	4	WriteFile	C:\ISOs\Windows_10_RS3.iso	SUCCESS	Offset: 11,534,336. Length: 1,048,576. I/O Flags: Non-cached, Paging I/O, Synchron...
System	4	WriteFile	C:\ISOs\Windows_10_RS3.iso	SUCCESS	Offset: 12,582,912. Length: 1,048,576. I/O Flags: Non-cached, Paging I/O, Synchron...
System	4	WriteFile	C:\ISOs\Windows_10_RS3.iso	SUCCESS	Offset: 13,631,488. Length: 1,048,576. I/O Flags: Non-cached, Paging I/O, Synchron...

Showing 1,513 of 375,612 events (0.40%) Backed by virtual memory

The write operation's stack trace, shown here, indicates that the memory manager's *mapped page writer* thread was actually responsible for the write. This occurs because for the first couple of megabytes of data, the cache manager hadn't started performing write-behind, so the memory manager's mapped page writer began flushing the modified destination file data. (See Chapter 10 for more information on the mapped page writer.)

To get a clearer view of the cache manager operations, remove Explorer from the Process Monitor's filter so that only the System process operations are visible, as shown next.

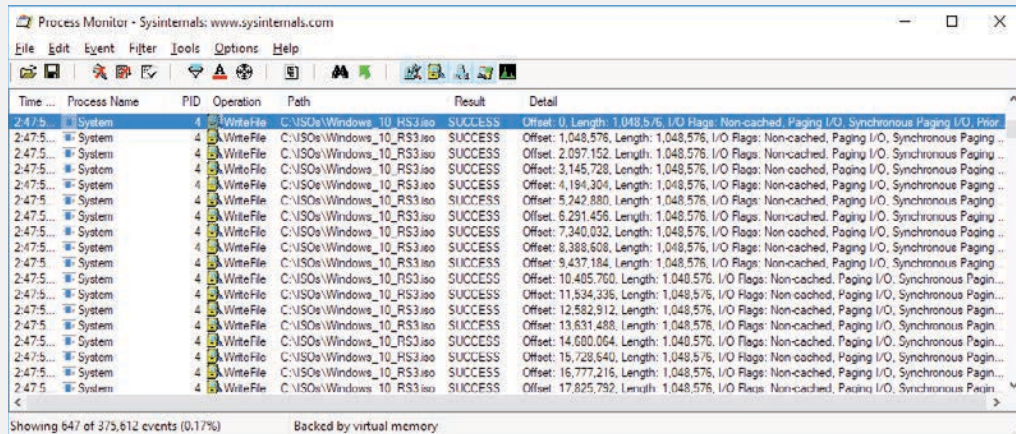

With this view, it's much easier to see the cache manager's 1-MB write-behind operations (the maximum write sizes are 1 MB on client versions of Windows and 32 MB on server versions; this experiment was performed on a client system). The stack trace for one of the write-behind operations, shown here, verifies that a cache manager worker thread is performing write-behind:

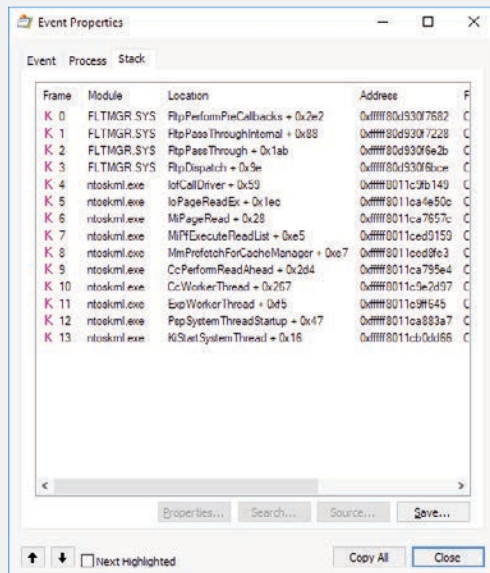

As an added experiment, try repeating this process with a remote copy instead (from one Windows system to another) and by copying files of varying sizes. You'll notice some different behaviors by the copy engine and the cache manager, both on the receiving and sending sides.

Disabling lazy writing for a file

If you create a temporary file by specifying the flag `FILE_ATTRIBUTE_TEMPORARY` in a call to the Windows `CreateFile` function, the lazy writer won't write dirty pages to the disk unless there is a severe shortage of physical memory or the file is explicitly flushed. This characteristic of the lazy writer improves system performance—the lazy writer doesn't immediately write data to a disk that might ultimately be discarded. Applications usually delete temporary files soon after closing them.

Forcing the cache to write through to disk

Because some applications can't tolerate even momentary delays between writing a file and seeing the updates on disk, the cache manager also supports write-through caching on a per-file object basis; changes are written to disk as soon as they're made. To turn on write-through caching, set the `FILE_FLAG_WRITE_THROUGH` flag in the call to the `CreateFile` function. Alternatively, a thread can explicitly flush an open file by using the Windows `FlushFileBuffers` function when it reaches a point at which the data needs to be written to disk.

Flushing mapped files

If the lazy writer must write data to disk from a view that's also mapped into another process's address space, the situation becomes a little more complicated because the cache manager will only know about the pages it has modified. (Pages modified by another process are known only to that process because the modified bit in the page table entries for modified pages is kept in the process private page tables.) To address this situation, the memory manager informs the cache manager when a user maps a file. When such a file is flushed in the cache (for example, as a result of a call to the Windows `FlushFileBuffers` function), the cache manager writes the dirty pages in the cache and then checks to see whether the file is also mapped by another process. When the cache manager sees that the file is also mapped by another process, the cache manager then flushes the entire view of the section to write out pages that the second process might have modified. If a user maps a view of a file that is also open in the cache, when the view is unmapped, the modified pages are marked as dirty so that when the lazy writer thread later flushes the view, those dirty pages will be written to disk. This procedure works as long as the sequence occurs in the following order:

1. A user unmaps the view.
2. A process flushes file buffers.

If this sequence isn't followed, you can't predict which pages will be written to disk.

EXPERIMENT: Watching cache flushes

You can see the cache manager map views into the system cache and flush pages to disk by running the Performance Monitor and adding the Data Maps/sec and Lazy Write Flushes/sec counters. (You can find these counters under the “Cache” group.) Then, copy a large file from one location to another. The generally higher line in the following screenshot shows Data Maps/sec, and the other shows Lazy Write Flushes/sec. During the file copy, Lazy Write Flushes/sec significantly increased.

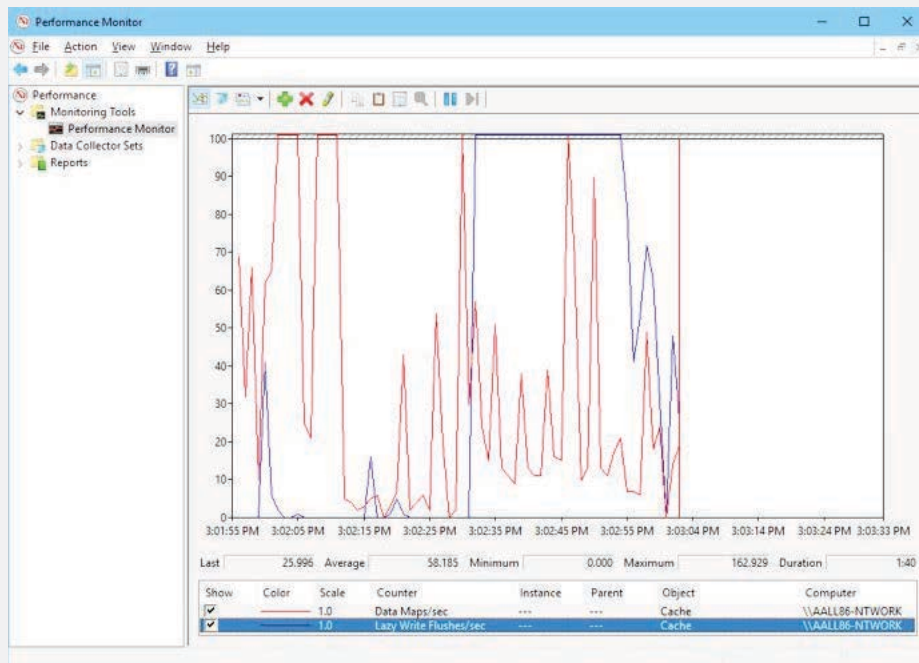

Write throttling

The file system and cache manager must determine whether a cached write request will affect system performance and then schedule any delayed writes. First, the file system asks the cache manager whether a certain number of bytes can be written right now without hurting performance by using the *CcCanIWrite* function and blocking that write if necessary. For asynchronous I/O, the file system sets up a callback with the cache manager for automatically writing the bytes when writes are again permitted by calling *CcDeferWrite*. Otherwise, it just blocks and waits on *CcCanIWrite* to continue. Once it's notified of an impending write operation, the cache manager determines how many dirty pages are in the cache and how much physical memory is available. If few physical pages are free, the cache manager momentarily blocks the file system thread that's requesting to write data to the cache. The cache manager's lazy writer flushes some of the dirty pages to disk and then allows the blocked file system thread to continue. This *write throttling* prevents system performance from degrading because of a lack of memory when a file system or network server issues a large write operation.



Note The effects of write throttling are volume-aware, such that if a user is copying a large file on, say, a RAID-0 SSD while also transferring a document to a portable USB thumb drive, writes to the USB disk will not cause write throttling to occur on the SSD transfer.

The *dirty page threshold* is the number of pages that the system cache will allow to be dirty before throttling cached writers. This value is computed when the cache manager partition is initialized (the system partition is created and initialized at phase 1 of the NT kernel startup) and depends on the product type (client or server). As seen in the previous paragraphs, two other values are also computed—the *top* dirty page threshold and the *bottom* dirty page threshold. Depending on memory consumption and the rate at which dirty pages are being processed, the lazy writer scan calls the internal function *CcAdjustThrottle*, which, on server systems, performs dynamic adjustment of the current threshold based on the calculated top and bottom values. This adjustment is made to preserve the read cache in cases of a heavy write load that will inevitably overrun the cache and become throttled. Table 11-1 lists the algorithms used to calculate the dirty page thresholds.

TABLE 11-1 Algorithms for calculating the dirty page thresholds

Product Type	Dirty Page Threshold	Top Dirty Page Threshold	Bottom Dirty Page Threshold
Client	Physical pages / 8	Physical pages / 8	Physical pages / 8
Server	Physical pages / 2	Physical pages / 2	Physical pages / 8

Write throttling is also useful for network redirectors transmitting data over slow communication lines. For example, suppose a local process writes a large amount of data to a remote file system over a slow 640 Kbps line. The data isn't written to the remote disk until the cache manager's lazy writer flushes the cache. If the redirector has accumulated lots of dirty pages that are flushed to disk at once, the recipient could receive a network timeout before the data transfer completes. By using the *CcSetDirtyPageThreshold* function, the cache manager allows network redirectors to set a limit on the number of dirty cache pages they can tolerate (for each stream), thus preventing this scenario. By limiting the number of dirty pages, the redirector ensures that a cache flush operation won't cause a network timeout.

System threads

As mentioned earlier, the cache manager performs lazy write and read-ahead I/O operations by submitting requests to the common critical system worker thread pool. However, it does limit the use of these threads to one less than the total number of critical system worker threads. In client systems, there are 5 total critical system worker threads, whereas in server systems there are 10.

Internally, the cache manager organizes its work requests into four lists (though these are serviced by the same set of executive worker threads):

- The express queue is used for read-ahead operations.
- The regular queue is used for lazy write scans (for dirty data to flush), write-behinds, and lazy closes.

- The fast teardown queue is used when the memory manager is waiting for the data section owned by the cache manager to be freed so that the file can be opened with an image section instead, which causes *CcWriteBehind* to flush the entire file and tear down the shared cache map.
- The post tick queue is used for the cache manager to internally register for a notification after each “tick” of the lazy writer thread—in other words, at the end of each pass.

To keep track of the work items the worker threads need to perform, the cache manager creates its own internal *per-processor look-aside list*—a fixed-length list (one for each processor) of worker queue item structures. (Look-aside lists are discussed in Chapter 5 of Part 1.) The number of worker queue items depends on system type: 128 for client systems, and 256 for server systems. For cross-processor performance, the cache manager also allocates a *global look-aside list* at the same sizes as just described.

Aggressive write behind and low-priority lazy writes

With the goal of improving cache manager performance, and to achieve compatibility with low-speed disk devices (like eMMC disks), the cache manager lazy writer has gone through substantial improvements in Windows 8.1 and later.

As seen in the previous paragraphs, the lazy writer scan adjusts the dirty page threshold and its top and bottom limits. Multiple adjustments are made on the limits, by analyzing the history of the total number of available pages. Other adjustments are performed to the dirty page threshold itself by checking whether the lazy writer has been able to write the expected total number of pages in the last execution cycle (one per second). If the total number of written pages in the last cycle is less than the expected number (calculated by the *CcCalculatePagesToWrite* routine), it means that the underlying disk device was not able to support the generated I/O throughput, so the dirty page threshold is lowered (this means that more I/O throttling is performed, and some cache manager clients will wait when calling *CcCanIWrite* API). In the opposite case, in which there are no remaining pages from the last cycle, the lazy writer scan can easily raise the threshold. In both cases, the threshold needs to stay inside the range described by the bottom and top limits.

The biggest improvement has been made thanks to the *Extra Write Behind* worker threads. In server SKUs, the maximum number of these threads is nine (which corresponds to the total number of critical system worker threads minus one), while in client editions it is only one. When a system lazy write scan is requested by the cache manager, the system checks whether dirty pages are contributing to memory pressure (using a simple formula that verifies that the number of dirty pages are less than a quarter of the dirty page threshold, and less than half of the available pages). If so, the systemwide cache manager thread pool routine (*CcWorkerThread*) uses a complex algorithm that determines whether it can add another lazy writer thread that will write dirty pages to disk in parallel with the others.

To correctly understand whether it is possible to add another thread that will emit additional I/Os, without getting worse system performance, the cache manager calculates the disk throughput of the old lazy write cycles and keeps track of their performance. If the throughput of the current cycles is equal or better than the previous one, it means that the disk can support the overall I/O level, so it makes sense to add another lazy writer thread (which is called an *Extra Write Behind* thread in this

case). If, on the other hand, the current throughput is lower than the previous cycle, it means that the underlying disk is not able to sustain additional parallel writes, so the Extra Write Behind thread is removed. This feature is called *Aggressive Write Behind*.

In Windows client editions, the cache manager enables an optimization designed to deal with low-speed disks. When a lazy writer scan is requested, and when the file system drivers write to the cache, the cache manager employs an algorithm to decide if the lazy writers threads should execute at low priority. (For more information about thread priorities, refer to Chapter 4 of Part 1.) The cache manager applies by-default low priority to the lazy writers if the following conditions are met (otherwise, the cache manager still uses the normal priority):

- The caller is not waiting for the current lazy scan to be finished.
- The total size of the partition's dirty pages is less than 32 MB.

If the two conditions are satisfied, the cache manager queues the work items for the lazy writers in the low-priority queue. The lazy writers are started by a system worker thread, which executes at priority 6 – Lowest. Furthermore, the lazy writer set its I/O priority to Lowest just before emitting the actual I/O to the correct file-system driver.

Dynamic memory

As seen in the previous paragraph, the dirty page threshold is calculated dynamically based on the available amount of physical memory. The cache manager uses the threshold to decide when to throttle incoming writes and whether to be more aggressive about writing behind.

Before the introduction of partitions, the calculation was made in the *CcInitializeCacheManager* routine (by checking the *MmNumberOfPhysicalPages* global value), which was executed during the kernel's phase 1 initialization. Now, the cache manager Partition's initialization function performs the calculation based on the available physical memory pages that belong to the associated memory partition. (For further details about cache manager partitions, see the section "Memory partitions support," earlier in this chapter.) This is not enough, though, because Windows also supports the hot-addition of physical memory, a feature that is deeply used by HyperV for supporting dynamic memory for child VMs.

During memory manager phase 0 initialization, *MiCreatePfnDatabase* calculates the maximum possible size of the PFN database. On 64-bit systems, the memory manager assumes that the maximum possible amount of installed physical memory is equal to all the addressable virtual memory range (256 TB on non-LA57 systems, for example). The system asks the memory manager to reserve the amount of virtual address space needed to store a PFN for each virtual page in the entire address space. (The size of this hypothetical PFN database is around 64 GB.) *MiCreateSparsePfnDatabase* then cycles between each valid physical memory range that Winload has detected and maps valid PFNs into the database. The PFN database uses sparse memory. When the *MiAddPhysicalMemory* routines detect new physical memory, it creates new PFNs simply by allocating new regions inside the PFN databases. Dynamic Memory has already been described in Chapter 9, "Virtualization technologies"; further details are available there.

The cache manager needs to detect the new hot-added or hot-removed memory and adapt to the new system configuration, otherwise multiple problems could arise:

- In cases where new memory has been hot-added, the cache manager might think that the system has less memory, so its dirty pages threshold is lower than it should be. As a result, the cache manager doesn't cache as many dirty pages as it should, so it throttles writes much sooner.
- If large portions of available memory are locked or aren't available anymore, performing cached I/O on the system could hurt the responsiveness of other applications (which, after the hot-remove, will basically have no more memory).

To correctly deal with this situation, the cache manager doesn't register a callback with the memory manager but implements an adaptive correction in the lazy writer scan (LWS) thread. Other than scanning the list of shared cache map and deciding which dirty page to write, the LWS thread has the ability to change the dirty pages threshold depending on foreground rate, its write rate, and available memory. The LWS maintains a history of average available physical pages and dirty pages that belong to the partition. Every second, the LWS thread updates these lists and calculates aggregate values. Using the aggregate values, the LWS is able to respond to memory size variations, absorbing the spikes and gradually modifying the top and bottom thresholds.

Cache manager disk I/O accounting

Before Windows 8.1, it wasn't possible to precisely determine the total amount of I/O performed by a single process. The reasons behind this were multiple:

- Lazy writes and read-aheads don't happen in the context of the process/thread that caused the I/O. The cache manager writes out the data lazily, completing the write in a different context (usually the System context) of the thread that originally wrote the file. (The actual I/O can even happen after the process has terminated.) Likewise, the cache manager can choose to read-ahead, bringing in more data from the file than the process requested.
- Asynchronous I/O is still managed by the cache manager, but there are cases in which the cache manager is not involved at all, like for non-cached I/Os.
- Some specialized applications can emit low-level disk I/O using a lower-level driver in the disk stack.

Windows stores a pointer to the thread that emitted the I/O in the tail of the IRP. This thread is not always the one that originally started the I/O request. As a result, a lot of times the I/O accounting was wrongly associated with the System process. Windows 8.1 resolved the problem by introducing the *PsUpdateDiskCounters* API, used by both the cache manager and file system drivers, which need to tightly cooperate. The function stores the total number of bytes read and written and the number of I/O operations in the core *EPROCESS* data structure that is used by the NT kernel to describe a process. (You can read more details in Chapter 3 of Part 1.)

The cache manager updates the process disk counters (by calling the *PsUpdateDiskCounters* function) while performing cached reads and writes (through all of its exposed file system interfaces) and while emitting read-aheads I/O (through *CcScheduleReadAheadEx* exported API). NTFS and ReFS file systems drivers call the *PsUpdateDiskCounters* while performing non-cached and paging I/O.

Like *CcScheduleReadAheadEx*, multiple cache manager APIs have been extended to accept a pointer to the thread that has emitted the I/O and should be charged for it (*CcCopyReadEx* and *CcCopyWriteEx* are good examples). In this way, updated file system drivers can even control which thread to charge in case of asynchronous I/O.

Other than per-process counters, the cache manager also maintains a Global Disk I/O counter, which globally keeps track of all the I/O that has been issued by file systems to the storage stack. (The counter is updated every time a non-cached and paging I/O is emitted through file system drivers.) Thus, this global counter, when subtracted from the total I/O emitted to a particular disk device (a value that an application can obtain by using the *IOCTL_DISK_PERFORMANCE* control code), represents the I/O that could not be attributed to any particular process (paging I/O emitted by the Modified Page Writer for example, or I/O performed internally by Mini-filter drivers).

The new per-process disk counters are exposed through the *NtQuerySystemInformation* API using the *SystemProcessInformation* information class. This is the method that diagnostics tools like Task Manager or Process Explorer use for precisely querying the I/O numbers related to the processes currently running in the system.

EXPERIMENT: Counting disk I/Os

You can see a precise counting of the total system I/Os by using the different counters exposed by the Performance Monitor. Open Performance Monitor and add the *FileSystem Bytes Read* and *FileSystem Bytes Written* counters, which are available in the *FileSystem Disk Activity* group. Furthermore, for this experiment you need to add the per-process disk I/O counters that are available in the *Process* group, named *IO Read Bytes/sec* and *IO Write Bytes/sec*. When you add these last two counters, make sure that you select the *Explorer* process in the *Instances Of Selected Object* box.

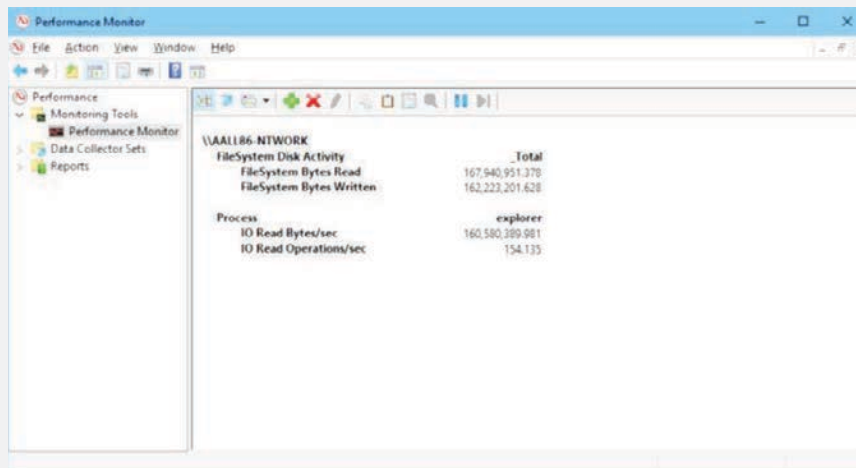

When you start to copy a big file, you see the counters belonging to Explorer processes increasing until they reach the counters showed in the global file System Disk activity.

File systems

In this section, we present an overview of the supported file system formats supported by Windows. We then describe the types of file system drivers and their basic operation, including how they interact with other system components, such as the memory manager and the cache manager. Following that, we describe in detail the functionality and the data structures of the two most important file systems: NTFS and ReFS. We start by analyzing their internal architectures and then focus on the on-disk layout of the two file systems and their advanced features, such as compression, recoverability, encryption, tiering support, file-snapshot, and so on.

Windows file system formats

Windows includes support for the following file system formats:

- CDFS
- UDF
- FAT12, FAT16, and FAT32
- exFAT
- NTFS
- ReFS

Each of these formats is best suited for certain environments, as you'll see in the following sections.

CDFS

CDFS (`%SystemRoot%\System32\Drivers\Cdfs.sys`), or CD-ROM file system, is a read-only file system driver that supports a superset of the ISO-9660 format as well as a superset of the Joliet disk format. Although the ISO-9660 format is relatively simple and has limitations such as ASCII uppercase names with a maximum length of 32 characters, Joliet is more flexible and supports Unicode names of arbitrary length. If structures for both formats are present on a disk (to offer maximum compatibility), CDFS uses the Joliet format. CDFS has a couple of restrictions:

- A maximum file size of 4 GB
- A maximum of 65,535 directories

CDFS is considered a legacy format because the industry has adopted the Universal Disk Format (UDF) as the standard for optical media.

UDF

The Windows Universal Disk Format (UDF) file system implementation is OSTA (Optical Storage Technology Association) UDF-compliant. (UDF is a subset of the ISO-13346 format with extensions for formats such as CD-R and DVD-R/RW.) OSTA defined UDF in 1995 as a format to replace the ISO-9660 format for magneto-optical storage media, mainly DVD-ROM. UDF is included in the DVD specification and is more flexible than CDFS. The UDF file system format has the following traits:

- Directory and file names can be 254 ASCII or 127 Unicode characters long.
- Files can be sparse. (Sparse files are defined later in this chapter, in the “Compression and sparse files” section.)
- File sizes are specified with 64 bits.
- Support for access control lists (ACLs).
- Support for alternate data streams.

The UDF driver supports UDF versions up to 2.60. The UDF format was designed with rewritable media in mind. The Windows UDF driver (%SystemRoot%\System32\Drivers\Udfs.sys) provides read-write support for Blu-ray, DVD-RAM, CD-R/RW, and DVD+-R/RW drives when using UDF 2.50 and read-only support when using UDF 2.60. However, Windows does not implement support for certain UDF features such as named streams and access control lists.

FAT12, FAT16, and FAT32

Windows supports the FAT file system primarily for compatibility with other operating systems in multiboot systems, and as a format for flash drives or memory cards. The Windows FAT file system driver is implemented in %SystemRoot%\System32\Drivers\Fastfat.sys.

The name of each FAT format includes a number that indicates the number of bits that the particular format uses to identify clusters on a disk. FAT12’s 12-bit cluster identifier limits a partition to storing a maximum of 2^{12} (4,096) clusters. Windows permits cluster sizes from 512 bytes to 8 KB, which limits a FAT12 volume size to 32 MB.



Note All FAT file system types reserve the first 2 clusters and the last 16 clusters of a volume, so the number of usable clusters for a FAT12 volume, for instance, is slightly less than 4,096.

FAT16, with a 16-bit cluster identifier, can address 2^{16} (65,536) clusters. On Windows, FAT16 cluster sizes range from 512 bytes (the sector size) to 64 KB (on disks with a 512-byte sector size), which limits FAT16 volume sizes to 4 GB. Disks with a sector size of 4,096 bytes allow for clusters of 256 KB. The cluster size Windows uses depends on the size of a volume. The various sizes are listed in Table 11-2. If you format a volume that is less than 16 MB as FAT by using the *format* command or the Disk Management snap-in, Windows uses the FAT12 format instead of FAT16.

TABLE 11-2 Default FAT16 cluster sizes in Windows

Volume Size	Default Cluster Size
<8 MB	Not supported
8 MB–32 MB	512 bytes
32 MB–64 MB	1 KB
64 MB–128 MB	2 KB
128 MB–256 MB	4 KB
256 MB–512 MB	8 KB
512 MB–1,024 MB	16 KB
1 GB–2 GB	32 KB
2 GB–4 GB	64 KB
>16 GB	Not supported

A FAT volume is divided into several regions, which are shown in Figure 11-14. The file allocation table, which gives the FAT file system format its name, has one entry for each cluster on a volume. Because the file allocation table is critical to the successful interpretation of a volume’s contents, the FAT format maintains two copies of the table so that if a file system driver or consistency-checking program (such as Chkdsk) can’t access one (because of a bad disk sector, for example), it can read from the other.

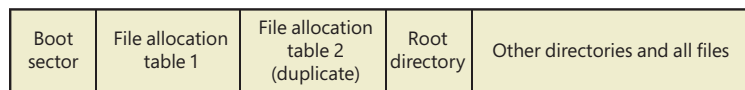

FIGURE 11-14 FAT format organization.

Entries in the file allocation table define file-allocation chains (shown in Figure 11-15) for files and directories, where the links in the chain are indexes to the next cluster of a file’s data. A file’s directory entry stores the starting cluster of the file. The last entry of the file’s allocation chain is the reserved value of 0xFFFF for FAT16 and 0xFFF for FAT12. The FAT entries for unused clusters have a value of 0. You can see in Figure 11-15 that FILE1 is assigned clusters 2, 3, and 4; FILE2 is fragmented and uses clusters 5, 6, and 8; and FILE3 uses only cluster 7. Reading a file from a FAT volume can involve reading large portions of a file allocation table to traverse the file’s allocation chains.

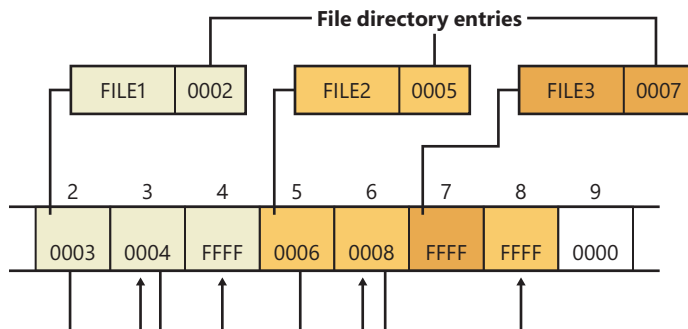

FIGURE 11-15 Sample FAT file-allocation chains.

The root directory of FAT12 and FAT16 volumes is preassigned enough space at the start of a volume to store 256 directory entries, which places an upper limit on the number of files and directories that can be stored in the root directory. (There's no preassigned space or size limit on FAT32 root directories.) A FAT directory entry is 32 bytes and stores a file's name, size, starting cluster, and time stamp (last-accessed, created, and so on) information. If a file has a name that is Unicode or that doesn't follow the MS-DOS 8.3 naming convention, additional directory entries are allocated to store the long file name. The supplementary entries precede the file's main entry. Figure 11-16 shows a sample directory entry for a file named "The quick brown fox." The system has created a THEQUI~1.FOX 8.3 representation of the name (that is, you don't see a "." in the directory entry because it is assumed to come after the eighth character) and used two more directory entries to store the Unicode long file name. Each row in the figure is made up of 16 bytes.

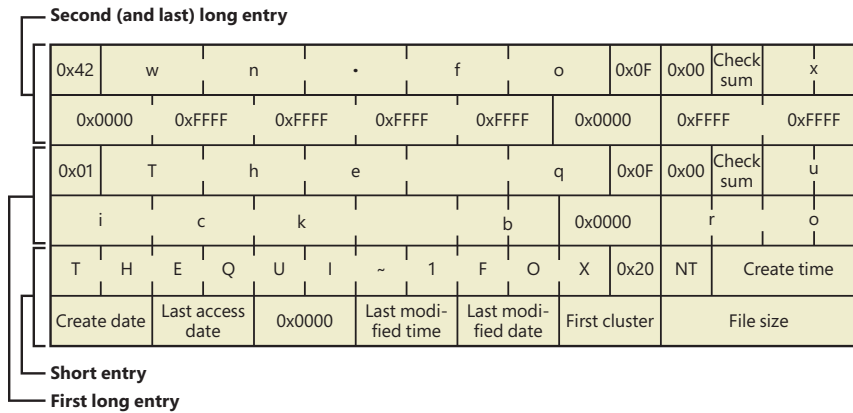

FIGURE 11.16 FAT directory entry.

FAT32 uses 32-bit cluster identifiers but reserves the high 4 bits, so in effect it has 28-bit cluster identifiers. Because FAT32 cluster sizes can be as large as 64 KB, FAT32 has a theoretical ability to address 16-terabyte (TB) volumes. Although Windows works with existing FAT32 volumes of larger sizes (created in other operating systems), it limits new FAT32 volumes to a maximum of 32 GB. FAT32's higher potential cluster numbers let it manage disks more efficiently than FAT16; it can handle up to 128-GB volumes with 512-byte clusters. Table 11-3 shows default cluster sizes for FAT32 volumes.

TABLE 11-3 Default cluster sizes for FAT32 volumes

Partition Size	Default Cluster Size
<32 MB	Not supported
32 MB–64 MB	512 bytes
64 MB–128 MB	1 KB
128 MB–256 MB	2 KB
256 MB–8 GB	4 KB
8 GB–16 GB	8 KB
16 GB–32 GB	16 KB
>32 GB	Not supported

Besides the higher limit on cluster numbers, other advantages FAT32 has over FAT12 and FAT16 include the fact that the FAT32 root directory isn't stored at a predefined location on the volume, the root directory doesn't have an upper limit on its size, and FAT32 stores a second copy of the boot sector for reliability. A limitation FAT32 shares with FAT16 is that the maximum file size is 4 GB because directories store file sizes as 32-bit values.

exFAT

Designed by Microsoft, the Extended File Allocation Table file system (exFAT, also called FAT64) is an improvement over the traditional FAT file systems and is specifically designed for flash drives. The main goal of exFAT is to provide some of the advanced functionality offered by NTFS without the metadata structure overhead and metadata logging that create write patterns not suited for many flash media devices. Table 11-4 lists the default cluster sizes for exFAT.

As the FAT64 name implies, the file size limit is increased to 2^{64} , allowing files up to 16 exabytes. This change is also matched by an increase in the maximum cluster size, which is currently implemented as 32 MB but can be as large as 2^{255} sectors. exFAT also adds a bitmap that tracks free clusters, which improves the performance of allocation and deletion operations. Finally, exFAT allows more than 1,000 files in a single directory. These characteristics result in increased scalability and support for large disk sizes.

TABLE 11-4 Default cluster sizes for exFAT volumes, 512-byte sector

Volume Size	Default Cluster Size
< 256 MB	4 KB
256 MB–32 GB	32 KB
32 GB–512 GB	128 KB
512 GB–1 TB	256 KB
1 TB–2 TB	512 KB
2 TB–4 TB	1 MB
4 TB–8 TB	2 MB
8 TB–16 TB	4 MB
16 TB–32 TB	8 MB
32 TB–64 TB	16 MB
≥ 64 TB	32 MB

Additionally, exFAT implements certain features previously available only in NTFS, such as support for access control lists (ACLs) and transactions (called Transaction-Safe FAT, or TFAT). While the Windows Embedded CE implementation of exFAT includes these features, the version of exFAT in Windows does not.



Note ReadyBoost (described in Chapter 5 of Part 1, “Memory Management”) can work with exFAT-formatted flash drives to support cache files much larger than 4 GB.

NTFS

As noted at the beginning of the chapter, the NTFS file system is one of the native file system formats of Windows. NTFS uses 64-bit cluster numbers. This capacity gives NTFS the ability to address volumes of up to 16 exaclusters; however, Windows limits the size of an NTFS volume to that addressable with 32-bit clusters, which is slightly less than 8 petabytes (using 2 MB clusters). Table 11-5 shows the default cluster sizes for NTFS volumes. (You can override the default when you format an NTFS volume.) NTFS also supports $2^{32}-1$ files per volume. The NTFS format allows for files that are 16 exabytes in size, but the implementation limits the maximum file size to 16 TB.

TABLE 11-5 Default cluster sizes for NTFS volumes

Volume Size	Default Cluster Size
<7 MB	Not supported
7 MB–16 TB	4 KB
16 TB–32 TB	8 KB
32 TB–64 TB	16 KB
64 TB–128 TB	32 KB
128 TB–256 TB	64 KB
256 TB–512 TB	128 KB
512 TB–1024 TB	256 KB
1 PB–2 PB	512 KB
2 PB–4 PB	1 MB
4 PB–8 PB	2 MB

NTFS includes a number of advanced features, such as file and directory security, alternate data streams, disk quotas, sparse files, file compression, symbolic (soft) and hard links, support for transactional semantics, junction points, and encryption. One of its most significant features is *recoverability*. If a system is halted unexpectedly, the metadata of a FAT volume can be left in an inconsistent state, leading to the corruption of large amounts of file and directory data. NTFS logs changes to metadata in a transactional manner so that file system structures can be repaired to a consistent state with no loss of file or directory structure information. (File data can be lost unless the user is using TxF, which is covered later in this chapter.) Additionally, the NTFS driver in Windows also implements *self-healing*, a mechanism through which it makes most minor repairs to corruption of file system on-disk structures while Windows is running and without requiring a reboot.



Note At the time of this writing, the common physical sector size of disk devices is 4 KB. Even for these disk devices, for compatibility reasons, the storage stack exposes to file system drivers a logical sector size of 512 bytes. The calculation performed by the NTFS driver to determine the correct size of the cluster uses logical sector sizes rather than the actual physical size.

Starting with Windows 10, NTFS supports DAX volumes natively. (DAX volumes are discussed later in this chapter, in the “DAX volumes” section.) The NTFS file system driver also supports I/O to this kind of volume using large pages. Mapping a file that resides on a DAX volume using large pages is possible in two ways: NTFS can automatically align the file to a 2-MB cluster boundary, or the volume can be formatted using a 2-MB cluster size.

ReFS

The Resilient File System (ReFS) is another file system that Windows supports natively. It has been designed primarily for large storage servers with the goal to overcome some limitations of NTFS, like its lack of online self-healing or volume repair or the nonsupport for file snapshots. ReFS is a “write-to-new” file system, which means that volume metadata is always updated by writing new data to the underlying medium and by marking the old metadata as deleted. The lower level of the ReFS file system (which understands the on-disk data structure) uses an object store library, called Minstore, that provides a key-value table interface to its callers. Minstore is similar to a modern database engine, is portable, and uses different data structures and algorithms compared to NTFS. (Minstore uses B+ trees.)

One of the important design goals of ReFS was to be able to support huge volumes (that could have been created by Storage Spaces). Like NTFS, ReFS uses 64-bit cluster numbers and can address volumes of up to 16 exaclusters. ReFS has no limitation on the size of the addressable values, so, theoretically, ReFS is able to manage volumes of up to 1 yottabyte (using 64 KB cluster sizes).

Unlike NTFS, Minstore doesn’t need a central location to store its own metadata on the volume (although the object table could be considered somewhat centralized) and has no limitations on addressable values, so there is no need to support many different sized clusters. ReFS supports only 4 KB and 64 KB cluster sizes. ReFS, at the time of this writing, does not support DAX volumes.

We describe NTFS and ReFS data structures and their advanced features in detail later in this chapter.

File system driver architecture

File system drivers (FSDs) manage file system formats. Although FSDs run in kernel mode, they differ in a number of ways from standard kernel-mode drivers. Perhaps most significant, they must register as an FSD with the I/O manager, and they interact more extensively with the memory manager. For enhanced performance, file system drivers also usually rely on the services of the cache manager. Thus, they use a superset of the exported Ntoskrnl.exe functions that standard drivers use. Just as for standard kernel-mode drivers, you must have the Windows Driver Kit (WDK) to build file system drivers. (See Chapter 1, “Concepts and Tools,” in Part 1 and <http://www.microsoft.com/whdc/devtools/wdk> for more information on the WDK.)

Windows has two different types of FSDs:

- *Local FSDs* manage volumes directly connected to the computer.
- *Network FSDs* allow users to access data volumes connected to remote computers.

Local FSDs

Local FSDs include Ntfs.sys, Refs.sys, Refsv1.sys, Fastfat.sys, Exfat.sys, Udfs.sys, Cdfs.sys, and the RAW FSD (integrated in Ntoskrnl.exe). Figure 11-17 shows a simplified view of how local FSDs interact with the I/O manager and storage device drivers. A local FSD is responsible for registering with the I/O manager. Once the FSD is registered, the I/O manager can call on it to perform volume recognition when applications or the system initially access the volumes. Volume recognition involves an examination of a volume's boot sector and often, as a consistency check, the file system metadata. If none of the registered file systems recognizes the volume, the system assigns the RAW file system driver to the volume and then displays a dialog box to the user asking if the volume should be formatted. If the user chooses not to format the volume, the RAW file system driver provides access to the volume, but only at the sector level—in other words, the user can only read or write complete sectors.

The goal of file system recognition is to allow the system to have an additional option for a valid but unrecognized file system other than RAW. To achieve this, the system defines a fixed data structure type (`FILE_SYSTEM_RECOGNITION_STRUCTURE`) that is written to the first sector on the volume. This data structure, if present, would be recognized by the operating system, which would then notify the user that the volume contains a valid but unrecognized file system. The system will still load the RAW file system on the volume, but it will not prompt the user to format the volume. A user application or kernel-mode driver might ask for a copy of the `FILE_SYSTEM_RECOGNITION_STRUCTURE` by using the new file system I/O control code `FSCTL_QUERY_FILE_SYSTEM_RECOGNITION`.

The first sector of every Windows-supported file system format is reserved as the volume's boot sector. A boot sector contains enough information so that a local FSD can both identify the volume on which the sector resides as containing a format that the FSD manages and locate any other metadata necessary to identify where metadata is stored on the volume.

When a local FSD (shown in Figure 11-17) recognizes a volume, it creates a device object that represents the mounted file system format. The I/O manager makes a connection through the *volume parameter block* (VPB) between the volume's device object (which is created by a storage device driver) and the device object that the FSD created. The VPB's connection results in the I/O manager redirecting I/O requests targeted at the volume device object to the FSD device object.

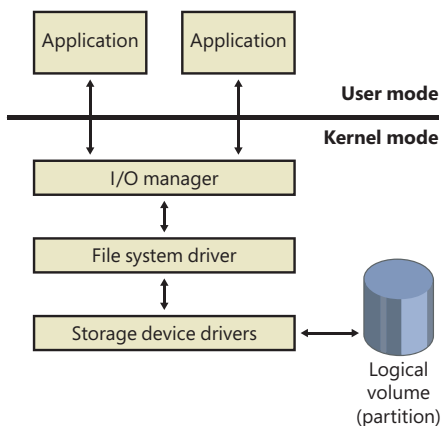

FIGURE 11-17 Local FSD.

To improve performance, local FSDs usually use the cache manager to cache file system data, including metadata. FSDs also integrate with the memory manager so that mapped files are implemented correctly. For example, FSDs must query the memory manager whenever an application attempts to truncate a file to verify that no processes have mapped the part of the file beyond the truncation point. (See Chapter 5 of Part 1 for more information on the memory manager.) Windows doesn't permit file data that is mapped by an application to be deleted either through truncation or file deletion.

Local FSDs also support file system dismount operations, which permit the system to disconnect the FSD from the volume object. A dismount occurs whenever an application requires raw access to the on-disk contents of a volume or the media associated with a volume is changed. The first time an application accesses the media after a dismount, the I/O manager reinitiates a volume mount operation for the media.

Remote FSDs

Each remote FSD consists of two components: a client and a server. A client-side remote FSD allows applications to access remote files and directories. The client FSD component accepts I/O requests from applications and translates them into network file system protocol commands (such as SMB) that the FSD sends across the network to a server-side component, which is a remote FSD. A server-side FSD listens for commands coming from a network connection and fulfills them by issuing I/O requests to the local FSD that manages the volume on which the file or directory that the command is intended for resides.

Windows includes a client-side remote FSD named LANMan Redirector (usually referred to as just the *redirector*) and a server-side remote FSD named LANMan Server (%SystemRoot%\System32\Drivers\Srv2.sys). Figure 11-18 shows the relationship between a client accessing files remotely from a server through the redirector and server FSDs.

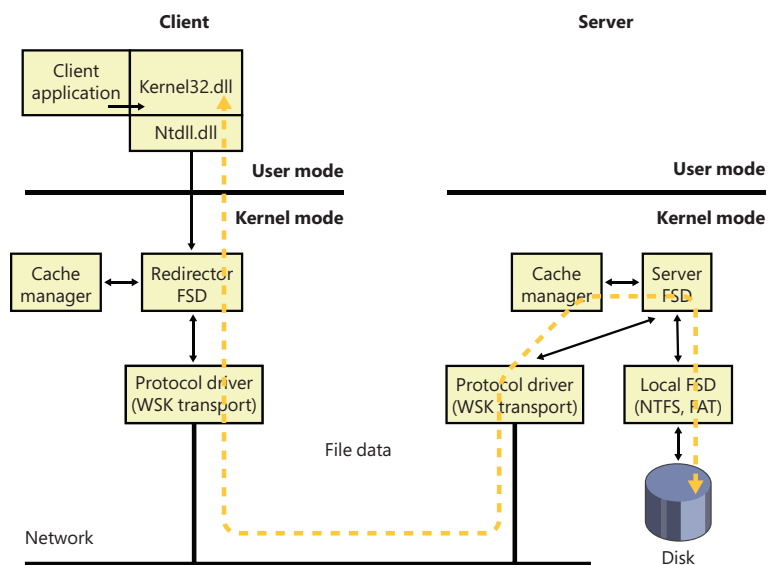

FIGURE 11-18 Common Internet File System file sharing.

Windows relies on the Common Internet File System (CIFS) protocol to format messages exchanged between the redirector and the server. CIFS is a version of Microsoft's Server Message Block (SMB) protocol. (For more information on SMB, go to <https://docs.microsoft.com/en-us/windows/win32/fileio/microsoft-smb-protocol-and-cifs-protocol-overview>.)

Like local FSDs, client-side remote FSDs usually use cache manager services to locally cache file data belonging to remote files and directories, and in such cases both must implement a distributed locking mechanism on the client as well as the server. SMB client-side remote FSDs implement a distributed cache coherency protocol, called *oplock* (opportunistic locking), so that the data an application sees when it accesses a remote file is the same as the data applications running on other computers that are accessing the same file see. Third-party file systems may choose to use the oplock protocol, or they may implement their own protocol. Although server-side remote FSDs participate in maintaining cache coherency across their clients, they don't cache data from the local FSDs because local FSDs cache their own data.

It is fundamental that whenever a resource can be shared between multiple, simultaneous accessors, a serialization mechanism must be provided to arbitrate writes to that resource to ensure that only one accessor is writing to the resource at any given time. Without this mechanism, the resource may be corrupted. The locking mechanisms used by all file servers implementing the SMB protocol are the oplock and the lease. Which mechanism is used depends on the capabilities of both the server and the client, with the lease being the preferred mechanism.

Oplocks The oplock functionality is implemented in the file system run-time library (*FsRtlXxx* functions) and may be used by any file system driver. The client of a remote file server uses an oplock to dynamically determine which client-side caching strategy to use to minimize network traffic. An oplock is requested on a file residing on a share, by the file system driver or redirector, on behalf of an application when it attempts to open a file. The granting of an oplock allows the client to cache the file rather than send every read or write to the file server across the network. For example, a client could open a file for exclusive access, allowing the client to cache all reads and writes to the file, and then copy the updates to the file server when the file is closed. In contrast, if the server does not grant an oplock to a client, all reads and writes must be sent to the server.

Once an oplock has been granted, a client may then start caching the file, with the type of oplock determining what type of caching is allowed. An oplock is not necessarily held until a client is finished with the file, and it may be broken at any time if the server receives an operation that is incompatible with the existing granted locks. This implies that the client must be able to quickly react to the break of the oplock and change its caching strategy dynamically.

Prior to SMB 2.1, there were four types of oplocks:

- **Level 1, exclusive access** This lock allows a client to open a file for exclusive access. The client may perform read-ahead buffering and read or write caching.
- **Level 2, shared access** This lock allows multiple, simultaneous readers of a file and no writers. The client may perform read-ahead buffering and read caching of file data and attributes. A write to the file will cause the holders of the lock to be notified that the lock has been broken.

- **Batch, exclusive access** This lock takes its name from the locking used when processing batch (.bat) files, which are opened and closed to process each line within the file. The client may keep a file open on the server, even though the application has (perhaps temporarily) closed the file. This lock supports read, write, and handle caching.
- **Filter, exclusive access** This lock provides applications and file system filters with a mechanism to give up the lock when other clients try to access the same file, but unlike a Level 2 lock, the file cannot be opened for delete access, and the other client will not receive a sharing violation. This lock supports read and write caching.

In the simplest terms, if multiple client systems are all caching the same file shared by a server, then as long as every application accessing the file (from any client or the server) tries only to read the file, those reads can be satisfied from each system's local cache. This drastically reduces the network traffic because the contents of the file aren't sent to each system from the server. Locking information must still be exchanged between the client systems and the server, but this requires very low network bandwidth. However, if even one of the clients opens the file for read *and* write access (or exclusive write), then none of the clients can use their local caches and all I/O to the file must go immediately to the server, *even if the file is never written*. (Lock modes are based upon how the file is opened, not individual I/O requests.)

An example, shown in Figure 11-19, will help illustrate oplock operation. The server automatically grants a Level 1 oplock to the first client to open a server file for access. The redirector on the client caches the file data for both reads and writes in the file cache of the client machine. If a second client opens the file, it too requests a Level 1 oplock. However, because there are now two clients accessing the same file, the server must take steps to present a consistent view of the file's data to both clients. If the first client has written to the file, as is the case in Figure 11-19, the server revokes its oplock and grants neither client an oplock. When the first client's oplock is revoked, or *broken*, the client flushes any data it has cached for the file back to the server.

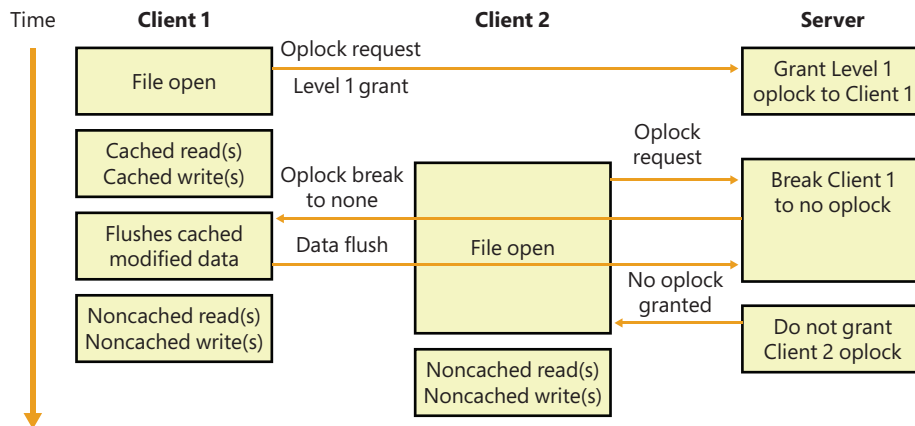
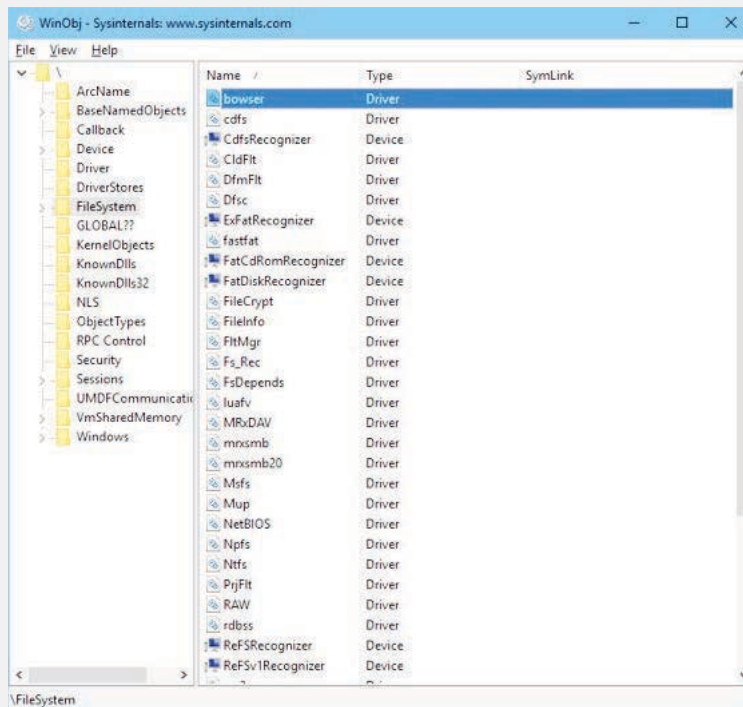

FIGURE 11-19 Oplock example.

If the first client hadn't written to the file, the first client's oplock would have been broken to a Level 2 oplock, which is the same type of oplock the server would grant to the second client. Now both clients can cache reads, but if either writes to the file, the server revokes their oplocks so that non-cached operation commences. Once oplocks are broken, they aren't granted again for the same open instance of a file. However, if a client closes a file and then reopens it, the server reassesses what level of oplock to grant the client based on which other clients have the file open and whether at least one of them has written to the file.

EXPERIMENT: Viewing the list of registered file systems

When the I/O manager loads a device driver into memory, it typically names the driver object it creates to represent the driver so that it's placed in the \Driver object manager directory. The driver objects for any driver the I/O manager loads that have a Type attribute value of `SERVICE_FILE_SYSTEM_DRIVER` (2) are placed in the \FileSystem directory by the I/O manager. Thus, using a tool such as WinObj (from Sysinternals), you can see the file systems that have registered on a system, as shown in the following screenshot. Note that file system *filter drivers* will also show up in this list. Filter drivers are described later in this section.



Another way to see registered file systems is to run the System Information viewer. Run `Msiinfo32` from the **Start** menu's **Run** dialog box and select **System Drivers** under **Software Environment**. Sort the list of drivers by clicking the Type column, and drivers with a Type attribute of `SERVICE_FILE_SYSTEM_DRIVER` group together.

Name	Description	File	Type	Started	Start
browser	browser	c:\windows\system32\drivers\browser.sys	File System Driver	Yes	Man
cdfs	CD/DVD File System Reader	c:\windows\system32\drivers\cdfs.sys	File System Driver	Yes	Disa
cldfilt	Windows Cloud Files Filter Driv...	c:\windows\system32\drivers\cldfilt.sys	File System Driver	Yes	Autc
dfmflt	DfmFit	c:\windows\system32\drivers\dfmflt.sys	File System Driver	Yes	Syst
dfsc	DFS Namespace Client Driver	c:\windows\system32\drivers\dfsc.sys	File System Driver	Yes	Syst
exfat	exFAT File System Driver	c:\windows\system32\drivers\exfat.sys	File System Driver	No	Man
fastfat	FAT12/16/32 File System Driver	c:\windows\system32\drivers\fastfat.sys	File System Driver	Yes	Man
filecrypt	FileCrypt	c:\windows\system32\drivers\filecrypt.sys	File System Driver	Yes	Syst
fileinfo	File Information FS MiniFilter	c:\windows\system32\drivers\fileinfo.sys	File System Driver	Yes	Bool
filetrace	Filetrace	c:\windows\system32\drivers\filetrace.sys	File System Driver	No	Man
fitmgr	FitMgr	c:\windows\system32\drivers\fitmgr.sys	File System Driver	Yes	Bool
fsdepends	File System Dependency Minifi...	c:\windows\system32\drivers\fsdepends.sys	File System Driver	Yes	Man
luafv	UAC File Virtualization	c:\windows\system32\drivers\luafv.sys	File System Driver	Yes	Autc
mrxdav	WebDav Client Redirector Driver	c:\windows\system32\drivers\mrxdav.sys	File System Driver	Yes	Man
mrxsmb	SMB MiniRedirector Wrapper ...	c:\windows\system32\drivers\mrxsmb.sys	File System Driver	Yes	Man
mrxsmb20	SMB 2.0 MiniRedirector	c:\windows\system32\drivers\mrxsmb20.sys	File System Driver	Yes	Man
msfs	MsfS	c:\windows\system32\drivers\msfs.sys	File System Driver	Yes	Syst
mup	Mup	c:\windows\system32\drivers\mup.sys	File System Driver	Yes	Boot
netbios	NetBIOS interface	c:\windows\system32\drivers\netbios.sys	File System Driver	Yes	Syst
npfs	Npfs	c:\windows\system32\drivers\npfs.sys	File System Driver	Yes	Syst
ntfs	Ntfs	c:\windows\system32\drivers\ntfs.sys	File System Driver	Yes	Man
prjflt	Windows Projected File System	c:\windows\system32\drivers\prjflt.sys	File System Driver	Yes	Man
rdboss	Redirected Buffering Sub Syste...	c:\windows\system32\drivers\rdboss.sys	File System Driver	Yes	Syst
refs	ReFS	c:\windows\system32\drivers\refs.sys	File System Driver	No	Man
refsv1	ReFSv1	c:\windows\system32\drivers\refsv1.sys	File System Driver	No	Man
smbdirect	smbdirect	c:\windows\system32\drivers\smbdirect.sys	File System Driver	No	Man
srv2	Server SMB 2.0xx Driver	c:\windows\system32\drivers\srv2.sys	File System Driver	Yes	Man
srvmnet	srvmnet	c:\windows\system32\drivers\srvmnet.sys	File System Driver	Yes	Man
storqosflt	Storage QoS Filter Driver	c:\windows\system32\drivers\storqosflt.sys	File System Driver	Yes	Autc

Note that just because a driver registers as a file system driver type doesn't mean that it is a local or remote FSD. For example, Npfs (Named Pipe File System) is a driver that implements named pipes through a file system-like private namespace. As mentioned previously, this list will also include file system filter drivers.

Leases Prior to SMB 2.1, the SMB protocol assumed an error-free network connection between the client and the server and did not tolerate network disconnections caused by transient network failures, server reboot, or cluster failovers. When a network disconnect event was received by the client, it orphaned all handles opened to the affected server(s), and all subsequent I/O operations on the orphaned handles were failed. Similarly, the server would release all opened handles and resources associated with the disconnected user session. This behavior resulted in applications losing state and in unnecessary network traffic.

In SMB 2.1, the concept of a *lease* is introduced as a new type of client caching mechanism, similar to an oplock. The purpose of a lease and an oplock is the same, but a lease provides greater flexibility and much better performance.

- **Read (R), shared access** Allows *multiple* simultaneous readers of a file, and no writers. This lease allows the client to perform read-ahead buffering and read caching.
- **Read-Handle (RH), shared access** This is similar to the Level 2 oplock, with the added benefit of allowing the client to keep a file open on the server even though the accessor on the client has closed the file. (The cache manager will lazily flush the unwritten data and purge the unmodified cache pages based on memory availability.) This is superior to a Level 2 oplock because the lease does not need to be broken between opens and closes of the file handle. (In this respect, it provides semantics similar to the Batch oplock.) This type of lease is especially useful for files that are repeatedly opened and closed because the cache is not invalidated when the file is closed and refilled when the file is opened again, providing a big improvement in performance for complex I/O intensive applications.
- **Read-Write (RW), exclusive access** This lease allows a client to open a file for exclusive access. This lock allows the client to perform read-ahead buffering and read or write caching.
- **Read-Write-Handle (RWH), exclusive access** This lock allows a client to open a file for exclusive access. This lease supports read, write, and handle caching (similar to the Read-Handle lease).

Another advantage that a lease has over an oplock is that a file may be cached, even when there are multiple handles opened to the file on the client. (This is a common behavior in many applications.) This is implemented through the use of a lease *key* (implemented using a GUID), which is created by the client and associated with the File Control Block (FCB) for the cached file, allowing all handles to the same file to share the same lease state, which provides caching by file rather than caching by handle. Prior to the introduction of the lease, the oplock was broken whenever a new handle was opened to the file, even from the same client. Figure 11-20 shows the oplock behavior, and Figure 11-21 shows the new lease behavior.

Prior to SMB 2.1, oplocks could only be granted or broken, but leases can also be *converted*. For example, a Read lease may be converted to a Read-Write lease, which greatly reduces network traffic because the cache for a particular file does not need to be invalidated and refilled, as would be the case with an oplock break (of the Level 2 oplock), followed by the request and grant of a Level 1 oplock.

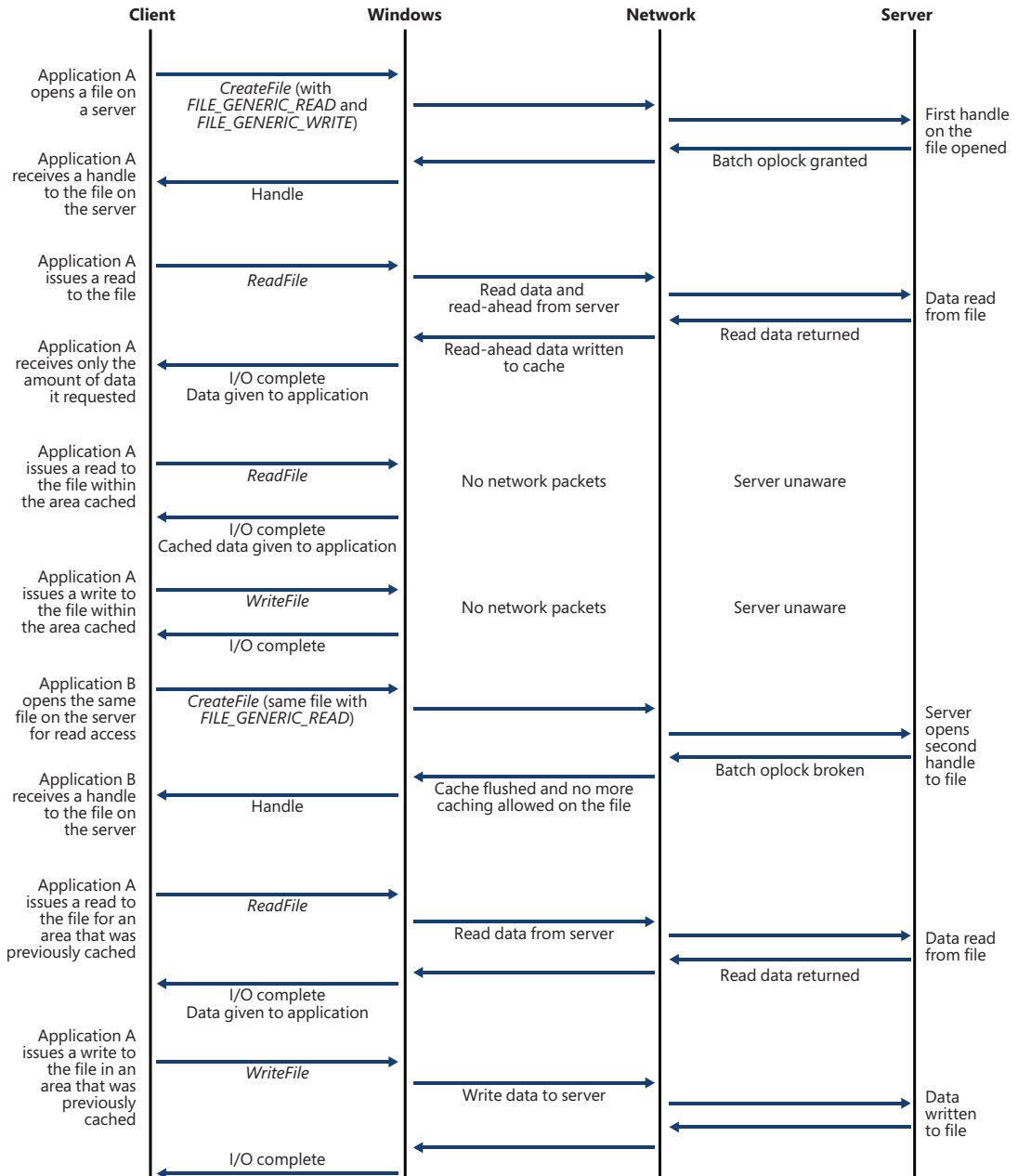

FIGURE 11-20 Oplock with multiple handles from the same client.

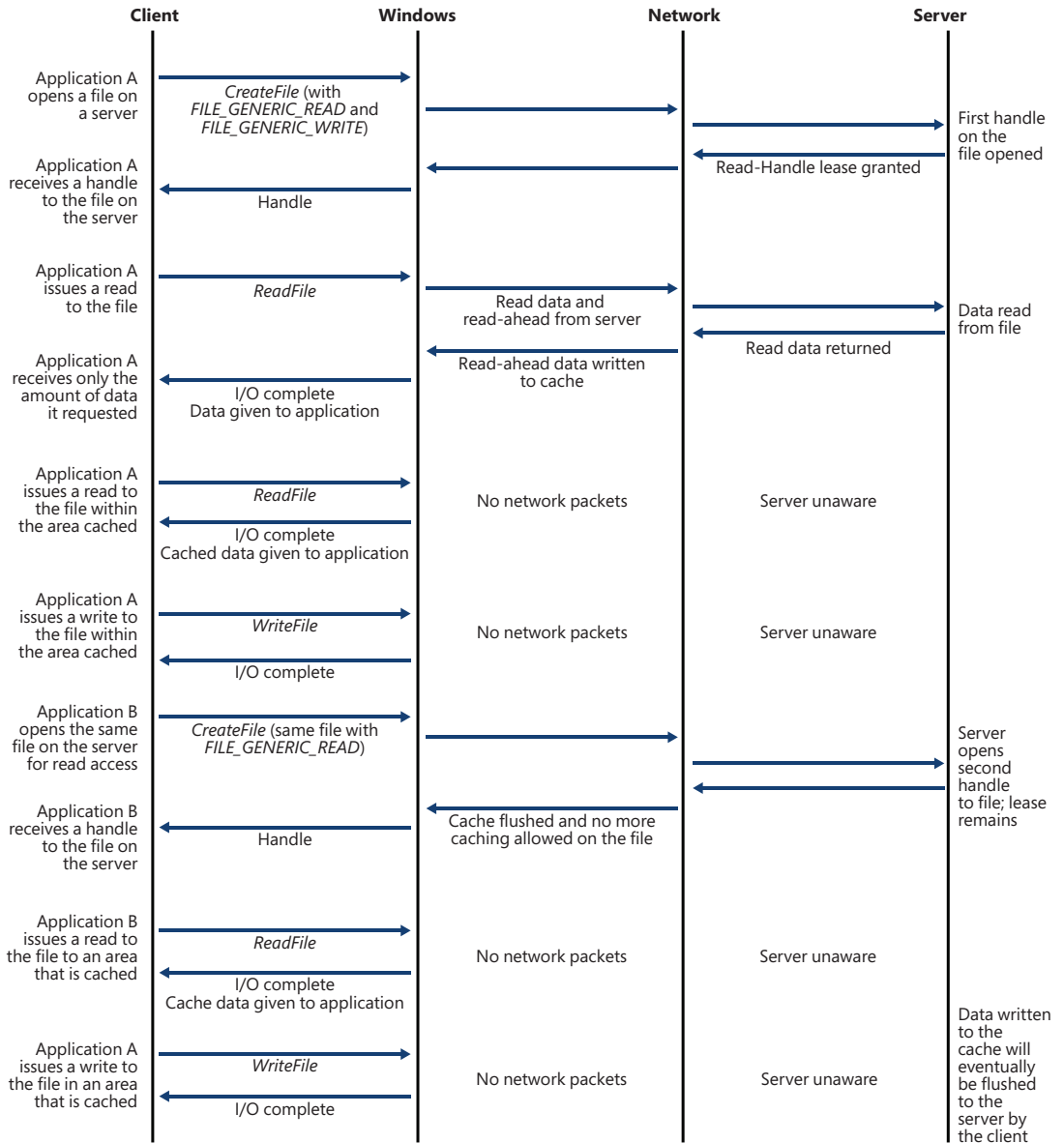

FIGURE 11-21 Lease with multiple handles from the same client.

File system operations

Applications and the system access files in two ways: directly, via file I/O functions (such as *ReadFile* and *WriteFile*), and indirectly, by reading or writing a portion of their address space that represents a mapped file section. (See Chapter 5 of Part 1 for more information on mapped files.) Figure 11-22 is a simplified diagram that shows the components involved in these file system operations and the ways in which they interact. As you can see, an FSD can be invoked through several paths:

- From a user or system thread performing explicit file I/O
- From the memory manager's modified and mapped page writers
- Indirectly from the cache manager's lazy writer
- Indirectly from the cache manager's read-ahead thread
- From the memory manager's page fault handler

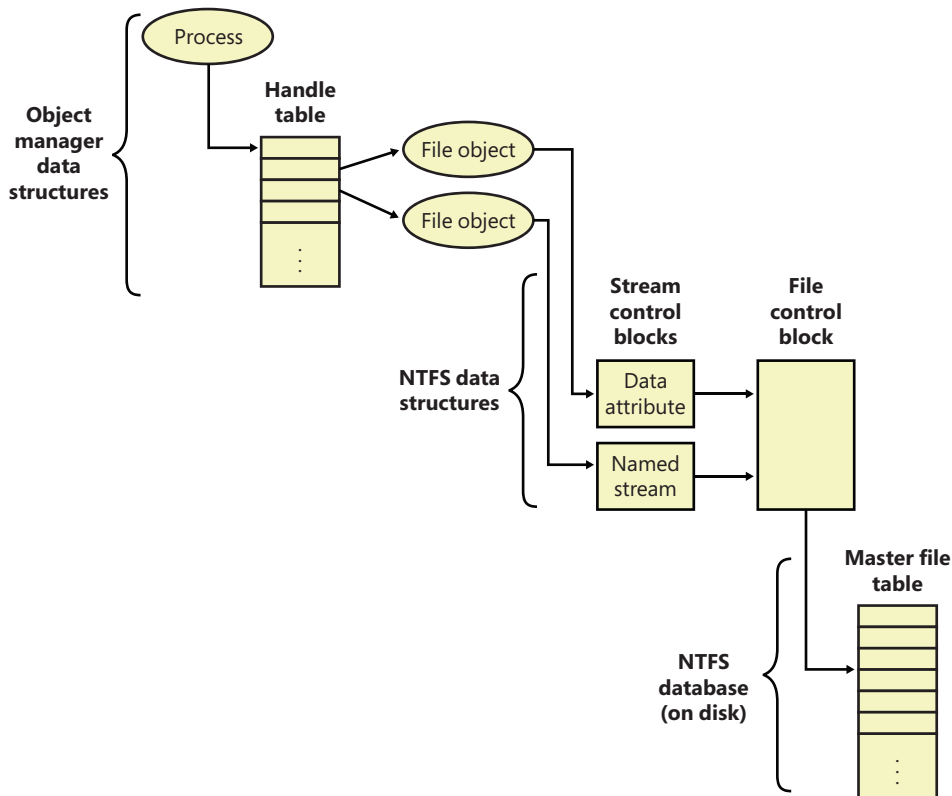

FIGURE 11-22 Components involved in file system I/O.

The following sections describe the circumstances surrounding each of these scenarios and the steps FSDs typically take in response to each one. You'll see how much FSDs rely on the memory manager and the cache manager.

Explicit file I/O

The most obvious way an application accesses files is by calling Windows I/O functions such as *CreateFile*, *ReadFile*, and *WriteFile*. An application opens a file with *CreateFile* and then reads, writes, or deletes the file by passing the handle returned from *CreateFile* to other Windows functions. The *CreateFile* function, which is implemented in the Kernel32.dll Windows client-side DLL, invokes the native function *NtCreateFile*, forming a complete root-relative path name for the path that the application passed to it (processing “.” and “..” symbols in the path name) and prefixing the path with “\?” (for example, \?\C:\Daryl\Todo.txt).

The *NtCreateFile* system service uses *ObOpenObjectByName* to open the file, which parses the name starting with the object manager root directory and the first component of the path name (“?”). Chapter 8, “System mechanisms”, includes a thorough description of object manager name resolution and its use of process device maps, but we’ll review the steps it follows here with a focus on volume drive letter lookup.

The first step the object manager takes is to translate \? to the process’s per-session namespace directory that the *DosDevicesDirectory* field of the device map structure in the process object references (which was propagated from the first process in the logon session by using the logon session references field in the logon session’s token). Only volume names for network shares and drive letters mapped by the Subst.exe utility are typically stored in the per-session directory, so on those systems when a name (C: in this example) is not present in the per-session directory, the object manager restarts its search in the directory referenced by the *GlobalDosDevicesDirectory* field of the device map associated with the per-session directory. The *GlobalDosDevicesDirectory* field always points at the \GLOBAL?? directory, which is where Windows stores volume drive letters for local volumes. (See the section “Session namespace” in Chapter 8 for more information.) Processes can also have their own device map, which is an important characteristic during impersonation over protocols such as RPC.

The symbolic link for a volume drive letter points to a volume device object under \Device, so when the object manager encounters the volume object, the object manager hands the rest of the path name to the parse function that the I/O manager has registered for device objects, *IopParseDevice*. (In volumes on dynamic disks, a symbolic link points to an intermediary symbolic link, which points to a volume device object.) Figure 11-23 shows how volume objects are accessed through the object manager namespace. The figure shows how the \GLOBAL??\C: symbolic link points to the \Device\HarddiskVolume6 volume device object.

After locking the caller’s security context and obtaining security information from the caller’s token, *IopParseDevice* creates an I/O request packet (IRP) of type *IRP_MJ_CREATE*, creates a file object that stores the name of the file being opened, follows the VPB of the volume device object to find the volume’s mounted file system device object, and uses *IoCallDriver* to pass the IRP to the file system driver that owns the file system device object.

When an FSD receives an *IRP_MJ_CREATE* IRP, it looks up the specified file, performs security validation, and if the file exists and the user has permission to access the file in the way requested, returns a success status code. The object manager creates a handle for the file object in the process’s handle table, and the handle propagates back through the calling chain, finally reaching the application as a

return parameter from *CreateFile*. If the file system fails the create operation, the I/O manager deletes the file object it created for the file.

We've skipped over the details of how the FSD locates the file being opened on the volume, but a *ReadFile* function call operation shares many of the FSD's interactions with the cache manager and storage driver. Both *ReadFile* and *CreateFile* are system calls that map to I/O manager functions, but the *NtReadFile* system service doesn't need to perform a name lookup; it calls on the object manager to translate the handle passed from *ReadFile* into a file object pointer. If the handle indicates that the caller obtained permission to read the file when the file was opened, *NtReadFile* proceeds to create an IRP of type *IRP_MJ_READ* and sends it to the FSD for the volume on which the file resides. *NtReadFile* obtains the FSD's device object, which is stored in the file object, and calls *IoCallDriver*, and the I/O manager locates the FSD from the device object and gives the IRP to the FSD.

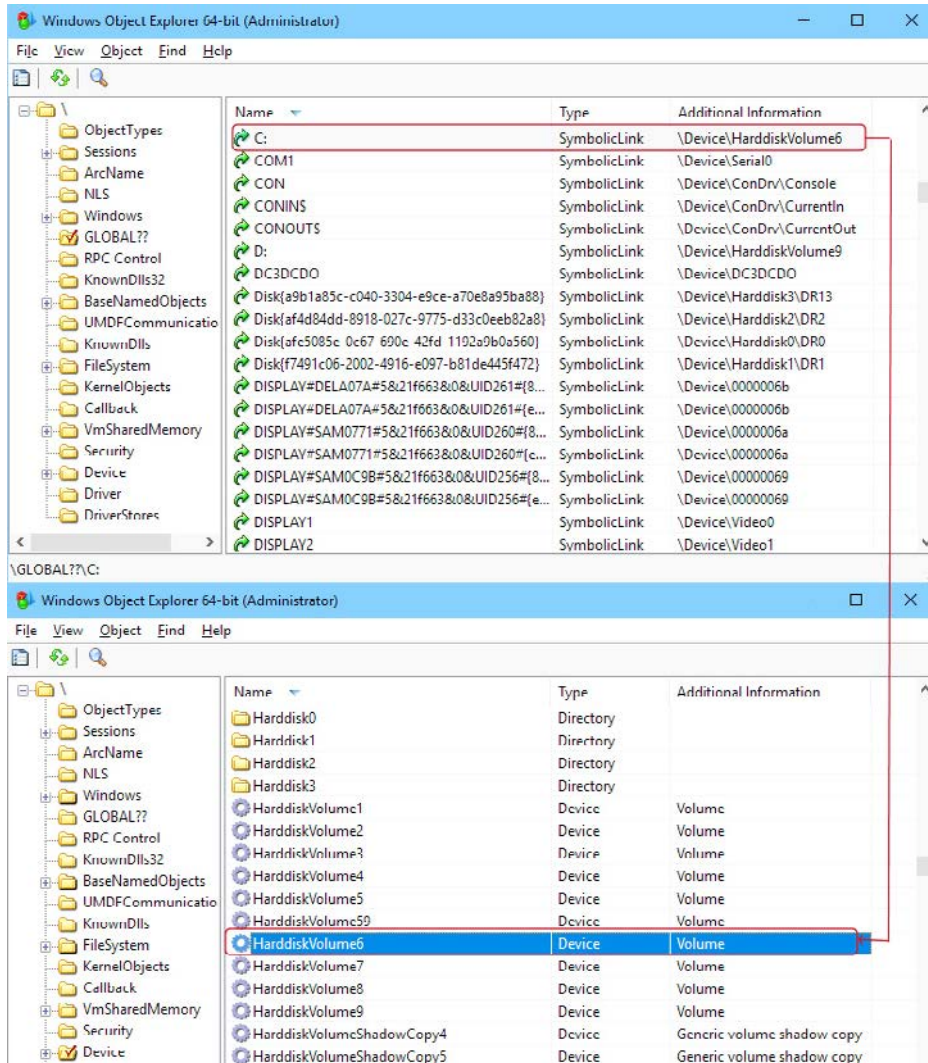

FIGURE 11-23 Drive-letter name resolution.

If the file being read can be cached (that is, the *FILE_FLAG_NO_BUFFERING* flag wasn't passed to *CreateFile* when the file was opened), the FSD checks to see whether caching has already been initiated for the file object. The *PrivateCacheMap* field in a file object points to a private cache map data structure (which we described in the previous section) if caching is initiated for a file object. If the FSD hasn't initialized caching for the file object (which it does the first time a file object is read from or written to), the *PrivateCacheMap* field will be null. The FSD calls the cache manager's *CcInitializeCacheMap* function to initialize caching, which involves the cache manager creating a private cache map and, if another file object referring to the same file hasn't initiated caching, a shared cache map and a section object.

After it has verified that caching is enabled for the file, the FSD copies the requested file data from the cache manager's virtual memory to the buffer that the thread passed to the *ReadFile* function. The file system performs the copy within a try/except block so that it catches any faults that are the result of an invalid application buffer. The function the file system uses to perform the copy is the cache manager's *CcCopyRead* function. *CcCopyRead* takes as parameters a file object, file offset, and length.

When the cache manager executes *CcCopyRead*, it retrieves a pointer to a shared cache map, which is stored in the file object. Recall that a shared cache map stores pointers to virtual address control blocks (VACBs), with one VACB entry for each 256 KB block of the file. If the VACB pointer for a portion of a file being read is null, *CcCopyRead* allocates a VACB, reserving a 256 KB view in the cache manager's virtual address space, and maps (using *MmMapViewInSystemCache*) the specified portion of the file into the view. Then *CcCopyRead* simply copies the file data from the mapped view to the buffer it was passed (the buffer originally passed to *ReadFile*). If the file data isn't in physical memory, the copy operation generates page faults, which are serviced by *MmAccessFault*.

When a page fault occurs, *MmAccessFault* examines the virtual address that caused the fault and locates the virtual address descriptor (VAD) in the VAD tree of the process that caused the fault. (See Chapter 5 of Part 1 for more information on VAD trees.) In this scenario, the VAD describes the cache manager's mapped view of the file being read, so *MmAccessFault* calls *MiDispatchFault* to handle a page fault on a valid virtual memory address. *MiDispatchFault* locates the control area (which the VAD points to) and through the control area finds a file object representing the open file. (If the file has been opened more than once, there might be a list of file objects linked through pointers in their private cache maps.)

With the file object in hand, *MiDispatchFault* calls the I/O manager function *IoPageRead* to build an IRP (of type *IRP_MJ_READ*) and sends the IRP to the FSD that owns the device object the file object points to. Thus, the file system is reentered to read the data that it requested via *CcCopyRead*, but this time the IRP is marked as noncached and paging I/O. These flags signal the FSD that it should retrieve file data directly from disk, and it does so by determining which clusters on disk contain the requested data (the exact mechanism is file-system dependent) and sending IRPs to the volume manager that owns the volume device object on which the file resides. The volume parameter block (VPB) field in the FSD's device object points to the volume device object.

The memory manager waits for the FSD to complete the IRP read and then returns control to the cache manager, which continues the copy operation that was interrupted by a page fault. When *CcCopyRead* completes, the FSD returns control to the thread that called *NtReadFile*, having copied the requested file data, with the aid of the cache manager and the memory manager, to the thread's buffer.

The path for *WriteFile* is similar except that the *NtWriteFile* system service generates an IRP of type *IRP_MJ_WRITE*, and the FSD calls *CcCopyWrite* instead of *CcCopyRead*. *CcCopyWrite*, like *CcCopyRead*, ensures that the portions of the file being written are mapped into the cache and then copies to the cache the buffer passed to *WriteFile*.

If a file's data is already cached (in the system's working set), there are several variants on the scenario we've just described. If a file's data is already stored in the cache, *CcCopyRead* doesn't incur page faults. Also, under certain conditions, *NtReadFile* and *NtWriteFile* call an FSD's fast I/O entry point instead of immediately building and sending an IRP to the FSD. Some of these conditions follow: the portion of the file being read must reside in the first 4 GB of the file, the file can have no locks, and the portion of the file being read or written must fall within the file's currently allocated size.

The fast I/O read and write entry points for most FSDs call the cache manager's *CcFastCopyRead* and *CcFastCopyWrite* functions. These variants on the standard copy routines ensure that the file's data is mapped in the file system cache before performing a copy operation. If this condition isn't met, *CcFastCopyRead* and *CcFastCopyWrite* indicate that fast I/O isn't possible. When fast I/O isn't possible, *NtReadFile* and *NtWriteFile* fall back on creating an IRP. (See the earlier section "Fast I/O" for a more complete description of fast I/O.)

Memory manager's modified and mapped page writer

The memory manager's modified and mapped page writer threads wake up periodically (and when available memory runs low) to flush modified pages to their backing store on disk. The threads call *IoAsynchronousPageWrite* to create IRPs of type *IRP_MJ_WRITE* and write pages to either a paging file or a file that was modified after being mapped. Like the IRPs that *MiDispatchFault* creates, these IRPs are flagged as noncached and paging I/O. Thus, an FSD bypasses the file system cache and issues IRPs directly to a storage driver to write the memory to disk.

Cache manager's lazy writer

The cache manager's lazy writer thread also plays a role in writing modified pages because it periodically flushes views of file sections mapped in the cache that it knows are dirty. The flush operation, which the cache manager performs by calling *MmFlushSection*, triggers the memory manager to write any modified pages in the portion of the section being flushed to disk. Like the modified and mapped page writers, *MmFlushSection* uses *IoSynchronousPageWrite* to send the data to the FSD.

Cache manager's read-ahead thread

A cache uses two artifacts of how programs reference code and data: temporal locality and spatial locality. The underlying concept behind temporal locality is that if a memory location is referenced, it is likely to be referenced again soon. The idea behind spatial locality is that if a memory location is referenced, other nearby locations are also likely to be referenced soon. Thus, a cache typically is very good at speeding up access to memory locations that have been accessed in the near past, but it's terrible at speeding up access to areas of memory that have not yet been accessed (it has zero lookahead

capability). In an attempt to populate the cache with data that will likely be used soon, the cache manager implements two mechanisms: a read-ahead thread and Superfetch.

As we described in the previous section, the cache manager includes a thread that is responsible for attempting to read data from files before an application, a driver, or a system thread explicitly requests it. The read-ahead thread uses the history of read operations that were performed on a file, which are stored in a file object's private cache map, to determine how much data to read. When the thread performs a read-ahead, it simply maps the portion of the file it wants to read into the cache (allocating VACBs as necessary) and touches the mapped data. The page faults caused by the memory accesses invoke the page fault handler, which reads the pages into the system's working set.

A limitation of the read-ahead thread is that it works only on open files. Superfetch was added to Windows to proactively add files to the cache before they're even opened. Specifically, the memory manager sends page-usage information to the Superfetch service (%SystemRoot%\System32\Sysmain.dll), and a file system minifilter provides file name resolution data. The Superfetch service attempts to find file-usage patterns—for example, payroll is run every Friday at 12:00, or Outlook is run every morning at 8:00. When these patterns are derived, the information is stored in a database and timers are requested. Just prior to the time the file would most likely be used, a timer fires and tells the memory manager to read the file into low-priority memory (using low-priority disk I/O). If the file is then opened, the data is already in memory, and there's no need to wait for the data to be read from disk. If the file isn't opened, the low-priority memory will be reclaimed by the system. The internals and full description of the Superfetch service were previously described in Chapter 5, Part 1.

Memory manager's page fault handler

We described how the page fault handler is used in the context of explicit file I/O and cache manager read-ahead, but it's also invoked whenever any application accesses virtual memory that is a view of a mapped file and encounters pages that represent portions of a file that aren't yet in memory. The memory manager's *MmAccessFault* handler follows the same steps it does when the cache manager generates a page fault from *CcCopyRead* or *CcCopyWrite*, sending IRPs via *IoPageRead* to the file system on which the file is stored.

File system filter drivers and minifilters

A filter driver that layers over a file system driver is called a *file system filter driver*. Two types of file system filter drivers are supported by the Windows I/O model:

- Legacy file system filter drivers usually create one or multiple device objects and attach them on the file system device through the *IoAttachDeviceToDeviceStack* API. Legacy filter drivers intercept all the requests coming from the cache manager or I/O manager and must implement both standard IRP dispatch functions and the Fast I/O path. Due to the complexity involved in the development of this kind of driver (synchronization issues, undocumented interfaces, dependency on the original file system, and so on), Microsoft has developed a unified filter model that makes use of special drivers, called minifilters, and deprecated legacy file system drivers. (The *IoAttachDeviceToDeviceStack* API fails when it's called for DAX volumes).

- Minifilter drivers are clients of the Filesystem Filter Manager (FltMgr.sys). The Filesystem Filter Manager is a legacy file system filter driver that provides a rich and documented interface for the creation of file system filters, hiding the complexity behind all the interactions between the file system drivers and the cache manager. Minifilters register with the filter manager through the *FltRegisterFilter* API. The caller usually specifies an instance setup routine and different operation callbacks. The instance setup is called by the filter manager for every valid volume device that a file system manages. The minifilter has the chance to decide whether to attach to the volume. Minifilters can specify a Pre and Post operation callback for every major IRP function code, as well as certain “pseudo-operations” that describe internal memory manager or cache manager semantics that are relevant to file system access patterns. The Pre callback is executed before the I/O is processed by the file system driver, whereas the Post callback is executed after the I/O operation has been completed. The Filter Manager also provides its own communication facility that can be employed between minifilter drivers and their associated user-mode application.

The ability to see all file system requests and optionally modify or complete them enables a range of applications, including remote file replication services, file encryption, efficient backup, and licensing. Every anti-malware product typically includes at least a minifilter driver that intercepts applications opening or modifying files. For example, before propagating the IRP to the file system driver to which the command is directed, a malware scanner examines the file being opened to ensure that it’s clean. If the file is clean, the malware scanner passes the IRP on, but if the file is infected, the malware scanner quarantines or cleans the file. If the file can’t be cleaned, the driver fails the IRP (typically with an access-denied error) so that the malware cannot become active.

Deeply describing the entire minifilter and legacy filter driver architecture is outside the scope of this chapter. You can find more information on the legacy filter driver architecture in Chapter 6, “I/O System,” of Part 1. More details on minifilters are available in MSDN (<https://docs.microsoft.com/en-us/windows-hardware/drivers/ifs/file-system-minifilter-drivers>).

Data-scan sections

Starting with Windows 8.1, the Filter Manager collaborates with file system drivers to provide data-scan section objects that can be used by anti-malware products. Data-scan section objects are similar to standard section objects (for more information about section objects, see Chapter 5 of Part 1) except for the following:

- Data-scan section objects can be created from minifilter callback functions, namely from callbacks that manage the *IRP_MJ_CREATE* function code. These callbacks are called by the filter manager when an application is opening or creating a file. An anti-malware scanner can create a data-scan section and then start scanning before completing the callback.
- *FltCreateSectionForDataScan*, the API used for creating data-scan sections, accepts a *FILE_OBJECT* pointer. This means that callers don’t need to provide a file handle. The file handle typically doesn’t yet exist, and would thus need to be (re)created by using *FltCreateFile* API, which would then have created other file creation IRPs, recursively interacting with lower level file system filters once again. With the new API, the process is much faster because these extra recursive calls won’t be generated.

A data-scan section can be mapped like a normal section using the traditional API. This allows anti-malware applications to implement their scan engine either as a user-mode application or in a kernel-mode driver. When the data-scan section is mapped, *IRP_MJ_READ* events are still generated in the minifilter driver, but this is not a problem because the minifilter doesn't have to include a read callback at all.

Filtering named pipes and mailslots

When a process belonging to a user application needs to communicate with another entity (a process, kernel driver, or remote application), it can leverage facilities provided by the operating system. The most traditionally used are named pipes and mailslots, because they are portable among other operating systems as well. A named pipe is a named, one-way communication channel between a pipe server and one or more pipe clients. All instances of a named pipe share the same pipe name, but each instance has its own buffers and handles, and provides a separate channel for client/server communication. Named pipes are implemented through a file system driver, the NPFS driver (Npfs.sys).

A mailslot is a multi-way communication channel between a mailslot server and one or more clients. A mailslot server is a process that creates a mailslot through the *CreateMailslot* Win32 API, and can only read small messages (424 bytes maximum when sent between remote computers) generated by one or more clients. Clients are processes that write messages to the mailslot. Clients connect to the mailslot through the standard *CreateFile* API and send messages through the *WriteFile* function. Mailslots are generally used for broadcasting messages within a domain. If several server processes in a domain each create a mailslot using the same name, every message that is addressed to that mailslot and sent to the domain is received by the participating processes. Mailslots are implemented through the Mailslot file system driver, Msfs.sys.

Both the mailslot and NPFS driver implement simple file systems. They manage namespaces composed of files and directories, which support security, can be opened, closed, read, written, and so on. Describing the implementation of the two drivers is outside the scope of this chapter.

Starting with Windows 8, mailslots and named pipes are supported by the Filter Manager. Minifilters are able to attach to the mailslot and named pipe volumes (*\Device\NamedPipe* and *\Device\Mailslot*, which are not real volumes), through the *FLTFL_REGISTRATION_SUPPORT_NPFS_MSFS* flag specified at registration time. A minifilter can then intercept and modify all the named pipe and mailslot I/O that happens between local and remote process and between a user application and its kernel driver. Furthermore, minifilters can open or create a named pipe or mailslot without generating recursive events through the *FltCreateNamedPipeFile* or *FltCreateMailslotFile* APIs.



Note One of the motivations that explains why the named pipe and mailslot file system drivers are simpler compared to NTFS and ReFs is that they do not interact heavily with the cache manager. The named pipe driver implements the Fast I/O path but with no cached read or write-behind support. The mailslot driver does not interact with the cache manager at all.

Controlling reparse point behavior

The NTFS file system supports the concept of *reparse points*, blocks of 16 KB of application and system-defined reparse data that can be associated to single files. (Reparse points are discussed more in multiple sections later in this chapter.) Some types of reparse points, like volume mount points or symbolic links, contain a link between the original file (or an empty directory), used as a placeholder, and another file, which can even be located in another volume. When the NTFS file system driver encounters a reparse point on its path, it returns an error code to the upper driver in the device stack. The latter (which could be another filter driver) analyzes the reparse point content and, in the case of a symbolic link, re-emits another I/O to the correct volume device.

This process is complex and cumbersome for any filter driver. Minifilter drivers can intercept the `STATUS_REPARSE` error code and reopen the reparse point through the new `FltCreateFileEx2` API, which accepts a list of Extra Create Parameters (also known as ECPs), used to fine-tune the behavior of the opening/creation process of a target file in the minifilter context. In general, the Filter Manager supports different ECPs, and each of them is uniquely identified by a GUID. The Filter Manager provides multiple documented APIs that deal with ECPs and ECP lists. Usually, minifilters allocate an ECP with the `FltAllocateExtraCreateParameter` function, populate it, and insert it into a list (through `FltInsertExtraCreateParameter`) before calling the Filter Manager's I/O APIs.

The `FLT_CREATEFILE_TARGET` extra creation parameter allows the Filter Manager to manage cross-volume file creation automatically (the caller needs to specify a flag). Minifilters don't need to perform any other complex operation.

With the goal of supporting container isolation, it's also possible to set a reparse point on nonempty directories and, in order to support container isolation, create new files that have directory reparse points. The default behavior that the file system has while encountering a nonempty directory reparse point depends on whether the reparse point is applied in the last component of the file full path. If this is the case, the file system returns the `STATUS_REPARSE` error code, just like for an empty directory; otherwise, it continues to walk the path.

The Filter Manager is able to correctly deal with this new kind of reparse point through another ECP (named `TYPE_OPEN_REPARSE`). The ECP includes a list of descriptors (`OPEN_REPARSE_LIST_ENTRY` data structure), each of which describes the type of reparse point (through its Reparse Tag), and the behavior that the system should apply when it encounters a reparse point of that type while parsing a path. Minifilters, after they have correctly initialized the descriptor list, can apply the new behavior in different ways:

- Issue a new open (or create) operation on a file that resides in a path that includes a reparse point in any of its components, using the `FltCreateFileEx2` function. This procedure is similar to the one used by the `FLT_CREATEFILE_TARGET` ECP.
- Apply the new reparse point behavior globally to any file that the Pre-Create callback intercepts. The `FltAddOpenReparseEntry` and `FltRemoveOpenReparseEntry` APIs can be used to set the reparse point behavior to a target file before the file is actually created (the pre-creation callback intercepts the file creation request before the file is created). The Windows Container Isolation minifilter driver (`Wcifs.sys`) uses this strategy.

Process Monitor

Process Monitor (Procmon), a system activity-monitoring utility from Sysinternals that has been used throughout this book, is an example of a passive minifilter driver, which is one that does not modify the flow of IRPs between applications and file system drivers.

Process Monitor works by extracting a file system minifilter device driver from its executable image (stored as a resource inside Procmon.exe) the first time you run it after a boot, installing the driver in memory, and then deleting the driver image from disk (unless configured for persistent boot-time monitoring). Through the Process Monitor GUI, you can direct the driver to monitor file system activity on local volumes that have assigned drive letters, network shares, named pipes, and mail slots. When the driver receives a command to start monitoring a volume, it registers filtering callbacks with the Filter Manager, which is attached to the device object that represents a mounted file system on the volume. After an attach operation, the I/O manager redirects an IRP targeted at the underlying device object to the driver owning the attached device, in this case the Filter Manager, which sends the event to registered minifilter drivers, in this case Process Monitor.

When the Process Monitor driver intercepts an IRP, it records information about the IRP's command, including target file name and other parameters specific to the command (such as read and write lengths and offsets) to a nonpaged kernel buffer. Every 500 milliseconds, the Process Monitor GUI program sends an IRP to Process Monitor's interface device object, which requests a copy of the buffer containing the latest activity, and then displays the activity in its output window. Process Monitor shows all file activity as it occurs, which makes it an ideal tool for troubleshooting file system-related system and application failures. To run Process Monitor the first time on a system, an account must have the Load Driver and Debug privileges. After loading, the driver remains resident, so subsequent executions require only the Debug privilege.

When you run Process Monitor, it starts in basic mode, which shows the file system activity most often useful for troubleshooting. When in basic mode, Process Monitor omits certain file system operations from being displayed, including

- I/O to NTFS metadata files
- I/O to the paging file
- I/O generated by the System process
- I/O generated by the Process Monitor process

While in basic mode, Process Monitor also reports file I/O operations with friendly names rather than with the IRP types used to represent them. For example, both *IRP_MJ_WRITE* and *FASTIO_WRITE* operations display as *WriteFile*, and *IRP_MJ_CREATE* operations show as *Open* if they represent an open operation and as *Create* for the creation of new files.

EXPERIMENT: Viewing Process Monitor's minifilter driver

To see which file system minifilter drivers are loaded, start an Administrative command prompt, and run the Filter Manager control program (%SystemRoot%\System32\Fltmc.exe). Start Process Monitor (ProcMon.exe) and run Fltmc again. You see that the Process Monitor's filter driver (PROCMON20) is loaded and has a nonzero value in the Instances column. Now, exit Process Monitor and run Fltmc again. This time, you see that the Process Monitor's filter driver is still loaded, but now its instance count is zero.

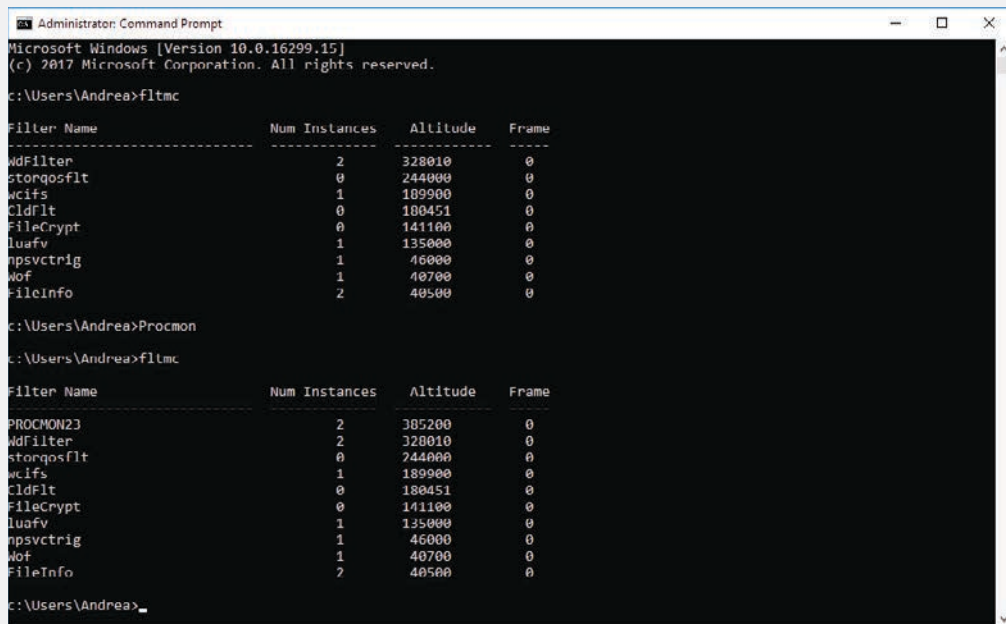

```
Administrator: Command Prompt
Microsoft Windows [Version 10.0.16299.15]
(c) 2017 Microsoft Corporation. All rights reserved.

c:\Users\Andrea>fltmc

Filter Name           Num Instances  Altitude  Frame
-----
WdFilter              2             328010    0
Storqosflt            0             244000    0
Wcifs                 1             189900    0
Clidflt              0             180451    0
FileCrypt             0             141100    0
Luafv                 1             135000    0
Npsvctrig            1              46000    0
Wof                  1              40700    0
FileInfo              2             40500     0

c:\Users\Andrea>Procmon

c:\Users\Andrea>fltmc

Filter Name           Num Instances  Altitude  Frame
-----
PROCMON23            2             385200    0
WdFilter              2             328010    0
Storqosflt            0             244000    0
Wcifs                 1             189900    0
Clidflt              0             180451    0
FileCrypt             0             141100    0
Luafv                 1             135000    0
Npsvctrig            1              46000    0
Wof                  1              40700    0
FileInfo              2             40500     0

c:\Users\Andrea>
```

The NT File System (NTFS)

In the following section, we analyze the internal architecture of the NTFS file system, starting by looking at the requirements that drove its design. We examine the on-disk data structures, and then we move on to the advanced features provided by the NTFS file system, like the Recovery support, tiered volumes, and the Encrypting File System (EFS).

High-end file system requirements

From the start, NTFS was designed to include features required of an enterprise-class file system. To minimize data loss in the face of an unexpected system outage or crash, a file system must ensure that the integrity of its metadata is guaranteed at all times; and to protect sensitive data from unauthorized access, a file system must have an integrated security model. Finally, a file system must allow for software-based data redundancy as a low-cost alternative to hardware-redundant solutions for protecting user data. In this section, you find out how NTFS implements each of these capabilities.

Recoverability

To address the requirement for reliable data storage and data access, NTFS provides file system recovery based on the concept of an *atomic transaction*. Atomic transactions are a technique for handling modifications to a database so that system failures don't affect the correctness or integrity of the database. The basic tenet of atomic transactions is that some database operations, called *transactions*, are all-or-nothing propositions. (A *transaction* is defined as an I/O operation that alters file system data or changes the volume's directory structure.) The separate disk updates that make up the transaction must be executed *atomically*—that is, once the transaction begins to execute, all its disk updates must be completed. If a system failure interrupts the transaction, the part that has been completed must be undone, or *rolled back*. The rollback operation returns the database to a previously known and consistent state, as if the transaction had never occurred.

NTFS uses atomic transactions to implement its file system recovery feature. If a program initiates an I/O operation that alters the structure of an NTFS volume—that is, changes the directory structure, extends a file, allocates space for a new file, and so on—NTFS treats that operation as an atomic transaction. It guarantees that the transaction is either completed or, if the system fails while executing the transaction, rolled back. The details of how NTFS does this are explained in the section “NTFS recovery support” later in the chapter. In addition, NTFS uses redundant storage for vital file system information so that if a sector on the disk goes bad, NTFS can still access the volume's critical file system data.

Security

Security in NTFS is derived directly from the Windows object model. Files and directories are protected from being accessed by unauthorized users. (For more information on Windows security, see Chapter 7, “Security,” in Part 1.) An open file is implemented as a file object with a security descriptor stored on disk in the hidden \$Secure metafile, in a stream named \$SDS (Security Descriptor Stream). Before a process can open a handle to any object, including a file object, the Windows security system verifies that the process has appropriate authorization to do so. The security descriptor, combined with the requirement that a user log on to the system and provide an identifying password, ensures that no process can access a file unless it is given specific permission to do so by a system administrator or by the file's owner. (For more information about security descriptors, see the section “Security descriptors and access control” in Chapter 7 in Part 1).

Data redundancy and fault tolerance

In addition to recoverability of file system data, some customers require that their data not be endangered by a power outage or catastrophic disk failure. The NTFS recovery capabilities ensure that the file system on a volume remains accessible, but they make no guarantees for complete recovery of user files. Protection for applications that can't risk losing file data is provided through data redundancy.

Data redundancy for user files is implemented via the Windows layered driver, which provides fault-tolerant disk support. NTFS communicates with a volume manager, which in turn communicates with a disk driver to write data to a disk. A volume manager can *mirror*, or duplicate, data from one disk onto another disk so that a redundant copy can always be retrieved. This support is commonly called

RAID level 1. Volume managers also allow data to be written in *stripes* across three or more disks, using the equivalent of one disk to maintain parity information. If the data on one disk is lost or becomes inaccessible, the driver can reconstruct the disk's contents by means of exclusive-OR operations. This support is called *RAID level 5*.

In Windows 7, data redundancy for NTFS implemented via the Windows layered driver was provided by Dynamic Disks. Dynamic Disks had multiple limitations, which have been overcome in Windows 8.1 by introducing a new technology that virtualizes the storage hardware, called Storage Spaces. Storage Spaces is able to create virtual disks that already provide data redundancy and fault tolerance. The volume manager doesn't differentiate between a virtual disk and a real disk (so user mode components can't see any difference between the two). The NTFS file system driver cooperates with Storage Spaces for supporting tiered disks and RAID virtual configurations. Storage Spaces and Spaces Direct will be covered later in this chapter.

Advanced features of NTFS

In addition to NTFS being recoverable, secure, reliable, and efficient for mission-critical systems, it includes the following advanced features that allow it to support a broad range of applications. Some of these features are exposed as APIs for applications to leverage, and others are internal features:

- Multiple data streams
- Unicode-based names
- General indexing facility
- Dynamic bad-cluster remapping
- Hard links
- Symbolic (soft) links and junctions
- Compression and sparse files
- Change logging
- Per-user volume quotas
- Link tracking
- Encryption
- POSIX support
- Defragmentation
- Read-only support and dynamic partitioning
- Tiered volume support

The following sections provide an overview of these features.

Multiple data streams

In NTFS, each unit of information associated with a file—including its name, its owner, its time stamps, its contents, and so on—is implemented as a file attribute (NTFS object attribute). Each attribute consists of a single *stream*—that is, a simple sequence of bytes. This generic implementation makes it easy to add more attributes (and therefore more streams) to a file. Because a file’s data is “just another attribute” of the file and because new attributes can be added, NTFS files (and file directories) can contain multiple data streams.

An NTFS file has one default data stream, which has no name. An application can create additional, named data streams and access them by referring to their names. To avoid altering the Windows I/O APIs, which take a string as a file name argument, the name of the data stream is specified by appending a colon (:) to the file name. Because the colon is a reserved character, it can serve as a separator between the file name and the data stream name, as illustrated in this example:

```
myfile.dat:stream2
```

Each stream has a separate allocation size (which defines how much disk space has been reserved for it), actual size (which is how many bytes the caller has used), and valid data length (which is how much of the stream has been initialized). In addition, each stream is given a separate file lock that is used to lock byte ranges and to allow concurrent access.

One component in Windows that uses multiple data streams is the Attachment Execution Service, which is invoked whenever the standard Windows API for saving internet-based attachments is used by applications such as Edge or Outlook. Depending on which *zone* the file was downloaded from (such as the My Computer zone, the Intranet zone, or the Untrusted zone), Windows Explorer might warn the user that the file came from a possibly untrusted location or even completely block access to the file. For example, Figure 11-24 shows the dialog box that’s displayed when executing Process Explorer after it was downloaded from the Sysinternals site. This type of data stream is called the \$Zone.Identifier and is colloquially referred to as the “Mark of the Web.”



Note If you clear the check box for Always Ask Before Opening This File, the zone identifier data stream will be removed from the file.

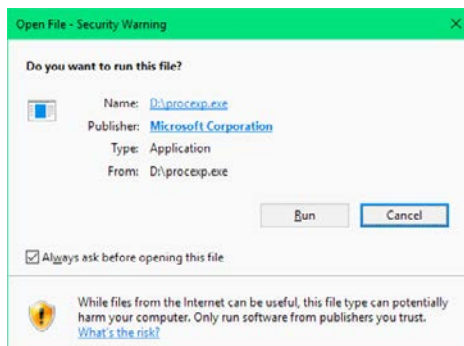

FIGURE 11-24 Security warning for files downloaded from the internet.

Other applications can use the multiple data stream feature as well. A backup utility, for example, might use an extra data stream to store backup-specific time stamps on files. Or an archival utility might implement hierarchical storage in which files that are older than a certain date or that haven't been accessed for a specified period of time are moved to offline storage. The utility could copy the file to offline storage, set the file's default data stream to 0, and add a data stream that specifies where the file is stored.

EXPERIMENT: Looking at streams

Most Windows applications aren't designed to work with alternate named streams, but both the **echo** and **more** commands are. Thus, a simple way to view streams in action is to create a named stream using **echo** and then display it using **more**. The following command sequence creates a file named `test` with a stream named `stream`:

```
c:\Test>echo Hello from a named stream! > test:stream
c:\Test>more < test:stream
Hello from a named stream!

c:\Test>
```

If you perform a directory listing, `Test`'s file size doesn't reflect the data stored in the alternate stream because NTFS returns the size of only the unnamed data stream for file query operations, including directory listings.

```
c:\Test>dir test
Volume in drive C is OS.
Volume Serial Number is F080-620F

Directory of c:\Test

12/07/2018  05:33 PM                0 test
                1 File(s)                0 bytes
                0 Dir(s)  18,083,577,856 bytes free

c:\Test>
```

You can determine what files and directories on your system have alternate data streams with the Streams utility from Sysinternals (see the following output) or by using the `/r` switch in the `dir` command.

```
c:\Test>streams test

streams v1.60 - Reveal NTFS alternate streams.
Copyright (C) 2005-2016 Mark Russinovich
Sysinternals - www.sysinternals.com

c:\Test\test:
    :stream:$DATA 29
```

Unicode-based names

Like Windows as a whole, NTFS supports 16-bit Unicode 1.0/UTF-16 characters to store names of files, directories, and volumes. Unicode allows each character in each of the world's major languages to be uniquely represented (Unicode can even represent emoji, or small drawings), which aids in moving data easily from one country to another. Unicode is an improvement over the traditional representation of international characters—using a double-byte coding scheme that stores some characters in 8 bits and others in 16 bits, a technique that requires loading various code pages to establish the available characters. Because Unicode has a unique representation for each character, it doesn't depend on which code page is loaded. Each directory and file name in a path can be as many as 255 characters long and can contain Unicode characters, embedded spaces, and multiple periods.

General indexing facility

The NTFS architecture is structured to allow indexing of any file attribute on a disk volume using a B-tree structure. (Creating indexes on arbitrary attributes is not exported to users.) This structure enables the file system to efficiently locate files that match certain criteria—for example, all the files in a particular directory. In contrast, the FAT file system indexes file names but doesn't sort them, making lookups in large directories slow.

Several NTFS features take advantage of general indexing, including consolidated security descriptors, in which the security descriptors of a volume's files and directories are stored in a single internal stream, have duplicates removed, and are indexed using an internal security identifier that NTFS defines. The use of indexing by these features is described in the section "NTFS on-disk structure" later in this chapter.

Dynamic bad-cluster remapping

Ordinarily, if a program tries to read data from a bad disk sector, the read operation fails and the data in the allocated cluster becomes inaccessible. If the disk is formatted as a fault-tolerant NTFS volume, however, the Windows volume manager—or Storage Spaces, depending on the component that provides data redundancy—dynamically retrieves a good copy of the data that was stored on the bad sector and then sends NTFS a warning that the sector is bad. NTFS will then allocate a new cluster, replacing the cluster in which the bad sector resides, and copies the data to the new cluster. It adds the bad cluster to the list of bad clusters on that volume (stored in the hidden metadata file \$BadClus) and no longer uses it. This data recovery and dynamic bad-cluster remapping is an especially useful feature for file servers and fault-tolerant systems or for any application that can't afford to lose data. If the volume manager or Storage Spaces is not used when a sector goes bad (such as early in the boot sequence), NTFS still replaces the cluster and doesn't reuse it, but it can't recover the data that was on the bad sector.

Hard links

A hard link allows multiple paths to refer to the same file. (Hard links are not supported on directories.) If you create a hard link named `C:\Documents\Spec.doc` that refers to the existing file `C:\Users\Administrator\Documents\Spec.doc`, the two paths link to the same on-disk file, and you can make changes to the file using either path. Processes can create hard links with the Windows `CreateHardLink` function.

NTFS implements hard links by keeping a reference count on the actual data, where each time a hard link is created for the file, an additional file name reference is made to the data. This means that if you have multiple hard links for a file, you can delete the original file name that referenced the data (`C:\Users\Administrator\Documents\Spec.doc` in our example), and the other hard links (`C:\Documents\Spec.doc`) will remain and point to the data. However, because hard links are on-disk local references to data (represented by a *file record number*), they can exist only within the same volume and can't span volumes or computers.

EXPERIMENT: Creating a hard link

There are two ways you can create a hard link: the `fsutil hardlink create` command or the `mklink` utility with the `/H` option. In this experiment we'll use `mklink` because we'll use this utility later to create a symbolic link as well. First, create a file called `test.txt` and add some text to it, as shown here.

```
C:\>echo Hello from a Hard Link > test.txt
```

Now create a hard link called `hard.txt` as shown here:

```
C:\>mklink hard.txt test.txt /H
Hardlink created for hard.txt <<====>> test.txt
```

If you list the directory's contents, you'll notice that the two files will be identical in every way, with the same creation date, permissions, and file size; only the file names differ.

```
c:\>dir *.txt
Volume in drive C is OS
Volume Serial Number is F080-620F

Directory of c:\

12/07/2018  05:46 PM                26 hard.txt
12/07/2018  05:46 PM                26 test.txt
             2 File(s)                52 bytes
             0 Dir(s) 15,150,333,952 bytes free
```

Symbolic (soft) links and junctions

In addition to hard links, NTFS supports another type of file-name aliasing called *symbolic links* or *soft links*. Unlike hard links, symbolic links are strings that are interpreted dynamically and can be relative or absolute paths that refer to locations on any storage device, including ones on a different local volume or even a share on a different system. This means that symbolic links don't actually increase the reference count of the original file, so deleting the original file will result in the loss of the data, and a symbolic link that points to a nonexisting file will be left behind. Finally, unlike hard links, symbolic links can point to directories, not just files, which gives them an added advantage.

For example, if the path `C:\Drivers` is a directory symbolic link that redirects to `%SystemRoot%\System32\Drivers`, an application reading `C:\Drivers\Ntfs.sys` actually reads `%SystemRoot%\System\Drivers\Ntfs.sys`. Directory symbolic links are a useful way to lift directories that are deep in a directory tree to a more convenient depth without disturbing the original tree's structure or contents. The example just cited lifts the `Drivers` directory to the volume's root directory, reducing the directory depth of `Ntfs.sys` from three levels to one when `Ntfs.sys` is accessed through the directory symbolic link. File symbolic links work much the same way—you can think of them as shortcuts, except they're actually implemented on the file system instead of being `.lnk` files managed by Windows Explorer. Just like hard links, symbolic links can be created with the `mklink` utility (without the `/H` option) or through the `CreateSymbolicLink` API.

Because certain legacy applications might not behave securely in the presence of symbolic links, especially across different machines, the creation of symbolic links requires the `SeCreateSymbolicLink` privilege, which is typically granted only to administrators. Starting with Windows 10, and only if Developer Mode is enabled, callers of `CreateSymbolicLink` API can additionally specify the `SYMBOLIC_LINK_FLAG_ALLOW_UNPRIVILEGED_CREATE` flag to overcome this limitation (this allows a standard user is still able to create symbolic links from the command prompt window). The file system also has a behavior option called `SymLinkEvaluation` that can be configured with the following command:

```
fsutil behavior set SymLinkEvaluation
```

By default, the Windows default symbolic link evaluation policy allows only local-to-local and local-to-remote symbolic links but not the opposite, as shown here:

```
D:\>fsutil behavior query SymLinkEvaluation
Local to local symbolic links are enabled
Local to remote symbolic links are enabled.
Remote to local symbolic links are disabled.
Remote to Remote symbolic links are disabled.
```

Symbolic links are implemented using an NTFS mechanism called *reparse points*. (Reparse points are discussed further in the section “Reparse points” later in this chapter.) A reparse point is a file or directory that has a block of data called *reparse data* associated with it. Reparse data is user-defined data about the file or directory, such as its state or location that can be read from the reparse point by the application that created the data, a file system filter driver, or the I/O manager. When NTFS encounters a reparse point during a file or directory lookup, it returns the `STATUS_REPARSE` status code, which signals file system filter drivers that are attached to the volume and the I/O manager to examine the reparse data. Each reparse point type has a unique *reparse tag*. The reparse tag allows the component responsible for interpreting the reparse point's reparse data to recognize the reparse point without having to check the reparse data. A reparse tag owner, either a file system filter driver or the I/O manager, can choose one of the following options when it recognizes reparse data:

- The reparse tag owner can manipulate the path name specified in the file I/O operation that crosses the reparse point and let the I/O operation reissue with the altered path name. Junctions (described shortly) take this approach to redirect a directory lookup, for example.
- The reparse tag owner can remove the reparse point from the file, alter the file in some way, and then reissue the file I/O operation.

There are no Windows functions for creating reparse points. Instead, processes must use the `FSCTL_SET_REPARSE_POINT` file system control code with the Windows `DeviceIoControl` function. A process can query a reparse point's contents with the `FSCTL_GET_REPARSE_POINT` file system control code. The `FILE_ATTRIBUTE_REPARSE_POINT` flag is set in a reparse point's file attributes, so applications can check for reparse points by using the Windows `GetFileAttributes` function.

Another type of reparse point that NTFS supports is the *junction* (also known as *Volume Mount point*). Junctions are a legacy NTFS concept and work almost identically to directory symbolic links, except they can only be local to a volume. There is no advantage to using a junction instead of a directory symbolic link, except that junctions are compatible with older versions of Windows, while directory symbolic links are not.

As seen in the previous section, modern versions of Windows now allow the creation of reparse points that can point to non-empty directories. The system behavior (which can be controlled from minifilters drivers) depends on the position of the reparse point in the target file's full path. The filter manager, NTFS, and ReFS file system drivers use the exposed `FsRtlIsNonEmptyDirectoryReparsePointAllowed` API to detect if a reparse point type is allowed on non-empty directories.

EXPERIMENT: Creating a symbolic link

This experiment shows you the main difference between a symbolic link and a hard link, even when dealing with files on the same volume. Create a symbolic link called `soft.txt` as shown here, pointing to the `test.txt` file created in the previous experiment:

```
C:\>mklink soft.txt test.txt
symbolic link created for soft.txt <<====>> test.txt
```

If you list the directory's contents, you'll notice that the symbolic link doesn't have a file size and is identified by the `<SYMLINK>` type. Furthermore, you'll note that the creation time is that of the symbolic link, not of the target file. The symbolic link can also have security permissions that are different from the permissions on the target file.

```
C:\>dir *.txt
Volume in drive C is OS
Volume Serial Number is 38D4-EA71

Directory of C:\

05/12/2012  11:55 PM                8 hard.txt
05/13/2012  12:28 AM    <SYMLINK>      soft.txt [test.txt]
05/12/2012  11:55 PM                8 test.txt
                3 File(s)                16 bytes
                0 Dir(s)  10,636,480,512 bytes free
```

Finally, if you delete the original `test.txt` file, you can verify that both the hard link and symbolic link still exist but that the symbolic link does not point to a valid file anymore, while the hard link references the file data.

Compression and sparse files

NTFS supports compression of file data. Because NTFS performs compression and decompression procedures transparently, applications don't have to be modified to take advantage of this feature. Directories can also be compressed, which means that any files subsequently created in the directory are compressed.

Applications compress and decompress files by passing *DeviceIoControl* the `FSCTL_SET_COMPRESSION` file system control code. They query the compression state of a file or directory with the `FSCTL_GET_COMPRESSION` file system control code. A file or directory that is compressed has the `FILE_ATTRIBUTE_COMPRESSED` flag set in its attributes, so applications can also determine a file or directory's compression state with *GetFileAttributes*.

A second type of compression is known as *sparse files*. If a file is marked as sparse, NTFS doesn't allocate space on a volume for portions of the file that an application designates as empty. NTFS returns 0-filled buffers when an application reads from empty areas of a sparse file. This type of compression can be useful for client/server applications that implement circular-buffer logging, in which the server records information to a file, and clients asynchronously read the information. Because the information that the server writes isn't needed after a client has read it, there's no need to store the information in the file. By making such a file sparse, the client can specify the portions of the file it reads as empty, freeing up space on the volume. The server can continue to append new information to the file without fear that the file will grow to consume all available space on the volume.

As with compressed files, NTFS manages sparse files transparently. Applications specify a file's sparseness state by passing the `FSCTL_SET_SPARSE` file system control code to *DeviceIoControl*. To set a range of a file to empty, applications use the `FSCTL_SET_ZERO_DATA` code, and they can ask NTFS for a description of what parts of a file are sparse by using the control code `FSCTL_QUERY_ALLOCATED_RANGES`. One application of sparse files is the NTFS *change journal*, described next.

Change logging

Many types of applications need to monitor volumes for file and directory changes. For example, an automatic backup program might perform an initial full backup and then incremental backups based on file changes. An obvious way for an application to monitor a volume for changes is for it to scan the volume, recording the state of files and directories, and on a subsequent scan detect differences. This process can adversely affect system performance, however, especially on computers with thousands or tens of thousands of files.

An alternate approach is for an application to register a directory notification by using the *FindFirstChangeNotification* or *ReadDirectoryChangesW* Windows function. As an input parameter, the application specifies the name of a directory it wants to monitor, and the function returns whenever the contents of the directory change. Although this approach is more efficient than volume scanning, it requires the application to be running at all times. Using these functions can also require an application to scan directories because *FindFirstChangeNotification* doesn't indicate what changed—just that something in the directory has changed. An application can pass a buffer to *ReadDirectoryChangesW* that the FSD

fills in with change records. If the buffer overflows, however, the application must be prepared to fall back on scanning the directory.

NTFS provides a third approach that overcomes the drawbacks of the first two: an application can configure the NTFS change journal facility by using the *DeviceloControl* function's *FSCTL_CREATE_USN_JOURNAL* file system control code (USN is update sequence number) to have NTFS record information about file and directory changes to an internal file called the *change journal*. A change journal is usually large enough to virtually guarantee that applications get a chance to process changes without missing any. Applications use the *FSCTL_QUERY_USN_JOURNAL* file system control code to read records from a change journal, and they can specify that the *DeviceloControl* function not complete until new records are available.

Per-user volume quotas

Systems administrators often need to track or limit user disk space usage on shared storage volumes, so NTFS includes quota-management support. NTFS quota-management support allows for per-user specification of quota enforcement, which is useful for usage tracking and tracking when a user reaches warning and limit thresholds. NTFS can be configured to log an event indicating the occurrence to the System event log if a user surpasses his warning limit. Similarly, if a user attempts to use more volume storage than her quota limit permits, NTFS can log an event to the System event log and fail the application file I/O that would have caused the quota violation with a “disk full” error code.

NTFS tracks a user's volume usage by relying on the fact that it tags files and directories with the security ID (SID) of the user who created them. (See Chapter 7, “Security,” in Part 1 for a definition of SIDs.) The logical sizes of files and directories a user owns count against the user's administrator-defined quota limit. Thus, a user can't circumvent his or her quota limit by creating an empty sparse file that is larger than the quota would allow and then fill the file with nonzero data. Similarly, whereas a 50 KB file might compress to 10 KB, the full 50 KB is used for quota accounting.

By default, volumes don't have quota tracking enabled. You need to use the **Quota** tab of a volume's **Properties** dialog box, shown in Figure 11-25, to enable quotas, to specify default warning and limit thresholds, and to configure the NTFS behavior that occurs when a user hits the warning or limit threshold. The Quota Entries tool, which you can launch from this dialog box, enables an administrator to specify different limits and behavior for each user. Applications that want to interact with NTFS quota management use COM quota interfaces, including *IDiskQuotaControl*, *IDiskQuotaUser*, and *IDiskQuotaEvents*.

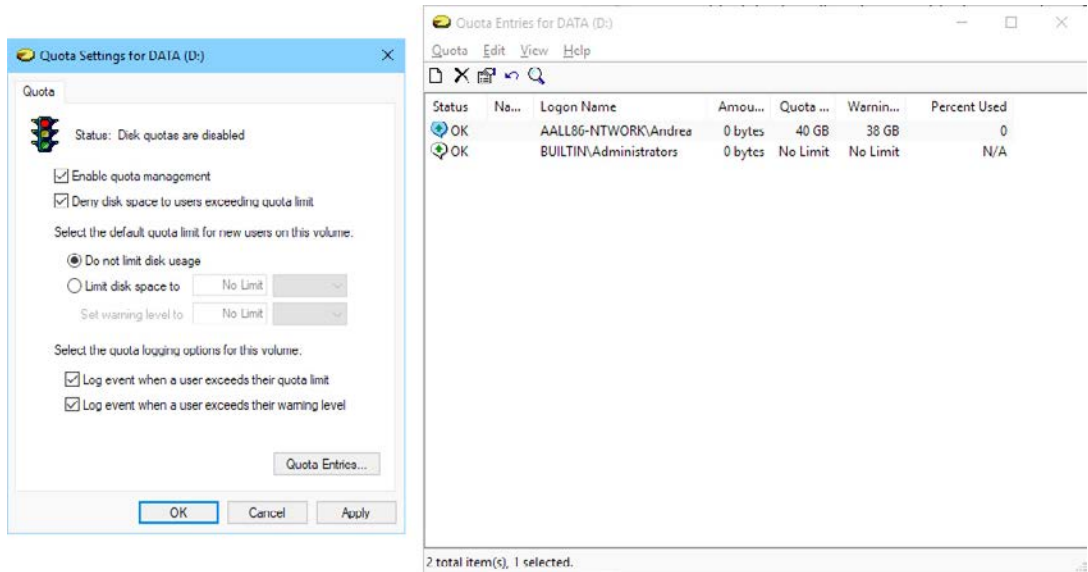

FIGURE 11-25 The Quota Settings dialog accessible from the volume's Properties window.

Link tracking

Shell shortcuts allow users to place files in their shell namespaces (on their desktops, for example) that link to files located in the file system namespace. The Windows Start menu uses shell shortcuts extensively. Similarly, object linking and embedding (OLE) links allow documents from one application to be transparently embedded in the documents of other applications. The products of the Microsoft Office suite, including PowerPoint, Excel, and Word, use OLE linking.

Although shell and OLE links provide an easy way to connect files with one another and with the shell namespace, they can be difficult to manage if a user moves the source of a shell or OLE link (a link source is the file or directory to which a link points). NTFS in Windows includes support for a service application called *distributed link-tracking*, which maintains the integrity of shell and OLE links when link targets move. Using the NTFS link-tracking support, if a link target located on an NTFS volume moves to any other NTFS volume within the originating volume's domain, the link-tracking service can transparently follow the movement and update the link to reflect the change.

NTFS link-tracking support is based on an optional file attribute known as an *object ID*. An application can assign an object ID to a file by using the *FSCTL_CREATE_OR_GET_OBJECT_ID* (which assigns an ID if one isn't already assigned) and *FSCTL_SET_OBJECT_ID* file system control codes. Object IDs are queried with the *FSCTL_CREATE_OR_GET_OBJECT_ID* and *FSCTL_GET_OBJECT_ID* file system control codes. The *FSCTL_DELETE_OBJECT_ID* file system control code lets applications delete object IDs from files.

Encryption

Corporate users often store sensitive information on their computers. Although data stored on company servers is usually safely protected with proper network security settings and physical access control, data stored on laptops can be exposed when a laptop is lost or stolen. NTFS file permissions don't offer protection because NTFS volumes can be fully accessed without regard to security by using NTFS file-reading software that doesn't require Windows to be running. Furthermore, NTFS file permissions are rendered useless when an alternate Windows installation is used to access files from an administrator account. Recall from Chapter 6 in Part 1 that the administrator account has the take-ownership and backup privileges, both of which allow it to access any secured object by overriding the object's security settings.

NTFS includes a facility called Encrypting File System (EFS), which users can use to encrypt sensitive data. The operation of EFS, as that of file compression, is completely transparent to applications, which means that file data is automatically decrypted when an application running in the account of a user authorized to view the data reads it and is automatically encrypted when an authorized application changes the data.



Note NTFS doesn't permit the encryption of files located in the system volume's root directory or in the Windows directory because many files in these locations are required during the boot process, and EFS isn't active during the boot process. BitLocker is a technology much better suited for environments in which this is a requirement because it supports full-volume encryption. As we will describe in the next paragraphs, BitLocker collaborates with NTFS for supporting file-encryption.

EFS relies on cryptographic services supplied by Windows in user mode, so it consists of both a kernel-mode component that tightly integrates with NTFS as well as user-mode DLLs that communicate with the Local Security Authority Subsystem (LSASS) and cryptographic DLLs.

Files that are encrypted can be accessed only by using the private key of an account's EFS private/public key pair, and private keys are locked using an account's password. Thus, EFS-encrypted files on lost or stolen laptops can't be accessed using any means (other than a brute-force cryptographic attack) without the password of an account that is authorized to view the data.

Applications can use the *EncryptFile* and *DecryptFile* Windows API functions to encrypt and decrypt files, and *FileEncryptionStatus* to retrieve a file or directory's EFS-related attributes, such as whether the file or directory is encrypted. A file or directory that is encrypted has the *FILE_ATTRIBUTE_ENCRYPTED* flag set in its attributes, so applications can also determine a file or directory's encryption state with *GetFileAttributes*.

POSIX-style delete semantics

The POSIX Subsystem has been deprecated and is no longer available in the Windows operating system. The Windows Subsystem for Linux (WSL) has replaced the original POSIX Subsystem. The NTFS file system driver has been updated to unify the differences between I/O operations supported in Windows and those supported in Linux. One of these differences is provided by the Linux *unlink* (or *rm*) command, which deletes a file or a folder. In Windows, an application can't delete a file that is in use by another application (which has an open handle to it); conversely, Linux usually supports this: other processes continue to work well with the original deleted file. To support WSL, the NTFS file system driver in Windows 10 supports a new operation: POSIX Delete.

The Win32 *DeleteFile* API implements standard file deletion. The target file is opened (a new handle is created), and then a disposition label is attached to the file through the *NtSetInformationFile* native API. The label just communicates to the NTFS file system driver that the file is going to be deleted. The file system driver checks whether the number of references to the FCB (File Control Block) is equal to 1, meaning that there is no other outstanding open handle to the file. If so, the file system driver marks the file as "deleted on close" and then returns. Only when the handle to the file is closed does the *IRP_MJ_CLEANUP* dispatch routine physically remove the file from the underlying medium.

A similar architecture is not compatible with the Linux *unlink* command. The WSL subsystem, when it needs to erase a file, employs POSIX-style deletion; it calls the *NtSetInformationFile* native API with the new *FileDispositionInformationEx* information class, specifying a flag (*FILE_DISPOSITION_POSIX_SEMANTICS*). The NTFS file system driver marks the file as POSIX deleted by inserting a flag in its Context Control Block (*CCB*, a data structure that represents the context of an open instance of an on-disk object). It then re-opens the file with a special internal routine and attaches the new handle (which we will call the *PosixDeleted* handle) to the SCB (stream control block). When the original handle is closed, the NTFS file system driver detects the presence of the *PosixDeleted* handle and queues a work item for closing it. When the work item completes, the Cleanup routine detects that the handle is marked as POSIX delete and physically moves the file in the "\\$Extend\\$Deleted" hidden directory. Other applications can still operate on the original file, which is no longer in the original namespace and will be deleted only when the last file handle is closed (the first delete request has marked the FCB as delete-on-close).

If for any unusual reason the system is not able to delete the target file (due to a dangling reference in a defective kernel driver or due to a sudden power interruption), the next time that the NTFS file system has the chance to mount the volume, it checks the \\$Extend\\$Deleted directory and deletes every file included in it by using standard file deletion routines.



Note Starting with the May 2019 Update (19H1), Windows 10 now uses POSIX delete as the default file deletion method. This means that the *DeleteFile* API uses the new behavior.

EXPERIMENT: Witnessing POSIX delete

In this experiment, you're going to witness a POSIX delete through the FsTool application, which is available in this book's downloadable resources. Make sure you're using a copy of Windows Server 2019 (RS5). Indeed, newer client releases of Windows implement POSIX deletions by default. Start by opening a command prompt window. Use the **/touch** FsTool command-line argument to generate a txt file that's exclusively used by the application:

```
D:\>FsTool.exe /touch d:\Test.txt
NTFS / ReFS Tool v0.1
Copyright (C) 2018 Andrea Allievi (AaL186)
```

```
Touching "d:\Test.txt" file... Success.
  The File handle is valid... Press Enter to write to the file.
```

When requested, instead of pressing the Enter key, open another command prompt window and try to open and delete the file:

```
D:\>type Test.txt
The process cannot access the file because it is being used by another process.
```

```
D:\>del Test.txt
```

```
D:\>dir Test.txt
Volume in drive D is DATA
Volume Serial Number is 62C1-9EB3
```

```
Directory of D:\

12/13/2018  12:34 AM                49 Test.txt
             1 File(s)                49 bytes
             0 Dir(s)  1,486,254,481,408 bytes free
```

As expected, you can't open the file while FsTool has exclusive access to it. When you try to delete the file, the system marks it for deletion, but it's not able to remove it from the file system namespace. If you try to delete the file again with File Explorer, you can witness the same behavior. When you press Enter in the first command prompt window and you exit the FsTool application, the file is actually deleted by the NTFS file system driver.

The next step is to use a POSIX deletion for getting rid of the file. You can do this by specifying the **/pdel** command-line argument to the FsTool application. In the first command prompt window, restart FsTool with the **/touch** command-line argument (the original file has been already marked for deletion, and you can't delete it again). Before pressing Enter, switch to the second window and execute the following command:

```
D:\>FsTool /pdel Test.txt
NTFS / ReFS Tool v0.1
Copyright (C) 2018 Andrea Allievi (AaL186)
```

```
Deleting "Test.txt" file (Posix semantics)... Success.
Press any key to exit...
```

```
D:\>dir Test.txt
Volume in drive D is DATA
Volume Serial Number is 62C1-9EB3
```

```
Directory of D:\
```

```
File Not Found
```

In this case the Test.txt file has been completely removed from the file system's namespace but is still valid. If you press Enter in the first command prompt window, FsTool is still able to write data to the file. This is because the file has been internally moved into the `\$Extend\Deleted` hidden system directory.

Defragmentation

Even though NTFS makes efforts to keep files contiguous when allocating blocks to extend a file, a volume's files can still become fragmented over time, especially if the file is extended multiple times or when there is limited free space. A file is fragmented if its data occupies discontinuous clusters. For example, Figure 11-26 shows a fragmented file consisting of five fragments. However, like most file systems (including versions of FAT on Windows), NTFS makes no special efforts to keep files contiguous (this is handled by the built-in defragmenter), other than to reserve a region of disk space known as the *master file table* (MFT) zone for the MFT. (NTFS lets other files allocate from the MFT zone when volume free space runs low.) Keeping an area free for the MFT can help it stay contiguous, but it, too, can become fragmented. (See the section "Master file table" later in this chapter for more information on MFTs.)

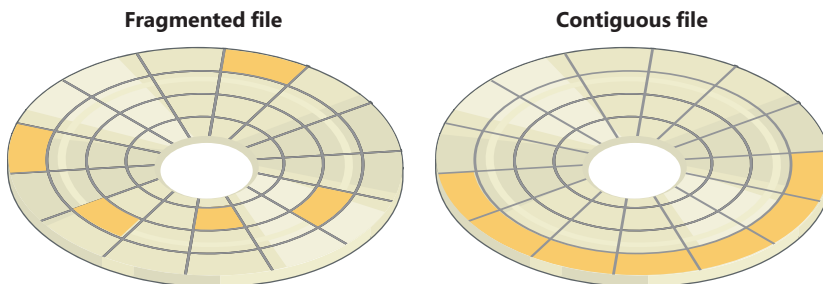

FIGURE 11-26 Fragmented and contiguous files.

To facilitate the development of third-party disk defragmentation tools, Windows includes a defragmentation API that such tools can use to move file data so that files occupy contiguous clusters. The API consists of file system controls that let applications obtain a map of a volume's free and in-use clusters (`FSCTL_GET_VOLUME_BITMAP`), obtain a map of a file's cluster usage (`FSCTL_GET_RETRIEVAL_POINTERS`), and move a file (`FSCTL_MOVE_FILE`).

Windows includes a built-in defragmentation tool that is accessible by using the Optimize Drives utility (%SystemRoot%\System32\Dfrgui.exe), shown in Figure 11-27, as well as a command-line interface, %SystemRoot%\System32\Defrag.exe, that you can run interactively or schedule, but that does not produce detailed reports or offer control—such as excluding files or directories—over the defragmentation process.

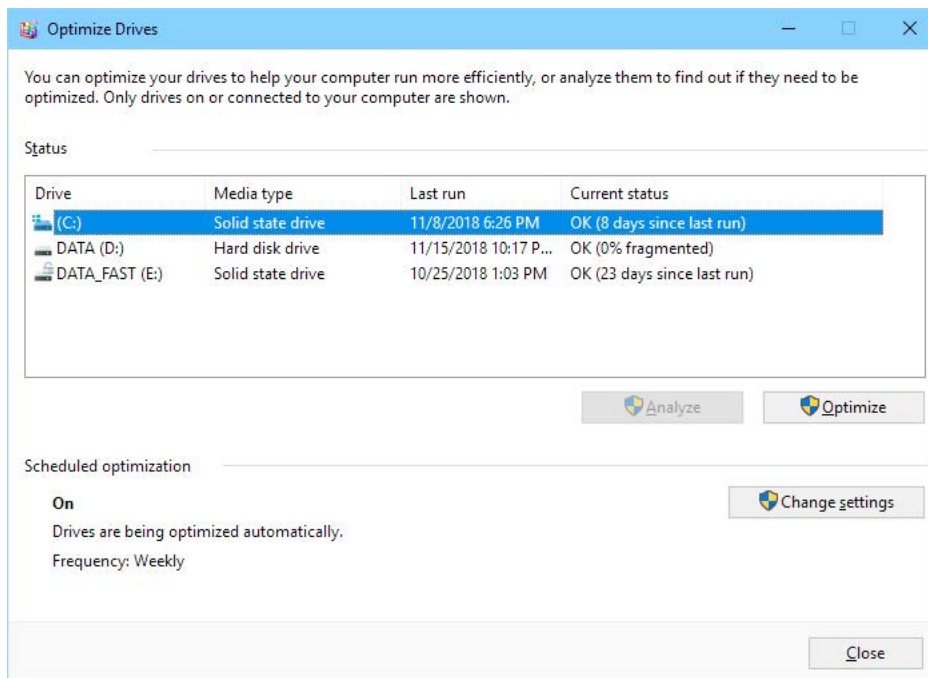

FIGURE 11-27 The Optimize Drives tool.

The only limitation imposed by the defragmentation implementation in NTFS is that paging files and NTFS log files can't be defragmented. The Optimize Drives tool is the evolution of the Disk Defragmenter, which was available in Windows 7. The tool has been updated to support tiered volumes, SMR disks, and SSD disks. The optimization engine is implemented in the Optimize Drive service (Defragvc.dll), which exposes the *IDefragEngine* COM interface used by both the graphical tool and the command-line interface.

For SSD disks, the tool also implements the retrim operation. To understand the retrim operation, a quick introduction of the architecture of a solid-state drive is needed. SSD disks store data in flash memory cells that are grouped into pages of 4 to 16 KB, grouped together into blocks of typically 128 to 512 pages. Flash memory cells can only be directly written to when they're empty. If they contain data, the contents must be erased before a write operation. An SSD write operation can be done on a single page but, due to hardware limitations, erase commands always affect entire blocks; consequently, writing data to empty pages on an SSD is very fast but slows down considerably once previously written pages need to be overwritten. (In this case, first the content of the entire block is stored in

cache, and then the entire block is erased from the SSD. The overwritten page is written to the cached block, and finally the entire updated block is written to the flash medium.) To overcome this problem, the NTFS File System Driver tries to send a *TRIM* command to the SSD controller every time it deletes the disk's clusters (which could partially or entirely belong to a file). In response to the *TRIM* command, the SSD, if possible, starts to asynchronously erase entire blocks. Noteworthy is that the SSD controller can't do anything in case the deleted area corresponds only to some pages of the block.

The retrim operation analyzes the SSD disk and starts to send a *TRIM* command to every cluster in the free space (in chunks of 1-MB size). There are different motivations behind this:

- *TRIM* commands are not always emitted. (The file system is not very strict on trims.)
- The NTFS File System emits *TRIM* commands on pages, but not on SSD blocks. The Disk Optimizer, with the retrim operation, searches fragmented blocks. For those blocks, it first moves valid data back to some temporary blocks, defragmenting the original ones and inserting even pages that belongs to other fragmented blocks; finally, it emits *TRIM* commands on the original cleaned blocks.



Note The way in which the Disk Optimizer emits *TRIM* commands on free space is somewhat tricky: Disk Optimizer allocates an empty sparse file and searches for a chunk (the size of which varies from 128 KB to 1 GB) of free space. It then calls the file system through the *FSCTL_MOVE_FILE* control code and moves data from the sparse file (which has a size of 1 GB but does not actually contain any valid data) into the empty space. The underlying file system actually erases the content of the one or more SSD blocks (sparse files with no valid data yield back chunks of zeroed data when read). This is the implementation of the *TRIM* command that the SSD firmware does.

For Tiered and SMR disks, the Optimize Drives tool supports two supplementary operations: Slabify (also known as Slab Consolidation) and Tier Optimization. Big files stored on tiered volumes can be composed of different Extents residing in different tiers. The Slab consolidation operation not only defragments the extent table (a phase called Consolidation) of a file, but it also moves the file content in congruent slabs (a slab is a unit of allocation of a thinly provisioned disk; see the “Storage Spaces” section later in this chapter for more information). The final goal of Slab Consolidation is to allow files to use a smaller number of slabs. Tier Optimization moves frequently accessed files (including files that have been explicitly pinned) from the capacity tier to the performance tier and, vice versa, moves less frequently accessed files from the performance tier to the capacity tier. To do so, the optimization engine consults the tiering engine, which provides file extents that should be moved to the capacity tier and those that should be moved to the performance tier, based on the Heat map for every file accessed by the user.



Note Tiered disks and the tiering engine are covered in detail in the following sections of the current chapter.

EXPERIMENT: Retrim an SSD volume

You can execute a Retrim on a fast SSD or NVMe volume by using the **defrag.exe /L** command, as in the following example:

```
D:\>defrag /L c:
Microsoft Drive Optimizer
Copyright (c) Microsoft Corp.

Invoking retrim on (C:)...

The operation completed successfully.

Post Defragmentation Report:

    Volume Information:
        Volume size           = 475.87 GB
        Free space            = 343.80 GB

    Retrim:
        Total space trimmed   = 341.05 GB
```

In the example, the volume size was 475.87 GB, with 343.80 GB of free space. Only 341 GB have been erased and trimmed. Obviously, if you execute the command on volumes backed by a classical HDD, you will get back an error. (The operation requested is not supported by the hardware backing the volume.)

Dynamic partitioning

The NTFS driver allows users to dynamically resize any partition, including the system partition, either shrinking or expanding it (if enough space is available). Expanding a partition is easy if enough space exists on the disk and the expansion is performed through the *FSCTL_EXPAND_VOLUME* file system control code. Shrinking a partition is a more complicated process because it requires moving any file system data that is currently in the area to be thrown away to the region that will still remain after the shrinking process (a mechanism similar to defragmentation). Shrinking is implemented by two components: the *shrinking engine* and the file system driver.

The shrinking engine is implemented in user mode. It communicates with NTFS to determine the maximum number of reclaimable bytes—that is, how much data can be moved from the region that will be resized into the region that will remain. The shrinking engine uses the standard defragmentation mechanism shown earlier, which doesn't support relocating page file fragments that are in use or any other files that have been marked as unmovable with the *FSCTL_MARK_HANDLE* file system control code (like the hibernation file). The master file table backup (\$MftMirr), the NTFS metadata transaction log (\$LogFile), and the volume label file (\$Volume) cannot be moved, which limits the minimum size of the shrunk volume and causes wasted space.

The file system driver shrinking code is responsible for ensuring that the volume remains in a consistent state throughout the shrinking process. To do so, it exposes an interface that uses three requests that describe the current operation, which are sent through the `FSCTL_SHRINK_VOLUME` control code:

- The `ShrinkPrepare` request, which must be issued before any other operation. This request takes the desired size of the new volume in sectors and is used so that the file system can block further allocations outside the new volume boundary. The `ShrinkPrepare` request doesn't verify whether the volume can actually be shrunk by the specified amount, but it does ensure that the amount is numerically valid and that there aren't any other shrinking operations ongoing. Note that after a prepare operation, the file handle to the volume becomes associated with the shrink request. If the file handle is closed, the operation is assumed to be aborted.
- The `ShrinkCommit` request, which the shrinking engine issues after a `ShrinkPrepare` request. In this state, the file system attempts the removal of the requested number of clusters in the most recent prepare request. (If multiple prepare requests have been sent with different sizes, the last one is the determining one.) The `ShrinkCommit` request assumes that the shrinking engine has completed and will fail if any allocated blocks remain in the area to be shrunk.
- The `ShrinkAbort` request, which can be issued by the shrinking engine or caused by events such as the closure of the file handle to the volume. This request undoes the `ShrinkCommit` operation by returning the partition to its original size and allows new allocations outside the shrunk region to occur again. However, defragmentation changes made by the shrinking engine remain.

If a system is rebooted during a shrinking operation, NTFS restores the file system to a consistent state via its metadata recovery mechanism, explained later in the chapter. Because the actual shrink operation isn't executed until all other operations have been completed, the volume retains its original size and only defragmentation operations that had already been flushed out to disk persist.

Finally, shrinking a volume has several effects on the volume shadow copy mechanism. Recall that the copy-on-write mechanism allows VSS to simply retain parts of the file that were actually modified while still linking to the original file data. For deleted files, this file data will not be associated with visible files but appears as free space instead—free space that will likely be located in the area that is about to be shrunk. The shrinking engine therefore communicates with VSS to engage it in the shrinking process. In summary, the VSS mechanism's job is to copy deleted file data into its differencing area and to increase the differencing area as required to accommodate additional data. This detail is important because it poses another constraint on the size to which even volumes with ample free space can shrink.

NTFS support for tiered volumes

Tiered volumes are composed of different types of storage devices and underlying media. Tiered volumes are usually created on the top of a single physical or virtual disk. Storage Spaces provides virtual disks that are composed of multiple physical disks, which can be of different types (and have different performance): fast NVMe disks, SSD, and Rotating Hard-Disk. A virtual disk of this type is called a *tiered disk*. (Storage Spaces uses the name *Storage Tiers*.) On the other hand, tiered volumes could be created on the top of physical SMR disks, which have a conventional "random-access" fast zone and a "strictly sequential" capacity area. All tiered volumes have the common characteristic that they are composed

by a “performance” tier, which supports fast random I/O, and a “capacity” tier, which may or may not support random I/O, is slower, and has a large capacity.



Note SMR disks, tiered volumes, and Storage Spaces will be discussed in more detail later in this chapter.

The NTFS File System driver supports tiered volumes in multiple ways:

- The volume is split in two zones, which correspond to the tiered disk areas (capacity and performance).
- The new *\$DSC* attribute (of type *\$LOGGED_UTILITY_STREAM*) specifies which tier the file should be stored in. NTFS exposes a new “pinning” interface, which allows a file to be locked in a particular tier (from here derives the term “pinning”) and prevents the file from being moved by the tiering engine.
- The Storage Tiers Management service has a central role in supporting tiered volumes. The NTFS file system driver records ETW “heat” events every time a file stream is read or written. The tiering engine consumes these events, accumulates them (in 1-MB chunks), and periodically records them in a JET database (once every hour). Every four hours, the tiering engine processes the Heat database and through a complex “heat aging” algorithm decides which file is considered recent (hot) and which is considered old (cold). The tiering engine moves the files between the performance and the capacity tiers based on the calculated Heat data.

Furthermore, the NTFS allocator has been modified to allocate file clusters based on the tier area that has been specified in the *\$DSC* attribute. The NTFS Allocator uses a specific algorithm to decide from which tier to allocate the volume’s clusters. The algorithm operates by performing checks in the following order:

1. If the file is the Volume USN Journal, always allocate from the Capacity tier.
2. MFT entries (File Records) and system metadata files are always allocated from the Performance tier.
3. If the file has been previously explicitly “pinned” (meaning that the file has the *\$DSC* attribute), allocate from the specified storage tier.
4. If the system runs a client edition of Windows, always prefer the Performance tier; otherwise, allocate from the Capacity tier.
5. If there is no space in the Performance tier, allocate from the Capacity tier.

An application can specify the desired storage tier for a file by using the *NtSetInformationFile* API with the *FileDesiredStorageClassInformation* information class. This operation is called *file pinning*, and, if executed on a handle of a new created file, the central allocator will allocate the new file content in the specified tier. Otherwise, if the file already exists and is located on the wrong tier, the tiering engine will move the file to the desired tier the next time it runs. (This operation is called *Tier optimization* and can be initiated by the Tiering Engine scheduled task or the SchedulerDefrag task.)



Note It's important to note here that the support for tiered volumes in NTFS, described here, is completely different from the support provided by the ReFS file system driver.

EXPERIMENT: Witnessing file pinning in tiered volumes

As we have described in the previous section, the NTFS allocator uses a specific algorithm to decide which tier to allocate from. In this experiment, you copy a big file into a tiered volume and understand what the implications of the File Pinning operation are. After the copy finishes, open an administrative PowerShell window by right-clicking on the Start menu icon and selecting Windows PowerShell (Admin) and use the **Get-FileStorageTier** command to get the tier information for the file:

```
PS E:\> Get-FileStorageTier -FilePath 'E:\Big_Image.iso' | FL FileSize,
DesiredStorageTierClass, FileSizeOnPerformanceTierClass, FileSizeOnCapacityTierClass,
PlacementStatus, State
```

```
FileSize                : 4556566528
DesiredStorageTierClass : Unknown
FileSizeOnPerformanceTierClass : 0
FileSizeOnCapacityTierClass : 4556566528
PlacementStatus         : Unknown
State                   : Unknown
```

The example shows that the `Big_Image.iso` file has been allocated from the Capacity Tier. (The example has been executed on a Windows Server system.) To confirm this, just copy the file from the tiered disk to a fast SSD volume. You should see a slow transfer speed (usually between 160 and 250 MB/s depending on the rotating disk speed):

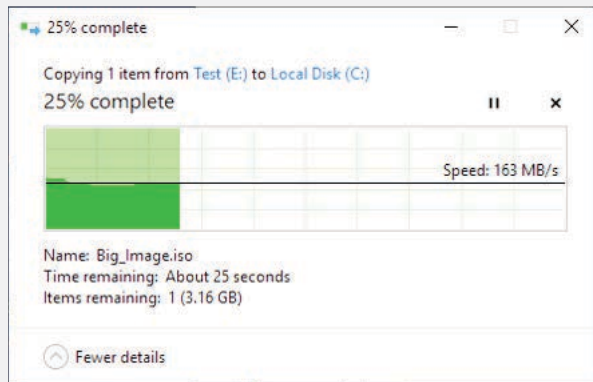

You can now execute the “pin” request through the **Set-FileStorageTier** command, like in the following example:

```
PS E:\> Get-StorageTier -MediaType SSD | FL FriendlyName, Size, FootprintOnPool, UniqueId
```

```
FriendlyName      : SSD
Size              : 128849018880
FootprintOnPool  : 128849018880
UniqueId         : {448abab8-f00b-42d6-b345-c8da68869020}
```

```
PS E:\> Set-FileStorageTier -FilePath 'E:\Big_Image.iso' -DesiredStorageTierFriendlyName 'SSD'
```

```
PS E:\> Get-FileStorageTier -FilePath 'E:\Big_Image.iso' | FL FileSize,
DesiredStorageTierClass, FileSizeOnPerformanceTierClass, FileSizeOnCapacityTierClass,
PlacementStatus, State
```

```
FileSize              : 4556566528
DesiredStorageTierClass : Performance
FileSizeOnPerformanceTierClass : 0
FileSizeOnCapacityTierClass : 4556566528
PlacementStatus      : Not on tier
State                : Pending
```

The example above shows that the file has been correctly pinned on the Performance tier, but its content is still stored in the Capacity tier. When the Tiering Engine scheduled task runs, it moves the file extents from the Capacity to the Performance tier. You can force a Tier Optimization by running the Drive optimizer through the **defrag.exe /g** built-in tool:

```
PS E:> defrag /g /h e:
Microsoft Drive Optimizer
Copyright (c) Microsoft Corp.
```

Invoking tier optimization on Test (E:)...

Pre-Optimization Report:

```
Volume Information:
  Volume size           = 2.22 TB
  Free space            = 1.64 TB
  Total fragmented space = 36%
  Largest free space size = 1.56 TB
```

Note: File fragments larger than 64MB are not included in the fragmentation statistics.

The operation completed successfully.

Post Defragmentation Report:

```
Volume Information:
  Volume size           = 2.22 TB
  Free space            = 1.64 TB
```

Storage Tier Optimization Report:

% I/Os Serviced from Perf Tier	Perf Tier Size Required
100%	28.51 GB *
95%	22.86 GB
...	
20%	2.44 GB
15%	1.58 GB
10%	873.80 MB
5%	361.28 MB

* Current size of the Performance tier: 474.98 GB
Percent of total I/Os serviced from the Performance tier: 99%

Size of files pinned to the Performance tier: 4.21 GB
Percent of total I/Os: 1%

Size of files pinned to the Capacity tier: 0 bytes
Percent of total I/Os: 0%

The Drive Optimizer has confirmed the “pinning” of the file. You can check again the “pinning” status by executing the *Get-FileStorageTier* command and by copying the file again to an SSD volume. This time the transfer rate should be much higher, because the file content is entirely located in the Performance tier.

```
PS E:\> Get-FileStorageTier -FilePath 'E:\Big_Image.iso' | FL FileSize, DesiredStorageTierClass,
FileSizeOnPerformanceTierClass, FileSizeOnCapacityTierClass, PlacementStatus, State
```

```
FileSize                : 4556566528
DesiredStorageTierClass : Performance
FileSizeOnPerformanceTierClass : 0
FileSizeOnCapacityTierClass : 4556566528
PlacementStatus         : Completely on tier
State                   : OK
```

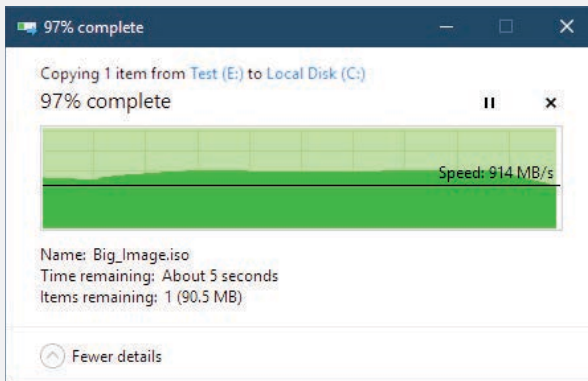

You could repeat the experiment in a client edition of Windows 10, by pinning the file in the Capacity tier (client editions of Windows 10 allocate file’s clusters from the Performance tier by default). The same “pinning” functionality has been implemented into the *FsTool* application available in this book’s downloadable resources, which can be used to copy a file directly into a preferred tier.

NTFS file system driver

As described in Chapter 6 in Part I, in the framework of the Windows I/O system, NTFS and other file systems are loadable device drivers that run in kernel mode. They are invoked indirectly by applications that use Windows or other I/O APIs. As Figure 11-28 shows, the Windows environment subsystems call Windows system services, which in turn locate the appropriate loaded drivers and call them. (For a description of system service dispatching, see the section “System service dispatching” in Chapter 8.)

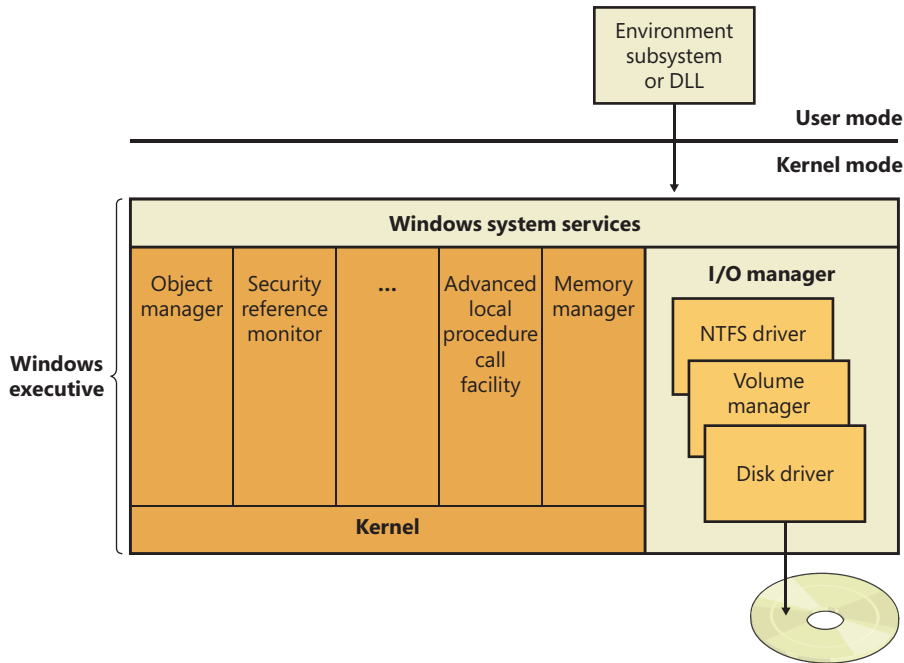

FIGURE 11-28 Components of the Windows I/O system.

The layered drivers pass I/O requests to one another by calling the Windows executive’s I/O manager. Relying on the I/O manager as an intermediary allows each driver to maintain independence so that it can be loaded or unloaded without affecting other drivers. In addition, the NTFS driver interacts with the three other Windows executive components, shown in the left side of Figure 11-29, which are closely related to file systems.

The log file service (LFS) is the part of NTFS that provides services for maintaining a log of disk writes. The log file that LFS writes is used to recover an NTFS-formatted volume in the case of a system failure. (See the section “Log file service” later in this chapter.)

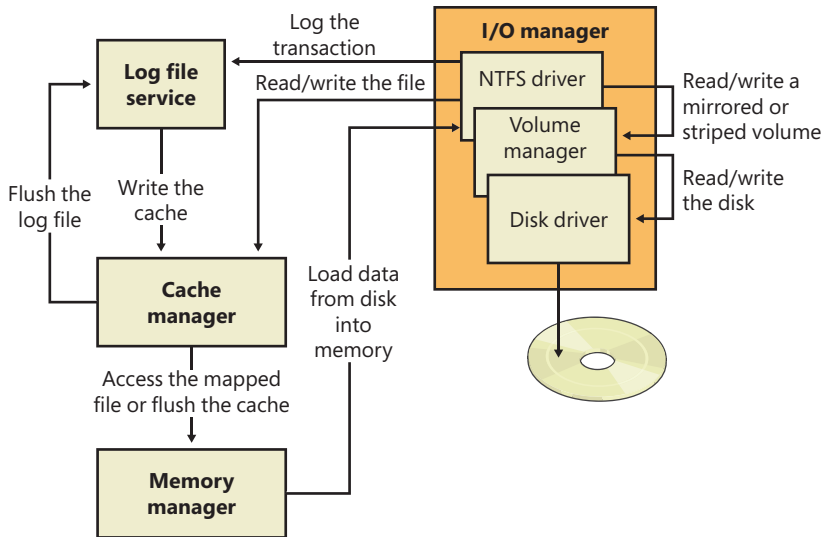

FIGURE 11-29 NTFS and related components.

As we have already described, the cache manager is the component of the Windows executive that provides systemwide caching services for NTFS and other file system drivers, including network file system drivers (servers and redirectors). All file systems implemented for Windows access cached files by mapping them into system address space and then accessing the virtual memory. The cache manager provides a specialized file system interface to the Windows memory manager for this purpose. When a program tries to access a part of a file that isn't loaded into the cache (a *cache miss*), the memory manager calls NTFS to access the disk driver and obtain the file contents from disk. The cache manager optimizes disk I/O by using its lazy writer threads to call the memory manager to flush cache contents to disk as a background activity (asynchronous disk writing).

NTFS, like other file systems, participates in the Windows object model by implementing files as objects. This implementation allows files to be shared and protected by the object manager, the component of Windows that manages all executive-level objects. (The object manager is described in the section "Object manager" in Chapter 8.)

An application creates and accesses files just as it does other Windows objects: by means of object handles. By the time an I/O request reaches NTFS, the Windows object manager and security system have already verified that the calling process has the authority to access the file object in the way it is attempting to. The security system has compared the caller's access token to the entries in the access control list for the file object. (See Chapter 7 in Part 1 for more information about access control lists.) The I/O manager has also transformed the file handle into a pointer to a file object. NTFS uses the information in the file object to access the file on disk.

Figure 11-30 shows the data structures that link a file handle to the file system's on-disk structure.

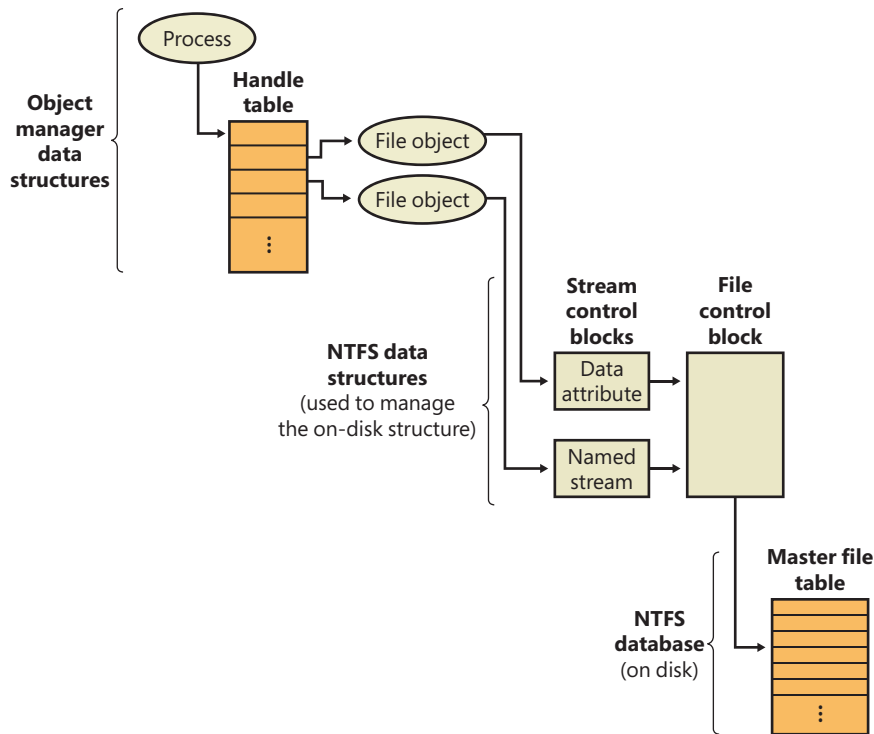

FIGURE 11-30 NTFS data structures.

NTFS follows several pointers to get from the file object to the location of the file on disk. As Figure 11-30 shows, a file object, which represents a single call to the open-file system service, points to a *stream control block* (SCB) for the file attribute that the caller is trying to read or write. In Figure 11-30, a process has opened both the unnamed data attribute and a named stream (alternate data attribute) for the file. The SCBs represent individual file attributes and contain information about how to find specific attributes within a file. All the SCBs for a file point to a common data structure called a *file control block* (FCB). The FCB contains a pointer (actually, an index into the MFT, as explained in the section “File record numbers” later in this chapter) to the file’s record in the disk-based master file table (MFT), which is described in detail in the following section.

NTFS on-disk structure

This section describes the on-disk structure of an NTFS volume, including how disk space is divided and organized into clusters, how files are organized into directories, how the actual file data and attribute information is stored on disk, and finally, how NTFS data compression works.

Volumes

The structure of NTFS begins with a volume. A *volume* corresponds to a logical partition on a disk, and it's created when you format a disk or part of a disk for NTFS. You can also create a RAID virtual disk that spans multiple physical disks by using Storage Spaces, which is accessible through the Manage Storage Spaces control panel snap-in, or by using Storage Spaces commands available from the Windows PowerShell (like the `New-StoragePool` command, used to create a new storage pool. A comprehensive list of PowerShell commands for Storage Spaces is available at the following link: <https://docs.microsoft.com/en-us/powershell/module/storagespaces/>)

A disk can have one volume or several. NTFS handles each volume independently of the others. Three sample disk configurations for a 2-TB hard disk are illustrated in Figure 11-31.

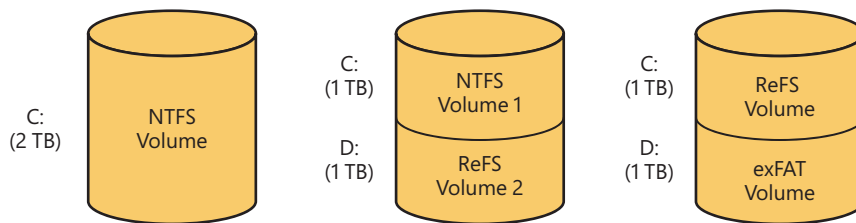

FIGURE 11-31 Sample disk configurations.

A volume consists of a series of files plus any additional unallocated space remaining on the disk partition. In all FAT file systems, a volume also contains areas specially formatted for use by the file system. An NTFS or ReFS volume, however, stores all file system data, such as bitmaps and directories, and even the system bootstrap, as ordinary files.



Note The on-disk format of NTFS volumes on Windows 10 and Windows Server 2019 is version 3.1, the same as it has been since Windows XP and Windows Server 2003. The version number of a volume is stored in its \$Volume metadata file.

Clusters

The cluster size on an NTFS volume, or the *cluster factor*, is established when a user formats the volume with either the `format` command or the Disk Management MMC snap-in. The default cluster factor varies with the size of the volume, but it is an integral number of physical sectors, always a power of 2 (1 sector, 2 sectors, 4 sectors, 8 sectors, and so on). The cluster factor is expressed as the number of bytes in the cluster, such as 512 bytes, 1 KB, 2 KB, and so on.

Internally, NTFS refers only to clusters. (However, NTFS forms low-level volume I/O operations such that clusters are sector-aligned and have a length that is a multiple of the sector size.) NTFS uses the cluster as its unit of allocation to maintain its independence from physical sector sizes. This independence allows NTFS to efficiently support very large disks by using a larger cluster factor or to support newer disks that have a sector size other than 512 bytes. On a larger volume, use of a larger cluster factor can reduce fragmentation and speed allocation, at the cost of wasted disk space. (If the cluster size is 64 KB, and a file is only 16 KB, then 48 KB are wasted.) Both the *format* command available from the command prompt and the Format menu option under the All Tasks option on the Action menu in the Disk Management MMC snap-in choose a default cluster factor based on the volume size, but you can override this size.

NTFS refers to physical locations on a disk by means of *logical cluster numbers* (LCNs). LCNs are simply the numbering of all clusters from the beginning of the volume to the end. To convert an LCN to a physical disk address, NTFS multiplies the LCN by the cluster factor to get the physical byte offset on the volume, as the disk driver interface requires. NTFS refers to the data within a file by means of *virtual cluster numbers* (VCNs). VCNs number the clusters belonging to a particular file from 0 through *m*. VCNs aren't necessarily physically contiguous, however; they can be mapped to any number of LCNs on the volume.

Master file table

In NTFS, all data stored on a volume is contained in files, including the data structures used to locate and retrieve files, the bootstrap data, and the bitmap that records the allocation state of the entire volume (the NTFS metadata). Storing everything in files allows the file system to easily locate and maintain the data, and each separate file can be protected by a security descriptor. In addition, if a particular part of the disk goes bad, NTFS can relocate the metadata files to prevent the disk from becoming inaccessible.

The MFT is the heart of the NTFS volume structure. The MFT is implemented as an array of file records. The size of each file record can be 1 KB or 4 KB, as defined at volume-format time, and depends on the type of the underlying physical medium: new physical disks that have 4 KB native sectors size and tiered disks generally use 4 KB file records, while older disks that have 512 bytes sectors size use 1 KB file records. The size of each MFT entry does not depend on the clusters size and can be overridden at volume-format time through the **Format /I** command. (The structure of a file record is described in the "File records" section later in this chapter.) Logically, the MFT contains one record for each file on the volume, including a record for the MFT itself. In addition to the MFT, each NTFS volume includes a set of metadata files containing the information that is used to implement the file system structure. Each of these NTFS metadata files has a name that begins with a dollar sign (\$) and is hidden. For example, the file name of the MFT is \$MFT. The rest of the files on an NTFS volume are normal user files and directories, as shown in Figure 11-32.

Usually, each MFT record corresponds to a different file. If a file has a large number of attributes or becomes highly fragmented, however, more than one record might be needed for a single file. In such cases, the first MFT record, which stores the locations of the others, is called the *base file record*.

0	\$MFT - MFT
1	\$MFTMirr - MFT mirror
2	\$LogFile - Log file
3	\$Volume - Volume file
4	\$AttrDef - Attribute definition table
5	\ - Root directory
6	\$BitMap - Volume cluster allocation file
7	\$Boot - Boot sector
8	\$BadClus - Bad-cluster file
9	\$Secure - Security settings file
10	\$UpCase - Uppercase character mapping
11	\$Extend - Extended metadata directory
12	Unused
13	Unused
14	Unused
15	Unused
16	Unused
17	Unused
18	Unused
19	Unused
20	Unused
21	Unused
22	Unused
23	Unused
24	\$Extend\ \$Quota - Quota information
25	\$Extend\ \$ObjId - Distributed link tracking information
26	\$Extend\ \$Reparse - Back references to reparse points
27	\$Extend\ \$RmMetadata - RM metadata directory
28	\$Extend\ \$RmMetadata\ \$Repair - RM repair information
29	\$Extend\ \$Deleted - POSIX deleted files
30	\$Extend\ \$RmMetadata\ \$TxfLog - TxF log directory
31	\$Extend\ \$RmMetadata\ \$Txf - TxF metadata directory
32	\$Extend\ \$RmMetadata\ \$TxfLog\ \$Tops - TOPS file
33	\$Extend\ \$RmMetadata\ \$TxfLog\ \$TxfLog.blf - TxF BLF
34	\$TxfLogContainer00000000000000000001
35	\$TxfLogContainer00000000000000000002

Reserved for NTFS metadata files

FIGURE 11-32 File records for NTFS metadata files in the MFT.

When it first accesses a volume, NTFS must *mount* it—that is, read metadata from the disk and construct internal data structures so that it can process application file system accesses. To mount the volume, NTFS looks in the volume boot record (VBR) (located at LCN 0), which contains a data structure called the boot parameter block (BPB), to find the physical disk address of the MFT. The MFT’s file record is the first entry in the table; the second file record points to a file located in the middle of the disk called the *MFT mirror* (file name \$MFTMirr) that contains a copy of the first four rows of the MFT. This partial copy of the MFT is used to locate metadata files if part of the MFT file can’t be read for some reason.

Once NTFS finds the file record for the MFT, it obtains the VCN-to-LCN mapping information in the file record’s data attribute and stores it into memory. Each run (runs are explained later in this chapter in the section “Resident and nonresident attributes”) has a VCN-to-LCN mapping and a run length because that’s all the information necessary to locate the LCN for any VCN. This mapping information

tells NTFS where the runs containing the MFT are located on the disk. NTFS then processes the MFT records for several more metadata files and opens the files. Next, NTFS performs its file system recovery operation (described in the section “Recovery” later in this chapter), and finally, it opens its remaining metadata files. The volume is now ready for user access.



Note For the sake of clarity, the text and diagrams in this chapter depict a run as including a VCN, an LCN, and a run length. NTFS actually compresses this information on disk into an LCN/next-VCN pair. Given a starting VCN, NTFS can determine the length of a run by subtracting the starting VCN from the next VCN.

As the system runs, NTFS writes to another important metadata file, the *log file* (file name \$LogFile). NTFS uses the log file to record all operations that affect the NTFS volume structure, including file creation or any commands, such as *copy*, that alter the directory structure. The log file is used to recover an NTFS volume after a system failure and is also described in the “Recovery” section.

Another entry in the MFT is reserved for the *root directory* (also known as \; for example, C:\). Its file record contains an index of the files and directories stored in the root of the NTFS directory structure. When NTFS is first asked to open a file, it begins its search for the file in the root directory’s file record. After opening a file, NTFS stores the file’s MFT record number so that it can directly access the file’s MFT record when it reads and writes the file later.

NTFS records the allocation state of the volume in the *bitmap file* (file name \$Bitmap). The data attribute for the bitmap file contains a bitmap, each of whose bits represents a cluster on the volume, identifying whether the cluster is free or has been allocated to a file.

The *security file* (file name \$Secure) stores the volume-wide security descriptor database. NTFS files and directories have individually settable security descriptors, but to conserve space, NTFS stores the settings in a common file, which allows files and directories that have the same security settings to reference the same security descriptor. In most environments, entire directory trees have the same security settings, so this optimization provides a significant saving of disk space.

Another system file, the *boot file* (file name \$Boot), stores the Windows bootstrap code if the volume is a system volume. On nonsystem volumes, there is code that displays an error message on the screen if an attempt is made to boot from that volume. For the system to boot, the bootstrap code must be located at a specific disk address so that the Boot Manager can find it. During formatting, the *format* command defines this area as a file by creating a file record for it. All files are in the MFT, and all clusters are either free or allocated to a file—there are no hidden files or clusters in NTFS, although some files (metadata) are not visible to users. The boot file as well as NTFS metadata files can be individually protected by means of the security descriptors that are applied to all Windows objects. Using this “everything on the disk is a file” model also means that the bootstrap can be modified by normal file I/O, although the boot file is protected from editing.

NTFS also maintains a *bad-cluster file* (file name \$BadClus) for recording any bad spots on the disk volume and a file known as the *volume file* (file name \$Volume), which contains the volume name, the

version of NTFS for which the volume is formatted, and a number of flag bits that indicate the state and health of the volume, such as a bit that indicates that the volume is corrupt and must be repaired by the Chkdsk utility. (The Chkdsk utility is covered in more detail later in the chapter.) The *uppercase file* (file name \$UpCase) includes a translation table between lowercase and uppercase characters. NTFS maintains a file containing an *attribute definition table* (file name \$AttrDef) that defines the attribute types supported on the volume and indicates whether they can be indexed, recovered during a system recovery operation, and so on.



Note Figure 11-32 shows the Master File Table of a NTFS volume and indicates the specific entries in which the metadata files are located. It is worth mentioning that file records at position less than 16 are guaranteed to be fixed. Metadata files located at entries greater than 16 are subject to the order in which NTFS creates them. Indeed, the format tool doesn't create any metadata file above position 16; this is the duty of the NTFS file system driver while mounting the volume for the first time (after the formatting has been completed). The order of the metadata files generated by the file system driver is not guaranteed.

NTFS stores several metadata files in the *extensions* (directory name \$Extend) metadata directory, including the *object identifier file* (file name \$ObjId), the *quota file* (file name \$Quota), the *change journal file* (file name \$UsnJrnl), the *reparse point file* (file name \$Reparse), the *Posix delete* support directory (\$Deleted), and the *default resource manager directory* (directory name \$RmMetadata). These files store information related to extended features of NTFS. The object identifier file stores file object IDs, the quota file stores quota limit and behavior information on volumes that have quotas enabled, the change journal file records file and directory changes, and the reparse point file stores information about which files and directories on the volume include reparse point data.

The Posix Delete directory (\$Deleted) contains files, which are invisible to the user, that have been deleted using the new Posix semantic. Files deleted using the Posix semantic will be moved in this directory when the application that has originally requested the file deletion closes the file handle. Other applications that may still have a valid reference to the file continue to run while the file's name is deleted from the namespace. Detailed information about the Posix deletion has been provided in the previous section.

The default resource manager directory contains directories related to transactional NTFS (TxF) support, including the *transaction log directory* (directory name \$TxfLog), the *transaction isolation directory* (directory name \$Txf), and the *transaction repair directory* (file name \$Repair). The transaction log directory contains the *TxF base log file* (file name \$TxfLog.blf) and any number of log container files, depending on the size of the transaction log, but it always contains at least two: one for the Kernel Transaction Manager (KTM) log stream (file name \$TxfLogContainer00000000000000000001), and one for the TxF log stream (file name \$TxfLogContainer00000000000000000002). The transaction log directory also contains the *TxF old page stream* (file name \$Tops), which we'll describe later.

EXPERIMENT: Viewing NTFS information

You can use the built-in Fsutil.exe command-line program to view information about an NTFS volume, including the placement and size of the MFT and MFT zone:

```
d:\>fsutil fsinfo ntfsinfo d:
NTFS Volume Serial Number :      0x48323940323933f2
NTFS Version      :              3.1
LFS Version       :              2.0
Number Sectors   :              0x000000011c5f6fff
Total Clusters   :              0x00000000238bedff
Free Clusters    :              0x000000001a6e5925
Total Reserved   :              0x000000000000011cd
Bytes Per Sector  :              512
Bytes Per Physical Sector :      4096
Bytes Per Cluster :              4096
Bytes Per FileRecord Segment :   4096
Clusters Per FileRecord Segment : 1
Mft Valid Data Length :          0x0000000064650000
Mft Start Lcn    :              0x00000000000c0000
Mft2 Start Lcn   :              0x0000000000000002
Mft Zone Start   :              0x000000000069f76e0
Mft Zone End     :              0x000000000069f7700
Max Device Trim Extent Count :   4294967295
Max Device Trim Byte Count :     0x10000000
Max Volume Trim Extent Count :    62
Max Volume Trim Byte Count :     0x10000000
Resource Manager Identifier :     81E83020-E6FB-11E8-B862-D89EF33A38A7
```

In this example, the D: volume uses 4 KB file records (MFT entries), on a 4 KB native sector size disk (which emulates old 512-byte sectors) and uses 4 KB clusters.

File record numbers

A file on an NTFS volume is identified by a 64-bit value called a *file record number*, which consists of a file number and a sequence number. The file number corresponds to the position of the file's file record in the MFT minus 1 (or to the position of the base file record minus 1 if the file has more than one file record). The sequence number, which is incremented each time an MFT file record position is reused, enables NTFS to perform internal consistency checks. A file record number is illustrated in Figure 11-33.

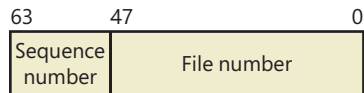

FIGURE 11-33 File record number.

File records

Instead of viewing a file as just a repository for textual or binary data, NTFS stores files as a collection of attribute/value pairs, one of which is the data it contains (called the *unnamed data attribute*). Other attributes that compose a file include the file name, time stamp information, and possibly additional named data attributes. Figure 11-34 illustrates an MFT record for a small file.

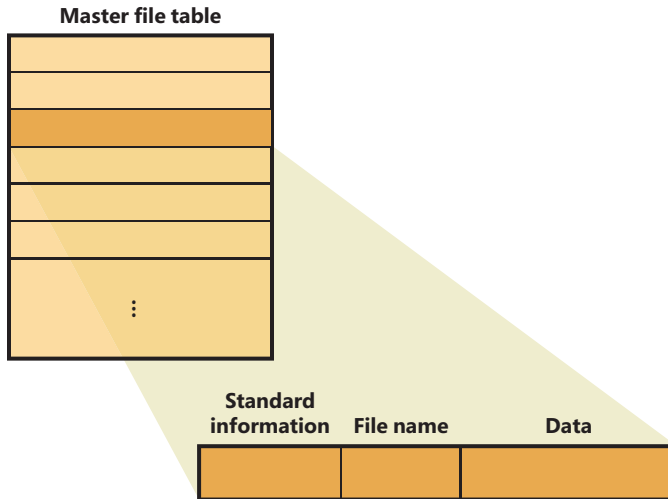

FIGURE 11-34 MFT record for a small file.

Each file attribute is stored as a separate stream of bytes within a file. Strictly speaking, NTFS doesn't read and write files; it reads and writes attribute streams. NTFS supplies these attribute operations: create, delete, read (byte range), and write (byte range). The read and write services normally operate on the file's unnamed data attribute. However, a caller can specify a different data attribute by using the named data stream syntax.

Table 11-6 lists the attributes for files on an NTFS volume. (Not all attributes are present for every file.) Each attribute in the NTFS file system can be unnamed or can have a name. An example of a named attribute is the `$LOGGED_UTILITY_STREAM`, which is used for various purposes by different NTFS components. Table 11-7 lists the possible `$LOGGED_UTILITY_STREAM` attribute's names and their respective purposes.

TABLE 11-6 Attributes for NTFS files

Attribute	Attribute Type Name	Resident?	Description
Volume information	\$VOLUME_INFORMATION, \$VOLUME_NAME	Always, Always	These attributes are present only in the \$Volume metadata file. They store volume version and label information.
Standard information	\$STANDARD_INFORMATION	Always	File attributes such as read-only, archive, and so on; time stamps, including when the file was created or last modified.
File name	\$FILE_NAME	Maybe	The file's name in Unicode 1.0 characters. A file can have multiple file name attributes, as it does when a hard link to a file exists or when a file with a long name has an automatically generated short name for access by MS-DOS and 16-bit Windows applications.
Security descriptor	\$SECURITY_DESCRIPTOR	Maybe	This attribute is present for backward compatibility with previous versions of NTFS and is rarely used in the current version of NTFS (3.1). NTFS stores almost all security descriptors in the \$Secure metadata file, sharing descriptors among files and directories that have the same settings. Previous versions of NTFS stored private security descriptor information with each file and directory. Some files still include a \$SECURITY_DESCRIPTOR attribute, such as \$Boot.
Data	\$DATA	Maybe	The contents of the file. In NTFS, a file has one default unnamed data attribute and can have additional named data attributes—that is, a file can have multiple data streams. A directory has no default data attribute but can have optional named data attributes. Named data streams can be used even for particular system purposes. For example, the Storage Reserve Area Table (SRAT) stream (\$SRAT) is used by the Storage Service for creating Space reservations on a volume. This attribute is applied only on the \$Bitmap metadata file. Storage Reserves are described later in this chapter.
Index root, index allocation	\$INDEX_ROOT, \$INDEX_ALLOCATION,	Always, Never	Three attributes used to implement B-tree data structures used by directories, security, quota, and other metadata files.
Attribute list	\$ATTRIBUTE_LIST	Maybe	A list of the attributes that make up the file and the file record number of the MFT entry where each attribute is located. This attribute is present when a file requires more than one MFT file record.
Index Bitmap	\$BITMAP	Maybe	This attribute is used for different purposes: for nonresident directories (where an \$INDEX_ALLOCATION always exists), the bitmap records which 4 KB-sized index blocks are already in use by the B-tree, and which are free for future use as B-tree grows; In the MFT there is an unnamed "\$Bitmap" attribute that tracks which MFT segments are in use, and which are free for future use by new files or by existing files that require more space.

Attribute	Attribute Type Name	Resident?	Description
Object ID	\$OBJECT_ID	Always	A 16-byte identifier (GUID) for a file or directory. The link-tracking service assigns object IDs to shell shortcut and OLE link source files. NTFS provides APIs so that files and directories can be opened with their object ID rather than their file name.
Reparse information	\$REPARSE_POINT	Maybe	This attribute stores a file's reparse point data. NTFS junctions and mount points include this attribute.
Extended attributes	\$EA, \$EA_INFORMATION	Maybe, Always	Extended attributes are name/value pairs and aren't normally used but are provided for backward compatibility with OS/2 applications.
Logged utility stream	\$LOGGED_UTILITY_STREAM	Maybe	This attribute type can be used for various purposes by different NTFS components. See Table 11-7 for more details.

TABLE 11-7 \$LOGGED_UTILITY_STREAM attribute

Attribute	Attribute Type Name	Resident?	Description
Encrypted File Stream	\$EFS	Maybe	EFS stores data in this attribute that's used to manage a file's encryption, such as the encrypted version of the key needed to decrypt the file and a list of users who are authorized to access the file.
Online encryption backup	\$EfsBackup	Maybe	The attribute is used by the EFS Online encryption to store chunks of the original encrypted data stream.
Transactional NTFSData	\$TXF_DATA	Maybe	When a file or directory becomes part of a transaction, TxF also stores transaction data in the \$TXF_DATA attribute, such as the file's unique transaction ID.
Desired Storage Class	\$DSC	Resident	The desired storage class is used for "pinning" a file to a preferred storage tier. See the "NTFS support for tiered volumes" section for more details.

Table 11-6 shows attribute names; however, attributes actually correspond to numeric type codes, which NTFS uses to order the attributes within a file record. The file attributes in an MFT record are ordered by these type codes (numerically in ascending order), with some attribute types appearing more than once—if a file has multiple data attributes, for example, or multiple file names. All possible attribute types (and their names) are listed in the \$AttrDef metadata file.

Each attribute in a file record is identified with its attribute type code and has a value and an optional name. An attribute's value is the byte stream composing the attribute. For example, the value of the \$FILE_NAME attribute is the file's name; the value of the \$DATA attribute is whatever bytes the user stored in the file.

Most attributes never have names, although the index-related attributes and the \$DATA attribute often do. Names distinguish between multiple attributes of the same type that a file can include. For example, a file that has a named data stream has two \$DATA attributes: an unnamed \$DATA attribute storing the default unnamed data stream, and a named \$DATA attribute having the name of the alternate stream and storing the named stream's data.

File names

Both NTFS and FAT allow each file name in a path to be as many as 255 characters long. File names can contain Unicode characters as well as multiple periods and embedded spaces. However, the FAT file system supplied with MS-DOS is limited to 8 (non-Unicode) characters for its file names, followed by a period and a 3-character extension. Figure 11-35 provides a visual representation of the different file namespaces Windows supports and shows how they intersect.

Windows Subsystem for Linux (WSL) requires the biggest namespace of all the application execution environments that Windows supports, and therefore the NTFS namespace is equivalent to the WSL namespace. WSL can create names that aren't visible to Windows and MS-DOS applications, including names with trailing periods and trailing spaces. Ordinarily, creating a file using the large POSIX namespace isn't a problem because you would do that only if you intended WSL applications to use that file.

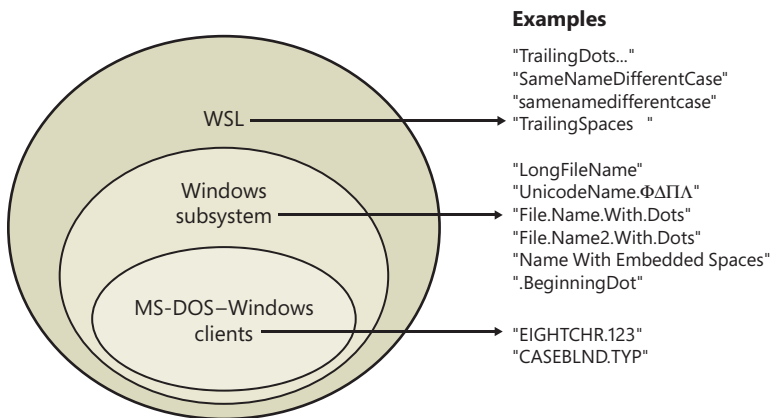

FIGURE 11-35 Windows file namespaces.

The relationship between 32-bit Windows applications and MS-DOS and 16-bit Windows applications is a much closer one, however. The Windows area in Figure 11-35 represents file names that the Windows subsystem can create on an NTFS volume but that MS-DOS and 16-bit Windows applications can't see. This group includes file names longer than the 8.3 format of MS-DOS names, those containing Unicode (international) characters, those with multiple period characters or a beginning period, and those with embedded spaces. For compatibility reasons, when a file is created with such a name, NTFS automatically generates an alternate, MS-DOS-style file name for the file. Windows displays these short names when you use the **/x** option with the **dir** command.

The MS-DOS file names are fully functional aliases for the NTFS files and are stored in the same directory as the long file names. The MFT record for a file with an autogenerated MS-DOS file name is shown in Figure 11-36.

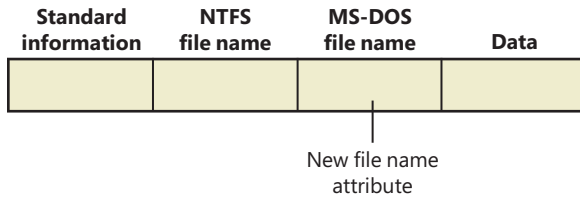

FIGURE 11-36 MFT file record with an MS-DOS file name attribute.

The NTFS name and the generated MS-DOS name are stored in the same file record and therefore refer to the same file. The MS-DOS name can be used to open, read from, write to, or copy the file. If a user renames the file using either the long file name or the short file name, the new name replaces both the existing names. If the new name isn't a valid MS-DOS name, NTFS generates another MS-DOS name for the file. (Note that NTFS only generates MS-DOS-style file names for the first file name.)



Note Hard links are implemented in a similar way. When a hard link to a file is created, NTFS adds another file name attribute to the file's MFT file record, and adds an entry in the Index Allocation attribute of the directory in which the new link resides. The two situations differ in one regard, however. When a user deletes a file that has multiple names (hard links), the file record and the file remain in place. The file and its record are deleted only when the last file name (hard link) is deleted. If a file has both an NTFS name and an autogenerated MS-DOS name, however, a user can delete the file using either name.

Here's the algorithm NTFS uses to generate an MS-DOS name from a long file name. The algorithm is actually implemented in the kernel function *RtlGenerate8dot3Name* and can change in future Windows releases. The latter function is also used by other drivers, such as CDFS, FAT, and third-party file systems:

1. Remove from the long name any characters that are illegal in MS-DOS names, including spaces and Unicode characters. Remove preceding and trailing periods. Remove all other embedded periods, except the last one.
2. Truncate the string before the period (if present) to six characters (it may already be six or fewer because this algorithm is applied when any character that is illegal in MS-DOS is present in the name). If it is two or fewer characters, generate and concatenate a four-character hex checksum string. Append the string *~n* (where *n* is a number, starting with 1, that is used to distinguish different files that truncate to the same name). Truncate the string after the period (if present) to three characters.
3. Put the result in uppercase letters. MS-DOS is case-insensitive, and this step guarantees that NTFS won't generate a new name that differs from the old name only in case.
4. If the generated name duplicates an existing name in the directory, increment the *~n* string. If *n* is greater than 4, and a checksum was not concatenated already, truncate the string before the period to two characters and generate and concatenate a four-character hex checksum string.

Table 11-8 shows the long Windows file names from Figure 11-35 and their NTFS-generated MS-DOS versions. The current algorithm and the examples in Figure 11-35 should give you an idea of what NTFS-generated MS-DOS-style file names look like.



Note Since Windows 8.1, by default all the NTFS nonbootable volumes have short name generation disabled. You can disable short name generation even in older version of Windows by setting HKLM\SYSTEM\CurrentControlSet\Control\FileSystem\NtfsDisable8dot3NameCreation in the registry to a DWORD value of 1 and restarting the machine. This could potentially break compatibility with older applications, though.

TABLE 11-8 NTFS-generated file names

Windows Long Name	NTFS-Generated Short Name
LongFileName	LONGFI~1
UnicodeName.FDPL	UNICODE~1
File.Name.With.Dots	FILENA~1.DOT
File.Name2.With.Dots	FILENA~2.DOT
File.Name3.With.Dots	FILENA~3.DOT
File.Name4.With.Dots	FILENA~4.DOT
File.Name5.With.Dots	FIF596~1.DOT
Name With Embedded Spaces	NAMEWI~1
.BeginningDot	BEGINN~1
25¢.two characters	255440~1.TWO
©	6E2D~1

Tunneling

NTFS uses the concept of *tunneling* to allow compatibility with older programs that depend on the file system to cache certain file metadata for a period of time even after the file is gone, such as when it has been deleted or renamed. With tunneling, any new file created with the same name as the original file, and within a certain period of time, will keep some of the same metadata. The idea is to replicate behavior expected by MS-DOS programs when using the *safe save* programming method, in which modified data is copied to a temporary file, the original file is deleted, and then the temporary file is renamed to the original name. The expected behavior in this case is that the renamed temporary file should appear to be the same as the original file; otherwise, the creation time would continuously update itself with each modification (which is how the modified time is used).

NTFS uses tunneling so that when a file name is removed from a directory, its long name and short name, as well as its creation time, are saved into a cache. When a new file is added to a directory, the cache is searched to see whether there is any tunneled data to restore. Because these operations apply to directories, each directory instance has its own cache, which is deleted if the directory is removed.

NTFS will use tunneling for the following series of operations if the names used result in the deletion and re-creation of the same file name:

- Delete + Create
- Delete + Rename
- Rename + Create
- Rename + Rename

By default, NTFS keeps the tunneling cache for 15 seconds, although you can modify this time-out by creating a new value called *MaximumTunnelEntryAgeInSeconds* in the HKLM\SYSTEM\CurrentControlSet\Control\FileSystem registry key. Tunneling can also be completely disabled by creating a new value called *MaximumTunnelEntries* and setting it to 0; however, this will cause older applications to break if they rely on the compatibility behavior. On NTFS volumes that have short name generation disabled (see the previous section), tunneling is disabled by default.

You can see tunneling in action with the following simple experiment in the command prompt:

1. Create a file called file1.
2. Wait for more than 15 seconds (the default tunnel cache timeout).
3. Create a file called file2.
4. Perform a dir /TC. Note the creation times.
5. Rename file1 to file.
6. Rename file2 to file1.
7. Perform a dir /TC. Note that the creation times are identical.

Resident and nonresident attributes

If a file is small, all its attributes and their values (its data, for example) fit within the file record that describes the file. When the value of an attribute is stored in the MFT (either in the file's main file record or an extension record located elsewhere within the MFT), the attribute is called a *resident attribute*. (In Figure 11-37, for example, all attributes are resident.) Several attributes are defined as always being resident so that NTFS can locate nonresident attributes. The standard information and index root attributes are always resident, for example.

Each attribute begins with a standard header containing information about the attribute—information that NTFS uses to manage the attributes in a generic way. The header, which is always resident, records whether the attribute's value is resident or nonresident. For resident attributes, the header also contains the offset from the header to the attribute's value and the length of the attribute's value, as Figure 11-37 illustrates for the file name attribute.

When an attribute's value is stored directly in the MFT, the time it takes NTFS to access the value is greatly reduced. Instead of looking up a file in a table and then reading a succession of allocation

units to find the file's data (as the FAT file system does, for example), NTFS accesses the disk once and retrieves the data immediately.

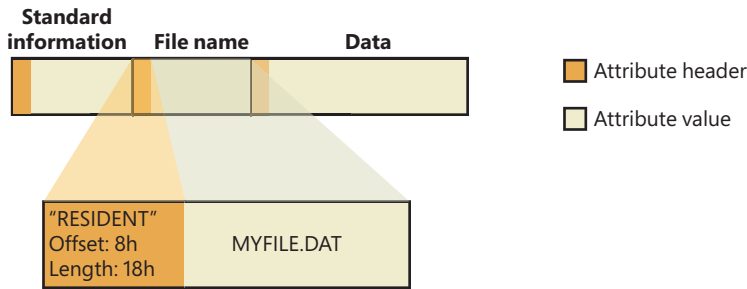

FIGURE 11-37 Resident attribute header and value.

The attributes for a small directory, as well as for a small file, can be resident in the MFT, as Figure 11-38 shows. For a small directory, the index root attribute contains an index (organized as a B-tree) of file record numbers for the files (and the subdirectories) within the directory.

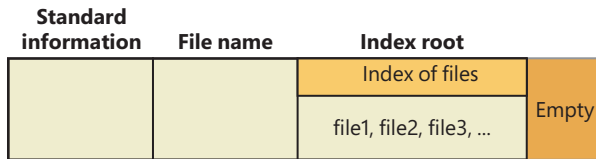

FIGURE 11-38 MFT file record for a small directory.

Of course, many files and directories can't be squeezed into a 1 KB or 4 KB, fixed-size MFT record. If a particular attribute's value, such as a file's data attribute, is too large to be contained in an MFT file record, NTFS allocates clusters for the attribute's value outside the MFT. A contiguous group of clusters is called a *run* (or an *extent*). If the attribute's value later grows (if a user appends data to the file, for example), NTFS allocates another run for the additional data. Attributes whose values are stored in runs (rather than within the MFT) are called *nonresident attributes*. The file system decides whether a particular attribute is resident or nonresident; the location of the data is transparent to the process accessing it.

When an attribute is nonresident, as the data attribute for a large file will certainly be, its header contains the information NTFS needs to locate the attribute's value on the disk. Figure 11-39 shows a nonresident data attribute stored in two runs.

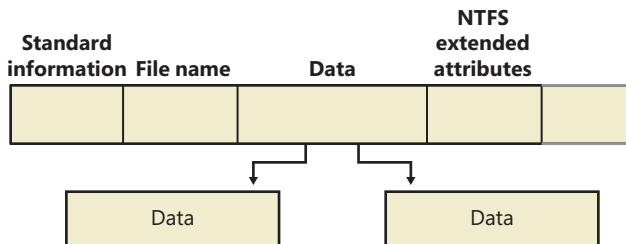

FIGURE 11-39 MFT file record for a large file with two data runs.

Among the standard attributes, only those that can grow can be nonresident. For files, the attributes that can grow are the data and the attribute list (not shown in Figure 11-39). The standard information and file name attributes are always resident.

A large directory can also have nonresident attributes (or parts of attributes), as Figure 11-40 shows. In this example, the MFT file record doesn't have enough room to store the B-tree that contains the index of files that are within this large directory. A part of the index is stored in the index root attribute, and the rest of the index is stored in nonresident runs called *index allocations*. The index root, index allocation, and bitmap attributes are shown here in a simplified form. They are described in more detail in the next section. The standard information and file name attributes are always resident. The header and at least part of the value of the index root attribute are also resident for directories.

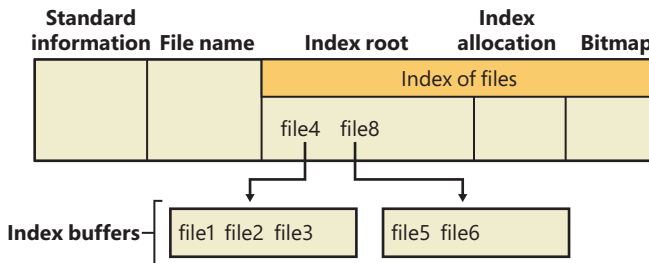

FIGURE 11-40 MFT file record for a large directory with a nonresident file name index.

When an attribute's value can't fit in an MFT file record and separate allocations are needed, NTFS keeps track of the runs by means of VCN-to-LCN mapping pairs. LCNs represent the sequence of clusters on an entire volume from 0 through n . VCNs number the clusters belonging to a particular file from 0 through m . For example, the clusters in the runs of a nonresident data attribute are numbered as shown in Figure 11-41.

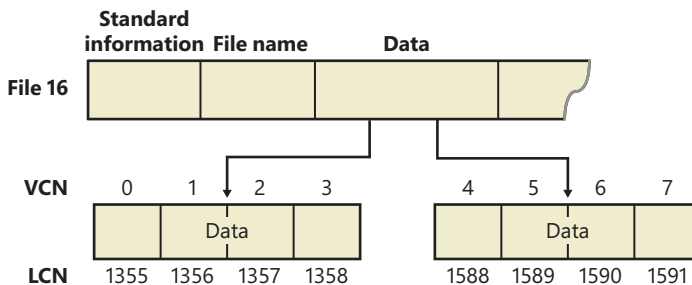

FIGURE 11-41 VCNs for a nonresident data attribute.

If this file had more than two runs, the numbering of the third run would start with VCN 8. As Figure 11-42 shows, the data attribute header contains VCN-to-LCN mappings for the two runs here, which allows NTFS to easily find the allocations on the disk.

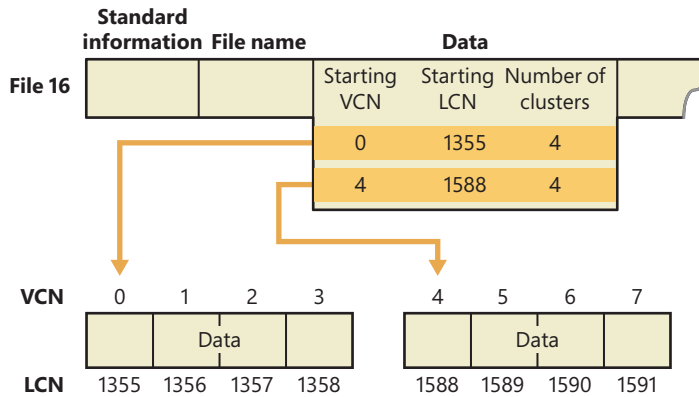

FIGURE 11-42 VCN-to-LCN mappings for a nonresident data attribute.

Although Figure 11-41 shows just data runs, other attributes can be stored in runs if there isn't enough room in the MFT file record to contain them. And if a particular file has too many attributes to fit in the MFT record, a second MFT record is used to contain the additional attributes (or attribute headers for nonresident attributes). In this case, an attribute called the *attribute list* is added. The attribute list attribute contains the name and type code of each of the file's attributes and the file number of the MFT record where the attribute is located. The attribute list attribute is provided for those cases where all of a file's attributes will not fit within the file's file record or when a file grows so large or so fragmented that a single MFT record can't contain the multitude of VCN-to-LCN mappings needed to find all its runs. Files with more than 200 runs typically require an attribute list. In summary, attribute headers are always contained within file records in the MFT, but an attribute's value may be located outside the MFT in one or more extents.

Data compression and sparse files

NTFS supports compression on a per-file, per-directory, or per-volume basis using a variant of the LZ77 algorithm, known as LZNT1. (NTFS compression is performed only on user data, not file system meta-data.) In Windows 8.1 and later, files can also be compressed using a newer suite of algorithms, which include LZX (most compact) and XPRESS (including using 4, 8, or 16K block sizes, in order of speed). This type of compression, which can be used through commands such as the **compact** shell command (as well as File Provider APIs), leverages the Windows Overlay Filter (WOF) file system filter driver (Wof.sys), which uses an NTFS alternate data stream and sparse files, and is not part of the NTFS driver per se. WOF is outside the scope of this book, but you can read more about it here: <https://devblogs.microsoft.com/oldnewthing/20190618-00/?p=102597>.

You can tell whether a volume is compressed by using the Windows *GetVolumeInformation* function. To retrieve the actual compressed size of a file, use the Windows *GetCompressedFileSize* function. Finally, to examine or change the compression setting for a file or directory, use the Windows *DeviceIoControl* function. (See the *FSCTL_GET_COMPRESSION* and *FSCTL_SET_COMPRESSION* file system control codes.) Keep in mind that although setting a file's compression state compresses (or decompresses) the file right away, setting a directory's or volume's compression state doesn't cause any immediate compression or decompression. Instead, setting a directory's or volume's compression state sets a default

compression state that will be given to all newly created files and subdirectories within that directory or volume (although, if you were to set directory compression using the directory's property page within Explorer, the contents of the entire directory tree will be compressed immediately).

The following section introduces NTFS compression by examining the simple case of compressing sparse data. The subsequent sections extend the discussion to the compression of ordinary files and sparse files.



Note NTFS compression is not supported in DAX volumes or for encrypted files.

Compressing sparse data

Sparse data is often large but contains only a small amount of nonzero data relative to its size. A sparse matrix is one example of sparse data. As described earlier, NTFS uses VCNs, from 0 through m , to enumerate the clusters of a file. Each VCN maps to a corresponding LCN, which identifies the disk location of the cluster. Figure 11-43 illustrates the runs (disk allocations) of a normal, noncompressed file, including its VCNs and the LCNs they map to.

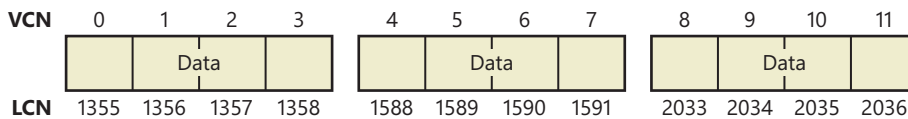

FIGURE 11-43 Runs of a noncompressed file.

This file is stored in three runs, each of which is 4 clusters long, for a total of 12 clusters. Figure 11-44 shows the MFT record for this file. As described earlier, to save space, the MFT record's data attribute, which contains VCN-to-LCN mappings, records only one mapping for each run, rather than one for each cluster. Notice, however, that each VCN from 0 through 11 has a corresponding LCN associated with it. The first entry starts at VCN 0 and covers 4 clusters, the second entry starts at VCN 4 and covers 4 clusters, and so on. This entry format is typical for a noncompressed file.

Standard information	File name	Data		
		Starting VCN	Starting LCN	Number of clusters
		0	1355	4
		4	1588	4
		8	2033	4

FIGURE 11-44 MFT record for a noncompressed file.

When a user selects a file on an NTFS volume for compression, one NTFS compression technique is to remove long strings of zeros from the file. If the file's data is sparse, it typically shrinks to occupy a

fraction of the disk space it would otherwise require. On subsequent writes to the file, NTFS allocates space only for runs that contain nonzero data.

Figure 11-45 depicts the runs of a compressed file containing sparse data. Notice that certain ranges of the file's VCNs (16–31 and 64–127) have no disk allocations.

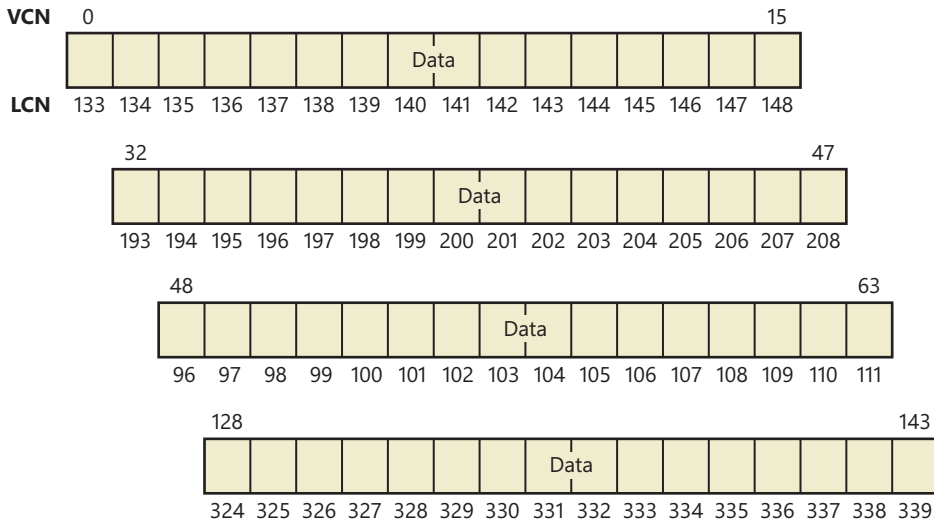

FIGURE 11-45 Runs of a compressed file containing sparse data.

The MFT record for this compressed file omits blocks of VCNs that contain zeros and therefore have no physical storage allocated to them. The first data entry in Figure 11-46, for example, starts at VCN 0 and covers 16 clusters. The second entry jumps to VCN 32 and covers 16 clusters.

Standard information	File name	Data		
		Starting VCN	Starting LCN	Number of clusters
		0	133	16
		32	193	16
		48	96	16
		128	324	16

FIGURE 11-46 MFT record for a compressed file containing sparse data.

When a program reads data from a compressed file, NTFS checks the MFT record to determine whether a VCN-to-LCN mapping covers the location being read. If the program is reading from an unallocated “hole” in the file, it means that the data in that part of the file consists of zeros, so NTFS returns zeros without further accessing the disk. If a program writes nonzero data to a “hole,” NTFS quietly allocates disk space and then writes the data. This technique is very efficient for sparse file data that contains a lot of zero data.

Compressing nonsparse data

The preceding example of compressing a sparse file is somewhat contrived. It describes “compression” for a case in which whole sections of a file were filled with zeros, but the remaining data in the file wasn’t affected by the compression. The data in most files isn’t sparse, but it can still be compressed by the application of a compression algorithm.

In NTFS, users can specify compression for individual files or for all the files in a directory. (New files created in a directory marked for compression are automatically compressed—existing files must be compressed individually when programmatically enabling compression with `FSCTL_SET_COMPRESSION`.) When it compresses a file, NTFS divides the file’s unprocessed data into *compression units* 16 clusters long (equal to 128 KB for a 8 KB cluster, for example). Certain sequences of data in a file might not compress much, if at all; so for each compression unit in the file, NTFS determines whether compressing the unit will save at least 1 cluster of storage. If compressing the unit won’t free up at least 1 cluster, NTFS allocates a 16-cluster run and writes the data in that unit to disk without compressing it. If the data in a 16-cluster unit will compress to 15 or fewer clusters, NTFS allocates only the number of clusters needed to contain the compressed data and then writes it to disk. Figure 11-47 illustrates the compression of a file with four runs. The unshaded areas in this figure represent the actual storage locations that the file occupies after compression. The first, second, and fourth runs were compressed; the third run wasn’t. Even with one noncompressed run, compressing this file saved 26 clusters of disk space, or 41%.

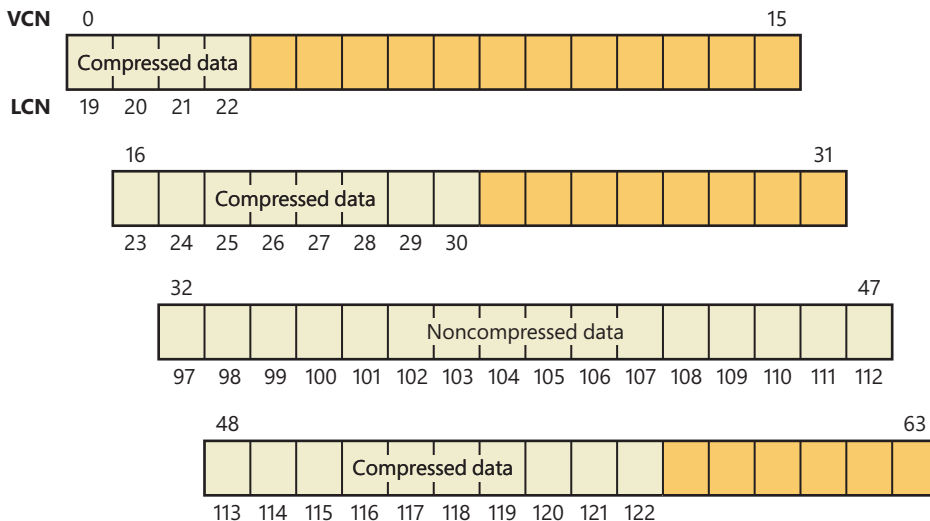

FIGURE 11-47 Data runs of a compressed file.



Note Although the diagrams in this chapter show contiguous LCNs, a compression unit need not be stored in physically contiguous clusters. Runs that occupy noncontiguous clusters produce slightly more complicated MFT records than the one shown in Figure 11-47.

When it writes data to a compressed file, NTFS ensures that each run begins on a virtual 16-cluster boundary. Thus the starting VCN of each run is a multiple of 16, and the runs are no longer than 16 clusters. NTFS reads and writes at least one compression unit at a time when it accesses compressed files. When it writes compressed data, however, NTFS tries to store compression units in physically contiguous locations so that it can read them all in a single I/O operation. The 16-cluster size of the NTFS compression unit was chosen to reduce internal fragmentation: the larger the compression unit, the less the overall disk space needed to store the data. This 16-cluster compression unit size represents a trade-off between producing smaller compressed files and slowing read operations for programs that randomly access files. The equivalent of 16 clusters must be decompressed for each cache miss. (A cache miss is more likely to occur during random file access.) Figure 11-48 shows the MFT record for the compressed file shown in Figure 11-47.

Standard information	File name	Data		
		Starting VCN	Starting LCN	Number of clusters
		0	19	4
		16	23	8
		32	97	16
		48	113	10

FIGURE 11-48 MFT record for a compressed file.

One difference between this compressed file and the earlier example of a compressed file containing sparse data is that three of the compressed runs in this file are less than 16 clusters long. Reading this information from a file's MFT file record enables NTFS to know whether data in the file is compressed. Any run shorter than 16 clusters contains compressed data that NTFS must decompress when it first reads the data into the cache. A run that is exactly 16 clusters long doesn't contain compressed data and therefore requires no decompression.

If the data in a run has been compressed, NTFS decompresses the data into a scratch buffer and then copies it to the caller's buffer. NTFS also loads the decompressed data into the cache, which makes subsequent reads from the same run as fast as any other cached read. NTFS writes any updates to the file to the cache, leaving the lazy writer to compress and write the modified data to disk asynchronously. This strategy ensures that writing to a compressed file produces no more significant delay than writing to a noncompressed file would.

NTFS keeps disk allocations for a compressed file contiguous whenever possible. As the LCNs indicate, the first two runs of the compressed file shown in Figure 11-47 are physically contiguous, as are the last two. When two or more runs are contiguous, NTFS performs disk read-ahead, as it does with the data in other files. Because the reading and decompression of contiguous file data take place asynchronously before the program requests the data, subsequent read operations obtain the data directly from the cache, which greatly enhances read performance.

Sparse files

Sparse files (the NTFS file type, as opposed to files that consist of sparse data, as described earlier) are essentially compressed files for which NTFS doesn't apply compression to the file's nonsparse data. However, NTFS manages the run data of a sparse file's MFT record the same way it does for compressed files that consist of sparse and nonsparse data.

The change journal file

The change journal file, `\$Extend\$UsnJrnl`, is a sparse file in which NTFS stores records of changes to files and directories. Applications like the Windows File Replication Service (FRS) and the Windows Search service make use of the journal to respond to file and directory changes as they occur.

The journal stores change entries in the `$J` data stream and the maximum size of the journal in the `$Max` data stream. Entries are versioned and include the following information about a file or directory change:

- The time of the change
- The reason for the change (see Table 11-9)
- The file or directory's attributes
- The file or directory's name
- The file or directory's MFT file record number
- The file record number of the file's parent directory
- The security ID
- The update sequence number (USN) of the record
- Additional information about the source of the change (a user, the FRS, and so on)

TABLE 11-9 Change journal change reasons

Identifier	Reason
USN_REASON_DATA_OVERWRITE	The data in the file or directory was overwritten.
USN_REASON_DATA_EXTEND	Data was added to the file or directory.
USN_REASON_DATA_TRUNCATION	The data in the file or directory was truncated.
USN_REASON_NAMED_DATA_OVERWRITE	The data in a file's data stream was overwritten.
USN_REASON_NAMED_DATA_EXTEND	The data in a file's data stream was extended.
USN_REASON_NAMED_DATA_TRUNCATION	The data in a file's data stream was truncated.
USN_REASON_FILE_CREATE	A new file or directory was created.
USN_REASON_FILE_DELETE	A file or directory was deleted.
USN_REASON_EA_CHANGE	The extended attributes for a file or directory changed.
USN_REASON_SECURITY_CHANGE	The security descriptor for a file or directory was changed.
USN_REASON_RENAME_OLD_NAME	A file or directory was renamed; this is the old name.

Identifier	Reason
USN_REASON_RENAME_NEW_NAME	A file or directory was renamed; this is the new name.
USN_REASON_INDEXABLE_CHANGE	The indexing state for the file or directory was changed (whether or not the Indexing service will process this file or directory).
USN_REASON_BASIC_INFO_CHANGE	The file or directory attributes and/or the time stamps were changed.
USN_REASON_HARD_LINK_CHANGE	A hard link was added or removed from the file or directory.
USN_REASON_COMPRESSION_CHANGE	The compression state for the file or directory was changed.
USN_REASON_ENCRYPTION_CHANGE	The encryption state (EFS) was enabled or disabled for this file or directory.
USN_REASON_OBJECT_ID_CHANGE	The object ID for this file or directory was changed.
USN_REASON_REPARSE_POINT_CHANGE	The reparse point for a file or directory was changed, or a new reparse point (such as a symbolic link) was added or deleted from a file or directory.
USN_REASON_STREAM_CHANGE	A new data stream was added to or removed from a file or renamed.
USN_REASON_TRANSACTED_CHANGE	This value is added (ORed) to the change reason to indicate that the change was the result of a recent commit of a TxF transaction.
USN_REASON_CLOSE	The handle to a file or directory was closed, indicating that this is the final modification made to the file in this series of operations.
USN_REASON_INTEGRITY_CHANGE	The content of a file's extent (run) has changed, so the associated integrity stream has been updated with a new checksum. This Identifier is generated by the ReFS file system.
USN_REASON_DESIRED_STORAGE_CLASS_CHANGE	The event is generated by the NTFS file system driver when a stream is moved from the capacity to the performance tier or vice versa.

EXPERIMENT: Reading the change journal

You can use the built-in %SystemRoot%\System32\Fsutil.exe tool to create, delete, or query journal information with the built-in Fsutil.exe utility, as shown here:

```
d:\>fsutil usn queryjournal d:
Usn Journal ID   : 0x01d48f4c3853cc72
First Usn       : 0x0000000000000000
Next Usn        : 0x00000000000000a60
Lowest Valid Usn : 0x00000000000000000
Max Usn         : 0x7ffffffffffff0000
Maximum Size    : 0x0000000000a00000
Allocation Delta : 0x0000000000200000
Minimum record version supported : 2
Maximum record version supported : 4
Write range tracking: Disabled
```

The output indicates the maximum size of the change journal on the volume (10 MB) and its current state. As a simple experiment to see how NTFS records changes in the journal, create a file called Usn.txt in the current directory, rename it to UsnNew.txt, and then dump the journal with Fsutil, as shown here:

```
d:\>echo Hello USN Journal! > Usn.txt
d:\>ren Usn.txt UsnNew.txt
```

```
d:\>fsutil usn readjournal d:
```

```
...
```

```
Usn          : 2656
File name    : Usn.txt
File name length : 14
Reason      : 0x00000100: File create
Time stamp   : 12/8/2018 15:22:05
File attributes : 0x00000020: Archive
File ID      : 00000000000000000000c000000617912
Parent file ID : 0000000000000000000018000000617ab6
Source info   : 0x00000000: *NONE*
Security ID   : 0
Major version : 3
Minor version : 0
Record length : 96
```

```
Usn          : 2736
File name    : Usn.txt
File name length : 14
Reason      : 0x00000102: Data extend | File create
Time stamp   : 12/8/2018 15:22:05
File attributes : 0x00000020: Archive
File ID      : 00000000000000000000c000000617912
Parent file ID : 0000000000000000000018000000617ab6
Source info   : 0x00000000: *NONE*
Security ID   : 0
Major version : 3
Minor version : 0
Record length : 96
```

```
Usn          : 2816
File name    : Usn.txt
File name length : 14
Reason      : 0x80000102: Data extend | File create | Close
Time stamp   : 12/8/2018 15:22:05
File attributes : 0x00000020: Archive
File ID      : 00000000000000000000c000000617912
Parent file ID : 0000000000000000000018000000617ab6
Source info   : 0x00000000: *NONE*
Security ID   : 0
Major version : 3
Minor version : 0
Record length : 96
```

```
Usn          : 2896
File name    : Usn.txt
File name length : 14
Reason      : 0x00001000: Rename: old name
Time stamp   : 12/8/2018 15:22:15
File attributes : 0x00000020: Archive
File ID      : 00000000000000000000c000000617912
Parent file ID : 0000000000000000000018000000617ab6
Source info   : 0x00000000: *NONE*
Security ID   : 0
```



```

Major version      : 3
Minor version      : 0
Record length      : 96

Usn                : 2976
File name          : UsnNew.txt
File name length   : 20
Reason             : 0x00002000: Rename: new name
Time stamp         : 12/8/2018 15:22:15
File attributes    : 0x00000020: Archive
File ID            : 000000000000000000c000000617912
Parent file ID     : 00000000000000000018000000617ab6
Source info        : 0x00000000: *NONE*
Security ID        : 0
Major version      : 3
Minor version      : 0
Record length      : 96

```

```

Usn                : 3056
File name          : UsnNew.txt
File name length   : 20
Reason             : 0x80002000: Rename: new name | Close
Time stamp         : 12/8/2018 15:22:15
File attributes    : 0x00000020: Archive
File ID            : 000000000000000000c000000617912
Parent file ID     : 00000000000000000018000000617ab6
Source info        : 0x00000000: *NONE*
Security ID        : 0
Major version      : 3
Minor version      : 0
Record length      : 96

```

The entries reflect the individual modification operations involved in the operations underlying the command-line operations. If the change journal isn't enabled on a volume (this happens especially on non-system volumes where no applications have requested file change notification or the USN Journal creation), you can easily create it with the following command (in the example a 10-MB journal has been requested):

```
d:\ >fsutil usn createJournal d: m=10485760 a=2097152
```

The journal is sparse so that it never overflows; when the journal's on-disk size exceeds the maximum defined for the file, NTFS simply begins zeroing the file data that precedes the window of change information having a size equal to the maximum journal size, as shown in Figure 11-49. To prevent constant resizing when an application is continuously exceeding the journal's size, NTFS shrinks the journal only when its size is twice an application-defined value over the maximum configured size.

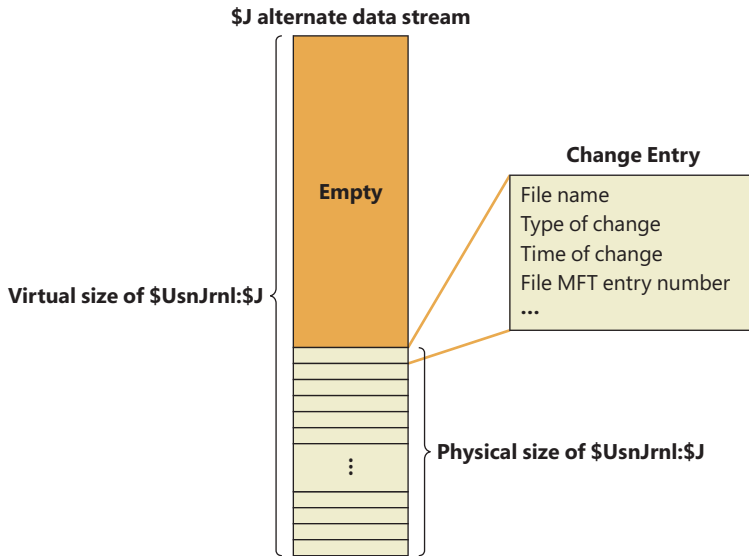

FIGURE 11-49 Change journal (\$UsnJrnl) space allocation.

Indexing

In NTFS, a file directory is simply an index of file names—that is, a collection of file names (along with their file record numbers) organized as a B-tree. To create a directory, NTFS indexes the file name attributes of the files in the directory. The MFT record for the root directory of a volume is shown in Figure 11-50.

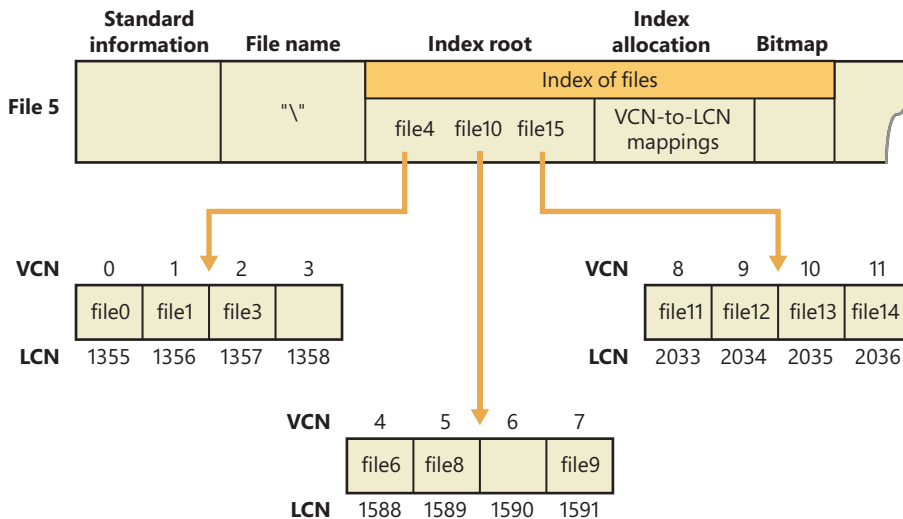

FIGURE 11-50 File name index for a volume's root directory.

Conceptually, an MFT entry for a directory contains in its index root attribute a sorted list of the files in the directory. For large directories, however, the file names are actually stored in 4 KB, fixed-size index buffers (which are the nonresident values of the *index allocation* attribute) that contain and organize the file names. Index buffers implement a B-tree data structure, which minimizes the number of disk accesses needed to find a particular file, especially for large directories. The *index root* attribute contains the first level of the B-tree (root subdirectories) and points to index buffers containing the next level (more subdirectories, perhaps, or files).

Figure 11-50 shows only file names in the index root attribute and the index buffers (*file6*, for example), but each entry in an index also contains the record number in the MFT where the file is described and time stamp and file size information for the file. NTFS duplicates the time stamps and file size information from the file's MFT record. This technique, which is used by FAT and NTFS, requires updated information to be written in two places. Even so, it's a significant speed optimization for directory browsing because it enables the file system to display each file's time stamps and size without opening every file in the directory.

The index allocation attribute maps the VCNs of the index buffer runs to the LCNs that indicate where the index buffers reside on the disk, and the bitmap attribute keeps track of which VCNs in the index buffers are in use and which are free. Figure 11-50 shows one file entry per VCN (that is, per cluster), but file name entries are actually packed into each cluster. Each 4 KB index buffer will typically contain about 20 to 30 file name entries (depending on the lengths of the file names within the directory).

The B-tree data structure is a type of balanced tree that is ideal for organizing sorted data stored on a disk because it minimizes the number of disk accesses needed to find an entry. In the MFT, a directory's index root attribute contains several file names that act as indexes into the second level of the B-tree. Each file name in the index root attribute has an optional pointer associated with it that points to an index buffer. The index buffer points to containing file names with lexicographic values less than its own. In Figure 11-50, for example, *file4* is a first-level entry in the B-tree. It points to an index buffer containing file names that are (lexicographically) less than itself—the file names *file0*, *file1*, and *file3*. Note that the names *file1*, *file3*, and so on that are used in this example are not literal file names but names intended to show the relative placement of files that are lexicographically ordered according to the displayed sequence.

Storing the file names in B-trees provides several benefits. Directory lookups are fast because the file names are stored in a sorted order. And when higher-level software enumerates the files in a directory, NTFS returns already-sorted names. Finally, because B-trees tend to grow wide rather than deep, NTFS's fast lookup times don't degrade as directories grow.

NTFS also provides general support for indexing data besides file names, and several NTFS features—including object IDs, quota tracking, and consolidated security—use indexing to manage internal data.

The B-tree indexes are a generic capability of NTFS and are used for organizing security descriptors, security IDs, object IDs, disk quota records, and reparse points. Directories are referred to as *file name indexes*, whereas other types of indexes are known as *view indexes*.

Object IDs

In addition to storing the object ID assigned to a file or directory in the `$OBJECT_ID` attribute of its MFT record, NTFS also keeps the correspondence between object IDs and their file record numbers in the `$O` index of the `\$Extend\$ObjId` metadata file. The index collates entries by object ID (which is a GUID), making it easy for NTFS to quickly locate a file based on its ID. This feature allows applications, using the `NtCreateFile` native API with the `FILE_OPEN_BY_FILE_ID` flag, to open a file or directory using its object ID. Figure 11-51 demonstrates the correspondence of the `$ObjId` metadata file and `$OBJECT_ID` attributes in MFT records.

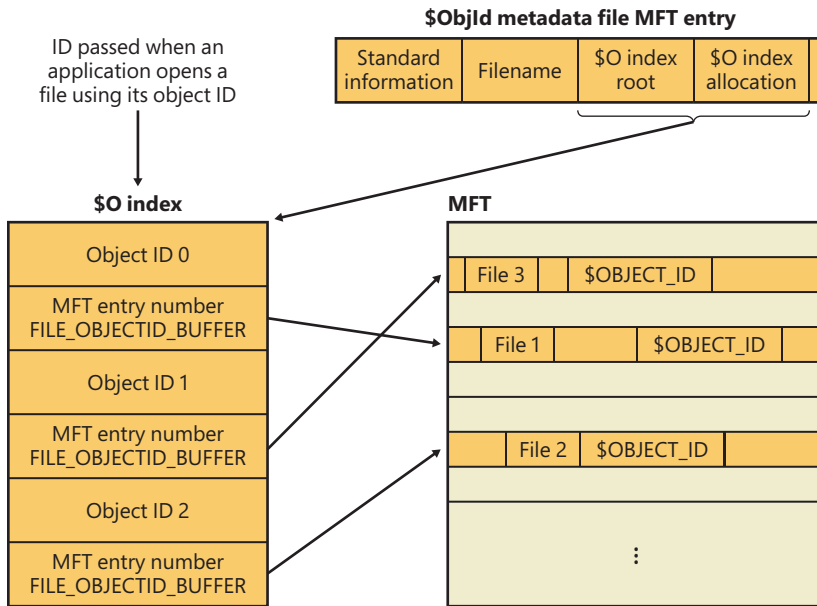

FIGURE 11-51 `$ObjId` and `$OBJECT_ID` relationships.

Quota tracking

NTFS stores quota information in the `\$Extend\$Quota` metadata file, which consists of the named index root attributes `$O` and `$Q`. Figure 11-52 shows the organization of these indexes. Just as NTFS assigns each security descriptor a unique internal security ID, NTFS assigns each user a unique user ID. When an administrator defines quota information for a user, NTFS allocates a user ID that corresponds to the user's SID. In the `$O` index, NTFS creates an entry that maps an SID to a user ID and sorts the index by SID; in the `$Q` index, NTFS creates a quota control entry. A quota control entry contains the value of the user's quota limits, as well as the amount of disk space the user consumes on the volume.

When an application creates a file or directory, NTFS obtains the application user's SID and looks up the associated user ID in the `$O` index. NTFS records the user ID in the new file or directory's `$STANDARD_INFORMATION` attribute, which counts all disk space allocated to the file or directory against that user's quota. Then NTFS looks up the quota entry in the `$Q` index and determines whether the new allocation causes the user to exceed his or her warning or limit threshold. When a new allocation causes the user to

exceed a threshold, NTFS takes appropriate steps, such as logging an event to the System event log or not letting the user create the file or directory. As a file or directory changes size, NTFS updates the quota control entry associated with the user ID stored in the \$STANDARD_INFORMATION attribute. NTFS uses the NTFS generic B-tree indexing to efficiently correlate user IDs with account SIDs and, given a user ID, to efficiently look up a user's quota control information.

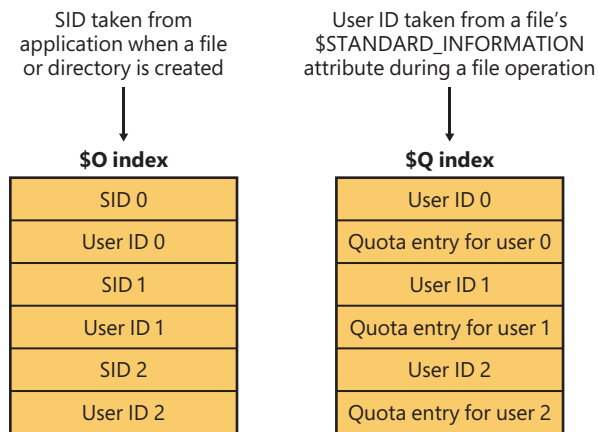

FIGURE 11-52 \$Quota indexing.

Consolidated security

NTFS has always supported security, which lets an administrator specify which users can and can't access individual files and directories. NTFS optimizes disk utilization for security descriptors by using a central metadata file named \$Secure to store only one instance of each security descriptor on a volume.

The \$Secure file contains two index attributes—\$SDH (Security Descriptor Hash) and \$SII (Security ID Index)—and a data-stream attribute named \$SDS (Security Descriptor Stream), as Figure 11-53 shows. NTFS assigns every unique security descriptor on a volume an internal NTFS security ID (not to be confused with a Windows SID, which uniquely identifies computers and user accounts) and hashes the security descriptor according to a simple hash algorithm. A hash is a potentially nonunique shorthand representation of a descriptor. Entries in the \$SDH index map the security descriptor hashes to the security descriptor's storage location within the \$SDS data attribute, and the \$SII index entries map NTFS security IDs to the security descriptor's location in the \$SDS data attribute.

When you apply a security descriptor to a file or directory, NTFS obtains a hash of the descriptor and looks through the \$SDH index for a match. NTFS sorts the \$SDH index entries according to the hash of their corresponding security descriptor and stores the entries in a B-tree. If NTFS finds a match for the descriptor in the \$SDH index, NTFS locates the offset of the entry's security descriptor from the entry's offset value and reads the security descriptor from the \$SDS attribute. If the hashes match but the security descriptors don't, NTFS looks for another matching entry in the \$SDH index. When NTFS finds a precise match, the file or directory to which you're applying the security descriptor can reference the existing security descriptor in the \$SDS attribute. NTFS makes the reference by reading the NTFS security identifier

from the \$SDH entry and storing it in the file or directory's \$STANDARD_INFORMATION attribute. The NTFS \$STANDARD_INFORMATION attribute, which all files and directories have, stores basic information about a file, including its attributes, time stamp information, and security identifier.

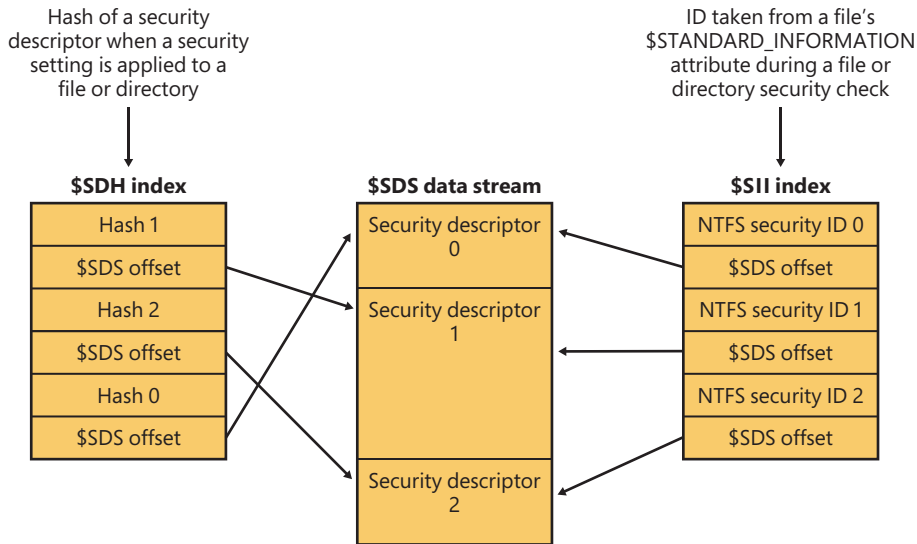

FIGURE 11-53 \$Secure indexing.

If NTFS doesn't find in the \$SDH index an entry that has a security descriptor that matches the descriptor you're applying, the descriptor you're applying is unique to the volume, and NTFS assigns the descriptor a new internal security ID. NTFS internal security IDs are 32-bit values, whereas SIDs are typically several times larger, so representing SIDs with NTFS security IDs saves space in the \$STANDARD_INFORMATION attribute. NTFS then adds the security descriptor to the end of the \$SDS data attribute, and it adds to the \$SDH and \$SII indexes entries that reference the descriptor's offset in the \$SDS data.

When an application attempts to open a file or directory, NTFS uses the \$SII index to look up the file or directory's security descriptor. NTFS reads the file or directory's internal security ID from the MFT entry's \$STANDARD_INFORMATION attribute. It then uses the \$Secure file's \$SII index to locate the ID's entry in the \$SDS data attribute. The offset into the \$SDS attribute lets NTFS read the security descriptor and complete the security check. NTFS stores the 32 most recently accessed security descriptors with their \$SII index entries in a cache so that it accesses the \$Secure file only when the \$SII isn't cached.

NTFS doesn't delete entries in the \$Secure file, even if no file or directory on a volume references the entry. Not deleting these entries doesn't significantly decrease disk space because most volumes, even those used for long periods, have relatively few unique security descriptors.

NTFS's use of generic B-tree indexing lets files and directories that have the same security settings efficiently share security descriptors. The \$SII index lets NTFS quickly look up a security descriptor in the \$Secure file while performing security checks, and the \$SDH index lets NTFS quickly determine whether a security descriptor being applied to a file or directory is already stored in the \$Secure file and can be shared.

Reparse points

As described earlier in the chapter, a *reparse point* is a block of up to 16 KB of application-defined reparse data and a 32-bit reparse tag that are stored in the \$REPARSE_POINT attribute of a file or directory. Whenever an application creates or deletes a reparse point, NTFS updates the \{\$Extend\}Reparse metadata file, in which NTFS stores entries that identify the file record numbers of files and directories that contain reparse points. Storing the records in a central location enables NTFS to provide interfaces for applications to enumerate all a volume's reparse points or just specific types of reparse points, such as mount points. The \{\$Extend\}Reparse file uses the generic B-tree indexing facility of NTFS by collating the file's entries (in an index named \$R) by reparse point tags and file record numbers.

EXPERIMENT: Looking at different reparse points

A file or directory reparse point can contain any kind of arbitrary data. In this experiment, we use the built-in `fsutil.exe` tool to analyze the reparse point content of a symbolic link and of a Modern application's `AppExecutionAlias`, similar to the experiment in Chapter 8. First you need to create a symbolic link:

```
C:\>mklink test_link.txt d:\Test.txt
symbolic link created for test_link.txt <<====>> d:\Test.txt
```

Then you can use the **`fsutil reparsePoint query`** command to examine the reparse point content:

```
C:\>fsutil reparsePoint query test_link.txt
Reparse Tag Value : 0xa000000c
Tag value: Microsoft
Tag value: Name Surrogate
Tag value: Symbolic Link

Reparse Data Length: 0x00000040
Reparse Data:
0000: 16 00 1e 00 00 00 16 00 00 00 00 00 64 00 3a 00 .....d.:.
0010: 5c 00 54 00 65 00 73 00 74 00 2e 00 74 00 78 00 \.T.e.s.t...t.x.
0020: 74 00 5c 00 3f 00 3f 00 5c 00 64 00 3a 00 5c 00 t.\.?.?.\.d.:.\.
0030: 54 00 65 00 73 00 74 00 2e 00 74 00 78 00 74 00 T.e.s.t...t.x.t.
```

As expected, the content is a simple data structure (*REPARSE_DATA_BUFFER*, documented in Microsoft Docs), which contains the symbolic link target and the printed file name. You can even delete the reparse point by using **`fsutil reparsePoint delete`** command:

```
C:\>more test_link.txt
This is a test file!

C:\>fsutil reparsePoint delete test_link.txt

C:\>more test_link.txt
```

If you delete the reparse point, the file become a 0 bytes file. This is by design because the unnamed data stream (\$DATA) in the link file is empty. You can repeat the experiment with an AppExecutionAlias of an installed Modern application (in the following example, Spotify was used):

```
C:\>cd C:\Users\Andrea\AppData\Local\Microsoft\WindowsApps
C:\Users\andrea\AppData\Local\Microsoft\WindowsApps>fsutil reparsePoint query Spotify.exe
Reparse Tag Value : 0x8000001b
Tag value: Microsoft
```

```
Reparse Data Length: 0x00000178
```

```
Reparse Data:
```

```
0000: 03 00 00 00 53 00 70 00 6f 00 74 00 69 00 66 00 ...S.p.o.t.i.f.y.
0010: 79 00 41 00 42 00 2e 00 53 00 70 00 6f 00 74 00 y.A.B...S.p.o.t.
0020: 69 00 66 00 79 00 4d 00 75 00 73 00 69 00 63 00 i.f.y.M.u.s.i.c.
0030: 5f 00 7a 00 70 00 64 00 6e 00 65 00 6b 00 64 00 _.z.p.d.n.e.k.d.
0040: 72 00 7a 00 72 00 65 00 61 00 30 00 00 00 53 00 r.z.r.e.a.O...S
0050: 70 00 6f 00 74 00 69 00 66 00 79 00 41 00 42 00 p.o.t.i.f.y.A.B.
0060: 2e 00 53 00 70 00 6f 00 74 00 69 00 66 00 79 00 ..S.p.o.t.i.f.y.
0070: 4d 00 75 00 73 00 69 00 63 00 5f 00 7a 00 70 00 M.u.s.i.c._.z.p.
0080: 64 00 6e 00 65 00 6b 00 64 00 72 00 7a 00 72 00 d.n.e.k.d.r.z.r.
0090: 65 00 61 00 30 00 21 00 53 00 70 00 6f 00 74 00 e.a.O.!S.p.o.t.
00a0: 69 00 66 00 79 00 00 00 43 00 3a 00 5c 00 50 00 i.f.y...C.:.\.P.
00b0: 72 00 6f 00 67 00 72 00 61 00 6d 00 20 00 46 00 r.o.g.r.a.m. .F.
00c0: 69 00 6c 00 65 00 73 00 5c 00 57 00 69 00 6e 00 i.l.e.s.\.W.i.n.
00d0: 64 00 6f 00 77 00 73 00 41 00 70 00 70 00 73 00 d.o.w.s.A.p.p.s.
00e0: 5c 00 53 00 70 00 6f 00 74 00 69 00 66 00 79 00 \.S.p.o.t.i.f.y.
00f0: 41 00 42 00 2e 00 53 00 70 00 6f 00 74 00 69 00 A.B...S.p.o.t.i.
0100: 66 00 79 00 4d 00 75 00 73 00 69 00 63 00 5f 00 f.y.M.u.s.i.c._.
0110: 31 00 2e 00 39 00 34 00 2e 00 32 00 36 00 32 00 1...9.4...2.6.2.
0120: 2e 00 30 00 5f 00 78 00 38 00 36 00 5f 00 5f 00 ..0._.x.8.6._.
0130: 7a 00 70 00 64 00 6e 00 65 00 6b 00 64 00 72 00 z.p.d.n.e.k.d.r.
0140: 7a 00 72 00 65 00 61 00 30 00 5c 00 53 00 70 00 z.r.e.a.O.\.S.p.
0150: 6f 00 74 00 69 00 66 00 79 00 4d 00 69 00 67 00 o.t.i.f.y.M.i.g.
0160: 72 00 61 00 74 00 6f 00 72 00 2e 00 65 00 78 00 r.a.t.o.r...e.x.
0170: 65 00 00 00 30 00 00 00 e...0...
```

From the preceding output, we can see another kind of reparse point, the AppExecutionAlias, used by Modern applications. More information is available in Chapter 8.

Storage reserves and NTFS reservations

Windows Update and the Windows Setup application must be able to correctly apply important security updates, even when the system volume is almost full (they need to ensure that there is enough disk space). Windows 10 introduced Storage Reserves as a way to achieve this goal. Before we describe the Storage Reserves, it is necessary that you understand how NTFS reservations work and why they're needed.

When the NTFS file system mounts a volume, it calculates the volume's in-use and free space. No on-disk attributes exist for keeping track of these two counters; NTFS maintains and stores the Volume bitmap on disk, which represents the state of all the clusters in the volume. The NTFS mounting code scans the bitmap and counts the number of used clusters, which have their bit set to 1 in the bitmap,

and, through a simple equation (total number of clusters of the volume minus the number of used ones), calculates the number of free clusters. The two calculated counters are stored in the *volume control block* (VCB) data structure, which represents the mounted volume and exists only in memory until the volume is dismounted.

During normal volume I/O activity, NTFS must maintain the total number of reserved clusters. This counter needs to exist for the following reasons:

- When writing to compressed and sparse files, the system must ensure that the entire file is writable because an application that is operating on this kind of file could potentially store valid uncompressed data on the entire file.
- The first time a writable image-backed section is created, the file system must reserve available space for the entire section size, even if no physical space is still allocated in the volume.
- The USN Journal and TxF use the counter to ensure that there is space available for the USN log and NTFS transactions.

NTFS maintains another counter during normal I/O activities, *Total Free Available Space*, which is the final space that a user can see and use for storing new files or data. These three concepts are parts of NTFS Reservations. The important characteristic of NTFS Reservations is that the counters are only in-memory volatile representations, which will be destroyed at volume dismounting time.

Storage Reserve is a feature based on NTFS reservations, which allow files to have an assigned Storage Reserve area. Storage Reserve defines 15 different reservation areas (2 of which are reserved by the OS), which are defined and stored both in memory and in the NTFS on-disk data structures.

To use the new on-disk reservations, an application defines a volume's Storage Reserve area by using the *FSCTL_QUERY_STORAGE_RESERVE* file system control code, which specifies, through a data structure, the total amount of reserved space and an Area ID. This will update multiple counters in the VCB (Storage Reserve areas are maintained in-memory) and insert new data in the *\$SRAT* named data stream of the *\$Bitmap* metadata file. The *\$SRAT* data stream contains a data structure that tracks each Reserve area, including the number of reserved and used clusters. An application can query information about Storage Reserve areas through the *FSCTL_QUERY_STORAGE_RESERVE* file system control code and can delete a Storage Reserve using the *FSCTL_DELETE_STORAGE_RESERVE* code.

After a Storage Reserve area is defined, the application is guaranteed that the space will no longer be used by any other components. Applications can then assign files and directories to a Storage Reserve area using the *NtSetInformationFile* native API with the *FileStorageReserveIdInformationEx* information class. The NTFS file system driver manages the request by updating the in-memory reserved and used clusters counters of the Reserve area, and by updating the volume's total number of reserved clusters that belong to NTFS reservations. It also stores and updates the on-disk *\$STANDARD_INFO* attribute of the target file. The latter maintains 4 bits to store the Storage Reserve area ID. In this way, the system is able to quickly enumerate each file that belongs to a reserve area by just parsing MFT entries. (NTFS implements the enumeration in the *FSCTL_QUERY_FILE_LAYOUT* code's dispatch function.) A user can enumerate the files that belong to a Storage Reserve by using the **fsutil storageReserve findByID** command, specifying the volume path name and Storage Reserve ID she is interested in.

Several basic file operations have new side effects due to Storage Reserves, like file creation and renaming. Newly created files or directories will automatically inherit the storage reserve ID of their parent; the same applies for files or directories that get renamed (moved) to a new parent. Since a rename operation can change the Storage Reserve ID of the file or directory, this implies that the operation might fail due to lack of disk space. Moving a nonempty directory to a new parent implies that the new Storage Reserve ID is recursively applied to all the files and subdirectories. When the reserved space of a Storage Reserve ends, the system starts to use the volume's free available space, so there is no guarantee that the operation always succeeds.

EXPERIMENT: Witnessing storage reserves

Starting from the May 2019 Update of Windows 10 (19H1), you can look at the existing NTFS reserves through the built-in `fsutil.exe` tool:

```
C:\>fsutil storagereserve query c:
Reserve ID:      1
Flags:          0x00000000
Space Guarantee: 0x0                (0 MB)
Space Used:     0x0                (0 MB)

Reserve ID:      2
Flags:          0x00000000
Space Guarantee: 0x0                (0 MB)
Space Used:     0x199ed000         (409 MB)
```

Windows Setup defines two NTFS reserves: a Hard reserve (ID 1), used by the Setup application to store its files, which can't be deleted or replaced by other applications, and a Soft reserve (ID 2), which is used to store temporary files, like system logs and Windows Update downloaded files. In the preceding example, the Setup application has been already able to install all its files (and no Windows Update is executing), so the Hard Reserve is empty; the Soft reserve has all its reserved space allocated. You can enumerate all the files that belong to the reserve using the **`fsutil storagereserve findById`** command. (Be aware that the output is very large, so you might consider redirecting the output to a file using the `>` operator.)

```
C:\>fsutil storagereserve findbyid c: 2
...

***** File 0x0002000000018762 *****
File reference number   : 0x0002000000018762
File attributes        : 0x00000020: Archive
File entry flags       : 0x00000000
Link (ParentID: Name)  : 0x0001000000001165: NTFS Name   :
Windows\System32\winevt\Logs\OALerts.evtx
Link (ParentID: Name)  : 0x0001000000001165: DOS Name     : OALERT~1.EVT
Creation Time          : 12/9/2018 3:26:55
Last Access Time       : 12/10/2018 0:21:57
Last Write Time        : 12/10/2018 0:21:57
Change Time            : 12/10/2018 0:21:57
LastUsn                 : 44,846,752
OwnerId                : 0
SecurityId              : 551
```

```

StorageReserveId      : 2
Stream                : 0x010  ::$STANDARD_INFORMATION
  Attributes          : 0x00000000: *NONE*
  Flags               : 0x0000000c: Resident | No clusters allocated
  Size                : 72
  Allocated Size     : 72
Stream                : 0x030  ::$FILE_NAME
  Attributes          : 0x00000000: *NONE*
  Flags               : 0x0000000c: Resident | No clusters allocated
  Size                : 90
  Allocated Size     : 96
Stream                : 0x030  ::$FILE_NAME
  Attributes          : 0x00000000: *NONE*
  Flags               : 0x0000000c: Resident | No clusters allocated
  Size                : 90
  Allocated Size     : 96
Stream                : 0x080  ::$DATA
  Attributes          : 0x00000000: *NONE*
  Flags               : 0x00000000: *NONE*
  Size                : 69,632
  Allocated Size     : 69,632
  Extents             : 1 Extents
                    : 1: VCN: 0 Clusters: 17 LCN: 3,820,235

```

Transaction support

By leveraging the Kernel Transaction Manager (KTM) support in the kernel, as well as the facilities provided by the Common Log File System, NTFS implements a transactional model called *transactional NTFS* or *TxF*. TxF provides a set of user-mode APIs that applications can use for transacted operations on their files and directories and also a file system control (FSCTL) interface for managing its resource managers.



Note Windows Vista added the support for TxF as a means to introduce atomic transactions to Windows. The NTFS driver was modified without actually changing the format of the NTFS data structures, which is why the NTFS format version number, 3.1, is the same as it has been since Windows XP and Windows Server 2003. TxF achieves backward compatibility by reusing the attribute type (\$LOGGED_UTILITY_STREAM) that was previously used only for EFS support instead of adding a new one.

TxF is a powerful API, but due to its complexity and various issues that developers need to consider, they have been adopted by a low number of applications. At the time of this writing, Microsoft is considering deprecating TxF APIs in a future version of Windows. For the sake of completeness, we present only a general overview of the TxF architecture in this book.

The overall architecture for TxF, shown in Figure 11-54, uses several components:

- Transacted APIs implemented in the Kernel32.dll library
- A library for reading TxF logs (%SystemRoot%\System32\Txfw32.dll)

- A COM component for TxF logging functionality (%SystemRoot\System32\Txfllog.dll)
- The transactional NTFS library inside the NTFS driver
- The CLFS infrastructure for reading and writing log records

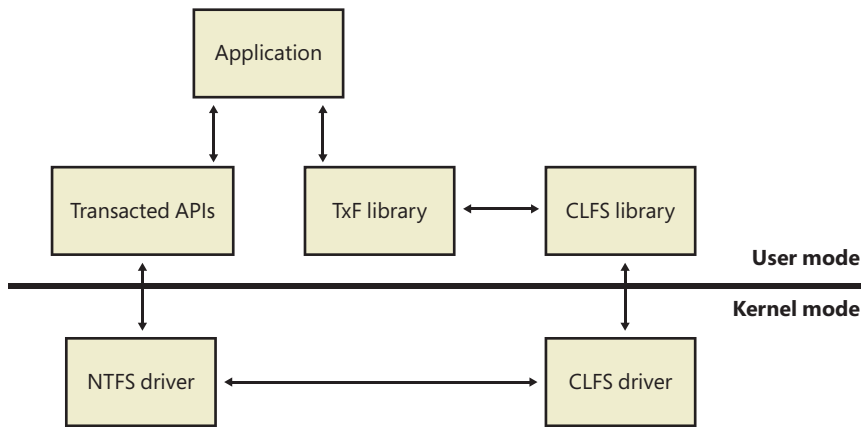

FIGURE 11-54 TxF architecture.

Isolation

Although transactional file operations are opt-in, just like the transactional registry (TxR) operations described in Chapter 10, TxF has an effect on regular applications that are not transaction-aware because it ensures that the transactional operations are *isolated*. For example, if an antivirus program is scanning a file that's currently being modified by another application via a transacted operation, TxF must ensure that the scanner reads the pretransaction data, while applications that access the file within the transaction work with the modified data. This model is called *read-committed isolation*.

Read-committed isolation involves the concept of *transacted writers* and *transacted readers*. The former always view the most up-to-date version of a file, including all changes made by the transaction that is currently associated with the file. At any given time, there can be only one transacted writer for a file, which means that its write access is exclusive. Transacted readers, on the other hand, have access only to the committed version of the file at the time they open the file. They are therefore isolated from changes made by transacted writers. This allows for readers to have a consistent view of a file, even when a transacted writer commits its changes. To see the updated data, the transacted reader must open a new handle to the modified file.

Nontransacted writers, on the other hand, are prevented from opening the file by both transacted writers and transacted readers, so they cannot make changes to the file without being part of the transaction. Nontransacted readers act similarly to transacted readers in that they see only the file contents that were last committed when the file handle was open. Unlike transacted readers, however, they do not receive read-committed isolation, and as such they always receive the updated view of the latest committed version of a transacted file without having to open a new file handle. This allows non-transaction-aware applications to behave as expected.

To summarize, TxF's read-committed isolation model has the following characteristics:

- Changes are isolated from transacted readers.
- Changes are rolled back (undone) if the associated transaction is rolled back, if the machine crashes, or if the volume is forcibly dismounted.
- Changes are flushed to disk if the associated transaction is committed.

Transactional APIs

TxF implements transacted versions of the Windows file I/O APIs, which use the suffix *Transacted*:

- **Create APIs** *CreateDirectoryTransacted, CreateFileTransacted, CreateHardLinkTransacted, CreateSymbolicLinkTransacted*
- **Find APIs** *FindFirstFileNameTransacted, FindFirstFileTransacted, FindFirstStreamTransacted*
- **Query APIs** *GetCompressedFileSizeTransacted, GetFileAttributesTransacted, GetFullPathNameTransacted, GetLongPathNameTransacted*
- **Delete APIs** *DeleteFileTransacted, RemoveDirectoryTransacted*
- **Copy and Move/Rename APIs** *CopyFileTransacted, MoveFileTransacted*
- **Set APIs** *SetFileAttributesTransacted*

In addition, some APIs automatically participate in transacted operations when the file handle they are passed is part of a transaction, like one created by the *CreateFileTransacted* API. Table 11-10 lists Windows APIs that have modified behavior when dealing with a transacted file handle.

TABLE 11-10 API behavior changed by TxF

API Name	Change
<i>CloseHandle</i>	Transactions aren't committed until all applications close transacted handles to the file.
<i>CreateFileMapping, MapViewOfFile</i>	Modifications to mapped views of a file part of a transaction are associated with the transaction themselves.
<i>FindNextFile, ReadDirectoryChanges, GetInformationByHandle, GetFileSize</i>	If the file handle is part of a transaction, read-isolation rules are applied to these operations.
<i>GetVolumeInformation</i>	Function returns <i>FILE_SUPPORTS_TRANSACTIONS</i> if the volume supports TxF.
<i>ReadFile, WriteFile</i>	Read and write operations to a transacted file handle are part of the transaction.
<i>SetFileInformationByHandle</i>	Changes to the <i>FileBasicInfo, FileRenameInfo, FileAllocationInfo, FileEndOfFileInfo, and FileDispositionInfo</i> classes are transacted if the file handle is part of a transaction.
<i>SetEndOfFile, SetFileShortName, SetFileTime</i>	Changes are transacted if the file handle is part of a transaction.

On-disk implementation

As shown earlier in Table 11-7, TxF uses the `$LOGGED_UTILITY_STREAM` attribute type to store additional data for files and directories that are or have been part of a transaction. This attribute is called `$TXF_DATA` and contains important information that allows TxF to keep active offline data for a file part of a transaction. The attribute is permanently stored in the MFT; that is, even after the file is no longer part of a transaction, the stream remains, for reasons explained soon. The major components of the attribute are shown in Figure 11-55.

File record number of RM root
Flags
TxF file ID (TxID)
LSN for NTFS metadata
LSN for user data
LSN for directory index
USN index

FIGURE 11-55 `$TXF_DATA` attribute.

The first field shown is the file record number of the root of the resource manager responsible for the transaction associated with this file. For the default resource manager, the file record number is 5, which is the file record number for the root directory (`\`) in the MFT, as shown earlier in Figure 11-31. TxF needs this information when it creates an FCB for the file so that it can link it to the correct resource manager, which in turn needs to create an enlistment for the transaction when a transacted file request is received by NTFS.

Another important piece of data stored in the `$TXF_DATA` attribute is the *TxF file ID*, or TxID, and this explains why `$TXF_DATA` attributes are never deleted. Because NTFS writes file names to its records when writing to the transaction log, it needs a way to uniquely identify files in the same directory that may have had the same name. For example, if `sample.txt` is deleted from a directory in a transaction and later a new file with the same name is created in the same directory (and as part of the same transaction), TxF needs a way to uniquely identify the two instances of `sample.txt`. This identification is provided by a 64-bit unique number, the TxID, that TxF increments when a new file (or an instance of a file) becomes part of a transaction. Because they can never be reused, TxIDs are permanent, so the `$TXF_DATA` attribute will never be removed from a file.

Last but not least, three CLFS (Common Logging File System) LSNs are stored for each file part of a transaction. Whenever a transaction is active, such as during create, rename, or write operations, TxF writes a log record to its CLFS log. Each record is assigned an LSN, and that LSN gets written to the appropriate field in the `$TXF_DATA` attribute. The first LSN is used to store the log record that identifies the changes to NTFS metadata in relation to this file. For example, if the standard attributes of a file are changed as part of a transacted operation, TxF must update the relevant MFT file record, and the LSN for the log record describing the change is stored. TxF uses the second LSN when the file's data is modified. Finally, TxF uses the third LSN when the file name index for the directory requires a change related to a transaction the file took part in, or when a directory was part of a transaction and received a TxID.

The `$TXF_DATA` attribute also stores internal flags that describe the state information to TxF and the index of the USN record that was applied to the file on commit. A TxF transaction can span multiple USN records that may have been partly updated by NTFS's recovery mechanism (described shortly), so the index tells TxF how many more USN records must be applied after a recovery.

TxF uses a *default* resource manager, one for each volume, to keep track of its transactional state. TxF, however, also supports additional resource managers called secondary resource managers. These resource managers can be defined by application writers and have their metadata located in any directory of the application's choosing, defining their own transactional work units for undo, backup, restore, and redo operations. Both the default resource manager and secondary resource managers contain a number of metadata files and directories that describe their current state:

- The `$Txf` directory, located into `$Extend\RmMetadata` directory, which is where files are linked when they are deleted or overwritten by transactional operations.
- The `$Tops`, or TxF Old Page Stream (TOPS) file, which contains a default data stream and an alternate data stream called `$T`. The default stream for the TOPS file contains metadata about the resource manager, such as its GUID, its CLFS log policy, and the LSN at which recovery should start. The `$T` stream contains file data that is partially overwritten by a transactional writer (as opposed to a full overwrite, which would move the file into the `$Txf` directory).
- The TxF log files, which are CLFS log files storing transaction records. For the default resource manager, these files are part of the `$TxfLog` directory, but secondary resource managers can store them anywhere. TxF uses a multiplexed base log file called `$TxfLog.blf`. The file `\$Extend\RmMetadata\TxfLog\TxfLog` contains two streams: the `KtmLog` stream used for Kernel Transaction Manager metadata records, and the `TxfLog` stream, which contains the TxF log records.

EXPERIMENT: Querying resource manager information

You can use the built-in `Fsutil.exe` command-line program to query information about the default resource manager as well as to create, start, and stop secondary resource managers and configure their logging policies and behaviors. The following command queries information about the default resource manager, which is identified by the root directory (`\`):

```
d:\>fsutil resource info \  
Resource Manager Identifier :      81E83020-E6FB-11E8-B862-D89EF33A38A7  
KTM Log Path for RM:  \Device\HarddiskVolume8\Extend\RmMetadata\TxfLog\TxfLog : KtmLog  
Space used by TOPS:    1 Mb  
TOPS free space:      100%  
RM State:             Active  
Running transactions:  0  
One phase commits:    0  
Two phase commits:    0  
System initiated rollbacks: 0  
Age of oldest transaction: 00:00:00  
Logging Mode:         Simple  
Number of containers:  2
```

```
Container size:      10 Mb
Total log capacity: 20 Mb
Total free log space: 19 Mb
Minimum containers: 2
Maximum containers: 20
Log growth increment: 2 container(s)
Auto shrink:       Not enabled
```

RM prefers availability over consistency.

As mentioned, the **fsutil resource** command has many options for configuring TxF resource managers, including the ability to create a secondary resource manager in any directory of your choice. For example, you can use the **fsutil resource create c:\rmttest** command to create a secondary resource manager in the Rmttest directory, followed by the **fsutil resource start c:\rmttest** command to initiate it. Note the presence of the \$Tops and \$TxfLogContainer* files and of the TxfLog and \$Txf directories in this folder.

Logging implementation

As mentioned earlier, each time a change is made to the disk because of an ongoing transaction, TxF writes a record of the change to its log. TxF uses a variety of log record types to keep track of transactional changes, but regardless of the record type, all TxF log records have a generic header that contains information identifying the type of the record, the action related to the record, the TxID that the record applies to, and the GUID of the KTM transaction that the record is associated with.

A *redo record* specifies how to reapply a change part of a transaction that's already been committed to the volume if the transaction has actually never been flushed from cache to disk. An *undo record*, on the other hand, specifies how to reverse a change part of a transaction that hasn't been committed at the time of a rollback. Some records are redo-only, meaning they don't contain any equivalent undo data, whereas other records contain both redo and undo information.

Through the TOPS file, TxF maintains two critical pieces of data, the *base LSN* and the *restart LSN*. The base LSN determines the LSN of the first valid record in the log, while the restart LSN indicates at which LSN recovery should begin when starting the resource manager. When TxF writes a *restart record*, it updates these two values, indicating that changes have been made to the volume and flushed out to disk—meaning that the file system is fully consistent up to the new restart LSN.

TxF also writes *compensating log records*, or CLR. These records store the actions that are being performed during transaction rollback. They're primarily used to store the *undo-next LSN*, which allows the recovery process to avoid repeated undo operations by bypassing undo records that have already been processed, a situation that can happen if the system fails during the recovery phase and has already performed part of the undo pass. Finally, TxF also deals with *prepare records*, *abort records*, and *commit records*, which describe the state of the KTM transactions related to TxF.

NTFS recovery support

NTFS recovery support ensures that if a power failure or a system failure occurs, no file system operations (transactions) will be left incomplete, and the structure of the disk volume will remain intact without the need to run a disk repair utility. The NTFS Chkdsk utility is used to repair catastrophic disk corruption caused by I/O errors (bad disk sectors, electrical anomalies, or disk failures, for example) or software bugs. But with the NTFS recovery capabilities in place, Chkdsk is rarely needed.

As mentioned earlier (in the section “Recoverability”), NTFS uses a transaction-processing scheme to implement recoverability. This strategy ensures a full disk recovery that is also extremely fast (on the order of seconds) for even the largest disks. NTFS limits its recovery procedures to file system data to ensure that at the very least the user will never lose a volume because of a corrupted file system; however, unless an application takes specific action (such as flushing cached files to disk), NTFS’s recovery support doesn’t guarantee user data to be fully updated if a crash occurs. This is the job of transactional NTFS (TxF).

The following sections detail the transaction-logging scheme NTFS uses to record modifications to file system data structures and explain how NTFS recovers a volume if the system fails.

Design

NTFS implements the design of a *recoverable file system*. These file systems ensure volume consistency by using logging techniques (sometimes called *journaling*) originally developed for transaction processing. If the operating system crashes, the recoverable file system restores consistency by executing a recovery procedure that accesses information that has been stored in a log file. Because the file system has logged its disk writes, the recovery procedure takes only seconds, regardless of the size of the volume (unlike in the FAT file system, where the repair time is related to the volume size). The recovery procedure for a recoverable file system is exact, guaranteeing that the volume will be restored to a consistent state.

A recoverable file system incurs some costs for the safety it provides. Every transaction that alters the volume structure requires that one record be written to the log file for each of the transaction’s sub-operations. This logging overhead is ameliorated by the file system’s *batching* of log records—writing many records to the log file in a single I/O operation. In addition, the recoverable file system can employ the optimization techniques of a lazy write file system. It can even increase the length of the intervals between cache flushes because the file system metadata can be recovered if the system crashes before the cache changes have been flushed to disk. This gain over the caching performance of lazy write file systems makes up for, and often exceeds, the overhead of the recoverable file system’s logging activity.

Neither careful write nor lazy write file systems guarantee protection of user file data. If the system crashes while an application is writing a file, the file can be lost or corrupted. Worse, the crash can corrupt a lazy write file system, destroying existing files or even rendering an entire volume inaccessible.

The NTFS recoverable file system implements several strategies that improve its reliability over that of the traditional file systems. First, NTFS recoverability guarantees that the volume structure won’t be corrupted, so all files will remain accessible after a system failure. Second, although NTFS doesn’t guarantee protection of user data in the event of a system crash—some changes can be lost from the

cache—applications can take advantage of the NTFS write-through and cache-flushing capabilities to ensure that file modifications are recorded on disk at appropriate intervals.

Both *cache write-through*—forcing write operations to be immediately recorded on disk—and *cache flushing*—forcing cache contents to be written to disk—are efficient operations. NTFS doesn't have to do extra disk I/O to flush modifications to several different file system data structures because changes to the data structures are recorded—in a single write operation—in the log file; if a failure occurs and cache contents are lost, the file system modifications can be recovered from the log. Furthermore, unlike the FAT file system, NTFS guarantees that user data will be consistent and available immediately after a write-through operation or a cache flush, even if the system subsequently fails.

Metadata logging

NTFS provides file system recoverability by using the same logging technique used by TxF, which consists of recording all operations that modify file system metadata to a log file. Unlike TxF, however, NTFS's built-in file system recovery support doesn't make use of CLFS but uses an internal logging implementation called the *log file service* (which is not a background service process as described in Chapter 10). Another difference is that while TxF is used only when callers opt in for transacted operations, NTFS records all metadata changes so that the file system can be made consistent in the face of a system failure.

Log file service

The log file service (LFS) is a series of kernel-mode routines inside the NTFS driver that NTFS uses to access the log file. NTFS passes the LFS a pointer to an open file object, which specifies a log file to be accessed. The LFS either initializes a new log file or calls the Windows cache manager to access the existing log file through the cache, as shown in Figure 11-56. Note that although LFS and CLFS have similar sounding names, they're separate logging implementations used for different purposes, although their operation is similar in many ways.

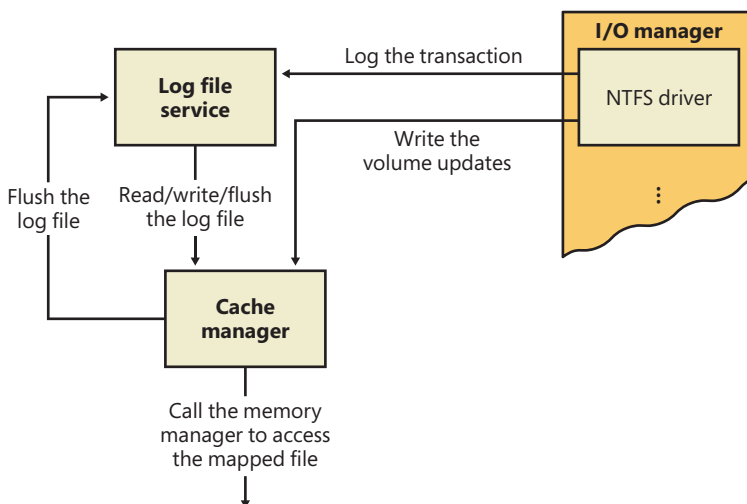

FIGURE 11-56 Log file service (LFS).

The LFS divides the log file into two regions: a *restart area* and an “infinite” *logging area*, as shown in Figure 11-57.

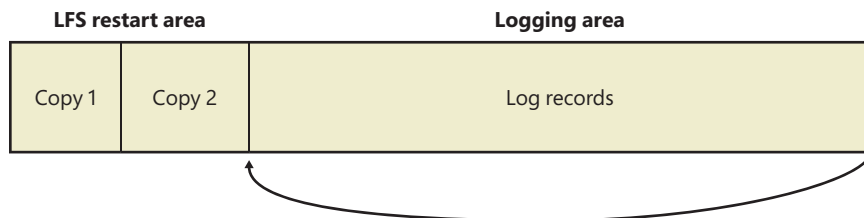

FIGURE 11-57 Log file regions.

NTFS calls the LFS to read and write the restart area. NTFS uses the restart area to store context information such as the location in the logging area at which NTFS begins to read during recovery after a system failure. The LFS maintains a second copy of the restart data in case the first becomes corrupted or otherwise inaccessible. The remainder of the log file is the logging area, which contains transaction records NTFS writes to recover a volume in the event of a system failure. The LFS makes the log file appear infinite by reusing it circularly (while guaranteeing that it doesn’t overwrite information it needs). Just like CLFS, the LFS uses LSNs to identify records written to the log file. As the LFS cycles through the file, it increases the values of the LSNs. NTFS uses 64 bits to represent LSNs, so the number of possible LSNs is so large as to be virtually infinite.

NTFS never reads transactions from or writes transactions to the log file directly. The LFS provides services that NTFS calls to open the log file, write log records, read log records in forward or backward order, flush log records up to a specified LSN, or set the beginning of the log file to a higher LSN. During recovery, NTFS calls the LFS to perform the same actions as described in the TxF recovery section: a redo pass for nonflushed committed changes, followed by an undo pass for noncommitted changes.

Here’s how the system guarantees that the volume can be recovered:

1. NTFS first calls the LFS to record in the (cached) log file any transactions that will modify the volume structure.
2. NTFS modifies the volume (also in the cache).
3. The cache manager prompts the LFS to flush the log file to disk. (The LFS implements the flush by calling the cache manager back, telling it which pages of memory to flush. Refer back to the calling sequence shown in Figure 11-56.)
4. After the cache manager flushes the log file to disk, it flushes the volume changes (the meta-data operations themselves) to disk.

These steps ensure that if the file system modifications are ultimately unsuccessful, the corresponding transactions can be retrieved from the log file and can be either redone or undone as part of the file system recovery procedure.

File system recovery begins automatically the first time the volume is used after the system is re-booted. NTFS checks whether the transactions that were recorded in the log file before the crash were applied to the volume, and if they weren't, it redoes them. NTFS also guarantees that transactions not completely logged before the crash are undone so that they don't appear on the volume.

Log record types

The NTFS recovery mechanism uses similar log record types as the TxF recovery mechanism: *update records*, which correspond to the redo and undo records that TxF uses, and *checkpoint records*, which are similar to the restart records used by TxF. Figure 11-58 shows three update records in the log file. Each record represents one suboperation of a transaction, creating a new file. The redo entry in each update record tells NTFS how to reapply the suboperation to the volume, and the undo entry tells NTFS how to roll back (undo) the suboperation.

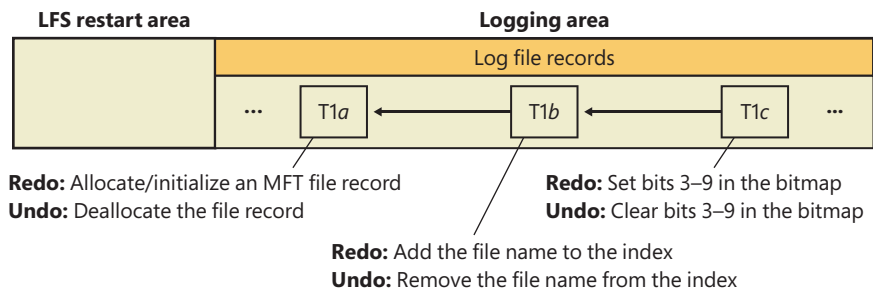

FIGURE 11-58 Update records in the log file.

After logging a transaction (in this example, by calling the LFS to write the three update records to the log file), NTFS performs the suboperations on the volume itself, in the cache. When it has finished updating the cache, NTFS writes another record to the log file, recording the entire transaction as complete—a suboperation known as *committing* a transaction. Once a transaction is committed, NTFS guarantees that the entire transaction will appear on the volume, even if the operating system subsequently fails.

When recovering after a system failure, NTFS reads through the log file and redoes each committed transaction. Although NTFS completed the committed transactions from before the system failure, it doesn't know whether the cache manager flushed the volume modifications to disk in time. The updates might have been lost from the cache when the system failed. Therefore, NTFS executes the committed transactions again just to be sure that the disk is up to date.

After redoing the committed transactions during a file system recovery, NTFS locates all the transactions in the log file that weren't committed at failure and rolls back each suboperation that had been logged. In Figure 11-58, NTFS would first undo the T1c suboperation and then follow the backward pointer to T1b and undo that suboperation. It would continue to follow the backward pointers, undoing suboperations, until it reached the first suboperation in the transaction. By following the pointers, NTFS knows how many and which update records it must undo to roll back a transaction.

Redo and undo information can be expressed either physically or logically. As the lowest layer of software maintaining the file system structure, NTFS writes update records with *physical descriptions* that specify volume updates in terms of particular byte ranges on the disk that are to be changed, moved, and so on, unlike TxF, which uses *logical descriptions* that express updates in terms of operations such as “delete file A.dat.” NTFS writes update records (usually several) for each of the following transactions:

- Creating a file
- Deleting a file
- Extending a file
- Truncating a file
- Setting file information
- Renaming a file
- Changing the security applied to a file

The redo and undo information in an update record must be carefully designed because although NTFS undoes a transaction, recovers from a system failure, or even operates normally, it might try to redo a transaction that has already been done or, conversely, to undo a transaction that never occurred or that has already been undone. Similarly, NTFS might try to redo or undo a transaction consisting of several update records, only some of which are complete on disk. The format of the update records must ensure that executing redundant redo or undo operations is *idempotent*—that is, has a neutral effect. For example, setting a bit that is already set has no effect, but toggling a bit that has already been toggled does. The file system must also handle intermediate volume states correctly.

In addition to update records, NTFS periodically writes a checkpoint record to the log file, as illustrated in Figure 11-59.

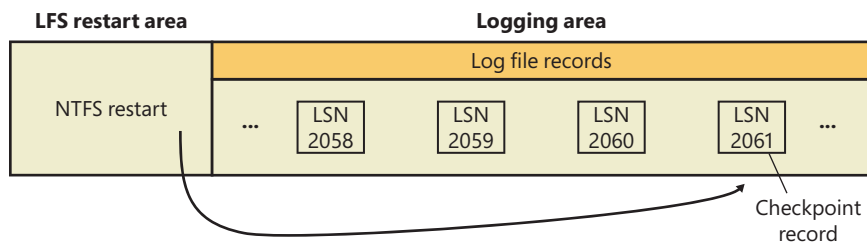

FIGURE 11-59 Checkpoint record in the log file.

A checkpoint record helps NTFS determine what processing would be needed to recover a volume if a crash were to occur immediately. Using information stored in the checkpoint record, NTFS knows, for example, how far back in the log file it must go to begin its recovery. After writing a checkpoint record, NTFS stores the LSN of the record in the restart area so that it can quickly find its most recently written checkpoint record when it begins file system recovery after a crash occurs; this is similar to the restart LSN used by TxF for the same reason.

Although the LFS presents the log file to NTFS as if it were infinitely large, it isn't. The generous size of the log file and the frequent writing of checkpoint records (an operation that usually frees up space in the log file) make the possibility of the log file filling up a remote one. Nevertheless, the LFS, just like CLFS, accounts for this possibility by tracking several operational parameters:

- The available log space
- The amount of space needed to write an incoming log record and to undo the write, should that be necessary
- The amount of space needed to roll back all active (noncommitted) transactions, should that be necessary

If the log file doesn't contain enough available space to accommodate the total of the last two items, the LFS returns a "log file full" error, and NTFS raises an exception. The NTFS exception handler rolls back the current transaction and places it in a queue to be restarted later.

To free up space in the log file, NTFS must momentarily prevent further transactions on files. To do so, NTFS blocks file creation and deletion and then requests exclusive access to all system files and shared access to all user files. Gradually, active transactions either are completed successfully or receive the "log file full" exception. NTFS rolls back and queues the transactions that receive the exception.

Once it has blocked transaction activity on files as just described, NTFS calls the cache manager to flush unwritten data to disk, including unwritten log file data. After everything is safely flushed to disk, NTFS no longer needs the data in the log file. It resets the beginning of the log file to the current position, making the log file "empty." Then it restarts the queued transactions. Beyond the short pause in I/O processing, the log file full error has no effect on executing programs.

This scenario is one example of how NTFS uses the log file not only for file system recovery but also for error recovery during normal operation. You find out more about error recovery in the following section.

Recovery

NTFS automatically performs a disk recovery the first time a program accesses an NTFS volume after the system has been booted. (If no recovery is needed, the process is trivial.) Recovery depends on two tables NTFS maintains in memory: a transaction table, which behaves just like the one TxF maintains, and a *dirty page table*, which records which pages in the cache contain modifications to the file system structure that haven't yet been written to disk. This data must be flushed to disk during recovery.

NTFS writes a checkpoint record to the log file once every 5 seconds. Just before it does, it calls the LFS to store a current copy of the transaction table and of the dirty page table in the log file. NTFS then records in the checkpoint record the LSNs of the log records containing the copied tables. When recovery begins after a system failure, NTFS calls the LFS to locate the log records containing the most recent checkpoint record and the most recent copies of the transaction and dirty page tables. It then copies the tables to memory.

The log file usually contains more update records following the last checkpoint record. These update records represent volume modifications that occurred after the last checkpoint record was

written. NTFS must update the transaction and dirty page tables to include these operations. After updating the tables, NTFS uses the tables and the contents of the log file to update the volume itself.

To perform its volume recovery, NTFS scans the log file three times, loading the file into memory during the first pass to minimize disk I/O. Each pass has a particular purpose:

1. Analysis
2. Redoing transactions
3. Undoing transactions

Analysis pass

During the *analysis pass*, as shown in Figure 11-60, NTFS scans forward in the log file from the beginning of the last checkpoint operation to find update records and use them to update the transaction and dirty page tables it copied to memory. Notice in the figure that the checkpoint operation stores three records in the log file and that update records might be interspersed among these records. NTFS therefore must start its scan at the beginning of the checkpoint operation.

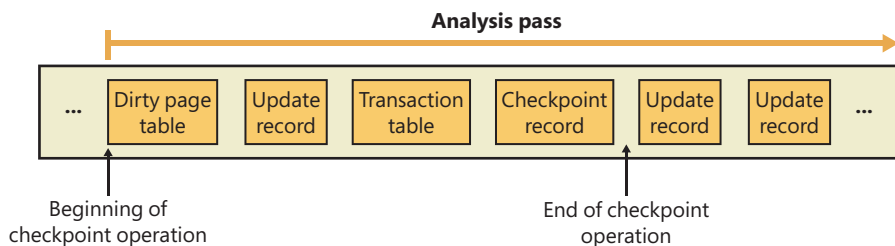

FIGURE 11-60 Analysis pass.

Most update records that appear in the log file after the checkpoint operation begins represent a modification to either the transaction table or the dirty page table. If an update record is a “transaction committed” record, for example, the transaction the record represents must be removed from the transaction table. Similarly, if the update record is a page update record that modifies a file system data structure, the dirty page table must be updated to reflect that change.

Once the tables are up to date in memory, NTFS scans the tables to determine the LSN of the oldest update record that logs an operation that hasn’t been carried out on disk. The transaction table contains the LSNs of the noncommitted (incomplete) transactions, and the dirty page table contains the LSNs of records in the cache that haven’t been flushed to disk. The LSN of the oldest update record that NTFS finds in these two tables determines where the redo pass will begin. If the last checkpoint record is older, however, NTFS will start the redo pass there instead.



Note In the TxF recovery model, there is no distinct analysis pass. Instead, as described in the TxF recovery section, TxF performs the equivalent work in the redo pass.

Redo pass

During the *redo pass*, as shown in Figure 11-61, NTFS scans forward in the log file from the LSN of the oldest update record, which it found during the analysis pass. It looks for page update records, which contain volume modifications that were written before the system failure but that might not have been flushed to disk. NTFS redoes these updates in the cache.

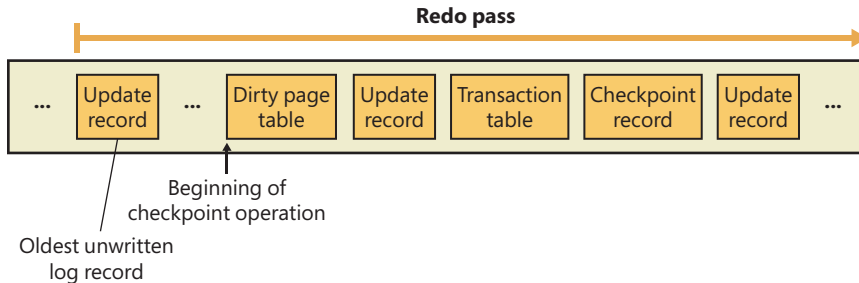

FIGURE 11-61 Redo pass.

When NTFS reaches the end of the log file, it has updated the cache with the necessary volume modifications, and the cache manager's lazy writer can begin writing cache contents to disk in the background.

Undo pass

After it completes the redo pass, NTFS begins its *undo pass*, in which it rolls back any transactions that weren't committed when the system failed. Figure 11-62 shows two transactions in the log file; transaction 1 was committed before the power failure, but transaction 2 wasn't. NTFS must undo transaction 2.

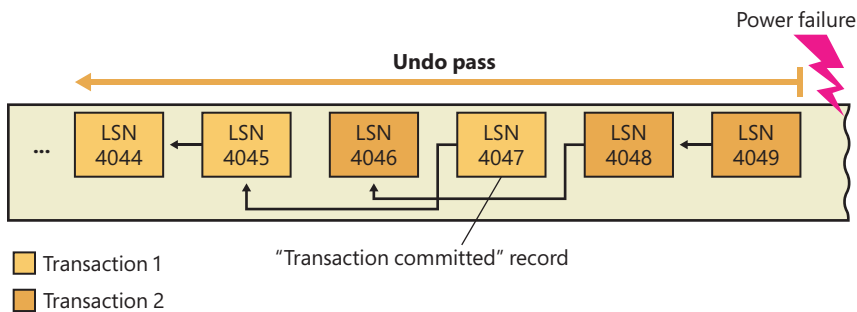

FIGURE 11-62 Undo pass.

Suppose that transaction 2 created a file, an operation that comprises three suboperations, each with its own update record. The update records of a transaction are linked by backward pointers in the log file because they aren't usually contiguous.

The NTFS transaction table lists the LSN of the last-logged update record for each noncommitted transaction. In this example, the transaction table identifies LSN 4049 as the last update record logged for transaction 2. As shown from right to left in Figure 11-63, NTFS rolls back transaction 2.

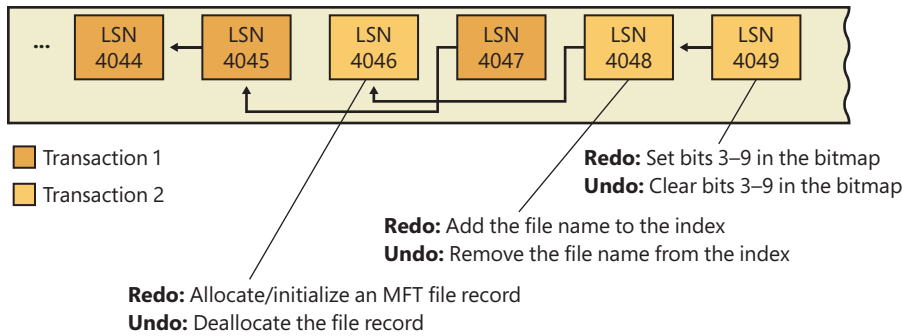

FIGURE 11-63 Undoing a transaction.

After locating LSN 4049, NTFS finds the undo information and executes it, clearing bits 3 through 9 in its allocation bitmap. NTFS then follows the backward pointer to LSN 4048, which directs it to remove the new file name from the appropriate file name index. Finally, it follows the last backward pointer and deallocates the MFT file record reserved for the file, as the update record with LSN 4046 specifies. Transaction 2 is now rolled back. If there are other noncommitted transactions to undo, NTFS follows the same procedure to roll them back. Because undoing transactions affects the volume's file system structure, NTFS must log the undo operations in the log file. After all, the power might fail again during the recovery, and NTFS would have to redo its undo operations!

When the undo pass of the recovery is finished, the volume has been restored to a consistent state. At this point, NTFS is prepared to flush the cache changes to disk to ensure that the volume is up to date. Before doing so, however, it executes a callback that TxF registers for notifications of LFS flushes. Because TxF and NTFS both use write-ahead logging, TxF must flush its log through CLFS before the NTFS log is flushed to ensure consistency of its own metadata. (And similarly, the TOPS file must be flushed before the CLFS-managed log files.) NTFS then writes an "empty" LFS restart area to indicate that the volume is consistent and that no recovery need be done if the system should fail again immediately. Recovery is complete.

NTFS guarantees that recovery will return the volume to some preexisting consistent state, but not necessarily to the state that existed just before the system crash. NTFS can't make that guarantee because, for performance, it uses a lazy commit algorithm, which means that the log file isn't immediately flushed to disk each time a transaction committed record is written. Instead, numerous transaction committed records are batched and written together, either when the cache manager calls the LFS to flush the log file to disk or when the LFS writes a checkpoint record (once every 5 seconds) to the log file. Another reason the recovered volume might not be completely up to date is that several parallel transactions might be active when the system crashes, and some of their transaction committed records might make it to disk, whereas others might not. The consistent volume that recovery produces includes all the volume updates whose transaction committed records made it to disk and none of the updates whose transaction committed records didn't make it to disk.

NTFS uses the log file to recover a volume after the system fails, but it also takes advantage of an important freebie it gets from logging transactions. File systems necessarily contain a lot of code devoted to recovering from file system errors that occur during the course of normal file I/O. Because NTFS logs each transaction that modifies the volume structure, it can use the log file to recover when a file system error occurs and thus can greatly simplify its error handling code. The log file full error described earlier is one example of using the log file for error recovery.

Most I/O errors that a program receives aren't file system errors and therefore can't be resolved entirely by NTFS. When called to create a file, for example, NTFS might begin by creating a file record in the MFT and then enter the new file's name in a directory index. When it tries to allocate space for the file in its bitmap, however, it could discover that the disk is full and the create request can't be completed. In such a case, NTFS uses the information in the log file to undo the part of the operation it has already completed and to deallocate the data structures it reserved for the file. Then it returns a disk full error to the caller, which in turn must respond appropriately to the error.

NTFS bad-cluster recovery

The volume manager included with Windows (VolMgr) can recover data from a bad sector on a fault-tolerant volume, but if the hard disk doesn't perform bad-sector remapping or runs out of spare sectors, the volume manager can't perform bad-sector replacement to replace the bad sector. When the file system reads from the sector, the volume manager instead recovers the data and returns the warning to the file system that there is only one copy of the data.

The FAT file system doesn't respond to this volume manager warning. Moreover, neither FAT nor the volume manager keeps track of the bad sectors, so a user must run the Chkdsk or Format utility to prevent the volume manager from repeatedly recovering data for the file system. Both Chkdsk and Format are less than ideal for removing bad sectors from use. Chkdsk can take a long time to find and remove bad sectors, and Format wipes all the data off the partition it's formatting.

In the file system equivalent of a volume manager's bad-sector replacement, NTFS dynamically replaces the cluster containing a bad sector and keeps track of the bad cluster so that it won't be reused. (Recall that NTFS maintains portability by addressing logical clusters rather than physical sectors.) NTFS performs these functions when the volume manager can't perform bad-sector replacement. When a volume manager returns a bad-sector warning or when the hard disk driver returns a bad-sector error, NTFS allocates a new cluster to replace the one containing the bad sector. NTFS copies the data that the volume manager has recovered into the new cluster to reestablish data redundancy.

Figure 11-64 shows an MFT record for a user file with a bad cluster in one of its data runs as it existed before the cluster went bad. When it receives a bad-sector error, NTFS reassigns the cluster containing the sector to its bad-cluster file, \$BadClus. This prevents the bad cluster from being allocated to another file. NTFS then allocates a new cluster for the file and changes the file's VCN-to-LCN mappings to point to the new cluster. This bad-cluster remapping (introduced earlier in this chapter) is illustrated in Figure 11-64. Cluster number 1357, which contains the bad sector, must be replaced by a good cluster.

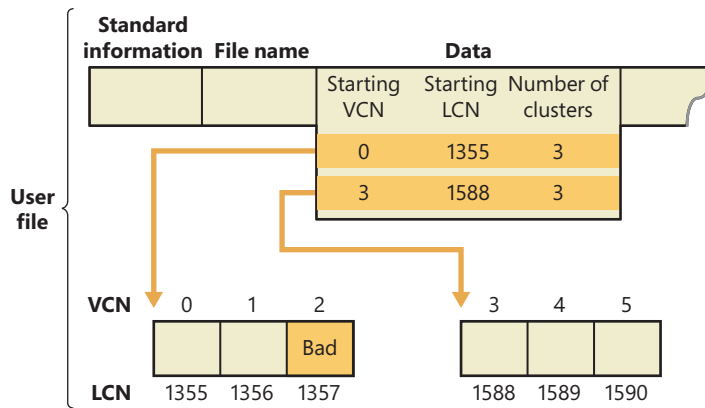

FIGURE 11-64 MFT record for a user file with a bad cluster.

Bad-sector errors are undesirable, but when they do occur, the combination of NTFS and the volume manager provides the best possible solution. If the bad sector is on a redundant volume, the volume manager recovers the data and replaces the sector if it can. If it can't replace the sector, it returns a warning to NTFS, and NTFS replaces the cluster containing the bad sector.

If the volume isn't configured as a redundant volume, the data in the bad sector can't be recovered. When the volume is formatted as a FAT volume and the volume manager can't recover the data, reading from the bad sector yields indeterminate results. If some of the file system's control structures reside in the bad sector, an entire file or group of files (or potentially, the whole disk) can be lost. At best, some data in the affected file (often, all the data in the file beyond the bad sector) is lost. Moreover, the FAT file system is likely to reallocate the bad sector to the same or another file on the volume, causing the problem to resurface.

Like the other file systems, NTFS can't recover data from a bad sector without help from a volume manager. However, NTFS greatly contains the damage a bad sector can cause. If NTFS discovers the bad sector during a read operation, it remaps the cluster the sector is in, as shown in Figure 11-65. If the volume isn't configured as a redundant volume, NTFS returns a data read error to the calling program. Although the data that was in that cluster is lost, the rest of the file—and the file system—remains intact; the calling program can respond appropriately to the data loss, and the bad cluster won't be reused in future allocations. If NTFS discovers the bad cluster on a write operation rather than a read, NTFS remaps the cluster before writing and thus loses no data and generates no error.

The same recovery procedures are followed if file system data is stored in a sector that goes bad. If the bad sector is on a redundant volume, NTFS replaces the cluster dynamically, using the data recovered by the volume manager. If the volume isn't redundant, the data can't be recovered, so NTFS sets a bit in the \$Volume metadata file that indicates corruption on the volume. The NTFS Chkdsk utility checks this bit when the system is next rebooted, and if the bit is set, Chkdsk executes, repairing the file system corruption by reconstructing the NTFS metadata.

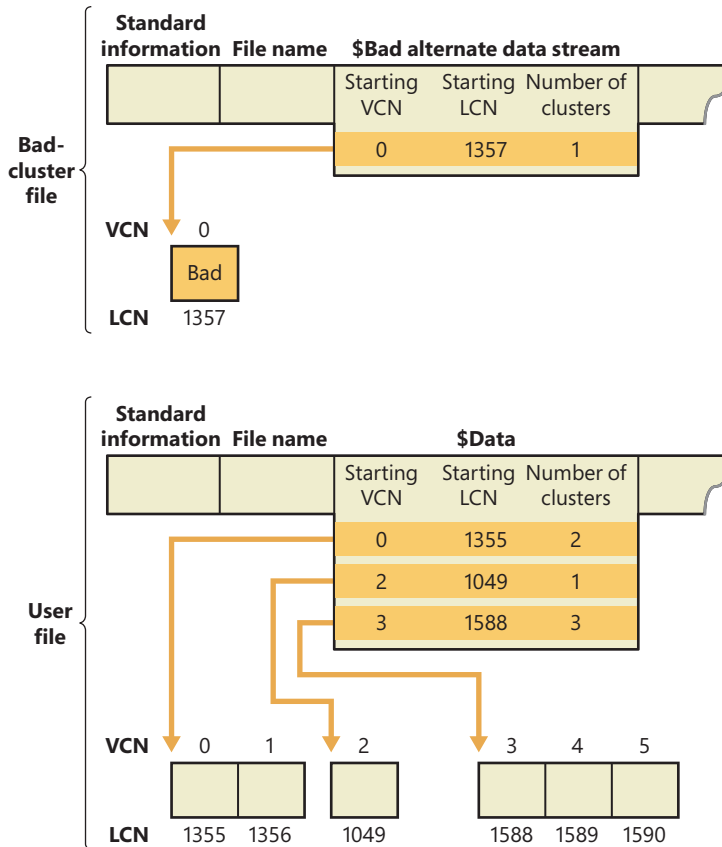

FIGURE 11-65 Bad-cluster remapping.

In rare instances, file system corruption can occur even on a fault-tolerant disk configuration. A double error can destroy both file system data and the means to reconstruct it. If the system crashes while NTFS is writing the mirror copy of an MFT file record—of a file name index or of the log file, for example—the mirror copy of such file system data might not be fully updated. If the system were rebooted and a bad-sector error occurred on the primary disk at exactly the same location as the incomplete write on the disk mirror, NTFS would be unable to recover the correct data from the disk mirror. NTFS implements a special scheme for detecting such corruptions in file system data. If it ever finds an inconsistency, it sets the corruption bit in the volume file, which causes Chkdsk to reconstruct the NTFS metadata when the system is next rebooted. Because file system corruption is rare on a fault-tolerant disk configuration, Chkdsk is seldom needed. It is supplied as a safety precaution rather than as a first-line data recovery strategy.

The use of Chkdsk on NTFS is vastly different from its use on the FAT file system. Before writing anything to disk, FAT sets the volume's dirty bit and then resets the bit after the modification is complete. If any I/O operation is in progress when the system crashes, the dirty bit is left set and Chkdsk runs when the system is rebooted. On NTFS, Chkdsk runs only when unexpected or unreadable file system data is found, and NTFS can't recover the data from a redundant volume or from redundant file system structures on a single volume. (The system boot sector is duplicated—in the last sector

of a volume—as are the parts of the MFT (\$MftMirr) required for booting the system and running the NTFS recovery procedure. This redundancy ensures that NTFS will always be able to boot and recover itself.)

Table 11-11 summarizes what happens when a sector goes bad on a disk volume formatted for one of the Windows-supported file systems according to various conditions we’ve described in this section.

TABLE 11-11 Summary of NTFS data recovery scenarios

Scenario	With a Disk That Supports Bad-Sector Remapping and Has Spare Sectors	With a Disk That Does Not Perform Bad-Sector Remapping or Has No Spare Sectors
Fault-tolerant volume ¹	<ol style="list-style-type: none"> 1. Volume manager recovers the data. 2. Volume manager performs bad-sector replacement. 3. File system remains unaware of the error. 	<ol style="list-style-type: none"> 1. Volume manager recovers the data. 2. Volume manager sends the data and a bad-sector error to the file system. 3. NTFS performs cluster remapping.
Non-fault-tolerant volume	<ol style="list-style-type: none"> 1. Volume manager can’t recover the data. 2. Volume manager sends a bad-sector error to the file system. 3. NTFS performs cluster remapping. Data is lost.² 	<ol style="list-style-type: none"> 1. Volume manager can’t recover the data. 2. Volume manager sends a bad-sector error to the file system. 3. NTFS performs cluster remapping. Data is lost.

1 A fault-tolerant volume is one of the following: a mirror set (RAID-1) or a RAID-5 set.

2 In a write operation, no data is lost: NTFS remaps the cluster before the write.

If the volume on which the bad sector appears is a fault-tolerant volume—a mirrored (RAID-1) or RAID-5 / RAID-6 volume—and if the hard disk is one that supports bad-sector replacement (and that hasn’t run out of spare sectors), it doesn’t matter which file system you’re using (FAT or NTFS). The volume manager replaces the bad sector without the need for user or file system intervention.

If a bad sector is located on a hard disk that doesn’t support bad sector replacement, the file system is responsible for replacing (remapping) the bad sector or—in the case of NTFS—the cluster in which the bad sector resides. The FAT file system doesn’t provide sector or cluster remapping. The benefits of NTFS cluster remapping are that bad spots in a file can be fixed without harm to the file (or harm to the file system, as the case may be) and that the bad cluster will never be used again.

Self-healing

With today’s multiterabyte storage devices, taking a volume offline for a consistency check can result in a service outage of many hours. Recognizing that many disk corruptions are localized to a single file or portion of metadata, NTFS implements a self-healing feature to repair damage while a volume remains online. When NTFS detects corruption, it prevents access to the damaged file or files and creates a system worker thread that performs Chkdsk-like corrections to the corrupted data structures, allowing access to the repaired files when it has finished. Access to other files continues normally during this operation, minimizing service disruption.

You can use the **fsutil repair set** command to view and set a volume’s repair options, which are summarized in Table 11-12. The Fsutil utility uses the *FSCTL_SET_REPAIR* file system control code to set these settings, which are saved in the VCB for the volume.

TABLE 11-12 NTFS self-healing behaviors

Flag	Behavior
SET_REPAIR_ENABLED	Enable self-healing for the volume.
SET_REPAIR_WARN_ABOUT_DATA_LOSS	If the self-healing process is unable to fully recover a file, specifies whether the user should be visually warned.
SET_REPAIR_DISABLED_AND_BUGCHECK_ON_CORRUPTION	If the <code>NtfsBugCheckOnCorrupt</code> NTFS registry value was set by using <code>fsutil</code> behavior set <code>NtfsBugCheckOnCorrupt 1</code> and this flag is set, the system will crash with a STOP error 0x24, indicating file system corruption. This setting is automatically cleared during boot time to avoid repeated reboot cycles.

In all cases, including when the visual warning is disabled (the default), NTFS will log any self-healing operation it undertook in the System event log.

Apart from periodic automatic self-healing, NTFS also supports manually initiated self-healing cycles (this type of self-healing is called *proactive*) through the `FSCTL_INITIATE_REPAIR` and `FSCTL_WAIT_FOR_REPAIR` control codes, which can be initiated with the **fsutil repair initiate** and **fsutil repair wait** commands. This allows the user to force the repair of a specific file and to wait until repair of that file is complete.

To check the status of the self-healing mechanism, the `FSCTL_QUERY_REPAIR` control code or the **fsutil repair query** command can be used, as shown here:

```
C:\>fsutil repair query c:
Self healing state on c: is: 0x9
```

```
Values: 0x1 - Enable general repair.
        0x9 - Enable repair and warn about potential data loss.
        0x10 - Disable repair and bugcheck once on first corruption.
```

Online check-disk and fast repair

Rare cases in which disk-corruptions are not managed by the NTFS file system driver (through self-healing, Log file service, and so on) require the system to run the Windows Check Disk tool and to put the volume offline. There are a variety of unique causes for disk corruption: whether they are caused by media errors from the hard disk or transient memory errors, corruptions can happen in file system metadata. In large file servers, which have multiple terabytes of disk space, running a complete Check Disk can require days. Having a volume offline for so long in these kinds of scenarios is typically not acceptable.

Before Windows 8, NTFS implemented a simpler health model, where the file system volume was either healthy or not (through the dirty bit stored in the `$VOLUME_INFORMATION` attribute). In that model, the volume was taken offline for as long as necessary to fix the file system corruptions and bring the volume back to a healthy state. Downtime was directly proportional to the number of files in the volume. Windows 8, with the goal of reducing or avoiding the downtime caused by file system corruption, has redesigned the NTFS health model and disk check.

The new model introduces new components that cooperate to provide an online check-disk tool and to drastically reduce the downtime in case severe file-system corruption is detected. The NTFS file system driver is able to identify multiple types of corruption during normal system I/O. If a corruption is detected,

NTFS tries to self-heal it (see the previous paragraph). If it doesn't succeed, the NTFS file system driver writes a new *corruption record* to the \$Verify stream of the \Extend\RmMetadata\\$Repair file.

A corruption record is a common data structure that NTFS uses for describing metadata corruptions and is used both in-memory and on-disk. A corruption record is represented by a fixed-size header, which contains version information, flags, and uniquely represents the record type through a GUID, a variable-sized description for the type of corruption that occurred, and an optional context.

After the entry has been correctly added, NTFS emits an ETW event through its own event provider (named Microsoft-Windows-Ntfs-UBPM). This ETW event is consumed by the service control manager, which will start the Spot Verifier service (more details about triggered-start services are available in Chapter 10).

The Spot Verifier service (implemented in the Svsvc.dll library) verifies that the signaled corruption is not a false positive (some corruptions are intermittent due to memory issues and may not be a result of an actual corruption on disk). Entries in the \$Verify stream are removed while being verified by the Spot Verifier. If the corruption (described by the entry) is not a false positive, the Spot Verifier triggers the Proactive Scan Bit (P-bit) in the \$VOLUME_INFORMATION attribute of the volume, which will trigger an online scan of the file system. The online scan is executed by the Proactive Scanner, which is run as a maintenance task by the Windows task scheduler (the task is located in Microsoft\Windows\Chkdsk, as shown in Figure 11-66) when the time is appropriate.

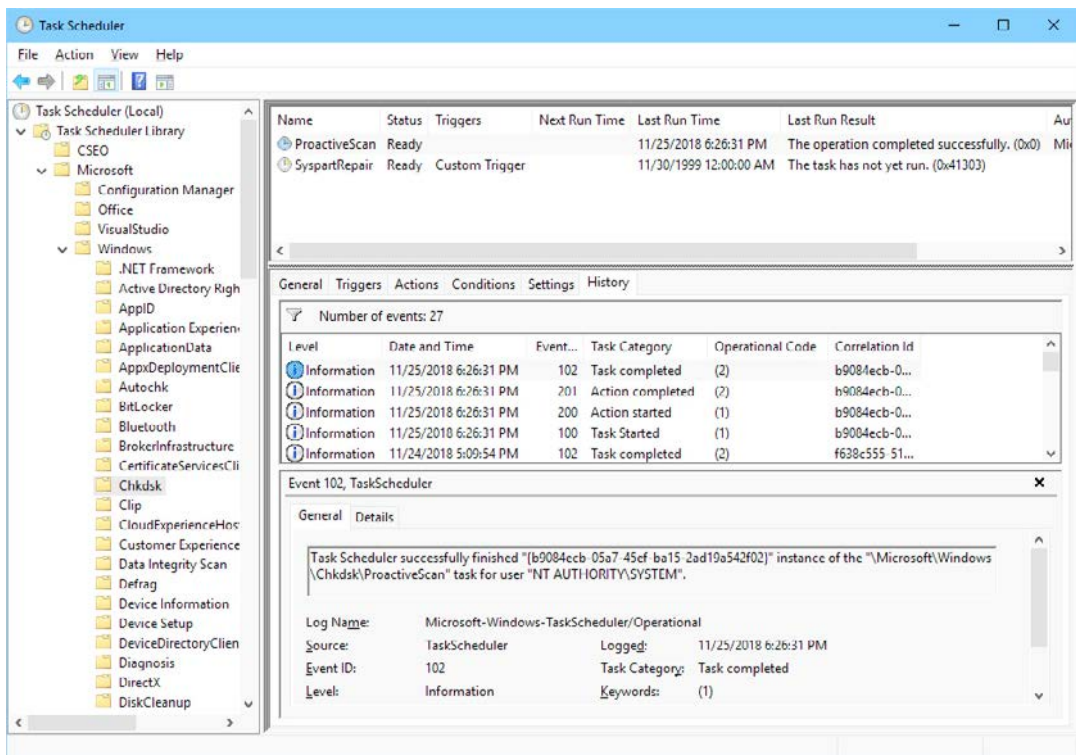

FIGURE 11-66 The Proactive Scan maintenance task.

The Proactive scanner is implemented in the `Untfs.dll` library, which is imported by the Windows Check Disk tool (`Chkdsk.exe`). When the Proactive Scanner runs, it takes a snapshot of the target volume through the Volume Shadow Copy service and runs a complete Check Disk on the shadow volume. The shadow volume is read-only; the check disk code detects this and, instead of directly fixing the errors, uses the self-healing feature of NTFS to try to automatically fix the corruption. If it fails, it sends a `FSTCTL_CORRUPTION_HANDLING` code to the file system driver, which in turn creates an entry in the `$Corrupt` stream of the `\$Extend\$RmMetadata\Repair` metadata file and sets the volume's dirty bit.

The dirty bit has a slightly different meaning compared to previous editions of Windows. The `$VOLUME_INFORMATION` attribute of the NTFS root namespace still contains the dirty bit, but also contains the P-bit, which is used to require a Proactive Scan, and the F-bit, which is used to require a full check disk due to the severity of a particular corruption. The dirty bit is set to 1 by the file system driver if the P-bit or the F-bit are enabled, or if the `$Corrupt` stream contains one or more corruption records.

If the corruption is still not resolved, at this stage there are no other possibilities to fix it when the volume is offline (this does not necessarily require an immediate volume unmounting). The Spot Fixer is a new component that is shared between the Check Disk and the Autocheck tool. The Spot Fixer consumes the records inserted in the `$Corrupt` stream by the Proactive scanner. At boot time, the Autocheck native application detects that the volume is dirty, but, instead of running a full check disk, it fixes only the corrupted entries located in the `$Corrupt` stream, an operation that requires only a few seconds. Figure 11-67 shows a summary of the different repair methodology implemented in the previously described components of the NTFS file system.

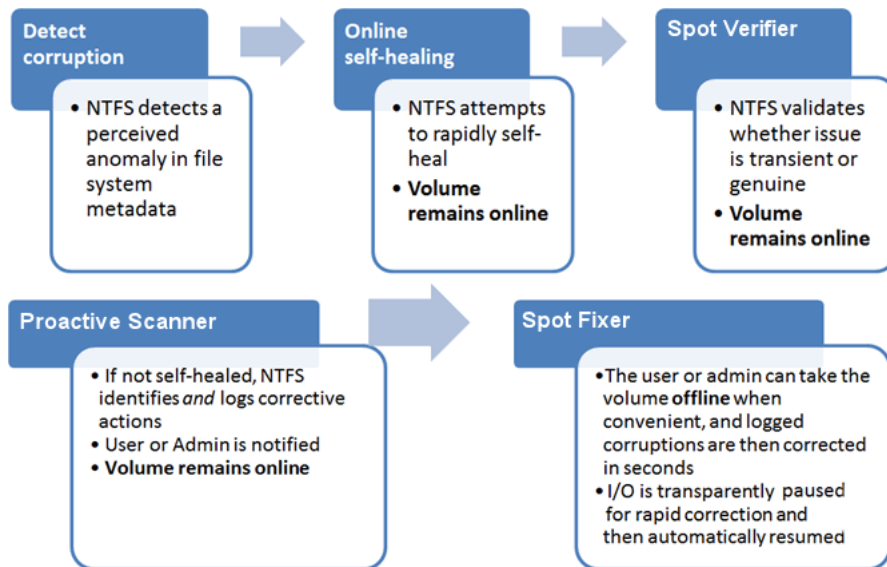

FIGURE 11-67 A scheme that describes the components that cooperate to provide online check disk and fast corruption repair for NTFS volumes.

A Proactive scan can be manually started for a volume through the `chkdsk /scan` command. In the same way, the Spot Fixer can be executed by the Check Disk tool using the `/spotfix` command-line argument.

EXPERIMENT: Testing the online disk check

You can test the online checkdisk by performing a simple experiment. Assuming that you would like to execute an online checkdisk on the D: volume, start by playing a large video stream from the D drive. In the meantime, open an administrative command prompt window and start an online checkdisk through the following command:

```
C:\>chkdsk d: /scan
The type of the file system is NTFS.
Volume label is DATA.

Stage 1: Examining basic file system structure ...
 4041984 file records processed.
File verification completed.
 3778 large file records processed.
 0 bad file records processed.
```

```
Stage 2: Examining file name linkage ...
Progress: 3454102 of 4056090 done; Stage: 85%; Total: 51%; ETA: 0:00:43 ..
```

You will find that the video stream won't be stopped and continues to play smoothly. In case the online checkdisk finds an error that it isn't able to correct while the volume is mounted, it will be inserted in the \$Corrupt stream of the \$Repair system file. To fix the errors, a volume dismount is needed, but the correction will be very fast. In that case, you could simply reboot the machine or manually execute the Spot Fixer through the command line:

```
C:\>chkdsk d: /spotfix
```

In case you choose to execute the Spot Fixer, you will find that the video stream will be interrupted, because the volume needs to be unmounted.

Encrypted file system

Windows includes a full-volume encryption feature called Windows BitLocker Drive Encryption. BitLocker encrypts and protects volumes from offline attacks, but once a system is booted, BitLocker's job is done. The Encrypting File System (EFS) protects individual files and directories from other authenticated users on a system. When choosing how to protect your data, it is not an either/or choice between BitLocker and EFS; each provides protection from specific—and nonoverlapping—threats. Together, BitLocker and EFS provide a “defense in depth” for the data on your system.

The paradigm used by EFS is to encrypt files and directories using symmetric encryption (a single key that is used for encrypting and decrypting the file). The symmetric encryption key is then encrypted using asymmetric encryption (one key for encryption—often referred to as the public key—and a different key for decryption—often referred to as the private key) for each user who is granted access to the file. The details and theory behind these encryption methods is beyond the scope of this book; however, a good primer is available at <https://docs.microsoft.com/en-us/windows/desktop/SecCrypto/cryptography-essentials>.

EFS works with the Windows Cryptography Next Generation (CNG) APIs, and thus may be configured to use any algorithm supported by (or added to) CNG. By default, EFS will use the Advanced Encryption Standard (AES) for symmetric encryption (256-bit key) and the Rivest-Shamir-Adleman (RSA) public key algorithm for asymmetric encryption (2,048-bit keys).

Users can encrypt files via Windows Explorer by opening a file's **Properties** dialog box, clicking **Advanced**, and then selecting the **Encrypt Contents To Secure Data** option, as shown in Figure 11-68. (A file may be encrypted or compressed, but not both.) Users can also encrypt files via a command-line utility named Cipher (%SystemRoot%\System32\Cipher.exe) or programmatically using Windows APIs such as *EncryptFile* and *AddUsersToEncryptedFile*.

Windows automatically encrypts files that reside in directories that are designated as encrypted directories. When a file is encrypted, EFS generates a random number for the file that EFS calls the file's *File Encryption Key* (FEK). EFS uses the FEK to encrypt the file's contents using symmetric encryption. EFS then encrypts the FEK using the user's asymmetric public key and stores the encrypted FEK in the \$EFS alternate data stream for the file. The source of the public key may be administratively specified to come from an assigned X.509 certificate or a smartcard or can be randomly generated (which would then be added to the user's certificate store, which can be viewed using the Certificate Manager (%SystemRoot%\System32\Certmgr.msc). After EFS completes these steps, the file is secure; other users can't decrypt the data without the file's decrypted FEK, and they can't decrypt the FEK without the user private key.

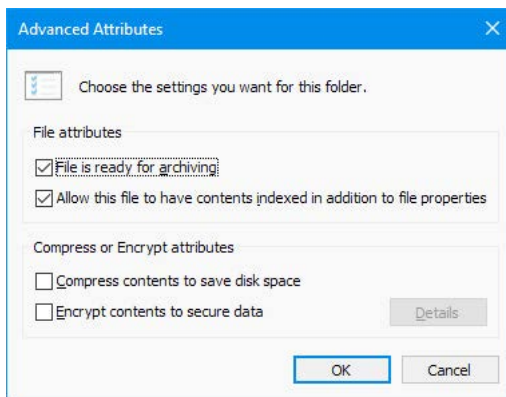

FIGURE 11-68 Encrypt files by using the Advanced Attributes dialog box.

Symmetric encryption algorithms are typically very fast, which makes them suitable for encrypting large amounts of data, such as file data. However, symmetric encryption algorithms have a weakness: You can bypass their security if you obtain the key. If multiple users want to share one encrypted file protected only using symmetric encryption, each user would require access to the file's FEK. Leaving the FEK unencrypted would obviously be a security problem, but encrypting the FEK once would require all the users to share the same FEK decryption key—another potential security problem.

Keeping the FEK secure is a difficult problem, which EFS addresses with the public key–based half of its encryption architecture. Encrypting a file's FEK for individual users who access the file lets multiple users share an encrypted file. EFS can encrypt a file's FEK with each user's public key and can store each user's encrypted FEK in the file's \$EFS data stream. Anyone can access a user's public key, but no one

can use a public key to decrypt the data that the public key encrypted. The only way users can decrypt a file is with their private key, which the operating system must access. A user's private key decrypts the user's encrypted copy of a file's FEK. Public key-based algorithms are usually slow, but EFS uses these algorithms only to encrypt FEKs. Splitting key management between a publicly available key and a private key makes key management a little easier than symmetric encryption algorithms do and solves the dilemma of keeping the FEK secure.

Several components work together to make EFS work, as the diagram of EFS architecture in Figure 11-69 shows. EFS support is merged into the NTFS driver. Whenever NTFS encounters an encrypted file, NTFS executes EFS functions that it contains. The EFS functions encrypt and decrypt file data as applications access encrypted files. Although EFS stores an FEK with a file's data, users' public keys encrypt the FEK. To encrypt or decrypt file data, EFS must decrypt the file's FEK with the aid of CNG key management services that reside in user mode.

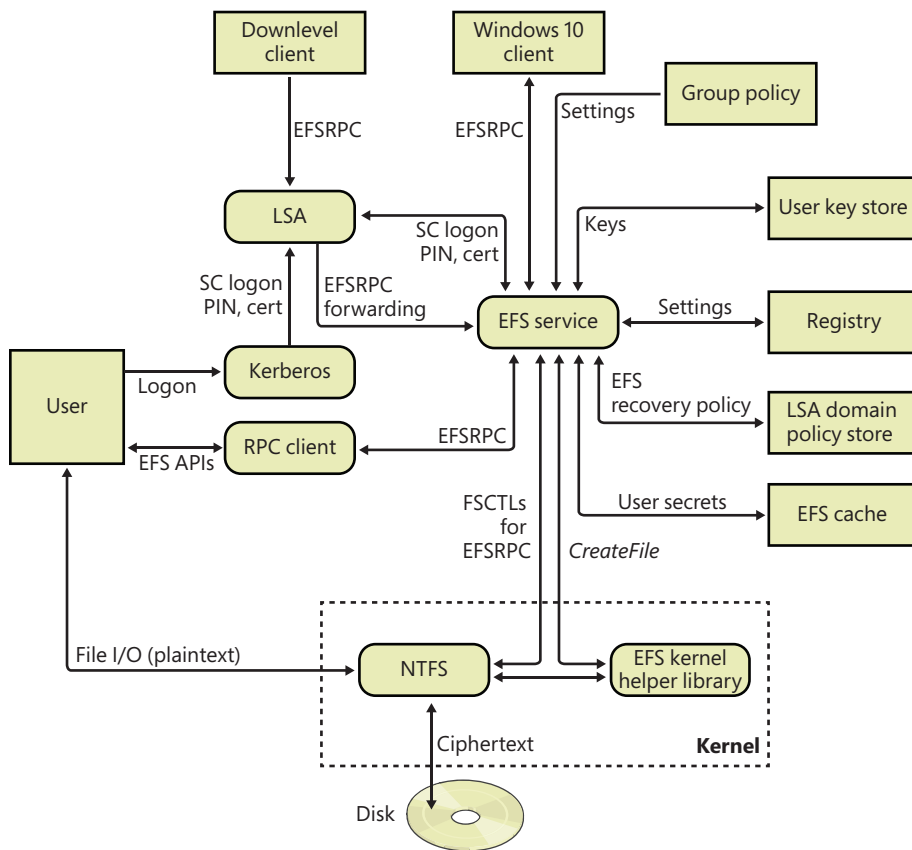

FIGURE 11-69 EFS architecture.

The Local Security Authority Subsystem (LSASS, %SystemRoot%\System32\lsass.exe) manages logon sessions but also hosts the EFS service (Efs.sys). For example, when EFS needs to decrypt a FEK to decrypt file data a user wants to access, NTFS sends a request to the EFS service inside LSASS.

Encrypting a file for the first time

The NTFS driver calls its EFS helper functions when it encounters an encrypted file. A file's attributes record that the file is encrypted in the same way that a file records that it's compressed (discussed earlier in this chapter). NTFS has specific interfaces for converting a file from nonencrypted to encrypted form, but user-mode components primarily drive the process. As described earlier, Windows lets you encrypt a file in two ways: by using the *cipher* command-line utility or by checking the **Encrypt Contents To Secure Data** check box in the **Advanced Attributes** dialog box for a file in Windows Explorer. Both Windows Explorer and the *cipher* command rely on the *EncryptFile* Windows API.

EFS stores only one block of information in an encrypted file, and that block contains an entry for each user sharing the file. These entries are called *key entries*, and EFS stores them in the data decryption field (DDF) portion of the file's EFS data. A collection of multiple key entries is called a *key ring* because, as mentioned earlier, EFS lets multiple users share encrypted files.

Figure 11-70 shows a file's EFS information format and key entry format. EFS stores enough information in the first part of a key entry to precisely describe a user's public key. This data includes the user's security ID (SID) (note that the SID is not guaranteed to be present), the container name in which the key is stored, the cryptographic provider name, and the asymmetric key pair certificate hash. Only the asymmetric key pair certificate hash is used by the decryption process. The second part of the key entry contains an encrypted version of the FEK. EFS uses the CNG to encrypt the FEK with the selected asymmetric encryption algorithm and the user's public key.

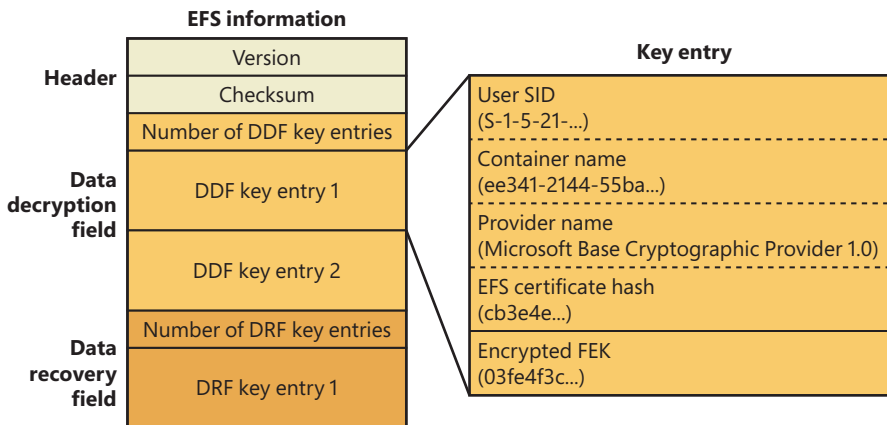

FIGURE 11-70 Format of EFS information and key entries.

EFS stores information about recovery key entries in a file's data recovery field (DRF). The format of DRF entries is identical to the format of DDF entries. The DRF's purpose is to let designated accounts, or recovery agents, decrypt a user's file when administrative authority must have access to the user's data. For example, suppose a company employee forgot his or her logon password. An administrator can reset the user's password, but without recovery agents, no one can recover the user's encrypted data.

Recovery agents are defined with the Encrypted Data Recovery Agents security policy of the local computer or domain. This policy is available from the Local Security Policy MMC snap-in, as shown in Figure 11-71. When you use the Add Recovery Agent Wizard (by right-clicking **Encrypting File System** and then clicking **Add Data Recovery Agent**), you can add recovery agents and specify which private/public key pairs (designated by their certificates) the recovery agents use for EFS recovery. Lsassrv (Local Security Authority service, which is covered in Chapter 7 of Part 1) interprets the recovery policy when it initializes and when it receives notification that the recovery policy has changed. EFS creates a DRF key entry for each recovery agent by using the cryptographic provider registered for EFS recovery.

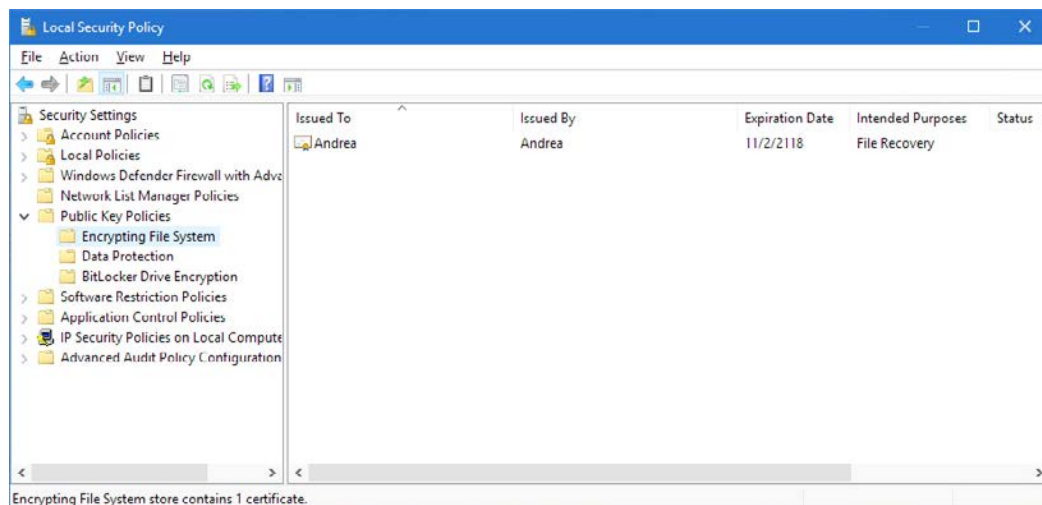

FIGURE 11-71 Encrypted Data Recovery Agents group policy.

A user can create their own Data Recovery Agent (DRA) certificate by using the **cipher /r** command. The generated private certificate file can be imported by the Recovery Agent Wizard and by the Certificates snap-in of the domain controller or the machine on which the administrator should be able to decrypt encrypted files.

As the final step in creating EFS information for a file, Lsassrv calculates a checksum for the DDF and DRF by using the MD5 hash facility of Base Cryptographic Provider 1.0. Lsassrv stores the checksum's result in the EFS information header. EFS references this checksum during decryption to ensure that the contents of a file's EFS information haven't become corrupted or been tampered with.

Encrypting file data

When a user encrypts an existing file, the following process occurs:

1. The EFS service opens the file for exclusive access.
2. All data streams in the file are copied to a plaintext temporary file in the system's temporary directory.
3. A FEK is randomly generated and used to encrypt the file by using AES-256.

4. A DDF is created to contain the FEK encrypted by using the user's public key. EFS automatically obtains the user's public key from the user's X.509 version 3 file encryption certificate.
5. If a recovery agent has been designated through Group Policy, a DRF is created to contain the FEK encrypted by using RSA and the recovery agent's public key.
6. EFS automatically obtains the recovery agent's public key for file recovery from the recovery agent's X.509 version 3 certificate, which is stored in the EFS recovery policy. If there are multiple recovery agents, a copy of the FEK is encrypted by using each agent's public key, and a DRF is created to store each encrypted FEK.



Note The file recovery property in the certificate is an example of an enhanced key usage (EKU) field. An EKU extension and extended property specify and limit the valid uses of a certificate. File Recovery is one of the EKU fields defined by Microsoft as part of the Microsoft public key infrastructure (PKI).

7. EFS writes the encrypted data, along with the DDF and the DRF, back to the file. Because symmetric encryption does not add additional data, file size increase is minimal after encryption. The metadata, consisting primarily of encrypted FEKs, is usually less than 1 KB. File size in bytes before and after encryption is normally reported to be the same.
8. The plaintext temporary file is deleted.

When a user saves a file to a folder that has been configured for encryption, the process is similar except that no temporary file is created.

The decryption process

When an application accesses an encrypted file, decryption proceeds as follows:

1. NTFS recognizes that the file is encrypted and sends a request to the EFS driver.
2. The EFS driver retrieves the DDF and passes it to the EFS service.
3. The EFS service retrieves the user's private key from the user's profile and uses it to decrypt the DDF and obtain the FEK.
4. The EFS service passes the FEK back to the EFS driver.
5. The EFS driver uses the FEK to decrypt sections of the file as needed for the application.



Note When an application opens a file, only those sections of the file that the application is using are decrypted because EFS uses cipher block chaining. The behavior is different if the user removes the encryption attribute from the file. In this case, the entire file is decrypted and rewritten as plaintext.

6. The EFS driver returns the decrypted data to NTFS, which then sends the data to the requesting application.

Backing up encrypted files

An important aspect of any file encryption facility's design is that file data is never available in un-encrypted form except to applications that access the file via the encryption facility. This restriction particularly affects backup utilities, in which archival media store files. EFS addresses this problem by providing a facility for backup utilities so that the utilities can back up and restore files in their encrypted states. Thus, backup utilities don't have to be able to decrypt file data, nor do they need to encrypt file data in their backup procedures.

Backup utilities use the EFS API functions *OpenEncryptedFileRaw*, *ReadEncryptedFileRaw*, *WriteEncryptedFileRaw*, and *CloseEncryptedFileRaw* in Windows to access a file's encrypted contents. After a backup utility opens a file for raw access during a backup operation, the utility calls *ReadEncryptedFileRaw* to obtain the file data. All the EFS backup utilities APIs work by issuing FSCTL to the NTFS file system. For example, the *ReadEncryptedFileRaw* API first reads the \$EFS stream by issuing a *FSCTL_ENCRYPTION_FSCTL_IO* control code to the NTFS driver and then reads all of the file's streams (including the \$DATA stream and optional alternate data streams); in case the stream is encrypted, the *ReadEncryptedFileRaw* API uses the *FSCTL_READ_RAW_ENCRYPTED* control code to request the encrypted stream data to the file system driver.

EXPERIMENT: Viewing EFS information

EFS has a handful of other API functions that applications can use to manipulate encrypted files. For example, applications use the *AddUsersToEncryptedFile* API function to give additional users access to an encrypted file and *RemoveUsersFromEncryptedFile* to revoke users' access to an encrypted file. Applications use the *QueryUsersOnEncryptedFile* function to obtain information about a file's associated DDF and DRF key fields. *QueryUsersOnEncryptedFile* returns the SID, certificate hash value, and display information that each DDF and DRF key field contains. The following output is from the EFSDump utility, from Sysinternals, when an encrypted file is specified as a command-line argument:

```
C:\Andrea>efsdump Test.txt
EFS Information Dumper v1.02
Copyright (C) 1999 Mark Russinovich
Systems Internals - http://www.sysinternals.com
```

```
C:\Andrea\Test.txt:
DDF Entries:
  WIN-46E4EFTBP6Q\Andrea:
    Andrea(Andrea@WIN-46E4EFTBP6Q)
  Unknown user:
    Tony(Tony@WIN-46E4EFTBP6Q)
DRF Entry:
  Unknown user:
    EFS Data Recovery
```

You can see that the file `Test.txt` has two DDF entries for the users Andrea and Tony and one DRF entry for the EFS Data Recovery agent, which is the only recovery agent currently registered on the system. You can use the `cipher` tool to add or remove users in the DDF entries of a file. For example, the command

```
cipher /adduser /user:Tony Test.txt
```

enables the user Tony to access the encrypted file `Test.txt` (adding an entry in the DDF of the file).

Copying encrypted files

When an encrypted file is copied, the system doesn't decrypt the file and re-encrypt it at its destination; it just copies the encrypted data and the EFS alternate data stream to the specified destination. However, if the destination does not support alternate data streams—if it is not an NTFS volume (such as a FAT volume) or is a network share (even if the network share is an NTFS volume)—the copy cannot proceed normally because the alternate data streams would be lost. If the copy is done with Explorer, a dialog box informs the user that the destination volume does not support encryption and asks the user whether the file should be copied to the destination unencrypted. If the user agrees, the file will be decrypted and copied to the specified destination. If the copy is done from a command prompt, the copy command will fail and return the error message “The specified file could not be encrypted.”

BitLocker encryption offload

The NTFS file system driver uses services provided by the Encrypting File System (EFS) to perform file encryption and decryption. These kernel-mode services, which communicate with the user-mode encrypting file service (`Efssvc.dll`), are provided to NTFS through callbacks. When a user or application encrypts a file for the first time, the EFS service sends a `FSCTL_SET_ENCRYPTION` control code to the NTFS driver. The NTFS file system driver uses the “write” EFS callback to perform in-memory encryption of the data located in the original file. The actual encryption process is performed by splitting the file content, which is usually processed in 2-MB blocks, in small 512-byte chunks. The EFS library uses the `BCryptEncrypt` API to actually encrypt the chunk. As previously mentioned, the encryption engine is provided by the Kernel CNG driver (`Cng.sys`), which supports the AES or 3DES algorithms used by EFS (along with many more). As EFS encrypts each 512-byte chunk (which is the smallest physical size of standard hard disk sectors), at every round it updates the IV (initialization vector, also known as *salt value*, which is a 128-bit number used to provide randomization to the encryption scheme), using the byte offset of the current block.

In Windows 10, encryption performance has increased thanks to BitLocker *encryption offload*. When BitLocker is enabled, the storage stack already includes a device created by the Full Volume Encryption Driver (`Fvevol.sys`), which, if the volume is encrypted, performs real-time encryption/decryption on physical disk sectors; otherwise, it simply passes through the I/O requests.

The NTFS driver can defer the encryption of a file by using IRP Extensions. IRP Extensions are provided by the I/O manager (more details about the I/O manager are available in Chapter 6 of Part 1) and are a way to store different types of additional information in an IRP. At file creation time, the EFS driver probes the device stack to check whether the BitLocker control device object (CDO) is present (by using the `IOCTL_FVE_GET_CDOPATH` control code), and, if so, it sets a flag in the SCB, indicating that the stream can support encryption offload.

Every time an encrypted file is read or written, or when a file is encrypted for the first time, the NTFS driver, based on the previously set flag, determines whether it needs to encrypt/decrypt each file block. In case encryption offload is enabled, NTFS skips the call to EFS; instead, it adds an IRP extension to the IRP that will be sent to the related volume device for performing the physical I/O. In the IRP extension, the NTFS file system driver stores the starting virtual byte offset of the block of the file that the storage driver is going to read or write, its size, and some flags. The NTFS driver finally emits the I/O to the related volume device by using the *IoCallDriver* API.

The volume manager will parse the IRP and send it to the correct storage driver. The BitLocker driver recognizes the IRP extension and encrypts the data that NTFS has sent down to the device stack, using its own routines, which operate on physical sectors. (Bitlocker, as a volume filter driver, doesn't implement the concept of files and directories.) Some storage drivers, such as the Logical Disk Manager driver (*VolmgrX.sys*, which provides dynamic disk support) are filter drivers that attach to the volume device objects. These drivers reside below the volume manager but above the BitLocker driver, and they can provide data redundancy, striping, or storage virtualization, characteristics which are usually implemented by splitting the original IRP into multiple secondary IRPs that will be emitted to different physical disk devices. In this case, the secondary I/Os, when intercepted by the BitLocker driver, will result in data encrypted by using a different salt value that would corrupt the file data.

IRP extensions support the concept of IRP propagation, which automatically modifies the file virtual byte offset stored in the IRP extension every time the original IRP is split. Normally, the EFS driver encrypts file blocks on 512-byte boundaries, and the IRP can't be split on an alignment less than a sector size. As a result, BitLocker can correctly encrypt and decrypt the data, ensuring that no corruption will happen.

Many of BitLocker driver's routines can't tolerate memory failures. However, since IRP extension is dynamically allocated from the nonpaged pool when the IRP is split, the allocation can fail. The I/O manager resolves this problem with the *IoAllocateIrpEx* routine. This routine can be used by kernel drivers for allocating IRPs (like the legacy *IoAllocateIrp*). But the new routine allocates an extra stack location and stores any IRP extensions in it. Drivers that request an IRP extension on IRPs allocated by the new API no longer need to allocate new memory from the nonpaged pool.



Note A storage driver can decide to split an IRP for different reasons—whether or not it needs to send multiple I/Os to multiple physical devices. The Volume Shadow Copy Driver (*Volsnap.sys*), for example, splits the I/O while it needs to read a file from a copy-on-write volume shadow copy, if the file resides in different sections: on the live volume and on the Shadow Copy's differential file (which resides in the System Volume Information hidden directory).

Online encryption support

When a file stream is encrypted or decrypted, it is exclusively locked by the NTFS file system driver. This means that no applications can access the file during the entire encryption or decryption process. For large files, this limitation can break the file's availability for many seconds—or even minutes. Clearly this is not acceptable for large file-server environments.

To resolve this, recent versions of Windows 10 introduced online encryption support. Through the right synchronization, the NTFS driver is able to perform file encryption and decryption without retaining exclusive file access. EFS enables online encryption only if the target encryption stream is a data stream (named or unnamed) and is nonresident. (Otherwise, a standard encryption process starts.) If both conditions are satisfied, the EFS service sends a `FSCTL_SET_ENCRYPTION` control code to the NTFS driver to set a flag that enables online encryption.

Online encryption is possible thanks to the "\$EfsBackup" attribute (of type `$LOGGED_UTILITY_STREAM`) and to the introduction of *range locks*, a new feature that allows the file system driver to lock (in an exclusive or shared mode) only a portion of a file. When online encryption is enabled, the `NtfsEncryptDecryptOnline` internal function starts the encryption and decryption process by creating the \$EfsBackup attribute (and its SCB) and by acquiring a shared lock on the first 2-MB range of the file. A shared lock means that multiple readers can still read from the file range, but other writers need to wait until the end of the encryption or decryption operation before they can write new data.

The NTFS driver allocates a 2-MB buffer from the nonpaged pool and reserves some clusters from the volume, which are needed to represent 2 MB of free space. (The total number of clusters depends on the volume cluster's size.) The online encryption function reads the original data from the physical disk and stores it in the allocated buffer. If BitLocker encryption offload is not enabled (described in the previous section), the buffer is encrypted using EFS services; otherwise, the BitLocker driver encrypts the data when the buffer is written to the previously reserved clusters.

At this stage, NTFS locks the entire file for a brief amount of time: only the time needed to remove the clusters containing the unencrypted data from the original stream's extent table, assign them to the \$EfsBackup non-resident attribute, and replace the removed range of the original stream's extent table with the new clusters that contain the newly encrypted data. Before releasing the exclusive lock, the NTFS driver calculates a new *high watermark* value and stores it both in the original file in-memory SCB and in the EFS payload of the \$EFS alternate data stream. NTFS then releases the exclusive lock. The clusters that contain the original data are first zeroed out; then, if there are no more blocks to process, they are eventually freed. Otherwise, the online encryption cycle restarts with the next 2-MB chunk.

The *high watermark* value stores the file offset that represents the boundary between encrypted and nonencrypted data. Any concurrent write beyond the watermark can occur in its original form; other concurrent writes before the watermark need to be encrypted before they can succeed. Writes to the current locked range are not allowed. Figure 11-72 shows an example of an ongoing online encryption for a 16-MB file. The first two blocks (2 MB in size) already have been encrypted; the *high watermark* value is set to 4 MB, dividing the file between its encrypted and non-encrypted data. A range lock is set on the 2-MB block that follows the *high watermark*. Applications can still read from that block, but they can't write any new data (in the latter case, they need to wait). The block's data is encrypted

and stored in reserved clusters. When exclusive file ownership is taken, the original block's clusters are remapped to the \$EfsBackup stream (by removing or splitting their entry in the original file's extent table and inserting a new entry in the \$EfsBackup attribute), and the new clusters are inserted in place of the previous ones. The *high watermark* value is increased, the file lock is released, and the online encryption process proceeds to the next stage starting at the 6-MB offset; the previous clusters located in the \$EfsBackup stream are concurrently zeroed-out and can be reused for new stages.

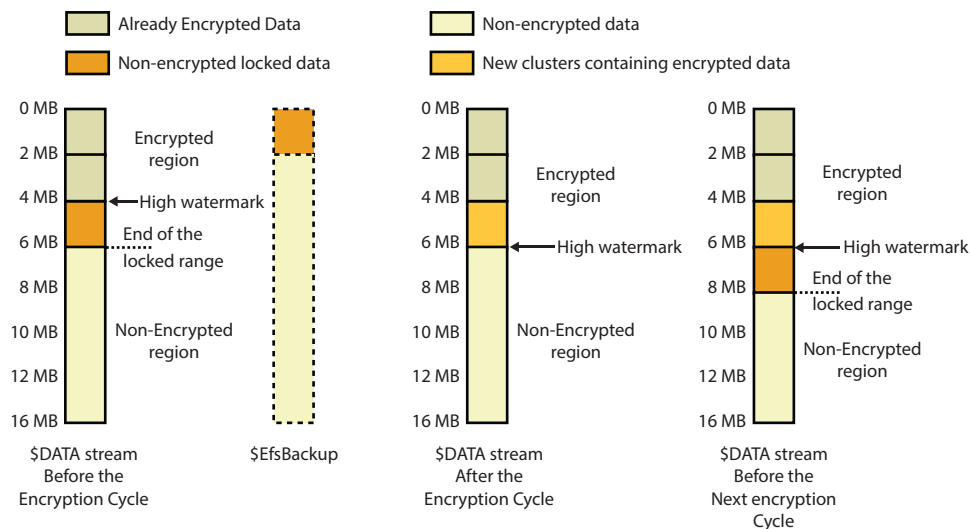

FIGURE 11-72 Example of an ongoing online encryption for a 16MB file.

The new implementation allows NTFS to encrypt or decrypt in place, getting rid of temporary files (see the previous “Encrypting file data” section for more details). More importantly, it allows NTFS to perform file encryption and decryption while other applications can still use and modify the target file stream (the time spent with the exclusive lock hold is small and not perceptible by the application that is attempting to use the file).

Direct Access (DAX) disks

Persistent memory is an evolution of solid-state disk technology: a new kind of nonvolatile storage medium that has RAM-like performance characteristics (low latency and high bandwidth), resides on the memory bus (DDR), and can be used like a standard disk device.

Direct Access Disks (DAX) is the term used by the Windows operating system to refer to such persistent memory technology (another common term used is *storage class memory*, abbreviated as SCM). A *nonvolatile dual in-line memory module* (NVDIMM), shown in Figure 11-73, is an example of this new type of storage. NVDIMM is a type of memory that retains its contents even when electrical power is removed. “Dual in-line” identifies the memory as using DIMM packaging. At the time of writing, there are three different types of NVDIMMs: NVDIMM-F contains only flash storage; NVDIMM-N, the most common, is

produced by combining flash storage and traditional DRAM chips on the same module; and NVDIMM-P has persistent DRAM chips, which do not lose data in event of power failure.

One of the main characteristics of DAX, which is key to its fast performance, is the support of *zero-copy access* to persistent memory. This means that many components, like the file system driver and memory manager, need to be updated to support DAX, which is a disruptive technology.

Windows Server 2016 was the first Windows operating system to supports DAX: the new storage model provides compatibility with most existing applications, which can run on DAX disks without any modification. For fastest performance, files and directories on a DAX volume need to be mapped in memory using memory-mapped APIs, and the volume needs to be formatted in a special DAX mode. At the time of this writing, only NTFS supports DAX volumes.

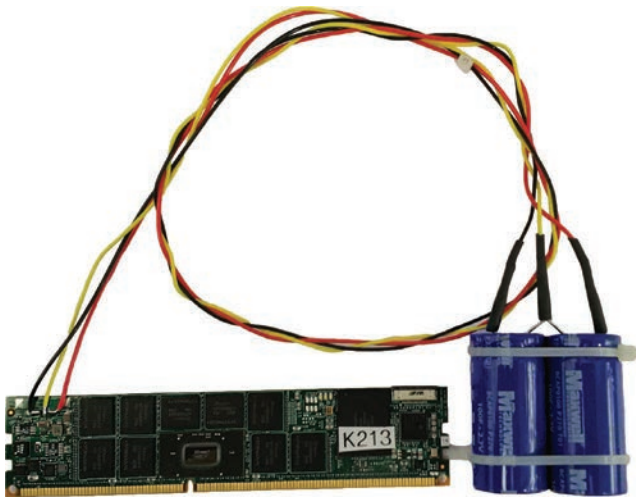

FIGURE 11-73 An NVDIMM, which has DRAM and Flash chips. An attached battery or on-board supercapacitors are needed for maintaining the data in the DRAM chips.

The following sections describe the way in which direct access disks operate and detail the architecture of the new driver model and the modification on the main components responsible for DAX volume support: the NTFS driver, memory manager, cache manager, and I/O manager. Additionally, inbox and third-party file system filter drivers (including mini filters) must also be individually updated to take full advantage of DAX.

DAX driver model

To support DAX volumes, Windows needed to introduce a brand-new storage driver model. The SCM Bus Driver (`Scmbus.sys`) is a new bus driver that enumerates physical and logical persistent memory (PM) devices on the system, which are attached to its memory bus (the enumeration is performed thanks to the *NFIT* ACPI table). The bus driver, which is not considered part of the I/O path, is a *primary* bus driver managed by the ACPI enumerator, which is provided by the HAL (hardware abstraction layer) through the hardware database registry key (`HKLM\SYSTEM\CurrentControlSet\Enum\ACPI`). More details about Plug & Play Device enumeration are available in Chapter 6 of Part 1.

Figure 11-74 shows the architecture of the SCM storage driver model. The SCM bus driver creates two different types of device objects:

- Physical device objects (PDOs) represent physical PM devices. A NVDIMM device is usually composed of one or multiple interleaved NVDIMM-N modules. In the former case, the SCM bus driver creates only one physical device object representing the NVDIMM unit. In the latter case, it creates two distinct devices that represent each NVDIMM-N module. All the physical devices are managed by the miniport driver, `Nvdim.sys`, which controls a physical NVDIMM and is responsible for monitoring its health.
- Functional device objects (FDOs) represent single DAX disks, which are managed by the persistent memory driver, `Pmem.sys`. The driver controls any byte-addressable interleave sets and is responsible for all I/O directed to a DAX volume. The persistent memory driver is the class driver for each DAX disk. (It replaces `Disk.sys` in the classical storage stack.)

Both the SCM bus driver and the NVDIMM miniport driver expose some interfaces for communication with the PM class driver. Those interfaces are exposed through an `IRP_MJ_PNP` major function by using the `IRP_MN_QUERY_INTERFACE` request. When the request is received, the SCM bus driver knows that it should expose its communication interface because callers specify the {8de064ff-b630-42e4-ea88-6f24c8641175} interface GUID. Similarly, the persistent memory driver requires communication interface to the NVDIMM devices through the {0079c21b-917e-405e-cea9-0732b5bbcebd} GUID.

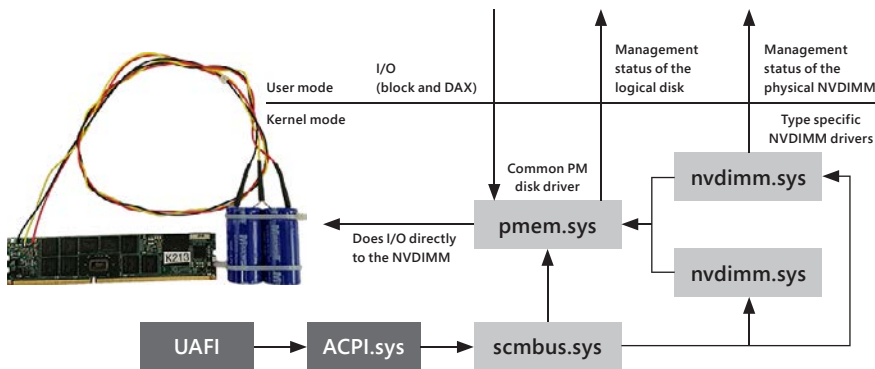

FIGURE 11-74 The SCM Storage driver model.

The new storage driver model implements a clear separation of responsibilities: The PM class driver manages logical disk functionality (open, close, read, write, memory mapping, and so on), whereas NVDIMM drivers manage the physical device and its health. It will be easy in the future to add support for new types of NVDIMM by just updating the `Nvdim.sys` driver. (`Pmem.sys` doesn't need to change.)

DAX volumes

The DAX storage driver model introduces a new kind of volume: the DAX volumes. When a user first formats a partition through the Format tool, she can specify the **/DAX** argument to the command line. If the underlying medium is a DAX disk, and it's partitioned using the GPT scheme, before creating the basic disk data structure needed for the NTFS file system, the tool writes the `GPT_BASIC_DATA_ATTRIBUTE_DAX`

flag in the target volume GPT partition entry (which corresponds to bit number 58). A good reference for the GUID partition table is available at https://en.wikipedia.org/wiki/GUID_Partition_Table.

When the NTFS driver then mounts the volume, it recognizes the flag and sends a *STORAGE_QUERY_PROPERTY* control code to the underlying storage driver. The IOCTL is recognized by the SCM bus driver, which responds to the file system driver with another flag specifying that the underlying disk is a DAX disk. Only the SCM bus driver can set the flag. Once the two conditions are verified, and as long as DAX support is not disabled through the *HKLM\System\CurrentControlSet\Control\FileSystem\NtfsEnableDirectAccess* registry value, NTFS enables DAX volume support.

DAX volumes are different from the standard volumes mainly because they support zero-copy access to the persistent memory. Memory-mapped files provide applications with direct access to the underlying hardware disk sectors (through a mapped view), meaning that no intermediary components will intercept any I/O. This characteristic provides extreme performance (but as mentioned earlier, can impact file system filter drivers, including minifilters).

When an application creates a memory-mapped section backed by a file that resides on a DAX volume, the memory manager asks the file system whether the section should be created in DAX mode, which is true only if the volume has been formatted in DAX mode, too. When the file is later mapped through the *MapViewOfFile* API, the memory manager asks the file system for the physical memory range of a given range of the file. The file system driver translates the requested file range in one or more volume relative extents (sector offset and length) and asks the PM disk class driver to translate the volume extents into physical memory ranges. The memory manager, after receiving the physical memory ranges, updates the target process page tables for the section to map directly to persistent storage. This is a truly zero-copy access to storage: an application has direct access to the persistent memory. No paging reads or paging writes will be generated. This is important; the cache manager is not involved in this case. We examine the implications of this later in the chapter.

Applications can recognize DAX volumes by using the *GetVolumeInformation* API. If the returned flags include *FILE_DAX_VOLUME*, the volume is formatted with a DAX-compatible file system (only NTFS at the time of this writing). In the same way, an application can identify whether a file resides on a DAX disk by using the *GetVolumeInformationByHandle* API.

Cached and noncached I/O in DAX volumes

Even though memory-mapped I/O for DAX volumes provide zero-copy access to the underlying storage, DAX volumes still support I/O through standard means (via classic *ReadFile* and *WriteFile* APIs). As described at the beginning of the chapter, Windows supports two kinds of regular I/O: cached and noncached. Both types have significant differences when issued to DAX volumes.

Cached I/O still requires interaction from the cache manager, which, while creating a shared cache map for the file, requires the memory manager to create a section object that directly maps to the PM hardware. NTFS is able to communicate to the cache manager that the target file is in DAX-mode through the new *CcInitializeCacheMapEx* routine. The cache manager will then copy data from the user buffer to persistent memory: cached I/O has therefore one-copy access to persistent storage. Note that cached I/O is still coherent with other memory-mapped I/O (the cache manager uses the same section);

as in the memory-mapped I/O case, there are still no paging reads or paging writes, so the lazy writer thread and intelligent read-ahead are not enabled.

One implication of the direct-mapping is that the cache manager directly writes to the DAX disk as soon as the *NtWriteFile* function completes. This means that cached I/O is essentially noncached. For this reason, noncached I/O requests are directly converted by the file system to cached I/O such that the cache manager still copies directly between the user's buffer and persistent memory. This kind of I/O is still coherent with cached and memory-mapped I/O.

NTFS continues to use standard I/O while processing updates to its metadata files. DAX mode I/O for each file is decided at stream creation time by setting a flag in the stream control block. If a file is a system metadata file, the attribute is never set, so the cache manager, when mapping such a file, creates a standard non-DAX file-backed section, which will use the standard storage stack for performing paging read or write I/Os. (Ultimately, each I/O is processed by the Pmem driver just like for block volumes, using the sector atomicity algorithm. See the "Block volumes" section for more details.) This behavior is needed for maintaining compatibility with write-ahead logging. Metadata must not be persisted to disk before the corresponding log is flushed. So, if a metadata file were DAX mapped, that write-ahead logging requirement would be broken.

Effects on file system functionality

The absence of regular paging I/O and the application's ability to directly access persistent memory eliminate traditional hook points that the file systems and related filters use to implement various features. Multiple functionality cannot be supported on DAX-enabled volumes, like file encryption, compressed and sparse files, snapshots, and USN journal support.

In DAX mode, the file system no longer knows when a writable memory-mapped file is modified. When the memory section is first created, the NTFS file system driver updates the file's modification and access times and marks the file as modified in the USN change journal. At the same time, it signals a directory change notification. DAX volumes are no longer compatible with any kind of legacy filter drivers and have a big impact on minifilters (filter manager clients). Components like BitLocker and the volume shadow copy driver (Volsnap.sys) don't work with DAX volumes and are removed from the device stack. Because a minifilter no longer knows if a file has been modified, an antimalware file access scanner, such as one described earlier, can no longer know if it should scan a file for viruses. It needs to assume, on any handle close, that modification may have occurred. In turn, this significantly harms performance, so minifilters must manually opt-in to support DAX volumes.

Mapping of executable images

When the Windows loader maps an executable image into memory, it uses memory-mapping services provided by the memory manager. The loader creates a memory-mapped image section by supplying the *SEC_IMAGE* flag to the *NtCreateSection* API. The flag specifies to the loader to map the section as an image, applying all the necessary fixups. In DAX mode this mustn't be allowed to happen; otherwise, all the relocations and fixups will be applied to the original image file on the PM disk. To correctly deal

with this problem, the memory manager applies the following strategies while mapping an executable image stored in a DAX mode volume:

- If there is already a control area that represents a data section for the binary file (meaning that an application has opened the image for reading binary data), the memory manager creates an empty memory-backed image section and copies the data from the existing data section to the newly created image section; then it applies the necessary fixups.
- If there are no data sections for the file, the memory manager creates a regular non-DAX image section, which creates standard invalid prototype PTEs (see Chapter 5 of Part 1 for more details). In this case, the memory manager uses the standard read and write routines of the Pmem driver to bring data in memory when a page fault for an invalid access on an address that belongs to the image-backed section happens.

At the time of this writing, Windows 10 does not support execution in-place, meaning that the loader is not able to directly execute an image from DAX storage. This is not a problem, though, because DAX mode volumes have been originally designed to store data in a very performant way. Execution in-place for DAX volumes will be supported in future releases of Windows.

EXPERIMENT: Witnessing DAX I/O with Process Monitor

You can witness DAX I/Os using Process Monitor from SysInternals and the FsTool.exe application, which is available in this book's downloadable resources. When an application reads or writes from a memory-mapped file that resides on a DAX-mode volume, the system does not generate any paging I/O, so nothing is visible to the NTFS driver or to the minifilters that are attached above or below it. To witness the described behavior, just open Process Monitor, and, assuming that you have two different volumes mounted as the P: and Q: drives, set the filters in a similar way as illustrated in the following figure (the Q: drive is the DAX-mode volume):

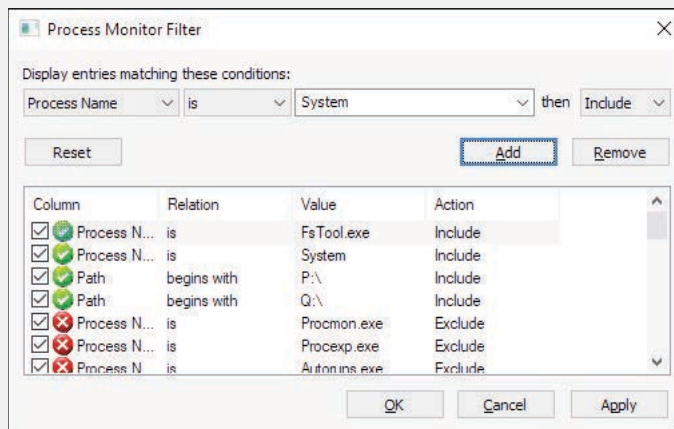

For generating I/O on DAX-mode volumes, you need to simulate a DAX copy using the FsTool application. The following example copies an ISO image located in the P: DAX block-mode volume (even a standard volume created on the top of a regular disk is fine for the experiment) to the DAX-mode “Q:” drive:

```
P:\>fstool.exe /daxcopy p:\Big_image.iso q:\test.iso
NTFS / ReFS Tool v0.1
Copyright (C) 2018 Andrea Allievi (Aal186)
```

Starting DAX copy...

```
Source file path: p:\Big_image.iso.
Target file path: q:\test.iso.
Source Volume: p:\ - File system: NTFS - Is DAX Volume: False.
Target Volume: q:\ - File system: NTFS - Is DAX Volume: True.
```

Source file size: 4.34 GB

Performing file copy... Success!

```
Total execution time: 8 Sec.
Copy Speed: 489.67 MB/Sec
```

Press any key to exit...

Process Monitor has captured a trace of the DAX copy operation that confirms the expected results:

Time ...	Process Name	PID	Operation	Path	Result	Detail
3:12:4...	FsTool.exe	8120	SetEndOfFileInformationFile	Q:\test.iso	SIUCCESS	EndOfFile: 4,556,566,528
3:12:4...	FsTool.exe	8120	File System Control	Q:\test.iso	SIUCCESS	Control: 0x9039b (Device:0x9 Function:230 Method: 3)
3:12:4...	FsTool.exe	8120	CreateFileMapping	Q:\test.iso	SIUCCESS	SyncType: SyncTypeOther
3:12:4...	FsTool.exe	8120	File System Control	Q:\test.iso	SIUCCESS	Control: 0x9039b (Device:0x9 Function:230 Method: 3)
3:12:4...	FsTool.exe	8120	File System Control	Q:\test.iso	SIUCCESS	Control: 0x9039b (Device:0x9 Function:230 Method: 3)
3:12:4...	FsTool.exe	8120	File System Control	Q:\test.iso	SIUCCESS	Control: 0x9039b (Device:0x9 Function:230 Method: 3)
3:12:4...	System	4	WriteFile	Q:\	SIUCCESS	Offset: 0, Length: 4,096, I/O Flags: Non-cached, Paging I/O, Synchronous F
3:12:4...	FsTool.exe	8120	File System Control	Q:\test.iso	SIUCCESS	Control: 0x9039b (Device:0x9 Function:230 Method: 3)
3:12:4...	FsTool.exe	8120	File System Control	Q:\test.iso	SIUCCESS	Control: 0x9039b (Device:0x9 Function:230 Method: 3)
3:12:4...	FsTool.exe	8120	ReadFile	P:\Big_image.iso	SIUCCESS	Offset: 0, Length: 32,768, I/O Flags: Non-cached, Paging I/O, Synchronous
3:12:4...	FsTool.exe	8120	ReadFile	P:\Big_image.iso	SIUCCESS	Offset: 32,768, Length: 32,768, I/O Flags: Non-cached, Paging I/O, Synchr
3:12:4...	FsTool.exe	8120	ReadFile	P:\Big_image.iso	SIUCCESS	Offset: 65,536, Length: 65,536, I/O Flags: Non-cached, Paging I/O, Synchr
3:12:4...	FsTool.exe	8120	ReadFile	P:\Big_image.iso	SIUCCESS	Offset: 131,072, Length: 131,072, I/O Flags: Non-cached, Paging I/O, Synchr
3:12:4...	FsTool.exe	8120	ReadFile	P:\Big_image.iso	SIUCCESS	Offset: 262,144, Length: 262,144, I/O Flags: Non-cached, Paging I/O, Synchr
3:12:4...	FsTool.exe	8120	ReadFile	P:\Big_image.iso	SIUCCESS	Offset: 524,288, Length: 524,288, I/O Flags: Non-cached, Paging I/O, Synchr
3:12:4...	FsTool.exe	8120	ReadFile	P:\Big_image.iso	SIUCCESS	Offset: 1,048,576, Length: 1,048,576, I/O Flags: Non-cached, Paging I/O, S
3:12:4...	FsTool.exe	8120	ReadFile	P:\Big_image.iso	SIUCCESS	Offset: 2,097,152, Length: 1,048,576, I/O Flags: Non-cached, Paging I/O, S
3:12:4...	FsTool.exe	8120	ReadFile	P:\Big_image.iso	SIUCCESS	Offset: 3,145,728, Length: 1,048,576, I/O Flags: Non-cached, Paging I/O, S
3:12:4...	FsTool.exe	8120	ReadFile	P:\Big_image.iso	SIUCCESS	Offset: 4,194,304, Length: 1,048,576, I/O Flags: Non-cached, Paging I/O, S
3:12:4...	FsTool.exe	8120	ReadFile	P:\Big_image.iso	SIUCCESS	Offset: 5,242,880, Length: 1,048,576, I/O Flags: Non-cached, Paging I/O, S
3:12:4...	FsTool.exe	8120	ReadFile	P:\Big_image.iso	SIUCCESS	Offset: 6,291,456, Length: 1,048,576, I/O Flags: Non-cached, Paging I/O, S

From the trace above, you can see that on the target file (Q:\test.iso), only the *CreateFileMapping* operation was intercepted: no *WriteFile* events are visible. While the copy was proceeding, only paging I/O on the source file was detected by Process Monitor. These paging I/Os were generated by the memory manager, which needed to read the data back from the source volume as the application was generating page faults while accessing the memory-mapped file.

To see the differences between memory-mapped I/O and standard cached I/O, you need to copy again the file using a standard file copy operation. To see paging I/O on the source file data, make sure to restart your system; otherwise, the original data remains in the cache:

```
P:\>fstool.exe /copy p:\Big_image.iso q:\test.iso
NTFS / ReFS Tool v0.1
Copyright (C) 2018 Andrea Allievi (AaL186)
```

Copying "Big_image.iso" to "test.iso" file... Success.

Total File-Copy execution time: 13 Sec - Transfer Rate: 313.71 MB/s.
Press any key to exit...

If you compare the trace acquired by Process Monitor with the previous one, you can confirm that cached I/O is a one-copy operation. The cache manager still copies chunks of memory between the application-provided buffer and the system cache, which is mapped directly on the DAX disk. This is confirmed by the fact that again, no paging I/O is highlighted on the target file.

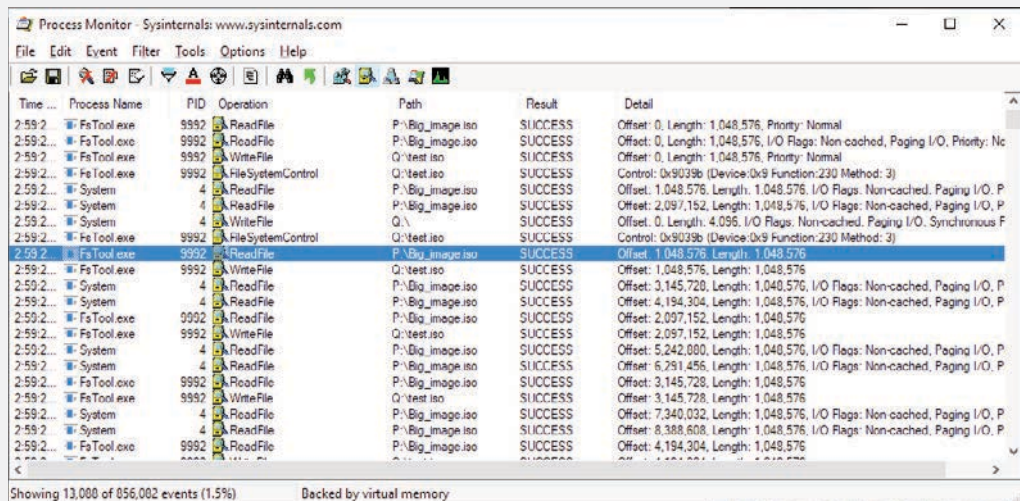

As a last experiment, you can try to start a DAX copy between two files that reside on the same DAX-mode volume or that reside on two different DAX-mode volumes:

```
P:\>fstool /daxcopy q:\test.iso q:\test_copy_2.iso
TFS / ReFS Tool v0.1
Copyright (C) 2018 Andrea Allievi (AaL186)
```

Starting DAX copy...

```
Source file path: q:\test.iso.
Target file path: q:\test_copy_2.iso.
Source Volume: q:\ - File system: NTFS - Is DAX Volume: True.
Target Volume: q:\ - File system: NTFS - Is DAX Volume: True.
```

Great! Both the source and the destination reside on a DAX volume.
Performing a full System Speed Copy!

Source file size: 4.34 GB

Performing file copy... Success!
Total execution time: 8 Sec.
Copy Speed: 501.60 MB/Sec

Press any key to exit...

The trace collected in the last experiment demonstrates that memory-mapped I/O on DAX volumes doesn't generate any paging I/O. No *WriteFile* or *ReadFile* events are visible on either the source or the target file:

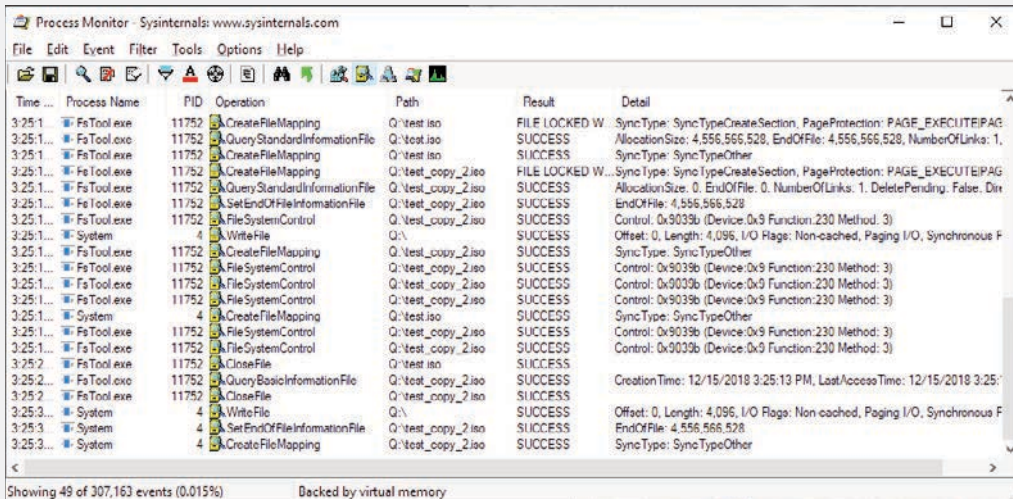

Time ...	Process Name	PID	Operation	Path	Result	Detail
3:25:1	Fa Tool.exe	11752	CreateFileMapping	Q:\test_iso	FILE LOCKED W...	SyncType: SyncTypeCreateSection, PageProtection: PAGE_EXECUTE/PAG...
3:25:1...	Fa Tool.exe	11752	QueryStandardInformationFile	Q:\test_iso	SUCCESS	AllocationSize: 4,556,566,528, EndOfFile: 4,556,566,528, NumberOfLinks: 1,
3:25:1...	Fa Tool.exe	11752	CreateFileMapping	Q:\test_iso	SUCCESS	SyncType: SyncTypeOther
3:25:1...	Fa Tool.exe	11752	CreateFileMapping	Q:\test_copy_2_iso	FILE LOCKED W...	SyncType: SyncTypeCreateSection, PageProtection: PAGE_EXECUTE/PAG...
3:25:1...	Fa Tool.exe	11752	QueryStandardInformationFile	Q:\test_copy_2_iso	SUCCESS	AllocationSize: 0, EndOfFile: 0, NumberOfLinks: 1, DeletePending: False, Dir...
3:25:1...	Fa Tool.exe	11752	SetEndOfFileInformationFile	Q:\test_copy_2_iso	SUCCESS	EndOfFile: 4,556,566,528
3:25:1...	Fa Tool.exe	11752	FileSystemControl	Q:\test_copy_2_iso	SUCCESS	Control: 0x9039b (Device:0x9 Function:230 Method: 3)
3:25:1...	System	4	WriteFile	Q:\	SUCCESS	Offset: 0, Length: 4,096, I/O Flags: Non-cached, Paging I/O, Synchronous F...
3:25:1...	Fa Tool.exe	11752	CreateFileMapping	Q:\test_copy_2_iso	SUCCESS	SyncType: SyncTypeOther
3:25:1...	Fa Tool.exe	11752	FileSystemControl	Q:\test_copy_2_iso	SUCCESS	Control: 0x9039b (Device:0x9 Function:230 Method: 3)
3:25:1...	Fa Tool.exe	11752	FileSystemControl	Q:\test_copy_2_iso	SUCCESS	Control: 0x9039b (Device:0x9 Function:230 Method: 3)
3:25:1...	Fa Tool.exe	11752	FileSystemControl	Q:\test_copy_2_iso	SUCCESS	Control: 0x9039b (Device:0x9 Function:230 Method: 3)
3:25:1...	System	4	CreateFileMapping	Q:\test_iso	SUCCESS	SyncType: SyncTypeOther
3:25:1...	Fa Tool.exe	11752	FileSystemControl	Q:\test_copy_2_iso	SUCCESS	Control: 0x9039b (Device:0x9 Function:230 Method: 3)
3:25:1...	Fa Tool.exe	11752	FileSystemControl	Q:\test_copy_2_iso	SUCCESS	Control: 0x9039b (Device:0x9 Function:230 Method: 3)
3:25:2	Fa Tool.exe	11752	CloseFile	Q:\test_iso	SUCCESS	CreationTime: 12/15/2018 3:25:13 PM, LastAccessTime: 12/15/2018 3:25:...
3:25:2...	Fa Tool.exe	11752	QueryBasicInformationFile	Q:\test_copy_2_iso	SUCCESS	EndOfFile: 4,556,566,528
3:25:2...	Fa Tool.exe	11752	CloseFile	Q:\test_copy_2_iso	SUCCESS	
3:25:3...	System	4	WriteFile	Q:\	SUCCESS	Offset: 0, Length: 4,096, I/O Flags: Non-cached, Paging I/O, Synchronous F...
3:25:3...	System	4	SetEndOfFileInformationFile	Q:\test_copy_2_iso	SUCCESS	EndOfFile: 4,556,566,528
3:25:3...	System	4	CreateFileMapping	Q:\test_copy_2_iso	SUCCESS	SyncType: SyncTypeOther

Block volumes

Not all the limitations brought on by DAX volumes are acceptable in certain scenarios. Windows provides backward compatibility for PM hardware through block-mode volumes, which are managed by the entire legacy I/O stack as regular volumes used by rotating and SSD disk. Block volumes maintain existing storage semantics: all I/O operations traverse the storage stack on the way to the PM disk class driver. (There are no miniport drivers, though, because they're not needed.) They're fully compatible with all existing applications, legacy filters, and minifilter drivers.

Persistent memory storage is able to perform I/O at byte granularity. More accurately, I/O is performed at cache line granularity, which depends on the architecture but is usually 64 bytes. However, block mode volumes are exposed as standard volumes, which perform I/O at sector granularity (512 bytes or 4 Kbytes). If a write is in progress on a DAX volume, and suddenly the drive experiences a power failure, the block of data (sector) contains a mix of old and new data. Applications are not prepared to handle such a scenario. In block mode, the sector atomicity is guaranteed by the PM disk class driver, which implements the Block Translation Table (BTT) algorithm.

The BTT, an algorithm developed by Intel, splits available disk space into chunks of up to 512 GB, called *arenas*. For each arena, the algorithm maintains a BTT, a simple indirection/lookup that maps an LBA to an internal block belonging to the arena. For each 32-bit entry in the map, the algorithm uses the two most significant bits (MSB) to store the status of the block (three states: valid, zeroed, and error). Although the table maintains the status of each LBA, the BTT algorithm provides sector atomicity by providing a *flog* area, which contains an array of *nfree* blocks.

An *nfree* block contains all the data that the algorithm needs to provide sector atomicity. There are 256 *nfree* entries in the array; an *nfree* entry is 32 bytes in size, so the *flog* area occupies 8 KB. Each *nfree* is used by one CPU, so the number of *nfree*s describes the number of concurrent atomic I/Os an arena can process concurrently. Figure 11-75 shows the layout of a DAX disk formatted in block mode. The data structures used for the BTT algorithm are not visible to the file system driver. The BTT algorithm eliminates possible subsector torn writes and, as described previously, is needed even on DAX-formatted volumes in order to support file system metadata writes.

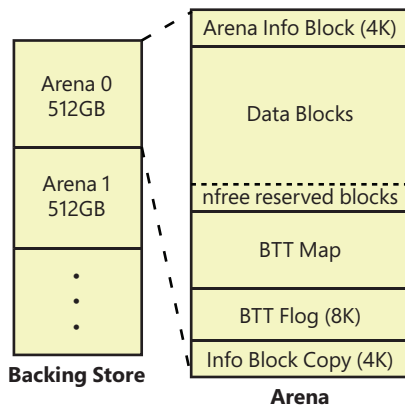

FIGURE 11-75 Layout of a DAX disk that supports sector atomicity (BTT algorithm).

Block mode volumes do not have the `GPT_BASIC_DATA_ATTRIBUTE_DAX` flag in their partition entry. NTFS behaves just like with normal volumes by relying on the cache manager to perform cached I/O, and by processing non-cached I/O through the PM disk class driver. The Pmem driver exposes read and write functions, which performs a direct memory access (DMA) transfer by building a memory descriptor list (MDL) for both the user buffer and device physical block address (MDLs are described in more detail in Chapter 5 of Part 1). The BTT algorithm provides sector atomicity. Figure 11-76 shows the I/O stack of a traditional volume, a DAX volume, and a block volume.

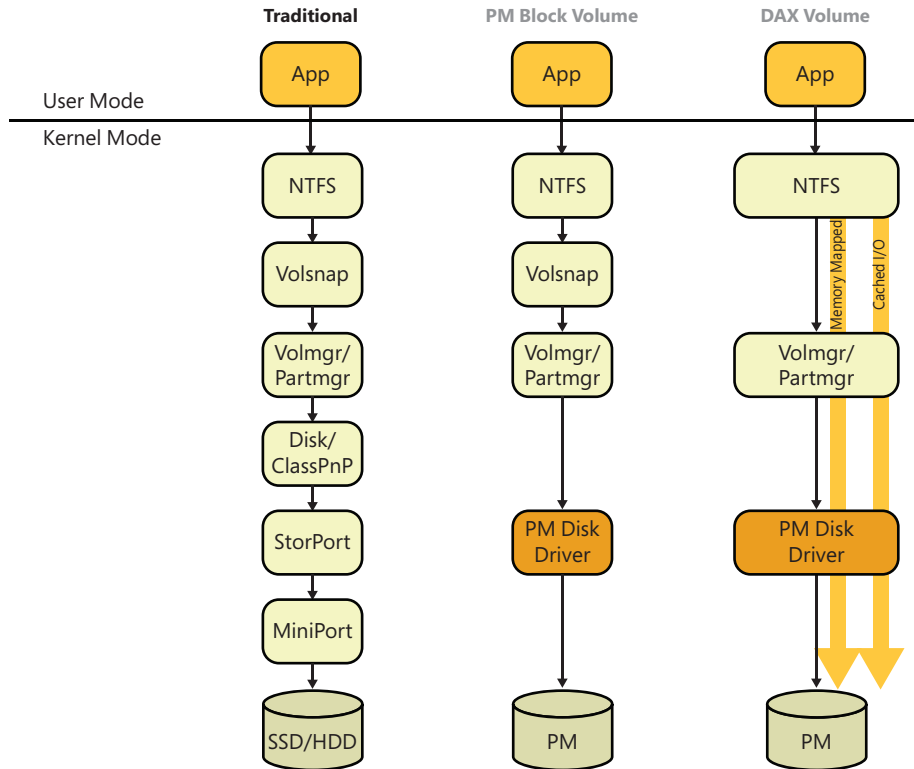

FIGURE 11-76 Device I/O stack comparison between traditional volumes, block mode volumes, and DAX volumes.

File system filter drivers and DAX

Legacy filter drivers and minifilters don't work with DAX volumes. These kinds of drivers usually augment file system functionality, often interacting with all the operations that a file system driver manages. There are different classes of filters providing new capabilities or modifying existing functionality of the file system driver: antivirus, encryption, replication, compression, Hierarchical Storage Management (HSM), and so on. The DAX driver model significantly modifies how DAX volumes interact with such components.

As previously discussed in this chapter, when a file is mapped in memory, the file system in DAX mode does not receive any read or write I/O requests, neither do all the filter drivers that reside above or below the file system driver. This means that filter drivers that rely on data interception will not work. To minimize possible compatibility issues, existing minifilters will not receive a notification (through the *InstanceSetup* callback) when a DAX volume is mounted. New and updated minifilter drivers that still want to operate with DAX volumes need to specify the *FLTFL_REGISTRATION_SUPPORT_DAX_VOLUME* flag when they register with the filter manager through *FltRegisterFilter* kernel API.

Minifilters that decide to support DAX volumes have the limitation that they can't intercept any form of paging I/O. Data transformation filters (which provide encryption or compression) don't have any chance of working correctly for memory-mapped files; antimalware filters are impacted as

described earlier—because they must now perform scans on every open and close, losing the ability to determine whether or not a write truly happened. (The impact is mostly tied to the detection of a file last update time.) Legacy filters are no longer compatible: if a driver calls the *IoAttachDeviceToDevice Stack* API (or similar functions), the I/O manager simply fails the request (and logs an ETW event).

Flushing DAX mode I/Os

Traditional disks (HDD, SSD, NVme) always include a cache that improves their overall performance. When write I/Os are emitted from the storage driver, the actual data is first transferred into the cache, which will be written to the persistent medium later. The operating system provides correct flushing, which guarantees that data is written to final storage, and temporal order, which guarantees that data is written in the correct order. For normal cached I/O, an application can call the *FlushFileBuffers* API to ensure that the data is provably stored on the disk (this will generate an IRP with the *IRP_MJ_FLUSH_BUFFERS* major function code that the NTFS driver will implement). Noncached I/O is directly written to disk by NTFS so ordering and flushing aren't concerns.

With DAX-mode volumes, this is not possible anymore. After the file is mapped in memory, the NTFS driver has no knowledge of the data that is going to be written to disk. If an application is writing some critical data structures on a DAX volume and the power fails, the application has no guarantees that all of the data structures will have been correctly written in the underlying medium. Furthermore, it has no guarantees that the order in which the data was written was the requested one. This is because PM storage is implemented as classical physical memory from the CPU's point of view. The processor uses the CPU caching mechanism, which uses its own caching mechanisms while reading or writing to DAX volumes.

As a result, newer versions of Windows 10 had to introduce new flush APIs for DAX-mapped regions, which perform the necessary work to optimally flush PM content from the CPU cache. The APIs are available for both user-mode applications and kernel-mode drivers and are highly optimized based on the CPU architecture (standard x64 systems use the CLFLUSH and CLWB opcodes, for example). An application that wants I/O ordering and flushing on DAX volumes can call *RtlGetNonVolatileToken* on a PM mapped region; the function yields back a nonvolatile token that can be subsequently used with the *RtlFlushNonVolatileMemory* or *RtlFlushNonVolatileMemoryRanges* APIs. Both APIs perform the actual flush of the data from the CPU cache to the underlying PM device.

Memory copy operations executed using standard OS functions perform, by default, *temporal* copy operations, meaning that data always passes through the CPU cache, maintaining execution ordering. *Nontemporal* copy operations, on the other hand, use specialized processor opcodes (again depending on the CPU architecture; x64 CPUs use the MOVNTI opcode) to bypass the CPU cache. In this case, ordering is not maintained, but execution is faster. *RtlWriteNonVolatileMemory* exposes memory copy operations to and from nonvolatile memory. By default, the API performs classical temporal copy operations, but an application can request a nontemporal copy through the *WRITE_NV_MEMORY_FLAG_NON_TEMPORAL* flag and thus execute a faster copy operation.

Large and huge pages support

Reading or writing a file on a DAX-mode volume through memory-mapped sections is handled by the memory manager in a similar way to non-DAX sections: if the `MEM_LARGE_PAGES` flag is specified at map time, the memory manager detects that one or more file extents point to enough aligned, contiguous physical space (NTFS allocates the file extents), and uses large (2 MB) or huge (1 GB) pages to map the physical DAX space. (More details on the memory manager and large pages are available in Chapter 5 of Part 1.) Large and huge pages have various advantages compared to traditional 4-KB pages. In particular, they boost the performance on DAX files because they require fewer lookups in the processor's page table structures and require fewer entries in the processor's translation lookaside buffer (TLB). For applications with a large memory footprint that randomly access memory, the CPU can spend a lot of time looking up TLB entries as well as reading and writing the page table hierarchy in case of TLB misses. In addition, using large/huge pages can also result in significant commit savings because only page directory parents and page directory (for large files only, not huge files) need to be charged. Page table space (4 KB per 2 MB of leaf VA space) charges are not needed or taken. So, for example, with a 2-TB file mapping, the system can save 4 GB of committed memory by using large and huge pages.

The NTFS driver cooperates with the memory manager to provide support for huge and large pages while mapping files that reside on DAX volumes:

- By default, each DAX partition is aligned on 2-MB boundaries.
- NTFS supports 2-MB clusters. A DAX volume formatted with 2-MB clusters is guaranteed to use only large pages for every file stored in the volume.
- 1-GB clusters are not supported by NTFS. If a file stored on a DAX volume is bigger than 1 GB, and if there are one or more file's extents stored in enough contiguous physical space, the memory manager will map the file using huge pages (huge pages use only two pages map levels, while large pages use three levels).

As introduced in Chapter 5, for normal memory-backed sections, the memory manager uses large and huge pages only if the extent describing the PM pages is properly aligned on the DAX volume. (The alignment is relative to the volume's LCN and not to the file VCN.) For large pages, this means that the extent needs to start at a 2-MB boundary, whereas for huge pages it needs to start at 1-GB boundary. If a file on a DAX volume is not entirely aligned, the memory manager uses large or huge pages only on those blocks that are aligned, while it uses standard 4-KB pages for any other blocks.

In order to facilitate and increase the usage of large pages, the NTFS file system provides the `FSCTL_SET_DAX_ALLOC_ALIGNMENT_HINT` control code, which an application can use to set its preferred alignment on new file extents. The I/O control code accepts a value that specifies the preferred alignment, a starting offset (which allows specifying where the alignment requirements begin), and some flags. Usually an application sends the IOCTL to the file system driver after it has created a brand-new file but before mapping it. In this way, while allocating space for the file, NTFS grabs free clusters that fall within the bounds of the preferred alignment.

If the requested alignment is not available (due to volume high fragmentation, for example), the IOCTL can specify the fallback behavior that the file system should apply: fail the request or revert to a fallback alignment (which can be specified as an input parameter). The IOCTL can even be used on an

already-existing file, for specifying alignment of new extents. An application can query the alignment of all the extents belonging to a file by using the `FSCTL_QUERY_FILE_REGIONS` control code or by using the `fsutil dax queryfilealignment` command-line tool.

EXPERIMENT: Playing with DAX file alignment

You can witness the different kinds of DAX file alignment using the FsTool application available in this book's downloadable resources. For this experiment, you need to have a DAX volume present on your machine. Open a command prompt window and perform the copy of a big file (we suggest at least 4 GB) into the DAX volume using this tool. In the following example, two DAX disks are mounted as the P: and Q: volumes. The `Big_Image.iso` file is copied into the Q: DAX volume by using a standard copy operation, started by the FsTool application:

```
D:\>fstool.exe /copy p:\Big_DVD_Image.iso q:\test.iso
NTFS / ReFS Tool v0.1
Copyright (C) 2018 Andrea Allievi (AaL186)
```

```
Copying "Big_DVD_Image.iso" to "test.iso" file... Success.
Total File-Copy execution time: 10 Sec - Transfer Rate: 495.52 MB/s.
Press any key to exit...
```

You can check the new `test.iso` file's alignment by using the `/queryalign` command-line argument of the `FsTool.exe` application, or by using the `queryFileAlignment` argument with the built-in `fsutil.exe` tool available in Windows:

```
D:\>fsutil dax queryFileAlignment q:\test.iso
```

File Region Alignment:

Region	Alignment	StartOffset	LengthInBytes
0	Other	0	0x1fd000
1	Large	0x1fd000	0x3b800000
2	Huge	0x3b9fd000	0xc0000000
3	Large	0xfb9fd000	0x13e00000
4	Other	0x10f7fd000	0x17e000

As you can read from the tool's output, the first chunk of the file has been stored in 4-KB aligned clusters. The offsets shown by the tool are not volume-relative offsets, or LCN, but file-relative offsets, or VCN. This is an important distinction because the alignment needed for large and huge pages mapping is relative to the volume's page offset. As the file keeps growing, some of its clusters will be allocated from a volume offset that is 2-MB or 1-GB aligned. In this way, those portions of the file can be mapped by the memory manager using large and huge pages. Now, as in the previous experiment, let's try to perform a DAX copy by specifying a target alignment hint:

```
P:\>fstool.exe /daxcopy p:\Big_DVD_Image.iso q:\test.iso /align:1GB
NTFS / ReFS Tool v0.1
Copyright (C) 2018 Andrea Allievi (AaL186)
```

```
Starting DAX copy...
Source file path: p:\Big_DVD_Image.iso.
Target file path: q:\test.iso.
Source Volume: p:\ - File system: NTFS - Is DAX Volume: True.
```



```
Target Volume: q:\ - File system: NTFS - Is DAX Volume: False.
```

```
Source file size: 4.34 GB  
Target file alignment (1GB) correctly set.
```

```
Performing file copy... Success!  
Total execution time: 6 Sec.  
Copy Speed: 618.81 MB/Sec
```

```
Press any key to exit...
```

```
P:\>fsutil dax queryFileAlignment q:\test.iso
```

```
File Region Alignment:
```

Region	Alignment	StartOffset	LengthInBytes
0	Huge	0	0x100000000
1	Large	0x100000000	0xf800000
2	Other	0x10f800000	0x17b000

In the latter case, the file was immediately allocated on the next 1-GB aligned cluster. The first 4-GB (0x100000000 bytes) of the file content are stored in contiguous space. When the memory manager maps that part of the file, it only needs to use four page director pointer table entries (PDPTs), instead of using 2048 page tables. This will save physical memory space and drastically improve the performance while the processor accesses the data located in the DAX section. To confirm that the copy has been really executed using large pages, you can attach a kernel debugger to the machine (even a local kernel debugger is enough) and use the **/debug** switch of the FsTool application:

```
P:\>fstool.exe /daxcopy p:\Big_DVD_Image.iso q:\test.iso /align:1GB /debug  
NTFS / ReFS Tool v0.1  
Copyright (C) 2018 Andrea Allievi (AaL186)
```

```
Starting DAX copy...
```

```
Source file path: p:\Big_DVD_Image.iso.  
Target file path: q:\test.iso.  
Source Volume: p:\ - File system: NTFS - Is DAX Volume: False.  
Target Volume: q:\ - File system: NTFS - Is DAX Volume: True.
```

```
Source file size: 4.34 GB  
Target file alignment (1GB) correctly set.
```

```
Performing file copy...
```

```
[Debug] (PID: 10412) Source and Target file correctly mapped.  
Source file mapping address: 0x000001F1C0000000 (DAX mode: 1).  
Target file mapping address: 0x000001F2C0000000 (DAX mode: 1).  
File offset : 0x0 - Alignment: 1GB.
```

```
Press enter to start the copy...
```

```
[Debug] (PID: 10412) File chunk's copy successfully executed.  
Press enter go to the next chunk / flush the file...
```

You can see the effective memory mapping using the debugger's **!pte** extension. First, you need to move to the proper process context by using the **.process** command, and then you can analyze the mapped virtual address shown by FsTool:

```
8: kd> !process 0n10412 0
Searching for Process with Cid == 28ac
PROCESS ffffd28124121080
  SessionId: 2 Cid: 28ac Peb: a29717c000 ParentCid: 31bc
  DirBase: 4cc491000 ObjectTable: fffff950f94060000 HandleCount: 49.
  Image: FsTool.exe

8: kd> .process /i fffffd28124121080
You need to continue execution (press 'g' <enter>) for the context
to be switched. When the debugger breaks in again, you will be in
the new process context.

8: kd> g
Break instruction exception - code 80000003 (first chance)
nt!DbgBreakPointWithStatus:
fffff804`3d7e8e50 cc int 3

8: kd> !pte 0x000001f2c0000000
                                VA 000001f2c0000000
PXE at FFFFB8DC6E371018 PPE at FFFFB8DC6E203E58 PDE at FFFFB8DC407CB000
contains 0A0000D57CEA8867 contains 8A000152400008E7 contains 0000000000000000
pfn d57cea8 ---DA--UWEV pfn 15240000 --LDA--UW-V LARGE PAGE pfn 15240000

PTE at FFFFB880F9600000
contains 0000000000000000
LARGE PAGE pfn 15240000
```

The **!pte** debugger command confirmed that the first 1 GB of space of the DAX file is mapped using huge pages. Indeed, neither the page directory nor the page table are present. The FsTool application can also be used to set the alignment of already existing files. The **FSCTL_SET_DAX_ALLOC_ALIGNMENT_HINT** control code does not actually move any data though; it just provides a hint for the new allocated file extents, as the file continues to grow in the future:

```
D:\>fstool e:\test.iso /align:2MB /offset:0
NTFS / ReFS Tool v0.1
Copyright (C) 2018 Andrea Allievi (AaL186)
```

```
Applying file alignment to "test.iso" (Offset 0x0)... Success.
Press any key to exit...
```

```
D:\>fsutil dax queryfileAlignment e:\test.iso
```

File Region Alignment:

Region	Alignment	StartOffset	LengthInBytes
0	Huge	0	0x100000000
1	Large	0x100000000	0xf800000
2	Other	0x10f800000	0x17b000

Virtual PM disks and storages spaces support

Persistent memory was specifically designed for server systems and mission-critical applications, like huge SQL databases, which need a fast response time and process thousands of queries per second. Often, these kinds of servers run applications in virtual machines provided by HyperV. Windows Server 2019 supports a new kind of virtual hard disk: virtual PM disks. Virtual PMs are backed by a VHDPMEM file, which, at the time of this writing, can only be created (or converted from a regular VHD file) by using Windows PowerShell. Virtual PM disks directly map chunks of space located on a real DAX disk installed in the host, via a VHDPMEM file, which must reside on that DAX volume.

When attached to a virtual machine, HyperV exposes a virtual PM device (VPMEM) to the guest. This virtual PM device is described by the NVDIMM Firmware interface table (NFIT) located in the virtual UEFI BIOS. (More details about the NVFIT table are available in the ACPI 6.2 specification.) The SCM Bus driver reads the table and creates the regular device objects representing the virtual NVDIMM device and the PM disk. The Pmem disk class driver manages the virtual PM disks in the same way as normal PM disks, and creates virtual volumes on the top of them. Details about the Windows Hypervisor and its components can be found in Chapter 9. Figure 11-77 shows the PM stack for a virtual machine that uses a virtual PM device. The dark gray components are parts of the virtualized stack, whereas light gray components are the same in both the guest and the host partition.

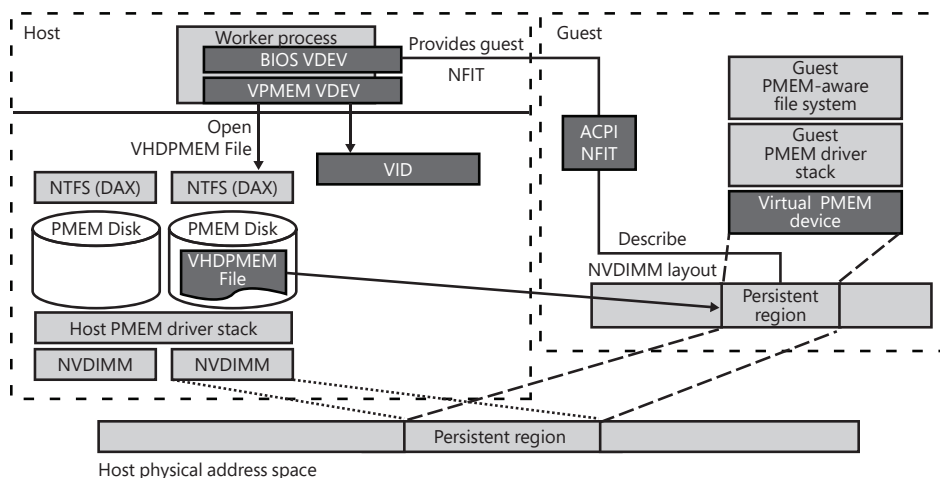

FIGURE 11-77 The virtual PM architecture.

A virtual PM device exposes a contiguous address space, virtualized from the host (this means that the host VHDPMEM files don't need to be contiguous). It supports both DAX and block mode, which, as in the host case, must be decided at volume-format time, and supports large and huge pages, which are leveraged in the same way as on the host system. Only generation 2 virtual machines support virtual PM devices and the mapping of VHDPMEM files.

Storage Spaces Direct in Windows Server 2019 also supports DAX disks in its virtual storage pools. One or more DAX disks can be part of an aggregated array of mixed-type disks. The PM disks in the array can be configured to provide the capacity or performance tier of a bigger tiered virtual disk or can be configured to act as a high-performance cache. More details on Storage Spaces are available later in this chapter.

EXPERIMENT: Create and mount a VHDPMEM image

As discussed in the previous paragraph, virtual PM disks can be created, converted, and assigned to a HyperV virtual machine using PowerShell. In this experiment, you need a DAX disk and a generation 2 virtual machine with Windows 10 October Update (RS5, or later releases) installed (describing how to create a VM is outside the scope of this experiment). Open an administrative Windows PowerShell prompt, move to your DAX-mode disk, and create the virtual PM disk (in the example, the DAX disk is located in the Q: drive):

```
PS Q:\> New-VHD VmPmemDis.vhdpmem -Fixed -SizeBytes 256GB -PhysicalSectorSizeBytes 4096
```

```
ComputerName      : 37-4611k2635
Path              : Q:\VmPmemDis.vhdpmem
VhdFormat        : VHDX
VhdType          : Fixed
FileSize         : 274882101248
Size             : 274877906944
MinimumSize      :
LogicalSectorSize : 4096
PhysicalSectorSize : 4096
BlockSize       : 0
ParentPath       :
DiskIdentifier    : 3AA0017F-03AF-4948-80BE-B40B4AA6BE24
FragmentationPercentage : 0
Alignment        : 1
Attached         : False
DiskNumber       :
IsPMEMCompatible : True
AddressAbstractionType : None
Number          :
```

Virtual PM disks can be of fixed size only, meaning that all the space is allocated for the virtual disk—this is by design. The second step requires you to create the virtual PM controller and attach it to your virtual machine. Make sure that your VM is switched off, and type the following command. You should replace “*TestPmVm*” with the name of your virtual machine):

```
PS Q:\> Add-VMPmemController -VMName "TestPmVm"
```

Finally, you need to attach the created virtual PM disk to the virtual machine’s PM controller:

```
PS Q:\> Add-VMHardDiskDrive "TestVm" PMEM -ControllerLocation 1 -Path 'Q:\VmPmemDis.vhdpmem'
```

You can verify the result of the operation by using the **Get-VMPmemController** command:

```
PS Q:\> Get-VMPmemController -VMName "TestPmVm"
```

```
VMName      ControllerNumber Drives
-----
TestPmVm    0                  {Persistent Memory Device on PMEM controller number 0 at location 1}
```

If you switch on your virtual machine, you will find that Windows detects a new virtual disk. In the virtual machine, open the Disk Management MMC snap-in Tool (diskmgmt.msc) and initialize the disk using GPT partitioning. Then create a simple volume, assign a drive letter to it, but don’t format it.

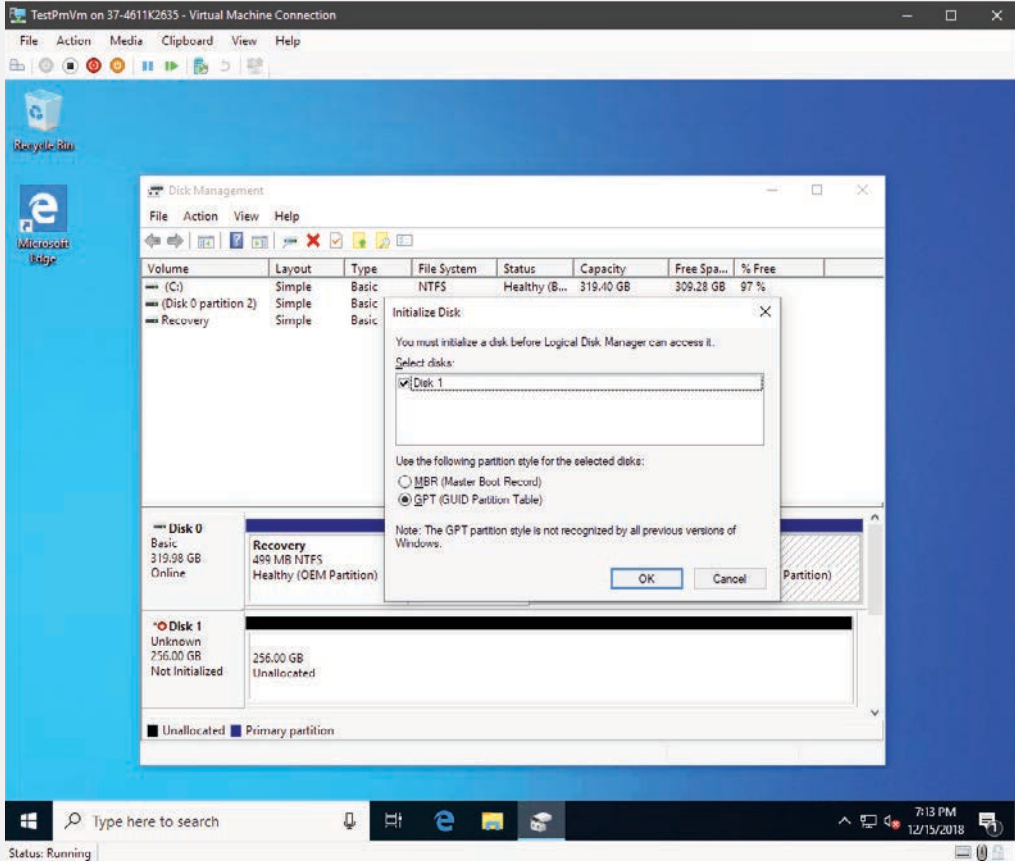

You need to format the virtual PM disk in DAX mode. Open an administrative command prompt window in the virtual machine. Assuming that your virtual-pm disk drive letter is E:, you need to use the following command:

```
C:\>format e: /DAX /fs:NTFS /q
The type of the file system is RAW.
The new file system is NTFS.
```

```
WARNING, ALL DATA ON NON-REMOVABLE DISK
DRIVE E: WILL BE LOST!
Proceed with Format (Y/N)? y
QuickFormatting 256.0 GB
Volume label (32 characters, ENTER for none)? DAX-In-Vm
Creating file system structures.
Format complete.
    256.0 GB total disk space.
    255.9 GB are available.
```

You can then confirm that the virtual disk has been formatted in DAX mode by using the `fsutil.exe` built-in tool, specifying the **`fsinfo volumeinfo`** command-line arguments:

```
C:\>fsutil fsinfo volumeinfo C:
Volume Name : DAX-In-Vm
Volume Serial Number : 0x1a1bdc32
Max Component Length : 255
File System Name : NTFS
Is ReadWrite
Not Thinly-Provisioned
Supports Case-sensitive filenames
Preserves Case of filenames
Supports Unicode in filenames
Preserves & Enforces ACL's
Supports Disk Quotas
Supports Reparse Points
Returns Handle Close Result Information
Supports POSIX-style Unlink and Rename
Supports Object Identifiers
Supports Named Streams
Supports Hard Links
Supports Extended Attributes
Supports Open By FileID
Supports USN Journal
Is DAX Volume
```

Resilient File System (ReFS)

The release of Windows Server 2012 R2 saw the introduction of a new advanced file system, the Resilient File System (also known as ReFS). This file system is part of a new storage architecture, called Storage Spaces, which, among other features, allows the creation of a tiered virtual volume composed of a solid-state drive and a classical rotational disk. (An introduction of Storage Spaces, and Tiered Storage, is presented later in this chapter). ReFS is a “write-to-new” file system, which means that file system metadata is *never* updated in place; updated metadata is written in a new place, and the old one is marked as deleted. This property is important and is one of the features that provides data integrity. The original goals of ReFS were the following:

1. Self-healing, online volume check and repair (providing close to zero unavailability due to file system corruption) and write-through support. (Write-through is discussed later in this section.)
2. Data integrity for all user data (hardware and software).
3. Efficient and fast file snapshots (block cloning).
4. Support for extremely large volumes (exabyte sizes) and files.
5. Automatic tiering of data and metadata, support for SMR (shingled magnetic recording) and future solid-state disks.

There have been different versions of ReFS. The one described in this book is referred to as ReFS v2, which was first implemented in Windows Server 2016. Figure 11-78 shows an overview of the different high-level implementations between NTFS and ReFS. Instead of completely rewriting the NTFS file system, ReFS uses another approach by dividing the implementation of NTFS into two parts: one part understands the on-disk format, and the other does not.

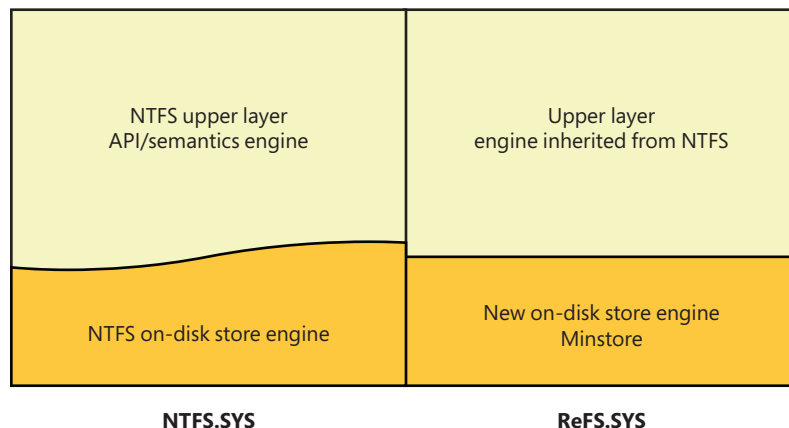

FIGURE 11-78 ReFS high-level implementation compared to NTFS.

ReFS replaces the on-disk storage engine with *Minstore*. Minstore is a recoverable object store library that provides a key-value table interface to its callers, implements allocate-on-write semantics for modification to those tables, and integrates with the Windows cache manager. Essentially, Minstore is a library that implements the core of a modern, scalable copy-on-write file system. Minstore is leveraged by ReFS to implement files, directories, and so on. Understanding the basics of Minstore is needed to describe ReFS, so let's start with a description of Minstore.

Minstore architecture

Everything in Minstore is a table. A table is composed of multiple rows, which are made of a key-value pair. Minstore tables, when stored on disk, are represented using B+ trees. When kept in volatile memory (RAM), they are represented using hash tables. B+ trees, also known as balanced trees, have different important properties:

1. They usually have a large number of children per node.
2. They store data pointers (a pointer to the disk file block that contains the key value) only on the leaves—not on internal nodes.
3. Every path from the root node to a leaf node is of the same length.

Other file systems (like NTFS) generally use B-trees (another data structure that generalizes a binary search-tree, not to be confused with the term “Binary tree”) to store the data pointer, along with the key, in each node of the tree. This technique greatly reduces the number of entries that can be packed into a node of a B-tree, thereby contributing to the increase in the number of levels in the B-tree, hence increasing the search time of a record.

Figure 11-79 shows an example of B+ tree. In the tree shown in the figure, the root and the internal node contain only keys, which are used for properly accessing the data located in the leaf’s nodes. Leaf nodes are all at the same level and are generally linked together. As a consequence, there is no need to emit lots of I/O operations for finding an element in the tree.

For example, let’s assume that Minstore needs to access the node with the key 20. The root node contains one key used as an index. Keys with a value above or equal to 13 are stored in one of the children indexed by the right pointer; meanwhile, keys with a value less than 13 are stored in one of the left children. When Minstore has reached the leaf, which contains the actual data, it can easily access the data also for node with keys 16 and 25 without performing any full tree scan.

Furthermore, the leaf nodes are usually linked together using linked lists. This means that for huge trees, Minstore can, for example, query all the files in a folder by accessing the root and the intermediate nodes only once—assuming that in the figure all the files are represented by the values stored in the leaves. As mentioned above, Minstore generally uses a B+ tree for representing different objects than files or directories.

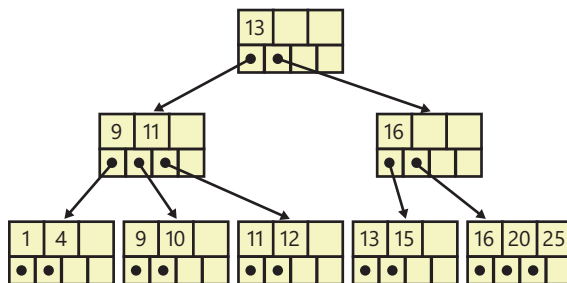

FIGURE 11-79 A sample B+ tree. Only the leaf nodes contain data pointers. Director nodes contain only links to children nodes.

In this book, we use the term B+ tree and B+ table for expressing the same concept. Minstore defines different kind of tables. A table can be created, it can have rows added to it, deleted from it, or updated inside of it. An external entity can enumerate the table or find a single row. The Minstore core is represented by the object table. The object table is an index of the location of every root (nonembedded) B+ trees in the volume. B+ trees can be embedded within other trees; a child tree’s root is stored within the row of a parent tree.

Each table in Minstore is defined by a composite and a schema. A composite is just a set of rules that describe the behavior of the root node (sometimes even the children) and how to find and manipulate each node of the B+ table. Minstore supports two kinds of root nodes, managed by their respective composites:

- **Copy on Write (CoW):** This kind of root node moves its location when the tree is modified. This means that in case of modification, a brand-new B+ tree is written while the old one is marked for deletion. In order to deal with these nodes, the corresponding composite needs to maintain an object ID that will be used when the table is written.
- **Embedded:** This kind of root node is stored in the data portion (the value of a leaf node) of an index entry of another B+ tree. The embedded composite maintains a reference to the index entry that stores the embedded root node.

Specifying a *schema* when the table is created tells Minstore what type of key is being used, how big the root and the leaf nodes of the table should be, and how the rows in the table are laid out. ReFS uses different schemas for files and directories. Directories are B+ table objects referenced by the object table, which can contain three different kinds of rows (files, links, and file IDs). In ReFS, the key of each row represents the name of the file, link, or file ID. Files are tables that contain attributes in their rows (attribute code and value pairs).

Every operation that can be performed on a table (close, modify, write to disk, or delete) is represented by a Minstore transaction. A Minstore transaction is similar to a database transaction: a unit of work, sometimes made up of multiple operations, that can succeed or fail only in an atomic way. The way in which tables are written to the disk is through a process known as *updating the tree*. When a tree update is requested, transactions are drained from the tree, and no transactions are allowed to start until the update is finished.

One important concept used in ReFS is the embedded table: a B+ tree that has the root node located in a row of another B+ tree. ReFS uses embedded tables extensively. For example, every file is a B+ tree whose roots are embedded in the row of directories. Embedded tables also support a move operation that changes the parent table. The size of the root node is fixed and is taken from the table's schema.

B+ tree physical layout

In Minstore, a B+ tree is made of buckets. Buckets are the Minstore equivalent of the general B+ tree nodes. Leaf buckets contain the data that the tree is storing; intermediate buckets are called director nodes and are used only for direct lookups to the next level in the tree. (In Figure 11-79, each node is a bucket.) Because director nodes are used only for directing traffic to child buckets, they need not have exact copies of a key in a child bucket but can instead pick a value between two buckets and use that. (In ReFS, usually the key is a compressed file name.) The data of an intermediate bucket instead contains both the logical cluster number (LCN) and a checksum of the bucket that it's pointing to. (The checksum allows ReFS to implement self-healing features.) The intermediate nodes of a Minstore table could be considered as a Merkle tree, in which every leaf node is labelled with the hash of a data block, and every nonleaf node is labelled with the cryptographic hash of the labels of its child nodes.

Every bucket is composed of an *index header* that describes the bucket, and a footer, which is an array of offsets pointing to the index entries in the correct order. Between the header and the footer there are the index entries. An index entry represents a row in the B+ table; a row is a simple data structure that gives the location and size of both the key and data (which both reside in the same bucket). Figure 11-80 shows an example of a leaf bucket containing three rows, indexed by the offsets located in the footer. In leaf pages, each row contains the key and the actual data (or the root node of another embedded tree).

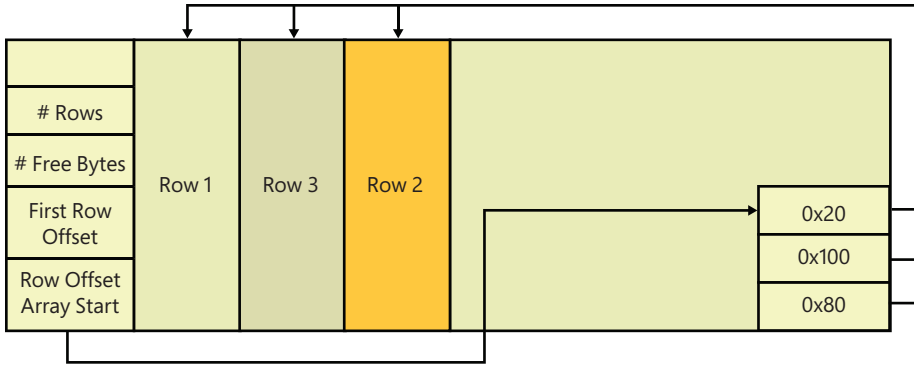

FIGURE 11-80 A leaf bucket with three index entries that are ordered by the array of offsets in the footer.

Allocators

When the file system asks Minstore to allocate a bucket (the B+ table requests a bucket with a process called *pinning the bucket*), the latter needs a way to keep track of the free space of the underlying medium. The first version of Minstore used a hierarchical allocator, which meant that there were multiple allocator objects, each of which allocated space out of its parent allocator. When the root allocator mapped the entire space of the volume, each allocator became a B+ tree that used the *lcn-count* table schema. This schema describes the row's key as a range of LCN that the allocator has taken from its parent node, and the row's value as an *allocator region*. In the original implementation, an allocator region described the state of each chunk in the region in relation to its children nodes: free or allocated and the owner ID of the object that owns it.

Figure 11-81 shows a simplified version of the original implementation of the hierarchical allocator. In the picture, a large allocator has only one allocation unit set: the space represented by the bit has been allocated for the medium allocator, which is currently empty. In this case, the medium allocator is a child of the large allocator.

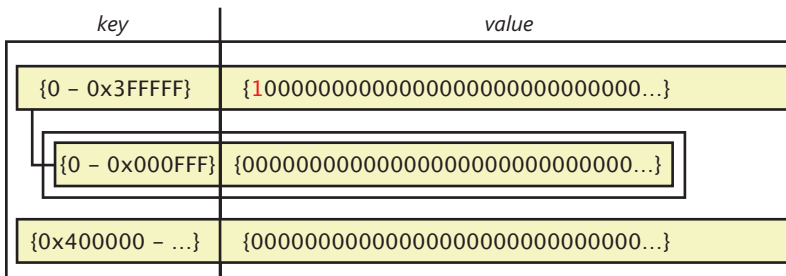

FIGURE 11-81 The old hierarchical allocator.

B+ tables deeply rely on allocators to get new buckets and to find space for the copy-on-write copies of existing buckets (implementing the write-to-new strategy). The latest Minstore version replaced the hierarchical allocator with a policy-driven allocator, with the goal of supporting a central location in the file system that would be able to support tiering. A tier is a type of the storage device—for

example, an SSD, NVMe, or classical rotational disk. Tiering is discussed later in this chapter. It is basically the ability to support a disk composed of a fast random-access zone, which is usually smaller than the slow sequential-only area.

The new policy-driven allocator is an optimized version (supporting a very large number of allocations per second) that defines different allocation areas based on the requested tier (the type of underlying storage device). When the file system requests space for new data, the central allocator decides which area to allocate from by a policy-driven engine. This policy engine is tiering-aware (this means that metadata is always written to the performance tiers and never to SMR capacity tiers, due to the random-write nature of the metadata), supports ReFS bands, and implements deferred allocation logic (DAL). The deferred allocation logic relies on the fact that when the file system creates a file, it usually also allocates the needed space for the file content. Minstore, instead of returning to the underlying file system an LCN range, returns a token containing the space reservation that provides a guarantee against the disk becoming full. When the file is ultimately written, the allocator assigns LCNs for the file's content and updates the metadata. This solves problems with SMR disks (which are covered later in this chapter) and allows ReFS to be able to create even huge files (64 TB or more) in less than a second.

The policy-driven allocator is composed of three central allocators, implemented on-disk as global B+ tables. When they're loaded in memory, the allocators are represented using AVL trees, though. An AVL tree is another kind of self-balancing binary tree that's not covered in this book. Although each row in the B+ table is still indexed by a range, the data part of the row could contain a bitmap or, as an optimization, only the number of allocated clusters (in case the allocated space is contiguous). The three allocators are used for different purposes:

- The Medium Allocator (MAA) is the allocator for each file in the namespace, except for some B+ tables allocated from the other allocators. The Medium Allocator is a B+ table itself, so it needs to find space for its metadata updates (which still follow the write-to-new strategy). This is the role of the Small Allocator (SAA).
- The Small Allocator (SAA) allocates space for itself, for the Medium Allocator, and for two tables: the Integrity State table (which allows ReFS to support Integrity Streams) and the Block Reference Counter table (which allows ReFS to support a file's block cloning).
- The Container Allocator (CAA) is used when allocating space for the container table, a fundamental table that provides cluster virtualization to ReFS and is also deeply used for container compaction. (See the following sections for more details.) Furthermore, the Container Allocator contains one or more entries for describing the space used by itself.

When the Format tool initially creates the basic data structures for ReFS, it creates the three allocators. The Medium Allocator initially describes all the volume's clusters. Space for the SAA and CAA metadata (which are B+ tables) is allocated from the MAA (this is the only time that ever happens in the volume lifetime). An entry for describing the space used by the Medium Allocator is inserted in the SAA. Once the allocators are created, additional entries for the SAA and CAA are no longer allocated from the Medium Allocator (except in case ReFS finds corruption in the allocators themselves).

To perform a write-to-new operation for a file, ReFS must first consult the MAA allocator to find space for the write to go to. In a tiered configuration, it does so with awareness of the tiers. Upon successful completion, it updates the file's stream extent table to reflect the new location of that extent and updates the file's metadata. The new B+ tree is then written to the disk in the free space block, and the old table is converted as free space. If the write is tagged as a write-through, meaning that the write must be discoverable after a crash, ReFS writes a log record for recording the write-to-new operation. (See the "ReFS write-through" section later in this chapter for further details).

Page table

When Minstore updates a bucket in the B+ tree (maybe because it needs to move a child node or even add a row in the table), it generally needs to update the parent (or director) nodes. (More precisely, Minstore uses different links that point to a new and an old child bucket for every node.) This is because, as we have described earlier, every director node contains the checksum of its leaves. Furthermore, the leaf node could have been moved or could even have been deleted. This leads to synchronization problems; for example, imagine a thread that is reading the B+ tree while a row is being deleted. Locking the tree and writing every modification on the physical medium would be prohibitively expensive. Minstore needs a convenient and fast way to keep track of the information about the tree. The *Minstore Page Table* (unrelated to the CPU's page table), is an in-memory hash table private to each Minstore's root table—usually the directory and file table—which keeps track of which bucket is dirty, freed, or deleted. This table will never be stored on the disk. In Minstore, the terms *bucket* and *page* are used interchangeably; a page usually resides in memory, whereas a bucket is stored on disk, but they express exactly the same high-level concept. *Trees* and *tables* also are used interchangeably, which explains why the page table is called as it is. The rows of a page table are composed of the LCN of the target bucket, as a Key, and a data structure that keeps track of the page states and assists the synchronization of the B+ tree as a value.

When a page is first read or created, a new entry will be inserted into the hash table that represents the page table. An entry into the page table can be deleted only if all the following conditions are met:

- There are no active transactions accessing the page.
- The page is clean and has no modifications.
- The page is not a copy-on-write new page of a previous one.

Thanks to these rules, clean pages usually come into the page table and are deleted from it repeatedly, whereas a page that is dirty would stay in the page table until the B+ tree is updated and finally written to disk. The process of writing the tree to stable media depends heavily upon the state in the page table at any given time. As you can see from Figure 11-82, the page table is used by Minstore as an in-memory cache, producing an implicit state machine that describes each state of a page.

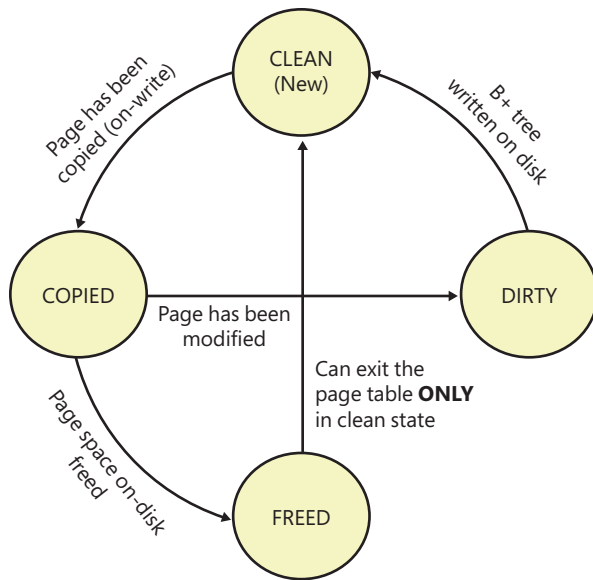

FIGURE 11-82 The diagram shows the states of a dirty page (bucket) in the page table. A new page is produced due to copy-on-write of an old page or if the B+ tree is growing and needs more space for storing the bucket.

Minstore I/O

In Minstore, reads and writes to the B+ tree in the final physical medium are performed in a different way: tree reads usually happen in portions, meaning that the read operation might only include some leaf buckets, for example, and occurs as part of transactional access or as a preemptive prefetch action. After a bucket is read into the cache (see the “Cache manager” section earlier in this chapter), Minstore still can’t interpret its data because the bucket checksum needs to be verified. The expected checksum is stored in the parent node: when the ReFS driver (which resides above Minstore) intercepts the read data, it knows that the node still needs to be validated: the parent node is already in the cache (the tree has been already navigated for reaching the child) and contains the checksum of the child. Minstore has all the needed information for verifying that the bucket contains valid data. Note that there could be pages in the page table that have been never accessed. This is because their checksum still needs to be validated.

Minstore performs tree updates by writing the entire B+ tree as a single transaction. The tree update process writes dirty pages of the B+ tree to the physical disk. There are multiple reasons behind a tree update—an application explicitly flushing its changes, the system running in low memory or similar conditions, the cache manager flushing cached data to disk, and so on. It’s worth mentioning that Minstore usually writes the new updated trees lazily with the lazy writer thread. As seen in the previous section, there are several triggers to kick in the lazy writer (for example, when the number of the dirty pages reaches a certain threshold).

Minstore is unaware of the actual reason behind the tree update request. The first thing that Minstore does is make sure that no other transactions are modifying the tree (using complex synchronization primitives). After initial synchronization, it starts to write dirty pages and with old deleted pages. In a

write-to-new implementation, a new page represents a bucket that has been modified and its content replaced; a freed page is an old page that needs to be unlinked from the parent. If a transaction wants to modify a leaf node, it copies (in memory) the root bucket and the leaf page; Minstore then creates the corresponding page table entries in the page table without modifying any link.

The tree update algorithm enumerates each page in the page table. However, the page table has no concept of which level in the B+ tree the page resides, so the algorithm checks even the B+ tree by starting from the more external node (usually the leaf), up to the root nodes. For each page, the algorithm performs the following steps:

1. Checks the state of the page. If it's a freed page, it skips the page. If it's a dirty page, it updates its parent pointer and checksum and puts the page in an internal list of pages to write.
2. Discards the old page.

When the algorithm reaches the root node, it updates its parent pointer and checksum directly in the object table and finally puts also the root bucket in the list of pages to write. Minstore is now able to write the new tree in the free space of the underlying volume, preserving the old tree in its original location. This is an important characteristic that summarizes the write-to-new strategy and allows the ReFS file system (which resides above Minstore) to support advanced online recovery features. Figure 11-83 shows an example of the tree update process for a B+ table that contains two new leaf pages (A' and B'). In the figure, pages located in the page table are represented in a lighter shade, whereas the old pages are shown in a darker shade.

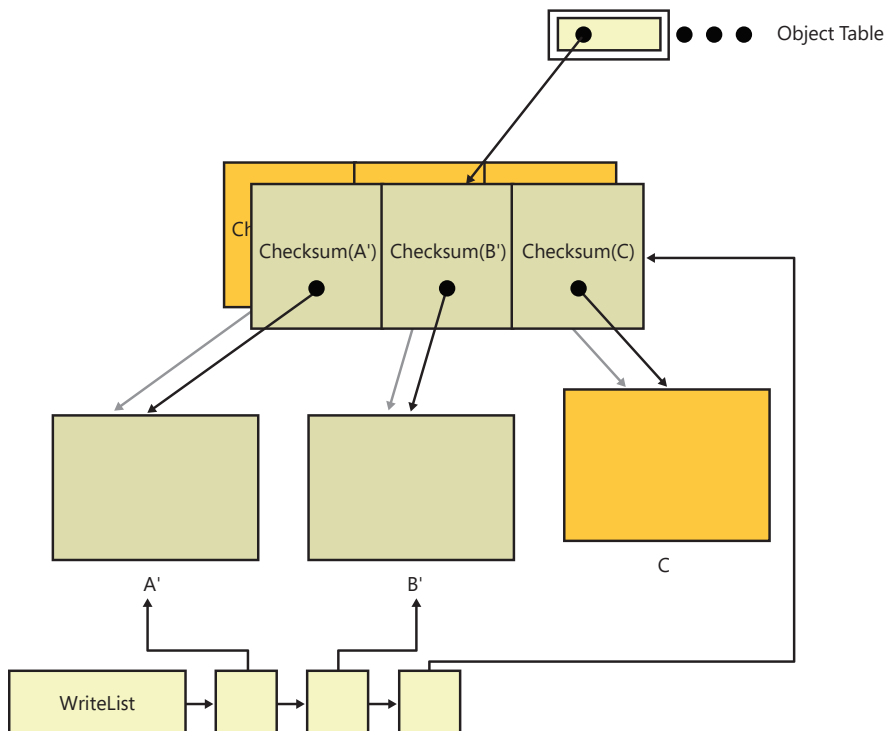

FIGURE 11-83 Minstore tree update process.

Maintaining exclusive access to the tree while performing the tree update can represent a performance issue; no one else can read or write from a B+ tree that has been exclusively locked. In the latest versions of Windows 10, B+ trees in Minstore became *generational*—a generation number is attached to each B+ tree. This means that a page in the tree can be dirty with regard to a specific generation. If a page is originally dirty for only a specific tree generation, it can be directly updated, with no need to copy-on-write because the final tree has still not been written to disk.

In the new model, the tree update process is usually split in two phases:

- **Failable phase:** Minstore acquires the exclusive lock on the tree, increments the tree's generation number, calculates and allocates the needed memory for the tree update, and finally drops the lock to shared.
- **Nonfailable phase:** This phase is executed with a shared lock (meaning that other I/O can read from the tree), Minstore updates the links of the director nodes and all the tree's checksums, and finally writes the final tree to the underlying disk. If another transaction wants to modify the tree while it's being written to disk, it detects that the tree's generation number is higher, so it copy-on-writes the tree again.

With the new schema, Minstore holds the exclusive lock only in the failable phase. This means that tree updates can run in parallel with other Minstore transactions, significantly improving the overall performance.

ReFS architecture

As already introduced in previous paragraphs, ReFS (the Resilient file system) is a hybrid of the NTFS implementation and Minstore, where every file and directory is a B+ tree configured by a particular schema. The file system volume is a flat namespace of directories. As discussed previously, NTFS is composed of different components:

- **Core FS support:** Describes the interface between the file system and other system components, like the cache manager and the I/O subsystem, and exposes the concept of file create, open, read, write, close, and so on.
- **High-level FS feature support:** Describes the high-level features of a modern file system, like file compression, file links, quota tracking, reparse points, file encryption, recovery support, and so on.
- **On-disk dependent components and data structures** MFT and file records, clusters, index package, resident and nonresident attributes, and so on (see the "The NT file system (NTFS)" section earlier in this chapter for more details).

ReFS keeps the first two parts largely unchanged and replaces the rest of the on-disk dependent components with Minstore, as shown in Figure 11-84.

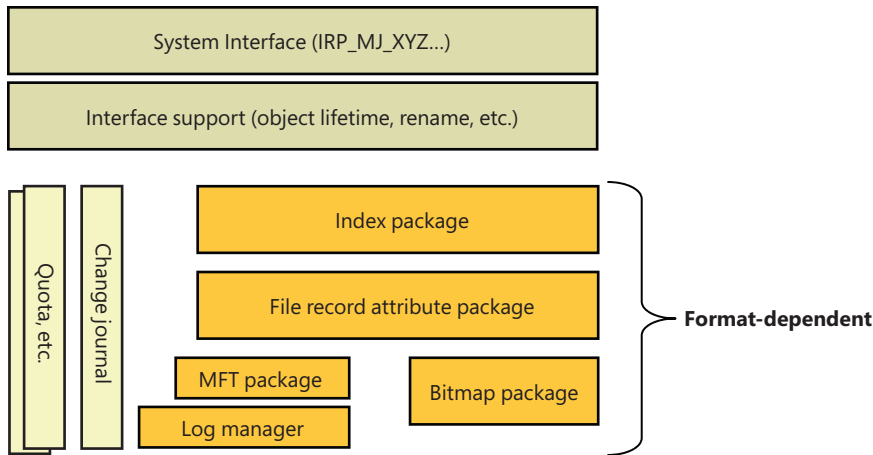

FIGURE 11-84 ReFS architecture's scheme.

In the “NTFS driver” section of this chapter, we introduced the entities that link a file handle to the file system’s on-disk structure. In the ReFS file system driver, those data structures (the stream control block, which represents the NTFS attribute that the caller is trying to read, and the file control block, which contains a pointer to the file record in the disk’s MFT) are still valid, but have a slightly different meaning in respect to their underlying durable storage. The changes made to these objects go through Minstore instead of being directly translated in changes to the on-disk MFT. As shown in Figure 11-85, in ReFS:

- A file control block (FCB) represents a single file or directory and, as such, contains a pointer to the Minstore B+ tree, a reference to the parent directory’s stream control block and key (the directory name). The FCB is pointed to by the file object, through the *FsContext2* field.
- A stream control block (SCB) represents an opened stream of the file object. The data structure used in ReFS is a simplified version of the NTFS one. When the SCB represents directories, though, the SCB has a link to the directory’s index, which is located in the B+ tree that represents the directory. The SCB is pointed to by the file object, through the *FsContext* field.
- A volume control block (VCB) represents a currently mounted volume, formatted by ReFS. When a properly formatted volume has been identified by the ReFS driver, a VCB data structure is created, attached into the volume device object extension, and linked into a list located in a global data structure that the ReFS file system driver allocates at its initialization time. The VCB contains a table of all the directory FCBs that the volume has currently opened, indexed by their reference ID.

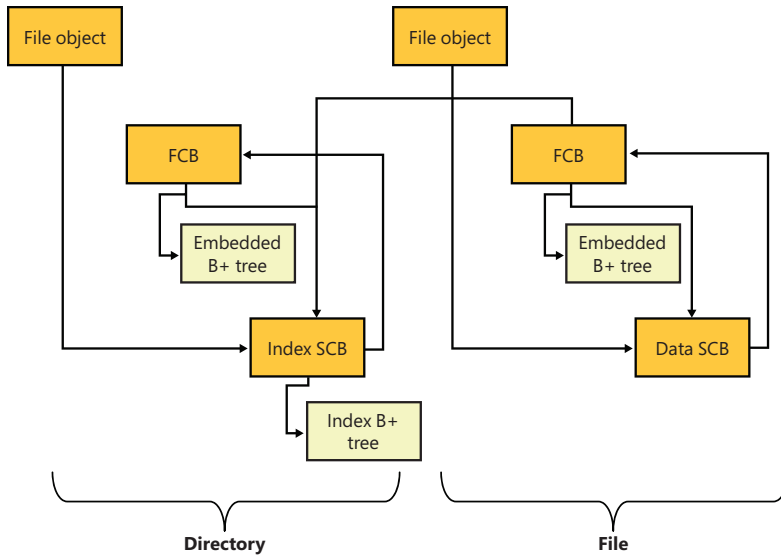

FIGURE 11-85 ReFS files and directories in-memory data structures.

In ReFS, every open file has a single FCB in memory that can be pointed to by different SCBs (depending on the number of streams opened). Unlike NTFS, where the FCB needs only to know the MFT entry of the file to correctly change an attribute, the FCB in ReFS needs to point to the B+ tree that represents the file record. Each row in the file's B+ tree represents an attribute of the file, like the ID, full name, extents table, and so on. The key of each row is the attribute code (an integer value).

File records are entries in the directory in which files reside. The root node of the B+ tree that represents a file is embedded into the directory entry's value data and never appears in the object table. The file data streams, which are represented by the extents table, are embedded B+ trees in the file record. The extents table is indexed by range. This means that every row in the extent table has a VCN range used as the row's key, and the LCN of the file's extent used as the row's value. In ReFS, the extents table could become very large (it is indeed a regular B+ tree). This allows ReFS to support huge files, bypassing the limitations of NTFS.

Figure 11-86 shows the object table, files, directories, and the file extent table, which in ReFS are all represented through B+ trees and provide the file system namespace.

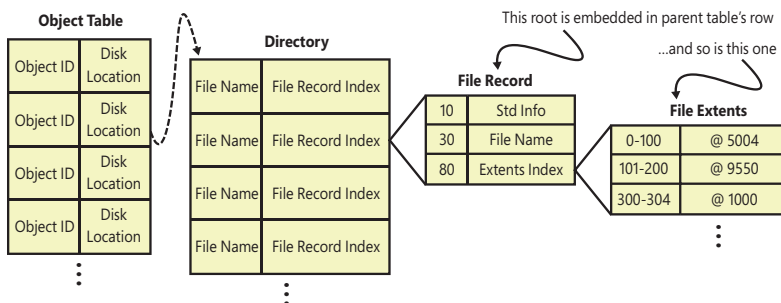

FIGURE 11-86 Files and directories in ReFS.

Directories are Minstore B+ trees that are responsible for the single, flat namespace. A ReFS directory can contain:

- Files
- Links to directories
- Links to other files (file IDs)

Rows in the directory B+ tree are composed of a *<key, <type, value>>* pair, where the key is the entry's name and the value depends on the type of directory entry. With the goal of supporting queries and other high-level semantics, Minstore also stores some internal data in invisible directory rows. These kinds of rows have their key starting with a Unicode zero character. Another row that is worth mentioning is the directory's file row. Every directory has a record, and in ReFS that file record is stored as a file row in the self-same directory, using a well-known zero key. This has some effect on the in-memory data structures that ReFS maintains for directories. In NTFS, a directory is really a property of a file record (through the Index Root and Index Allocation attributes); in ReFS, a directory is a file record stored in the directory itself (called directory index record). Therefore, whenever ReFS manipulates or inspects files in a directory, it must ensure that the directory index is open and resident in memory. To be able to update the directory, ReFS stores a pointer to the directory's index record in the opened stream control block.

The described configuration of the ReFS B+ trees does not solve an important problem. Every time the system wants to enumerate the files in a directory, it needs to open and parse the B+ tree of each file. This means that a lot of I/O requests to different locations in the underlying medium are needed. If the medium is a rotational disk, the performance would be rather bad.

To solve the issue, ReFS stores a *STANDARD_INFORMATION* data structure in the root node of the file's embedded table (instead of storing it in a row of the child file's B+ table). The *STANDARD_INFORMATION* data includes all the information needed for the enumeration of a file (like the file's access time, size, attributes, security descriptor ID, the update sequence number, and so on). A file's embedded root node is stored in a leaf bucket of the parent directory's B+ tree. By having the data structure located in the file's embedded root node, when the system enumerates files in a directory, it only needs to parse entries in the directory B+ tree without accessing any B+ tables describing individual files. The B+ tree that represents the directory is already in the page table, so the enumeration is quite fast.

ReFS on-disk structure

This section describes the on-disk structure of a ReFS volume, similar to the previous NTFS section. The section focuses on the differences between NTFS and ReFS and will not cover the concepts already described in the previous section.

The Boot sector of a ReFS volume consists of a small data structure that, similar to NTFS, contains basic volume information (serial number, cluster size, and so on), the file system identifier (the ReFS OEM string and version), and the ReFS container size (more details are covered in the "Shingled magnetic recording (SMR) volumes" section later in the chapter). The most important data structure in the volume is the volume super block. It contains the offset of the latest volume checkpoint records and

is replicated in three different clusters. ReFS, to be able to mount a volume, reads one of the volume checkpoints, verifies and parses it (the checkpoint record includes a checksum), and finally gets the offset of each global table.

The volume mounting process opens the object table and gets the needed information for reading the root directory, which contains all of the directory trees that compose the volume namespace. The object table, together with the container table, is indeed one of the most critical data structures that is the starting point for all volume metadata. The container table exposes the virtualization namespace, so without it, ReFS would not be able to correctly identify the final location of any cluster. Minstore optionally allows clients to store information within its object table rows. The object table row values, as shown in Figure 11-87, have two distinct parts: a portion owned by Minstore and a portion owned by ReFS. ReFS stores parent information as well as a high watermark for USN numbers within a directory (see the section “Security and change journal” later in this chapter for more details).

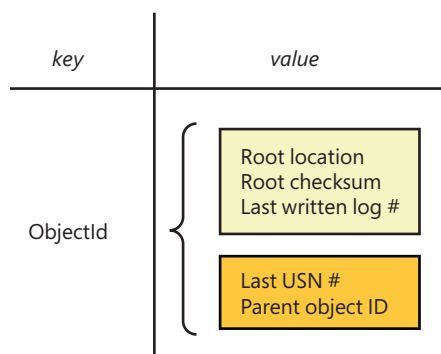

FIGURE 11-87 The object table entry composed of a ReFS part (bottom rectangle) and Minstore part (top rectangle).

Object IDs

Another problem that ReFS needs to solve regards file IDs. For various reasons—primarily for tracking and storing metadata about files in an efficient way without tying information to the namespace—ReFS needs to support applications that open a file through their file ID (using the *OpenFileById* API, for example). NTFS accomplishes this through the *\$Extend\\$ObjId* file (using the *\$0* index root attribute; see the previous NTFS section for more details). In ReFS, assigning an ID to every directory is trivial; indeed, Minstore stores the object ID of a directory in the object table. The problem arises when the system needs to be able to assign an ID to a file; ReFS doesn't have a central file ID repository like NTFS does. To properly find a file ID located in a directory tree, ReFS splits the file ID space into two portions: the directory and the file. The directory ID consumes the directory portion and is indexed into the key of an object table's row. The file portion is assigned out of the directory's internal file ID space. An ID that represents a directory usually has a zero in its file portion, but all files inside the directory share the same directory portion. ReFS supports the concept of file IDs by adding a separate row (composed of a *<FileId, FileName>* pair) in the directory's B+ tree, which maps the file ID to the file name within the directory.

When the system is required to open a file located in a ReFS volume using its file ID, ReFS satisfies the request by:

1. Opening the directory specified by the directory portion
2. Querying the *FileId* row in the directory B+ tree that has the key corresponding to the file portion
3. Querying the directory B+ tree for the file name found in the last lookup.

Careful readers may have noted that the algorithm does not explain what happens when a file is renamed or moved. The ID of a renamed file should be the same as its previous location, even if the ID of the new directory is different in the directory portion of the file ID. ReFS solves the problem by replacing the original file ID entry, located in the old directory B+ tree, with a new “tombstone” entry, which, instead of specifying the target file name in its value, contains the new assigned ID of the renamed file (with both the directory and the file portion changed). Another new File ID entry is also allocated in the new directory B+ tree, which allows assigning the new local file ID to the renamed file. If the file is then moved to yet another directory, the second directory has its ID entry deleted because it’s no longer needed; one tombstone, at most, is present for any given file.

Security and change journal

The mechanics of supporting Windows object security in the file system lie mostly in the higher components that are implemented by the portions of the file system remained unchanged since NTFS. The underlying on-disk implementation has been changed to support the same set of semantics. In ReFS, object security descriptors are stored in the volume’s global security directory B+ table. A hash is computed for every security descriptor in the table (using a proprietary algorithm, which operates only on self-relative security descriptors), and an ID is assigned to each.

When the system attaches a new security descriptor to a file, the ReFS driver calculates the security descriptor’s hash and checks whether it’s already present in the global security table. If the hash is present in the table, ReFS resolves its ID and stores it in the *STANDARD_INFORMATION* data structure located in the embedded root node of the file’s B+ tree. In case the hash does not already exist in the global security table, ReFS executes a similar procedure but first adds the new security descriptor in the global B+ tree and generates its new ID.

The rows of the global security table are of the format `<<hash, ID>, <security descriptor, ref. count>>`, where the *hash* and the *ID* are as described earlier, the *security descriptor* is the raw byte payload of the security descriptor itself, and *ref. count* is a rough estimate of how many objects on the volume are using the security descriptor.

As described in the previous section, NTFS implements a change journal feature, which provides applications and services with the ability to query past changes to files within a volume. ReFS implements an NTFS-compatible change journal implemented in a slightly different way. The ReFS journal stores change entries in the change journal file located in another volume’s global Minstore B+ tree, the metadata directory table. ReFS opens and parses the volume’s change journal file only once the volume is mounted. The maximum size of the journal is stored in the *\$USN_MAX* attribute of the journal

file. In ReFS, each file and directory contains its last USN (update sequence number) in the *STANDARD_INFORMATION* data structure stored in the embedded root node of the parent directory. Through the journal file and the USN number of each file and directory, ReFS can provide the three FSCTL used for reading and enumerate the volume journal file:

- **FSCTL_READ_USN_JOURNAL:** Reads the USN journal directly. Callers specify the journal ID they're reading and the number of the USN record they expect to read.
- **FSCTL_READ_FILE_USN_DATA:** Retrieves the USN change journal information for the specified file or directory.
- **FSCTL_ENUM_USN_DATA:** Scans all the file records and enumerates only those that have last updated the USN journal with a USN record whose USN is within the range specified by the caller. ReFS can satisfy the query by scanning the object table, then scanning each directory referred to by the object table, and returning the files in those directories that fall within the timeline specified. This is slow because each directory needs to be opened, examined, and so on. (Directories' B+ trees can be spread across the disk.) The way ReFS optimizes this is that it stores the highest USN of all files in a directory in that directory's object table entry. This way, ReFS can satisfy this query by visiting only directories it knows are within the range specified.

ReFS advanced features

In this section, we describe the advanced features of ReFS, which explain why the ReFS file system is a better fit for large server systems like the ones used in the infrastructure that provides the Azure cloud.

File's block cloning (snapshot support) and sparse VDL

Traditionally, storage systems implement snapshot and clone functionality at the volume level (see dynamic volumes, for example). In modern datacenters, when hundreds of virtual machines run and are stored on a unique volume, such techniques are no longer able to scale. One of the original goals of the ReFS design was to support file-level snapshots and scalable cloning support (a VM typically maps to one or a few files in the underlying host storage), which meant that ReFS needed to provide a fast method to clone an entire file or even only chunks of it. Cloning a range of blocks from one file into a range of another file allows not only file-level snapshots but also finer-grained cloning for applications that need to shuffle blocks within one or more files. VHD diff-disk merge is one example.

ReFS exposes the new *FSCTL_DUPLICATE_EXTENTS_TO_FILE* to duplicate a range of blocks from one file into another range of the same file or to a different file. Subsequent to the clone operation, writes into cloned ranges of either file will proceed in a write-to-new fashion, preserving the cloned block. When there is only one remaining reference, the block can be written in place. The source and target file handle, and all the details from which the block should be cloned, which blocks to clone from the source, and the target range are provided as parameters.

EXPERIMENT: Witnessing ReFS snapshot support through HyperV

In this experiment, you're going to use HyperV for testing the volume snapshot support of ReFS. Using the HyperV manager, you need to create a virtual machine and install any operating system on it. At the first boot, take a checkpoint on the VM by right-clicking the virtual machine name and selecting the **Checkpoint** menu item. Then, install some applications on the virtual machine (the example below shows a Windows Server 2012 machine with Office installed) and take another checkpoint.

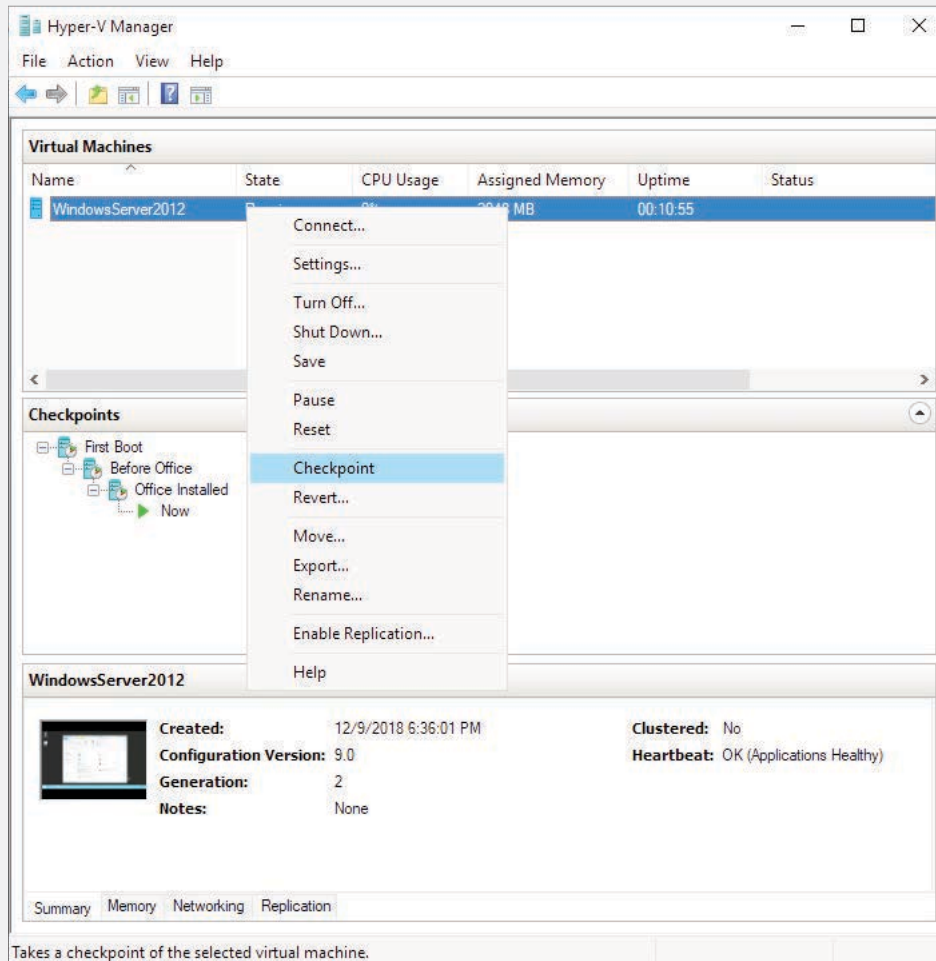

If you turn off the virtual machine and, using File Explorer, locate where the virtual hard disk file resides, you will find the virtual hard disk and multiple other files that represent the differential content between the current checkpoint and the previous one.

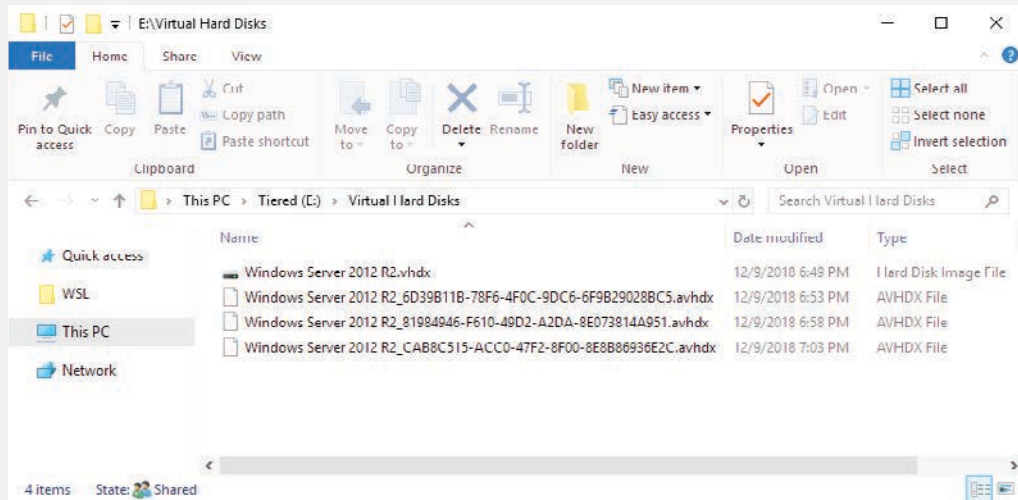

If you open the HyperV Manager again and delete the entire checkpoint tree (by right-clicking the first root checkpoint and selecting the **Delete Checkpoint Subtree** menu item), you will find that the entire merge process takes only a few seconds. This is explained by the fact that HyperV uses the block-cloning support of ReFS, through the `FSCTL_DUPLICATE_EXTENTS_TO_FILE` I/O control code, to properly merge the checkpoints' content into the base virtual hard disk file. As explained in the previous paragraphs, block cloning doesn't actually move any data. If you repeat the same experiment with a volume formatted using an exFAT or NTFS file system, you will find that the time needed to merge the checkpoints is much larger.

ReFS write-through

One of the goals of ReFS was to provide close to zero unavailability due to file system corruption. In the next section, we describe all of the available online repair methods that ReFS employs to recover from disk damage. Before describing them, it's necessary to understand how ReFS implements write-through when it writes the transactions to the underlying medium.

The term *write-through* refers to any primitive modifying operation (for example, create file, extend file, or write block) that must not complete until the system has made a reasonable guarantee that the results of the operation will be visible after crash recovery. Write-through performance is critical for different I/O scenarios, which can be broken into two kinds of file system operations: data and metadata.

When ReFS performs an update-in-place to a file without requiring any metadata mutation (like when the system modifies the content of an already-allocated file, without extending its length), the write-through performance has minimal overhead. Because ReFS uses allocate-on-write for metadata, it's expensive to give write-through guarantees for other scenarios when metadata change. For example, ensuring that a file has been renamed implies that the metadata blocks from the root of the file system down to the block describing the file's name must be written to a new location. The allocate-on-write nature of ReFS has the property that it does not modify data in place. One implication of this is that recovery of the system should never have to undo any operations, in contrast to NTFS.

To achieve write-through, Minstore uses write-ahead-logging (or WAL). In this scheme, shown in Figure 11-89, the system appends records to a log that is logically infinitely long; upon recovery, the log is read and replayed. Minstore maintains a log of logical redo transaction records for all tables except the allocator table. Each log record describes an entire transaction, which has to be replayed at recovery time. Each transaction record has one or more operation redo records that describe the actual high-level operation to perform (such as *insert [key K / value V] pair in Table X*). The transaction record allows recovery to separate transactions and is the unit of atomicity (no transactions will be partially redone). Logically, logging is owned by every ReFS transaction; a small log buffer contains the log record. If the transaction is committed, the log buffer is appended to the in-memory volume log, which will be written to disk later; otherwise, if the transaction aborts, the internal log buffer will be discarded. Write-through transactions wait for confirmation from the log engine that the log has committed up until that point, while non-write-through transactions are free to continue without confirmation.

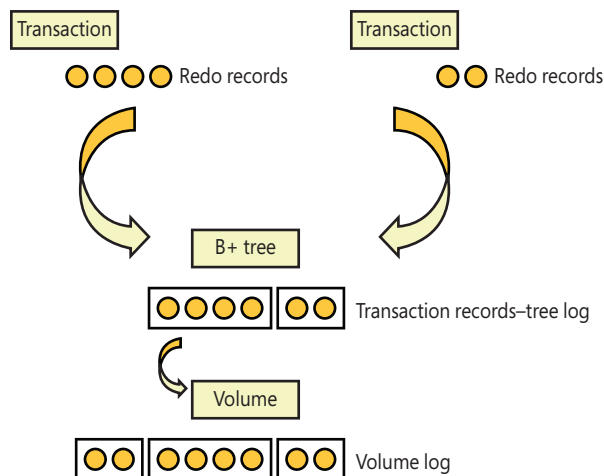

FIGURE 11-89 Scheme of Minstore's write-ahead logging.

Furthermore, ReFS makes use of checkpoints to commit some views of the system to the underlying disk, consequently rendering some of the previously written log records unnecessary. A transaction's redo log records no longer need to be redone once a checkpoint commits a view of the affected trees to disk. This implies that the checkpoint will be responsible for determining the range of log records that can be discarded by the log engine.

ReFS recovery support

To properly keep the file system volume available at all times, ReFS uses different recovery strategies. While NTFS has similar recovery support, the goal of ReFS is to get rid of any offline check disk utilities (like the Chkdsk tool used by NTFS) that can take many hours to execute in huge disks and require the operating system to be rebooted. There are mainly four ReFS recovery strategies:

- Metadata corruption is detected via checksums and error-correcting codes. Integrity streams validate and maintain the integrity of the file's data using a checksum of the file's actual content (the checksum is stored in a row of the file's B+ tree table), which maintains the integrity of the file itself and not only on its file-system metadata.
- ReFS intelligently repairs any data that is found to be corrupt, as long as another valid copy is available. Other copies might be provided by ReFS itself (which keeps additional copies of its own metadata for critical structures such as the object table) or through the volume redundancy provided by Storage Spaces (see the "Storage Spaces" section later in this chapter).
- ReFS implements the *salvage* operation, which removes corrupted data from the file system namespace while it's online.
- ReFS rebuilds lost metadata via best-effort techniques.

The first and second strategies are properties of the Minstore library on which ReFS depends (more details about the integrity streams are provided later in this section). The object table and all the global Minstore B+ tree tables contain a checksum for each link that points to the child (or director) nodes stored in different disk blocks. When Minstore detects that a block is not what it expects, it automatically attempts repair from one of its duplicated copies (if available). If the copy is not available, Minstore returns an error to the ReFS upper layer. ReFS responds to the error by initializing *online salvage*.

The term *salvage* refers to any fixes needed to restore as much data as possible when ReFS detects metadata corruption in a directory B+ tree. Salvage is the evolution of the *zap* technique. The goal of the zap was to bring back the volume online, even if this could lead to the loss of corrupted data. The technique removed all the corrupted metadata from the file namespace, which then became available after the repair.

Assume that a director node of a directory B+ tree becomes corrupted. In this case, the zap operation will fix the parent node, rewriting all the links to the child and rebalancing the tree, but the data originally pointed by the corrupted node will be completely lost. Minstore has no idea how to recover the entries addressed by the corrupted director node.

To solve this problem and properly restore the directory tree in the salvage process, ReFS needs to know subdirectories' identifiers, even when the directory table itself is not accessible (because it has a corrupted director node, for example). Restoring part of the lost directory tree is made possible by the introduction of a volume global table, called called the *parent-child* table, which provides a directory's information redundancy.

A key in the parent-child table represents the parent table's ID, and the data contains a list of child table IDs. Salvage scans this table, reads the child tables list, and re-creates a new non-corrupted B+ tree that contains all the subdirectories of the corrupted node. In addition to needing child table IDs, to

completely restore the corrupted parent directory, ReFS still needs the name of the child tables, which were originally stored in the keys of the parent B+ tree. The child table has a self-record entry with this information (of type *link to directory*; see the previous section for more details). The salvage process opens the recovered child table, reads the self-record, and reinserts the directory link into the parent table. The strategy allows ReFS to recover all the subdirectories of a corrupted director or root node (but still not the files). Figure 11-90 shows an example of zap and salvage operations on a corrupted root node representing the Bar directory. With the salvage operation, ReFS is able to quickly bring the file system back online and loses only two files in the directory.

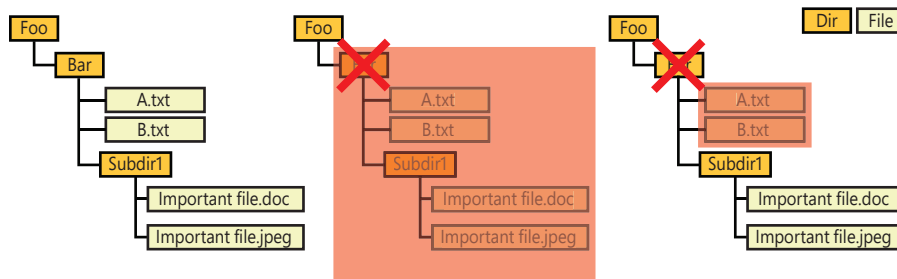

FIGURE 11-90 Comparison between the zap and salvage operations.

The ReFS file system, after salvage completes, tries to rebuild missing information using various best-effort techniques; for example, it can recover missing file IDs by reading the information from other buckets (thanks to the collating rule that separates files' IDs and tables). Furthermore, ReFS also augments the Minstore object table with a little bit of extra information to expedite repair. Although ReFS has these best-effort heuristics, it's important to understand that ReFS primarily relies on the redundancy provided by metadata and the storage stack in order to repair corruption without data loss.

In the very rare cases in which critical metadata is corrupted, ReFS can mount the volume in read-only mode, but not for any corrupted tables. For example, in case that the container table and all of its duplicates would all be corrupted, the volume wouldn't be mountable in read-only mode. By skipping over these tables, the file system can simply ignore the usage of such global tables (like the allocator, for example), while still maintaining a chance for the user to recover her data.

Finally, ReFS also supports file integrity streams, where a checksum is used to guarantee the integrity of a file's data (and not only of the file system's metadata). For integrity streams, ReFS stores the checksum of each run that composes the file's extent table (the checksum is stored in the data section of an extent table's row). The checksum allows ReFS to validate the integrity of the data before accessing it. Before returning any data that has integrity streams enabled, ReFS will first calculate its checksum and compares it to the checksum contained in the file metadata. If the checksums don't match, then the data is corrupt.

The ReFS file system exposes the `FSCTL_SCRUB_DATA` control code, which is used by the *scrubber* (also known as the data integrity scanner). The data integrity scanner is implemented in the `Discan.dll` library and is exposed as a task scheduler task, which executes at system startup and every week. When the scrubber sends the FSCTL to the ReFS driver, the latter starts an integrity check of the entire volume: the ReFS driver checks the boot section, each global B+ tree, and file system's metadata.



Note The online Salvage operation, described in this section, is different from its offline counterpart. The `refsutil.exe` tool, which is included in Windows, supports this operation. The tool is used when the volume is so corrupted that it is not even mountable in read-only mode (a rare condition). The offline Salvage operation navigates through all the volume clusters, looking for what appears to be metadata pages, and uses best-effort techniques to assemble them back together.

Leak detection

A cluster leak describes the situation in which a cluster is marked as allocated, but there are no references to it. In ReFS, cluster leaks can happen for different reasons. When a corruption is detected on a directory, online salvage is able to isolate the corruption and rebuild the tree, eventually losing only some files that were located in the root directory itself. A system crash before the tree update algorithm has written a Minstore transaction to disk can lead to a file name getting lost. In this case, the file's data is correctly written to disk, but ReFS has no metadata that point to it. The B+ tree table representing the file itself can still exist somewhere in the disk, but its embedded table is no longer linked in any directory B+ tree.

The built-in `refsutil.exe` tool available in Windows supports the *Leak Detection* operation, which can scan the entire volume and, using Minstore, navigate through the entire volume namespace. It then builds a list of every B+ tree found in the namespace (every tree is identified by a well-known data structure that contains an identification header), and, by querying the Minstore allocators, compares the list of each identified tree with the list of trees that have been marked valid by the allocator. If it finds a discrepancy, the leak detection tool notifies the ReFS file system driver, which will mark the clusters allocated for the found leaked tree as freed.

Another kind of leak that can happen on the volume affects the block reference counter table, such as when a cluster's range located in one of its rows has a higher reference counter number than the actual files that reference it. The lower-case tool is able to count the correct number of references and fix the problem.

To correctly identify and fix leaks, the leak detection tool must operate on an offline volume, but, using a similar technique to NTFS' online scan, it can operate on a read-only snapshot of the target volume, which is provided by the Volume Shadow Copy service.

EXPERIMENT: Use Refsutil to find and fix leaks on a ReFS volume

In this experiment, you use the built-in refsutil.exe tool on a ReFS volume to find and fix cluster leaks that could happen on a ReFS volume. By default, the tool doesn't require a volume to be unmounted because it operates on a read-only volume snapshot. To let the tool fix the found leaks, you can override the setting by using the **/x** command-line argument. Open an administrative command prompt and type the following command. (In the example, a 1 TB ReFS volume was mounted as the E: drive. The **/v** switch enables the tool's verbose output.)

```
C:\>refsutil leak /v e:
Creating volume snapshot on drive \\?\Volume{92aa4440-51de-4566-8c00-bc73e0671b92}...
Creating the scratch file...
Beginning volume scan... This may take a while...
Begin leak verification pass 1 (Cluster leaks)...
End leak verification pass 1. Found 0 leaked clusters on the volume.

Begin leak verification pass 2 (Reference count leaks)...
End leak verification pass 2. Found 0 leaked references on the volume.

Begin leak verification pass 3 (Compacted cluster leaks)...
End leak verification pass 3.

Begin leak verification pass 4 (Remaining cluster leaks)...
End leak verification pass 4. Fixed 0 leaks during this pass.

Finished.
Found leaked clusters: 0
Found reference leaks: 0
Total cluster fixed : 0
```

Shingled magnetic recording (SMR) volumes

At the time of this writing, one of the biggest problems that classical rotating hard disks are facing is in regard to the physical limitations inherent to the recording process. To increase disk size, the drive platter area density must always increase, while, to be able to read and write tiny units of information, the physical size of the heads of the spinning drives continue to get increasingly smaller. In turn, this causes the energy barrier for bit flips to decrease, which means that ambient thermal energy is more likely to accidentally flip bits, reducing data integrity. Solid state drives (SSD) have spread to a lot of consumer systems, large storage servers require more space and at a lower cost, which rotational drives still provide. Multiple solutions have been designed to overcome the rotating hard-disk problem. The most effective is called shingled magnetic recording (SMR), which is shown in Figure 11-91. Unlike PMR (perpendicular magnetic recording), which uses a parallel track layout, the head used for reading the data in SMR disks is smaller than the one used for writing. The larger writer means it can more effectively magnetize (write) the media without having to compromise readability or stability.

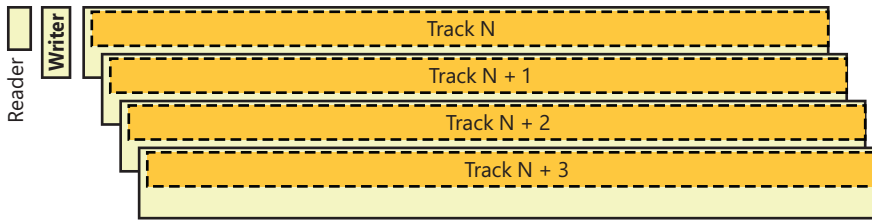

FIGURE 11-91 In SMR disks, the writer track is larger than the reader track.

The new configuration leads to some logical problems. It is almost impossible to write to a disk track without partially replacing the data on the consecutive track. To solve this problem, SMR disks split the drive into zones, which are technically called bands. There are two main kinds of zones:

- Conventional (or fast) zones work like traditional PMR disks, in which random writes are allowed.
- Write pointer zones are bands that have their own “write pointer” and require strictly sequential writes. (This is not exactly true, as host-aware SMR disks also support a concept of *write preferred* zones, in which random writes are still supported. This kind of zone isn’t used by ReFS though.)

Each band in an SMR disk is usually 256 MB and works as a basic unit of I/O. This means that the system can write in one band without interfering with the next band. There are three types of SMR disks:

- **Drive-managed:** The drive appears to the host identical to a nonshingled drive. The host does not need to follow any special protocol, as all handling of data and the existence of the disk zones and sequential write constraints is managed by the device’s firmware. This type of SMR disk is great for compatibility but has some limitations—the disk cache used to transform random writes in sequential ones is limited, band cleaning is complex, and sequential write detection is not trivial. These limitations hamper performance.
- **Host-managed:** The device requires strict adherence to special I/O rules by the host. The host is required to write sequentially as to not destroy existing data. The drive refuses to execute commands that violate this assumption. Host-managed drives support only sequential write zones and conventional zones, where the latter could be any media including non-SMR, drive-managed SMR, and flash.
- **Host-aware:** A combination of drive-managed and host-managed, the drive can manage the shingled nature of the storage and will execute any command the host gives it, regardless of whether it’s sequential. However, the host is aware that the drive is shingled and is able to query the drive for getting SMR zone information. This allows the host to optimize writes for the shingled nature while also allowing the drive to be flexible and backward-compatible. Host-aware drives support the concept of sequential write preferred zones.

At the time of this writing, ReFS is the only file system that can support host-managed SMR disks natively. The strategy used by ReFS for supporting these kinds of drives, which can achieve very large capacities (20 terabytes or more), is the same as the one used for tiered volumes, usually generated by Storage Spaces (see the final section for more information about Storage Spaces).

ReFS support for tiered volumes and SMR

Tiered volumes are similar to host-aware SMR disks. They're composed of a fast, random access area (usually provided by a SSD) and a slower sequential write area. This isn't a requirement, though; tiered disks can be composed by different random-access disks, even of the same speed. ReFS is able to properly manage tiered volumes (and SMR disks) by providing a new logical indirect layer between files and directory namespace on the top of the volume namespace. This new layer divides the volume into logical containers, which do not overlap (so a given cluster is present in only one container at time). A container represents an area in the volume and all containers on a volume are always of the same size, which is defined based on the type of the underlying disk: 64 MB for standard tiered disks and 256 MB for SMR disks. Containers are called *ReFS bands* because if they're used with SMR disks, the containers' size becomes exactly the same as the SMR bands' size, and each container maps one-to-one to each SMR band.

The indirection layer is configured and provided by the global container table, as shown in Figure 11-92. The rows of this table are composed by keys that store the ID and the type of the container. Based on the type of container (which could also be a compacted or compressed container), the row's data is different. For noncompacted containers (details about ReFS compaction are available in the next section), the row's data is a data structure that contains the mapping of the cluster range addressed by the container. This provides to ReFS a virtual LCN-to-real LCN namespace mapping.

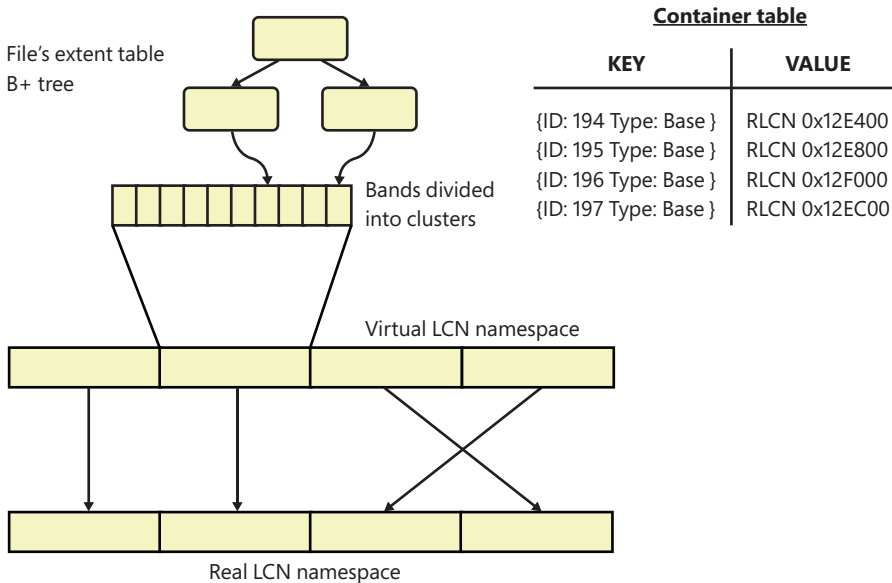

FIGURE 11-92 The container table provides a virtual LCN-to-real LCN indirection layer.

The container table is important: all the data managed by ReFS and Minstore needs to pass through the container table (with only small exceptions), so ReFS maintains multiple copies of this vital table. To perform an I/O on a block, ReFS must first look up the location of the extent's container to find the

real location of the data. This is achieved through the extent table, which contains target virtual LCN of the cluster range in the data section of its rows. The container ID is derived from the LCN, through a mathematical relationship. The new level of indirection allows ReFS to move the location of containers without consulting or modifying the file extent tables.

ReFS consumes tiers produced by Storage Spaces, hardware tiered volumes, and SMR disks. ReFS redirects small random I/Os to a portion of the faster tiers and destages those writes in batches to the slower tiers using sequential writes (destages happen at container granularity). Indeed, in ReFS, the term *fast tier* (or *flash tier*) refers to the random-access zone, which might be provided by the conventional bands of an SMR disk, or by the totality of an SSD or NVMe device. The term *slow tier* (or *HDD tier*) refers instead to the sequential write bands or to a rotating disk. ReFS uses different behaviors based on the class of the underlying medium. Non-SMR disks have no sequential requirements, so clusters can be allocated from anywhere on the volume; SMR disks, as discussed previously, need to have strictly sequential requirements, so ReFS never writes random data on the slow tier.

By default, all of the metadata that ReFS uses needs to stay in the fast tier; ReFS tries to use the fast tier even when processing general write requests. In non-SMR disks, as flash containers fill, ReFS moves containers from flash to HDD (this means that in a continuous write workload, ReFS is continually moving containers from flash into HDD). ReFS is also able to do the opposite when needed—select containers from the HDD and move them into flash to fill with subsequent writes. This feature is called *container rotation* and is implemented in two stages. After the storage driver has copied the actual data, ReFS modifies the container LCN mapping shown earlier. No modification in any file's extent table is needed.

Container rotation is implemented only for non-SMR disks. This is important, because in SMR disks, the ReFS file system driver never automatically moves data between tiers. Applications that are SMR disk-aware and want to write data in the SMR capacity tier can use the `FSCTL_SET_REFS_FILE_STRICTLY_SEQUENTIAL` control code. If an application sends the control code on a file handle, the ReFS driver writes all of the new data in the capacity tier of the volume.

EXPERIMENT: Witnessing SMR disk tiers

You can use the FsUtil tool, which is provided by Windows, to query the information of an SMR disk, like the size of each tier, the usable and free space, and so on. To do so, just run the tool in an administrative command prompt. You can launch the command prompt as administrator by searching for **cmd** in the Cortana Search box and by selecting **Run As Administrator** after right-clicking the **Command Prompt** label. Input the following parameters:

```
fsutil volume smrInfo <VolumeDrive>
```

replacing the `<VolumeDrive>` part with the drive letter of your SMR disk.

```

Administrator: Command Prompt

D:\Andrea>fsutil volume smrInfo d:

Size of randomly writable tier      : 130.75 GB
Free space in randomly writable tier : 122.22 GB
Size of SMR tier                    : 12.61 TB
Free space in SMR tier              : 12.58 TB
Usable free space in SMR tier       : 12.58 TB
Recoverable Cluster(s)*           : 154.50 MB
Free Space Efficiency               : 99%
Garbage collection state (last status) : Inactive (0)

Cluster Count      % of Tier
-----
0x20b000          93%
0x1e8dcf
0xc9b0000
0xc94867d        99%
0xc947cd5        99%
0x9a8            0%

* Note that up to 512 MB (2 SMR Bands) of recoverable clusters may not be garbage collectible.

D:\Andrea>

```

Furthermore, you can start a garbage collection (see the next paragraph for details about this feature) through the following command:

```
fsutil volume smrGc <VolumeDrive> Action=startfullspeed
```

The garbage collection can even be stopped or paused through the relative *Action* parameter. You can start a more precise garbage collection by specifying the *loGranularity* parameter, which specifies the granularity of the garbage collection I/O, and using the *start* action instead of *startfullspeed*.

Container compaction

Container rotation has performance problems, especially when storing small files that don't usually fit into an entire band. Furthermore, in SMR disks, container rotation is never executed, as we explained earlier. Recall that each SMR band has an associated write pointer (hardware implemented), which identifies the location for sequential writing. If the system were to write before or after the write pointer in a non-sequential way, it would corrupt data located in other clusters (the SMR firmware must therefore refuse such a write).

ReFS supports two types of containers: base containers, which map a virtual cluster's range directly to physical space, and compacted containers, which map a virtual container to many different base containers. To correctly map the correspondence between the space mapped by a compacted container and the base containers that compose it, ReFS implements an allocation bitmap, which is stored in the rows of the global container index table (another table, in which every row describes a single compacted container). The bitmap has a bit set to 1 if the relative cluster is allocated; otherwise, it's set to 0.

Figure 11-93 shows an example of a base container (C32) that maps a range of virtual LCNs (0x8000 to 0x8400) to real volume's LCNs (0xB800 to 0xBC00, identified by R46). As previously discussed, the container ID of a given virtual LCN range is derived from the starting virtual cluster number; all the

containers are virtually contiguous. In this way, ReFS never needs to look up a container ID for a given container range. Container C32 of Figure 11-93 only has 560 clusters (0x230) contiguously allocated (out of its 1,024). Only the free space at the end of the base container can be used by ReFS. Or, for non-SMR disks, in case a big chunk of space located in the middle of the base container is freed, it can be reused too. Even for non-SMR disks, the important requirement here is that the space must be contiguous.

If the container becomes fragmented (because some small file extents are eventually freed), ReFS can convert the base container into a compacted container. This operation allows ReFS to reuse the container's free space, without reallocating any row in the extent table of the files that are using the clusters described by the container itself.

Cluster size: 64KB Container size: 64MB (0x400 clusters)
 Volume size: 1TB (0x1000000 clusters)

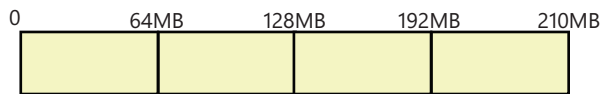

Base Container C32

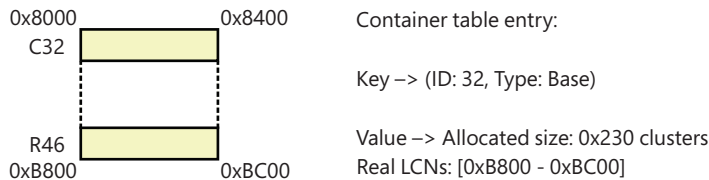

EXTENT TABLE

VCN RANGE	LCN	CONTAINER ID
[0 - 0x400]	0x18400	97
[0x400 - 0x800]	0x32000	200
[0x800 - 0xA00]	0x61E00	391
[0xA00 - 0xC00]	0x11200	68
[0xC00 - 0xD20]	0x8110	32

FIGURE 11-93 An example of a base container addressed by a 210 MB file. Container C32 uses only 35 MB of its 64 MB space.

ReFS provides a way to defragment containers that are fragmented. During normal system I/O activity, there are a lot of small files or chunks of data that need to be updated or created. As a result, containers located in the slow tier can hold small chunks of freed clusters and can become quickly fragmented. Container compaction is the name of the feature that generates new empty bands in the slow tier, allowing containers to be properly defragmented. Container compaction is executed only in the capacity tier of a tiered volume and has been designed with two different goals:

- **Compaction is the garbage collector for SMR-disks:** In SMR, ReFS can only write data in the capacity zone in a sequential manner. Small data can't be singularly updated in a container located in the slow tier. The data doesn't reside at the location pointed by the SMR write pointer, so any I/O of this kind can potentially corrupt other data that belongs to the band. In that case, the data is copied in a new band. Non-SMR disks don't have this problem; ReFS updates data residing in the small tier directly.
- **In non-SMR tiered volumes, compaction is the generator for container rotation:** The generated free containers can be used as targets for forward rotation when data is moved from the fast tier to the slow tier.

ReFS, at volume-format time, allocates some base containers from the capacity tier just for compaction; which are called *compacted reserved containers*. Compaction works by initially searching for fragmented containers in the slow tier. ReFS reads the fragmented container in system memory and defragments it. The defragmented data is then stored in a compacted reserved container, located in the capacity tier, as described above. The original container, which is addressed by the file extent table, becomes compacted. The range that describes it becomes virtual (compaction adds another indirection layer), pointing to virtual LCNs described by another base container (the reserved container). At the end of the compaction, the original physical container is marked as freed and is reused for different purposes. It also can become a new compacted reserved container. Because containers located in the slow tier usually become highly fragmented in a relatively small time, compaction can generate a lot of empty bands in the slow tier.

The clusters allocated by a compacted container can be stored in different base containers. To properly manage such clusters in a compacted container, which can be stored in different base containers, ReFS uses another extra layer of indirection, which is provided by the global container index table and by a different layout of the compacted container. Figure 11-94 shows the same container as Figure 11-93, which has been compacted because it was fragmented (272 of its 560 clusters have been freed). In the container table, the row that describes a compacted container stores the mapping between the cluster range described by the compacted container, and the virtual clusters described by the base containers. Compacted containers support a maximum of four different ranges (called *legs*). The four legs create the second indirection layer and allow ReFS to perform the container defragmentation in an efficient way. The allocation bitmap of the compacted container provides the second indirection layer, too. By checking the position of the allocated clusters (which correspond to a 1 in the bitmap), ReFS is able to correctly map each fragmented cluster of a compacted container.

In the example in Figure 11-94, the first bit set to 1 is at position 17, which is 0x11 in hexadecimal. In the example, one bit corresponds to 16 clusters; in the actual implementation, though, one bit corresponds to one cluster only. This means that the first cluster allocated at offset 0x110 in the compacted container C32 is stored at the virtual cluster 0x1F2E0 in the base container C124. The free space available after the cluster at offset 0x230 in the compacted container C32, is mapped into base container C56. The physical container R46 has been remapped by ReFS and has become an empty compacted reserved container, mapped by the base container C180.

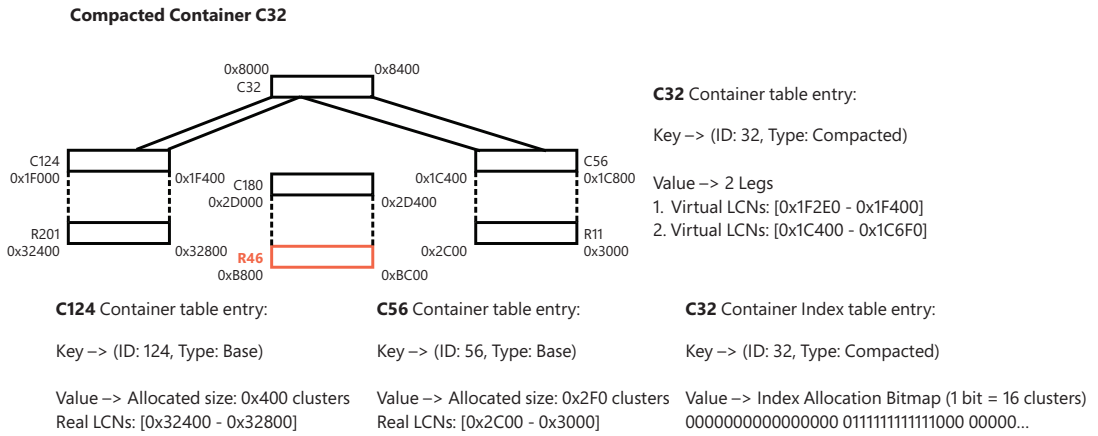

FIGURE 11-94 Container C32 has been compacted in base container C124 and C56.

In SMR disks, the process that starts the compaction is called garbage collection. For SMR disks, an application can decide to manually start, stop, or pause the garbage collection at any time through the *FSCTL_SET_REFS_SMR_VOLUME_GC_PARAMETERS* file system control code.

In contrast to NTFS, on non-SMR disks, the ReFS volume analysis engine can automatically start the container compaction process. ReFS keeps track of the free space of both the slow and fast tier and the available writable free space of the slow tier. If the difference between the free space and the available space exceeds a threshold, the volume analysis engine kicks off and starts the compaction process. Furthermore, if the underlying storage is provided by Storage Spaces, the container compaction runs periodically and is executed by a dedicated thread.

Compression and ghosting

ReFS does not support native file system compression, but, on tiered volumes, the file system is able to save more free containers on the slow tier thanks to container compression. Every time ReFS performs container compaction, it reads in memory the original data located in the fragmented base container. At this stage, if compression is enabled, ReFS compresses the data and finally writes it in a compressed compacted container. ReFS supports four different compression algorithms: LZNT1, LZX, XPRESS, and XPRESS_HUFF.

Many hierarchical storage management (HMR) software solutions support the concept of a *ghosted* file. This state can be obtained for many different reasons. For example, when the HSM migrates the user file (or some chunks of it) to a cloud service, and the user later modifies the copy located in the cloud through a different device, the HSM filter driver needs to keep track of which part of the file changed and needs to set the ghosted state on each modified file's range. Usually HMRs keep track of the ghosted state through their filter drivers. In ReFS, this isn't needed because the ReFS file system exposes a new I/O control code, *FSCTL_GHOST_FILE_EXTENTS*. Filter drivers can send the IOCTL to the ReFS driver to set part of the file as ghosted. Furthermore, they can query the file's ranges that are in the ghosted state through another I/O control code: *FSCTL_QUERY_GHOSTED_FILE_EXTENTS*.

ReFS implements ghosted files by storing the new state information directly in the file's extent table, which is implemented through an embedded table in the file record, as explained in the previous section. A filter driver can set the ghosted state for every range of the file (which must be cluster-aligned). When the ReFS driver intercepts a read request for an extent that is ghosted, it returns a `STATUS_GHOSTED` error code to the caller, which a filter driver can then intercept and redirect the read to the proper place (the cloud in the previous example).

Storage Spaces

Storage Spaces is the technology that replaces dynamic disks and provides virtualization of physical storage hardware. It has been initially designed for large storage servers but is available even in client editions of Windows 10. Storage Spaces also allows the user to create virtual disks composed of different underlying physical mediums. These mediums can have different performance characteristics.

At the time of this writing, Storage Spaces is able to work with four types of storage devices: Nonvolatile memory express (NVMe), flash disks, persistent memory (PM), SATA and SAS solid state drives (SSD), and classical rotating hard-disks (HDD). NVMe is considered the faster, and HDD is the slowest. Storage spaces was designed with four goals:

- **Performance:** Spaces implements support for a built-in server-side cache to maximize storage performance and support for tiered disks and RAID 0 configuration.
- **Reliability:** Other than span volumes (RAID 0), spaces supports Mirror (RAID 1 and 10) and Parity (RAID 5, 6, 50, 60) configurations when data is distributed through different physical disks or different nodes of the cluster.
- **Flexibility:** Storage spaces allows the system to create virtual disks that can be automatically moved between a cluster's nodes and that can be automatically shrunk or extended based on real space consumption.
- **Availability:** Storage spaces volumes have built-in fault tolerance. This means that if a drive, or even an entire server that is part of the cluster, fails, spaces can redirect the I/O traffic to other working nodes without any user intervention (and in a way). Storage spaces don't have a single point of failure.

Storage Spaces Direct is the evolution of the Storage Spaces technology. Storage Spaces Direct is designed for large datacenters, where multiple servers, which contain different slow and fast disks, are used together to create a pool. The previous technology didn't support clusters of servers that weren't attached to JBOD disk arrays; therefore, the term *direct* was added to the name. All servers are connected through a fast Ethernet connection (10GBe or 40GBe, for example). Presenting remote disks as local to the system is made possible by two drivers—the cluster miniport driver (Clusport.sys) and the cluster block filter driver (Clusbft.sys)—which are outside the scope of this chapter. All the storage physical units (local and remote disks) are added to a *storage pool*, which is the main unit of management, aggregation, and isolation, from where virtual disks can be created.

The entire storage cluster is mapped internally by Spaces using an XML file called *Blueprint*. The file is automatically generated by the Spaces GUI and describes the entire cluster using a tree of different

storage entities: *Racks*, *Chassis*, *Machines*, *JBODs* (Just a Bunch of Disks), and *Disks*. These entities compose each layer of the entire cluster. A server (machine) can be connected to different JBODs or have different disks directly attached to it. In this case, a JBOD is abstracted and represented only by one entity. In the same way, multiple machines might be located on a single chassis, which could be part of a server rack. Finally, the cluster could be made up of multiple server racks. By using the Blueprint representation, Spaces is able to work with all the cluster disks and redirect I/O traffic to the correct replacement in case a fault on a disk, JBOD, or machine occurs. Spaces Direct can tolerate a maximum of two contemporary faults.

Spaces internal architecture

One of the biggest differences between Spaces and dynamic disks is that Spaces creates virtual disk objects, which are presented to the system as actual disk device objects by the Spaces storage driver (*Spaceport.sys*). Dynamic disks operate at a higher level: virtual volume objects are exposed to the system (meaning that user mode applications can still access the original disks). The volume manager is the component responsible for creating the single volume composed of multiple dynamic volumes. The Storage Spaces driver is a filter driver (a full filter driver rather than a minifilter) that lies between the partition manager (*Partmgr.sys*) and the disk class driver.

Storage Spaces architecture is shown in Figure 11-95 and is composed mainly of two parts: a platform-independent library, which implements the Spaces core, and an environment part, which is platform-dependent and links the Spaces core to the current environment. The Environment layer provides to Storage Spaces the basic core functionalities that are implemented in different ways based on the platform on which they run (because storage spaces can be used as bootable entities, the Windows boot loader and boot manager need to know how to parse storage spaces, hence the need for both a UEFI and Windows implementation). The core basic functionality includes memory management routines (alloc, free, lock, unlock and so on), device I/O routines (Control, Pnp, Read, and Write), and synchronization methods. These functions are generally wrappers to specific system routines. For example, the read service, on Windows platforms, is implemented by creating an IRP of type *IRP_MJ_READ* and by sending it to the correct disk driver, while, on UEFI environments, it's implemented by using the *BLOCK_IO_PROTOCOL*.

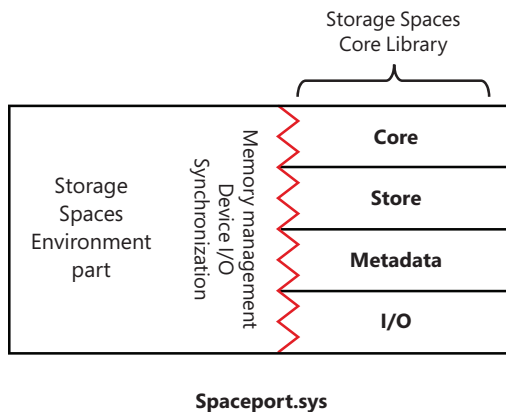

FIGURE 11-95 Storage Spaces architecture.

Other than the boot and Windows kernel implementation, storage spaces must also be available during crash dumps, which is provided by the Spacedump.sys crash dump filter driver. Storage Spaces is even available as a user-mode library (Backspace.dll), which is compatible with legacy Windows operating systems that need to operate with virtual disks created by Spaces (especially the VHD file), and even as a UEFI DXE driver (HyperSpace.efi), which can be executed by the UEFI BIOS, in cases where even the EFI System Partition itself is present on a storage space entity. Some new Surface devices are sold with a large solid-state disk that is actually composed of two or more fast NVMe disks.

Spaces Core is implemented as a static library, which is platform-independent and is imported by all of the different environment layers. It is composed of four layers: Core, Store, Metadata, and IO. The Core is the highest layer and implements all the services that Spaces provides. Store is the component that reads and writes records that belong to the cluster database (created from the Blueprint file). Metadata interprets the binary records read by the Store and exposes the entire cluster database through different objects: *Pool*, *Drive*, *Space*, *Extent*, *Column*, *Tier*, and *Metadata*. The IO component, which is the lowest layer, can emit I/Os to the correct device in the cluster in the proper sequential way, thanks to data parsed by higher layers.

Services provided by Spaces

Storage Spaces supports different disk type configurations. With Spaces, the user can create virtual disks composed entirely of fast disks (SSD, NVMe, and PM), slow disks, or even composed of all four supported disk types (hybrid configuration). In case of hybrid deployments, where a mix of different classes of devices are used, Spaces supports two features that allow the cluster to be fast and efficient:

- **Server cache:** Storage Spaces is able to hide a fast drive from the cluster and use it as a cache for the slower drives. Spaces supports PM disks to be used as a cache for NVMe or SSD disks, NVMe disks to be used as cache for SSD disks, and SSD disks to be used as cache for classical rotating HDD disks. Unlike tiered disks, the cache is invisible to the file system that resides on the top of the virtual volume. This means that the cache has no idea whether a file has been accessed more recently than another file. Spaces implements a fast cache for the virtual disk by using a log that keeps track of hot and cold blocks. Hot blocks represent parts of files (files' extents) that are often accessed by the system, whereas cold blocks represent part of files that are barely accessed. The log implements the cache as a queue, in which the hot blocks are always at the head, and cold blocks are at the tail. In this way, cold blocks can be deleted from the cache if it's full and can be maintained only on the slower storage; hot blocks usually stay in the cache for a longer time.
- **Tiering:** Spaces can create tiered disks, which are managed by ReFS and NTFS. Whereas ReFS supports SMR disks, NTFS only supports tiered disks provided by Spaces. The file system keeps track of the hot and cold blocks and rotates the bands based on the file's usage (see the "ReFS support for tiered volumes and SMR" section earlier in this chapter). Spaces provides to the file system driver support for pinning, a feature that can *pin* a file to the fast tier and lock it in the tier until it will be unpinned. In this case, no band rotation is ever executed. Windows uses the pinning feature to store the new files on the fast tier while performing an OS upgrade.

As already discussed previously, one of the main goals of Storage Spaces is flexibility. Spaces supports the creation of virtual disks that are extensible and consume only allocated space in the

underlying cluster's devices; this kind of virtual disk is called *thin provisioned*. Unlike fixed provisioned disks, where all of the space is allocated to the underlying storage cluster, thin provisioned disks allocate only the space that is actually used. In this way, it's possible to create virtual disks that are much larger than the underlying storage cluster. When available space gets low, a system administrator can dynamically add disks to the cluster. Storage Spaces automatically includes the new physical disks to the pool and redistributes the allocated blocks between the new disks.

Storage Spaces supports thin provisioned disks through *slabs*. A slab is a unit of allocation, which is similar to the ReFS container concept, but applied to a lower-level stack: the slab is an allocation unit of a virtual disk and not a file system concept. By default, each slab is 256 MB in size, but it can be bigger in case the underlying storage cluster allows it (i.e., if the cluster has a lot of available space.) Spaces core keeps track of each slab in the virtual disk and can dynamically allocate or free slabs by using its own allocator. It's worth noting that each slab is a point of reliability: in mirrored and parity configurations, the data stored in a slab is automatically replicated through the entire cluster.

When a thin provisioned disk is created, a size still needs to be specified. The virtual disk size will be used by the file system with the goal of correctly formatting the new volume and creating the needed metadata. When the volume is ready, Spaces allocates slabs only when new data is actually written to the disk—a method called *allocate-on-write*. Note that the provisioning type is not visible to the file system that resides on top of the volume, so the file system has no idea whether the underlying disk is thin or fixed provisioned.

Spaces gets rid of any single point of failure by making usage of mirroring and pairing. In big storage clusters composed of multiple disks, RAID 6 is usually employed as the parity solution. RAID 6 allows the failure of a maximum of two underlying devices and supports seamless reconstruction of data without any user intervention. Unfortunately, when the cluster encounters a single (or double) point of failure, the time needed to reconstruct the array (mean time to repair or MTTR) is high and often causes serious performance penalties.

Spaces solves the problem by using a local reconstruction code (LRC) algorithm, which reduces the number of reads needed to reconstruct a big disk array, at the cost of one additional parity unit. As shown in Figure 11-96, the LRC algorithm does so by dividing the disk array in different rows and by adding a parity unit for each row. If a disk fails, only the other disks of the row needs to be read. As a result, reconstruction of a failed array is much faster and more efficient.

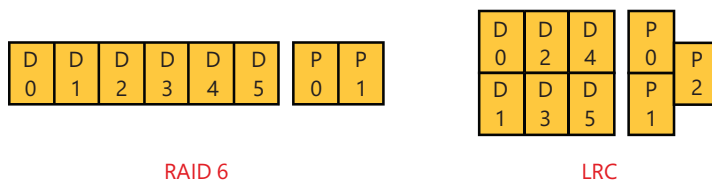

FIGURE 11-96 RAID 6 and LRC parity.

Figure 11-96 shows a comparison between the typical RAID 6 parity implementation and the LRC implementation on a cluster composed of eight drives. In the RAID 6 configuration, if one (or two) disk(s) fail(s), to properly reconstruct the missing information, the other six disks need to be read; in LRC, only the disks that belong to the same row of the failing disk need to be read.

EXPERIMENT: Creating tiered volumes

Storage Spaces is supported natively by both server and client editions of Windows 10. You can create tiered disks using the graphical user interface, or you can also use Windows PowerShell. In this experiment, you will create a virtual tiered disk, and you will need a workstation that, other than the Windows boot disk, also has an empty SSD and an empty classical rotating disk (HDD). For testing purposes, you can emulate a similar configuration by using HyperV. In that case, one virtual disk file should reside on an SSD, whereas the other should reside on a classical rotating disk.

First, you need to open an administrative Windows PowerShell by right-clicking the Start menu icon and selecting **Windows PowerShell (Admin)**. Verify that the system has already identified the type of the installed disks:

```
PS C:\> Get-PhysicalDisk | FT DeviceId, FriendlyName, UniqueID, Size, MediaType, CanPool
```

DeviceId	FriendlyName	UniqueID	Size	MediaType	CanPool
2	Samsung SSD 960 EVO 1TB	eui.0025385C61B074F7	1000204886016	SSD	False
0	Micron 1100 SATA 512GB	500A071516EBA521	512110190592	SSD	True
1	TOSHIBA DT01ACA200	500003F9E5D69494	2000398934016	HDD	True

In the preceding example, the system has already identified two SSDs and one classical rotating hard disk. You should verify that your empty disks have the *CanPool* value set to *True*. Otherwise, it means that the disk contains valid partitions that need to be deleted. If you're testing a virtualized environment, often the system is not able to correctly identify the media type of the underlying disk.

```
PS C:\> Get-PhysicalDisk | FT DeviceId, FriendlyName, UniqueID, Size, MediaType, CanPool
```

DeviceId	FriendlyName	UniqueID	Size	MediaType	CanPool
2	Msft Virtual Disk	600224802F4EE1E6B94595687DDE774B	137438953472	Unspecified	True
1	Msft Virtual Disk	60022480170766A9A808A30797285D77	1099511627776	Unspecified	True
0	Msft Virtual Disk	6002248048976A586FE149B00A43FC73	274877906944	Unspecified	False

In this case, you should manually specify the type of disk by using the command **Set-PhysicalDisk -UniqueId (Get-PhysicalDisk)[<IDX>].UniqueId -MediaType <Type>**, where *IDX* is the row number in the previous output and *MediaType* is SSD or HDD, depending on the disk type. For example:

```
PS C:\> Set-PhysicalDisk -UniqueId (Get-PhysicalDisk)[0].UniqueId -MediaType SSD
PS C:\> Set-PhysicalDisk -UniqueId (Get-PhysicalDisk)[1].UniqueId -MediaType HDD
PS C:\> Get-PhysicalDisk | FT DeviceId, FriendlyName, UniqueID, Size, MediaType, CanPool
```

DeviceId	FriendlyName	UniqueID	Size	MediaType	CanPool
2	Msft Virtual Disk	600224802F4EE1E6B94595687DDE774B	137438953472	SSD	True
1	Msft Virtual Disk	60022480170766A9A808A30797285D77	1099511627776	HDD	True
0	Msft Virtual Disk	6002248048976A586FE149B00A43FC73	274877906944	Unspecified	False

At this stage you need to create the Storage pool, which is going to contain all the physical disks that are going to compose the new virtual disk. You will then create the storage tiers. In this example, we named the Storage Pool as DefaultPool:

```
PS C:\> New-StoragePool -StorageSubSystemId (Get-StorageSubSystem).UniqueId -FriendlyName DefaultPool -PhysicalDisks (Get-PhysicalDisk -CanPool $true)
```

FriendlyName	OperationalStatus	HealthStatus	IsPrimordial	IsReadOnly	Size	AllocatedSize
Pool	OK	Healthy	False		1.12 TB	512 MB

```
PS C:\> Get-StoragePool DefaultPool | New-StorageTier -FriendlyName SSD -MediaType SSD
...
```

```
PS C:\> Get-StoragePool DefaultPool | New-StorageTier -FriendlyName HDD -MediaType HDD
...
```

Finally, we can create the virtual tiered volume by assigning it a name and specifying the correct size of each tier. In this example, we create a tiered volume named TieredVirtualDisk composed of a 120-GB performance tier and a 1,000-GB capacity tier:

```
PS C:\> $SSD = Get-StorageTier -FriendlyName SSD
PS C:\> $HDD = Get-StorageTier -FriendlyName HDD
```

```
PS C:\> Get-StoragePool Pool | New-VirtualDisk -FriendlyName "TieredVirtualDisk"
-ResiliencySettingName "Simple" -StorageTiers $SSD, $HDD -StorageTierSizes 128GB, 1000GB
...
```

```
PS C:\> Get-VirtualDisk | FT FriendlyName, OperationalStatus, HealthStatus, Size,
FootprintOnPool
```

FriendlyName	OperationalStatus	HealthStatus	Size	FootprintOnPool
TieredVirtualDisk	OK	Healthy	1202590842880	1203664584704

After the virtual disk is created, you need to create the partitions and format the new volume through standard means (such as by using the Disk Management snap-in or the Format tool). After you complete volume formatting, you can verify whether the resulting volume is really a tiered volume by using the fsutil.exe tool:

```
PS E:\> fsutil tiering regionList e:
Total Number of Regions for this volume: 2
Total Number of Regions returned by this operation: 2
```

```
Region # 0:
Tier ID: {448ABAB8-F00B-42D6-B345-C8DA68869020}
Name: TieredVirtualDisk-SSD
Offset: 0x0000000000000000
Length: 0x0000001dff000000
```

```
Region # 1:
Tier ID: {16A7BB83-CE3E-4996-8FF3-BEE98B68EBE4}
Name: TieredVirtualDisk-HDD
Offset: 0x0000001dff000000
Length: 0x000000f9ffe00000
```

Conclusion

Windows supports a wide variety of file system formats accessible to both the local system and remote clients. The file system filter driver architecture provides a clean way to extend and augment file system access, and both NTFS and ReFS provide a reliable, secure, scalable file system format for local file system storage. Although ReFS is a relatively new file system, and implements some advanced features designed for big server environments, NTFS was also updated with support for new device types and new features (like the POSIX delete, online checkdisk, and encryption).

The cache manager provides a high-speed, intelligent mechanism for reducing disk I/O and increasing overall system throughput. By caching on the basis of virtual blocks, the cache manager can perform intelligent read-ahead, including on remote, networked file systems. By relying on the global memory manager's mapped file primitive to access file data, the cache manager can provide a special fast I/O mechanism to reduce the CPU time required for read and write operations, while also leaving all matters related to physical memory management to the Windows memory manager, thus reducing code duplication and increasing efficiency.

Through DAX and PM disk support, storage spaces and storage spaces direct, tiered volumes, and SMR disk compatibility, Windows continues to be at the forefront of next-generation storage architectures designed for high availability, reliability, performance, and cloud-level scale.

In the next chapter, we look at startup and shutdown in Windows.

Startup and shutdown

In this chapter, we describe the steps required to boot Windows and the options that can affect system startup. Understanding the details of the boot process will help you diagnose problems that can arise during a boot. We discuss the details of the new UEFI firmware, and the improvements brought by it compared to the old historical BIOS. We present the role of the Boot Manager, Windows Loader, NT kernel, and all the components involved in standard boots and in the new Secure Launch process, which detects any kind of attack on the boot sequence. Then we explain the kinds of things that can go wrong during the boot process and how to resolve them. Finally, we explain what occurs during an orderly system shutdown.

Boot process

In describing the Windows boot process, we start with the installation of Windows and proceed through the execution of boot support files. Device drivers are a crucial part of the boot process, so we explain how they control the point in the boot process at which they load and initialize. Then we describe how the executive subsystems initialize and how the kernel launches the user-mode portion of Windows by starting the Session Manager process (`Smss.exe`), which starts the initial two sessions (session 0 and session 1). Along the way, we highlight the points at which various on-screen messages appear to help you correlate the internal process with what you see when you watch Windows boot.

The early phases of the boot process differ significantly on systems with an Extensible Firmware Interface (EFI) versus the old systems with a BIOS (basic input/output system). EFI is a newer standard that does away with much of the legacy 16-bit code that BIOS systems use and allows the loading of preboot programs and drivers to support the operating system loading phase. EFI 2.0, which is known as Unified EFI, or UEFI, is used by the vast majority of machine manufacturers. The next sections describe the portion of the boot process specific to UEFI-based machines.

To support these different firmware implementations, Windows provides a boot architecture that abstracts many of the differences away from users and developers to provide a consistent environment and experience regardless of the type of firmware used on the installed system.

The UEFI boot

The Windows boot process doesn't begin when you power on your computer or press the reset button. It begins when you install Windows on your computer. At some point during the execution of the Windows Setup program, the system's primary hard disk is prepared in a way that both the Windows

Boot Manager and the UEFI firmware can understand. Before we get into what the Windows Boot Manager code does, let's have a quick look at the UEFI platform interface.

The UEFI is a set of software that provides the first basic programmatic interface to the platform. With the term *platform*, we refer to the motherboard, chipset, central processing unit (CPU), and other components that compose the machine "engine." As Figure 12-1 shows, the UEFI specifications provide four basic services that run in most of the available CPU architectures (x86, ARM, and so on). We use the x86-64 architecture for this quick introduction:

- **Power on** When the platform is powered on, the UEFI Security Phase handles the platform restart event, verifies the Pre EFI Initialization modules' code, and switches the processor from 16-bit real mode to 32-bit flat mode (still no paging support).
- **Platform initialization** The Pre EFI Initialization (PEI) phase initializes the CPU, the UEFI core's code, and the chipset and finally passes the control to the Driver Execution Environment (DXE) phase. The DXE phase is the first code that runs entirely in full 64-bit mode. Indeed, the last PEI module, called DXE IPL, switches the execution mode to 64-bit long mode. This phase searches inside the firmware volume (stored in the system SPI flash chip) and executes each peripheral's startup drivers (called DXE drivers). Secure Boot, an important security feature that we talk about later in this chapter in the "Secure Boot" section, is implemented as a UEFI DXE driver.
- **OS boot** After the UEFI DXE phase ends, execution control is handed to the Boot Device Selection (BDS) phase. This phase is responsible for implementing the UEFI Boot Loader. The UEFI BDS phase locates and executes the Windows UEFI Boot Manager that the Setup program has installed.
- **Shutdown** The UEFI firmware implements some runtime services (available even to the OS) that help in powering off the platform. Windows doesn't normally make use of these functions (relying instead on the ACPI interfaces).

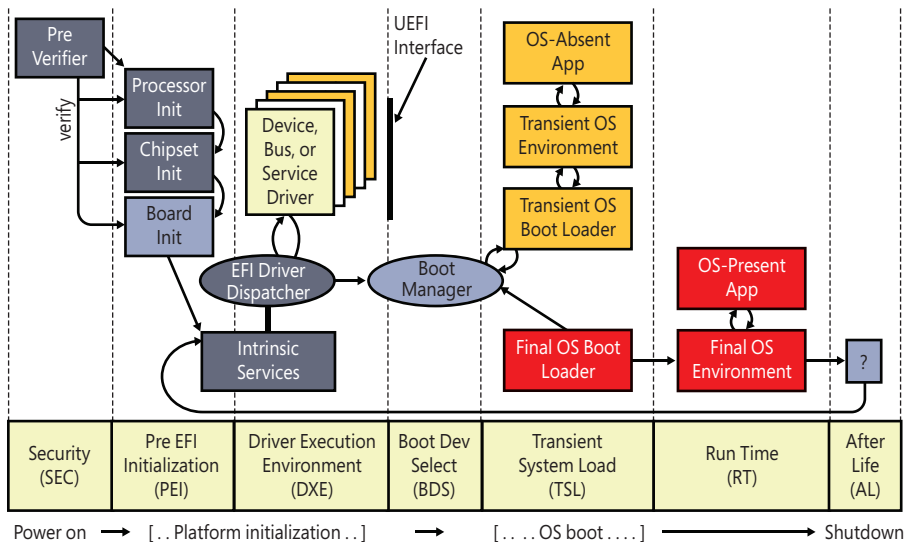

FIGURE 12-1 The UEFI framework.

Describing the entire UEFI framework is beyond the scope of this book. After the UEFI BDS phase ends, the firmware still owns the platform, making available the following services to the OS boot loader:

- **Boot services** Provide basic functionality to the boot loader and other EFI applications, such as basic memory management, synchronization, textual and graphical console I/O, and disk and file I/O. Boot services implement some routines able to enumerate and query the installed “protocols” (EFI interfaces). These kinds of services are available only while the firmware owns the platform and are discarded from memory after the boot loader has called the *ExitBootServices* EFI runtime API.
- **Runtime services** Provide date and time services, capsule update (firmware upgrading), and methods able to access NVRAM data (such as UEFI variables). These services are still accessible while the operating system is fully running.
- **Platform configuration data** System ACPI and SMBIOS tables are always accessible through the UEFI framework.

The UEFI Boot Manager can read and write from computer hard disks and understands basic file systems like FAT, FAT32, and El Torito (for booting from a CD-ROM). The specifications require that the boot hard disk be partitioned through the GPT (GUID partition table) scheme, which uses GUIDs to identify different partitions and their roles in the system. The GPT scheme overcomes all the limitations of the old MBR scheme and allows a maximum of 128 partitions, using a 64-bit LBA addressing mode (resulting in a huge partition size support). Each partition is identified using a unique 128-bit GUID value. Another GUID is used to identify the partition type. While UEFI defines only three partition types, each OS vendor defines its own partition’s GUID types. The UEFI standard requires at least one EFI system partition, formatted with a FAT32 file system.

The Windows Setup application initializes the disk and usually creates at least four partitions:

- The EFI system partition, where it copies the Windows Boot Manager (*Bootmgrfw.efi*), the memory test application (*Memtest.efi*), the system lockdown policies (for Device Guard-enabled systems, *Winsipolicy.p7b*), and the boot resource file (*Bootres.dll*).
- A recovery partition, where it stores the files needed to boot the Windows Recovery environment in case of startup problems (*boot.sdi* and *Winre.wim*). This partition is formatted using the NTFS file system.
- A Windows reserved partition, which the Setup tool uses as a fast, recoverable scratch area for storing temporary data. Furthermore, some system tools use the Reserved partition for remapping damaged sectors in the boot volume. (The reserved partition does not contain any file system.)
- A boot partition—which is the partition on which Windows is installed and is not typically the same as the system partition—where the boot files are located. This partition is formatted using NTFS, the only supported file system that Windows can boot from when installed on a fixed disk.

The Windows Setup program, after placing the Windows files on the boot partition, copies the boot manager in the EFI system partition and hides the boot partition content for the rest of the system. The UEFI specification defines some global variables that can reside in NVRAM (the system’s nonvolatile RAM) and are accessible even in the runtime phase when the OS has gained full control of the platform

(some other UEFI variables can even reside in the system RAM). The Windows Setup program configures the UEFI platform for booting the Windows Boot Manager through the settings of some UEFI variables (Boot000X one, where X is a unique number, depending on the boot load-option number, and BootOrder). When the system reboots after setup ends, the UEFI Boot Manager is automatically able to execute the Windows Boot Manager code.

Table 12-1 summarizes the files involved in the UEFI boot process. Figure 12-2 shows an example of a hard disk layout, which follows the GPT partition scheme. (Files located in the Windows boot partition are stored in the \Windows\System32 directory.)

TABLE 12-1 UEFI boot process components

Component	Responsibilities	Location
bootmgfw.efi	Reads the Boot Configuration Database (BCD), if required, presents boot menu, and allows execution of preboot programs such as the Memory Test application (Memtest.efi).	EFI system partition
Winload.efi	Loads Ntoskrnl.exe and its dependencies (SiPolicy.p7b, hvloader.dll, hvix64.exe, Hal.dll, Kdcom.dll, Ci.dll, Clfs.sys, Pshed.dll) and bootstart device drivers.	Windows boot partition
Winresume.efi	If resuming after a hibernation state, resumes from the hibernation file (Hiberfil.sys) instead of typical Windows loading.	Windows boot partition
Memtest.efi	If selected from the Boot Immersive Menu (or from the Boot Manager), starts up and provides a graphical interface for scanning memory and detecting damaged RAM.	EFI system partition
Hvloader.dll	If detected by the boot manager and properly enabled, this module is the hypervisor launcher (hvloader.efi in the previous Windows version).	Windows boot partition
Hvix64.exe (or hvax64.exe)	The Windows Hypervisor (Hyper-V). Depending on the processor architecture, this file could have different names. It's the basic component for Virtualization Based Security (VBS).	Windows boot partition
Ntoskrnl.exe	Initializes executive subsystems and boot and system-start device drivers, prepares the system for running native applications, and runs Smss.exe.	Windows boot partition
Securekernel.exe	The Windows Secure Kernel. Provides the kernel mode services for the secure VTL 1 World, and some basic communication facility with the normal world (see Chapter 9, "Virtualization Technologies").	Windows boot partition
Hal.dll	Kernel-mode DLL that interfaces Ntoskrnl and drivers to the hardware. It also acts as a driver for the motherboard, supporting soldered components that are not otherwise managed by another driver.	Windows boot partition
Smss.exe	Initial instance starts a copy of itself to initialize each session. The session 0 instance loads the Windows subsystem driver (Win32k.sys) and starts the Windows subsystem process (Csrss.exe) and Windows initialization process (Wininit.exe). All other per-session instances start a Csrss and Winlogon process.	Windows boot partition
Wininit.exe	Starts the service control manager (SCM), the Local Security Authority process (LSASS), and the local session manager (LSM). Initializes the rest of the registry and performs usermode initialization tasks.	Windows boot partition
Winlogon.exe	Coordinates log-on and user security; launches Bootim and LogonUI.	Windows boot partition

Component	Responsibilities	Location
Logonui.exe	Presents interactive log on dialog screen.	Windows boot partition
Bootim.exe	Presents the graphical interactive boot menu.	Windows boot partition
Services.exe	Loads and initializes auto-start device drivers and Windows services.	Windows boot partition
TcbLaunch.exe	Orchestrates the Secure Launch of the operating system in a system that supports the new Intel TXT technology.	Windows boot partition
TcbLoader.dll	Contains the Windows Loader code that runs in the context of the Secure Launch.	Windows boot partition

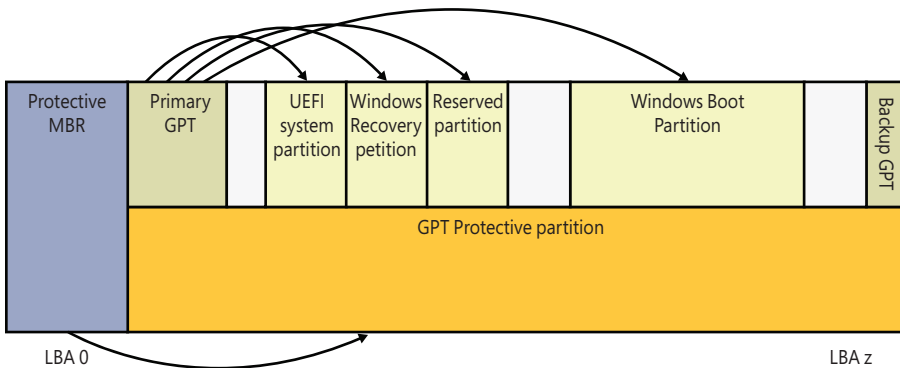

FIGURE 12-2 Sample UEFI hard disk layout.

Another of Setup's roles is to prepare the BCD, which on UEFI systems is stored in the `\EFI\Microsoft\Boot\BCD` file on the root directory of the system volume. This file contains options for starting the version of Windows that Setup installs and any preexisting Windows installations. If the BCD already exists, the Setup program simply adds new entries relevant to the new installation. For more information on the BCD, see Chapter 10, "Management, diagnostics, and tracing."

All the UEFI specifications, which include the PEI and BDS phase, secure boot, and many other concepts, are available at <https://uefi.org/specifications>.

The BIOS boot process

Due to space issues, we don't cover the old BIOS boot process in this edition of the book. The complete description of the BIOS preboot and boot process is in Part 2 of the previous edition of the book.

Secure Boot

As described in Chapter 7 of Part 1, Windows was designed to protect against malware. All the old BIOS systems were vulnerable to Advanced Persistent Threats (APT) that were using a bootkit to achieve stealth and code execution. The bootkit is a particular type of malicious software that runs before the Windows Boot Manager and allows the main infection module to run without being detected by

antivirus solutions. Initial parts of the BIOS bootkit normally reside in the Master Boot Record (MBR) or Volume Boot Record (VBR) sector of the system hard disk. In this way, the old BIOS systems, when switched on, execute the bootkit code instead of the main OS code. The OS original boot code is encrypted and stored in other areas of the hard disk and is usually executed in a later stage by the malicious code. This type of bootkit was even able to modify the OS code in memory during any Windows boot phase.

As demonstrated by security researchers, the first releases of the UEFI specification were still vulnerable to this problem because the firmware, bootloader, and other components were not verified. So, an attacker that has access to the machine could tamper with these components and replace the bootloader with a malicious one. Indeed, any EFI application (executable files that follow the portable executable or terse executable file format) correctly registered in the relative boot variable could have been used for booting the system. Furthermore, even the DXE drivers were not correctly verified, allowing the injection of a malicious EFI driver in the SPI flash. Windows couldn't correctly identify the alteration of the boot process.

This problem led the UEFI consortium to design and develop the secure boot technology. Secure Boot is a feature of UEFI that ensures that each component loaded during the boot process is digitally signed and validated. Secure Boot makes sure that the PC boots using only software that is trusted by the PC manufacturer or the user. In Secure Boot, the firmware is responsible for the verification of all the components (DXE drivers, UEFI boot managers, loaders, and so on) before they are loaded. If a component doesn't pass the validation, an error message is shown to the user and the boot process is aborted.

The verification is performed through the use of public key algorithms (like RSA) for digital signing, against a database of accepted and refused certificates (or hashes) present in the UEFI firmware. In these kind of algorithms, two different keys are employed:

- A public key is used to *decrypt* an encrypted digest (a digest is a hash of the executable file binary data). This key is stored in the digital signature of the file.
- The private key is used to *encrypt* the hash of the binary executable file and is stored in a secure and secret location. The digital signing of an executable file consists of three phases:
 1. Calculate the digest of the file content using a strong hashing algorithm, like SHA256. A strong "hashing" should produce a message digest that is a unique (and relatively small) representation of the complete initial data (a bit like a sophisticated checksum). Hashing algorithms are a one-way encryption—that is, it's impossible to derive the whole file from the digest.
 2. Encrypt the calculated digest with the private portion of the key.
 3. Store the encrypted digest, the public portion of the key, and the name of the hashing algorithm in the digital signature of the file.

In this way, when the system wants to verify and validate the integrity of the file, it recalculates the file hash and compares it against the digest, which has been decrypted from the digital signature. Nobody except the owner of the private key can modify or alter the encrypted digest stored into the digital signature.

This simplified model can be extended to create a chain of certificates, each one trusted by the firmware. Indeed, if a public key located in a specific certificate is unknown by the firmware, but the certificate is signed another time by a trusted entity (an intermediate or root certificate), the firmware could assume that even the inner public key must be considered trusted. This mechanism is shown in Figure 12-3 and is called the *chain of trust*. It relies on the fact that a digital certificate (used for code signing) can be signed using the public key of another trusted higher-level certificate (a root or intermediate certificate). The model is simplified here because a complete description of all the details is outside the scope of this book.

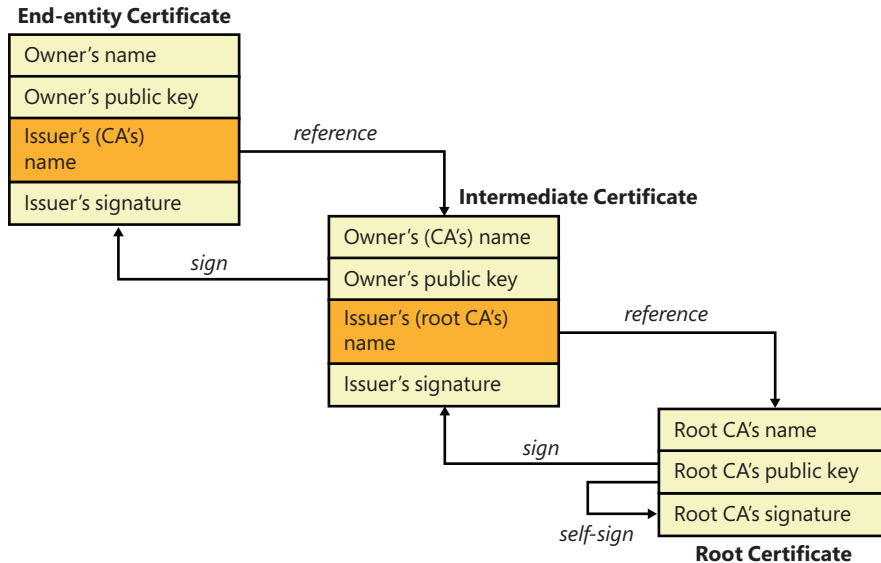

FIGURE 12-3 A simplified representation of the chain of trust.

The allowed/revoked UEFI certificates and hashes have to establish some hierarchy of trust by using the entities shown in Figure 12-4, which are stored in UEFI variables:

- **Platform key (PK)** The platform key represents the root of trust and is used to protect the key exchange key (KEK) database. The platform vendor puts the public portion of the PK into UEFI firmware during manufacturing. Its private portion stays with the vendor.
- **Key exchange key (KEK)** The key exchange key database contains trusted certificates that are allowed to modify the allowed signature database (DB), disallowed signature database (DBX), or timestamp signature database (DBT). The KEK database usually contains certificates of the operating system vendor (OSV) and is secured by the PK.

Hashes and signatures used to verify bootloaders and other pre-boot components are stored in three different databases. The allowed signature database (DB) contains hashes of specific binaries or certificates (or their hashes) that were used to generate code-signing certificates that have signed bootloader and other preboot components (following the chain of trust model). The disallowed signature database (DBX) contains the hashes of specific binaries or certificates (or their hashes) that were

compromised and/or revoked. The timestamp signature database (DBT) contains timestamping certificates used when signing bootloader images. All three databases are locked from editing by the KEK.

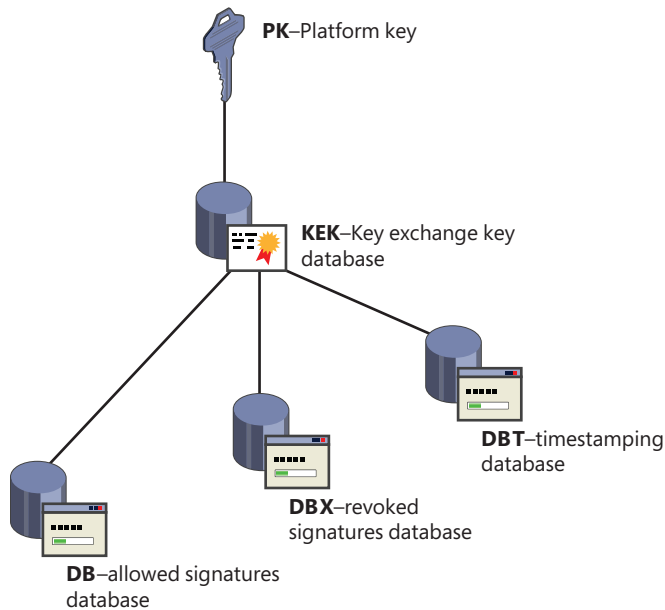

FIGURE 12-4 The certificate the chain of trust used in the UEFI Secure Boot.

To properly seal Secure Boot keys, the firmware should not allow their update unless the entity attempting the update can prove (with a digital signature on a specified payload, called the *authentication descriptor*) that they possess the private part of the key used to create the variable. This mechanism is implemented in UEFI through the Authenticated Variables. At the time of this writing, the UEFI specifications allow only two types of signing keys: X509 and RSA2048. An Authenticated Variable may be cleared by writing an empty update, which must still contain a valid authentication descriptor. When an Authenticated Variable is first created, it stores both the public portion of the key that created it and the initial value for the time (or a monotonic count) and will accept only subsequent updates signed with that key and which have the same update type. For example, the KEK variable is created using the PK and can be updated only by an authentication descriptor signed with the PK.



Note The way in which the UEFI firmware uses the Authenticated Variables in Secure Boot environments could lead to some confusion. Indeed, only the PK, KEK, and signatures databases are stored using Authenticated Variables. The other UEFI boot variables, which store boot configuration data, are still regular runtime variables. This means that in a Secure Boot environment, a user is still able to update or change the boot configuration (modifying even the boot order) without any problem. This is not an issue, because the secure verification is always made on every kind of boot application (regardless of its source or order). Secure Boot is not designed to prevent the modification of the system boot configuration.

The Windows Boot Manager

As discussed previously, the UEFI firmware reads and executes the Windows Boot Manager (Bootmgfw.efi). The EFI firmware transfers control to Bootmgr in long mode with paging enabled, and the memory space defined by the UEFI memory map is mapped one to one. So, unlike wBIOS systems, there's no need to switch execution context. The Windows Boot Manager is indeed the first application that's invoked when starting or resuming the Windows OS from a completely off power state or from hibernation (S4 power state). The Windows Boot Manager has been completely redesigned starting from Windows Vista, with the following goals:

- Support the boot of different operating systems that employ complex and various boot technologies.
- Separate the OS-specific startup code in its own boot application (named Windows Loader) and the Resume application (Winresume).
- Isolate and provide common boot services to the boot applications. This is the role of the boot libraries.

Even though the final goal of the Windows Boot Manager seems obvious, its entire architecture is complex. From now on, we use the term *boot application* to refer to any OS loader, such as the Windows Loader and other loaders. Bootmgr has multiple roles, such as the following:

- Initializes the boot logger and the basic system services needed for the boot application (which will be discussed later in this section)
- Initializes security features like Secure Boot and Measured Boot, loads their system policies, and verifies its own integrity
- Locates, opens, and reads the Boot Configuration Data store
- Creates a “boot list” and shows a basic boot menu (if the boot menu policy is set to Legacy)
- Manages the TPM and the unlock of BitLocker-encrypted drives (showing the BitLocker unlock screen and providing a recovery method in case of problems getting the decryption key)
- Launches a specific boot application and manages the recovery sequence in case the boot has failed (Windows Recovery Environment)

One of the first things performed is the configuration of the boot logging facility and initialization of the boot libraries. Boot applications include a standard set of libraries that are initialized at the start of the Boot Manager. Once the standard boot libraries are initialized, then their core services are available to all boot applications. These services include a basic memory manager (that supports address translation, and page and heap allocation), firmware parameters (like the boot device and the boot manager entry in the BCD), an event notification system (for Measured Boot), time, boot logger, crypto modules, the Trusted Platform Module (TPM), network, display driver, and I/O system (and a basic PE Loader). The reader can imagine the boot libraries as a special kind of basic hardware abstraction layer (HAL) for the Boot Manager and boot applications. In the early stages of library initialization, the System Integrity boot library component is initialized. The goal of the System Integrity service is to provide a platform for reporting and recording security-relevant system events, such as loading of new code, attaching a

debugger, and so on. This is achieved using functionality provided by the TPM and is used especially for Measured Boot. We describe this feature later in the chapter in the “Measured Boot” section.

To properly execute, the Boot Manager initialization function (*BmMain*) needs a data structure called Application Parameters that, as the name implies, describes its startup parameters (like the Boot Device, BCD object GUID, and so on). To compile this data structure, the Boot Manager uses the EFI firmware services with the goal of obtaining the complete relative path of its own executable and getting the startup load options stored in the active EFI boot variable (BOOT000X). The EFI specifications dictate that an EFI boot variable must contain a short description of the boot entry, the complete device and file path of the Boot Manager, and some optional data. Windows uses the optional data to store the GUID of the BCD object that describes itself.



Note The optional data could include any other boot options, which the Boot Manager will parse at later stages. This allows the configuration of the Boot Manager from UEFI variables without using the Windows Registry at all.

EXPERIMENT: Playing with the UEFI boot variables

You can use the UefiTool utility (found in this book’s downloadable resources) to dump all the UEFI boot variables of your system. To do so, just run the tool in an administrative command prompt and specify the **/enum** command-line parameter. (You can launch the command prompt as administrator by searching *cmd* in the Cortana search box and selecting **Run As Administrator** after right-clicking **Command Prompt**.) A regular system uses a lot of UEFI variables. The tool supports filtering all the variables by name and GUID. You can even export all the variable names and data in a text file using the **/out** parameter.

Start by dumping all the UEFI variables in a text file:

```
C:\Tools>UefiTool.exe /enum /out Uefi_Variables.txt
UEFI Dump Tool v0.1
Copyright 2018 by Andrea Allievi (AaL186)
```

```
Firmware type: UEFI
Bitlocker enabled for System Volume: NO
```

Successfully written “Uefi_Variables.txt” file.

You can get the list of UEFI boot variables by using the following filter:

```
C:\Tools>UefiTool.exe /enum Boot
UEFI Dump Tool v0.1
Copyright 2018 by Andrea Allievi (AaL186)
```

```
Firmware type: UEFI
Bitlocker enabled for System Volume: NO
```

```

EFI Variable "BootCurrent"
  Guid       : {8BE4DF61-93CA-11D2-AA0D-00E098032B8C}
  Attributes: 0x06 ( BS RT )
  Data size : 2 bytes
  Data:
  00 00 |

EFI Variable "Boot0002"
  Guid       : {8BE4DF61-93CA-11D2-AA0D-00E098032B8C}
  Attributes: 0x07 ( NV BS RT )
  Data size : 78 bytes
  Data:
  01 00 00 00 2C 00 55 00 53 00 42 00 20 00 53 00 |   , U S B   S
  74 00 6F 00 72 00 61 00 67 00 65 00 00 00 04 07 | t o r a g e
  14 00 67 D5 81 A8 B0 6C EE 4E 84 35 2E 72 D3 3E | g ü ĺ l Nâ5.r >
  45 B5 04 06 14 00 71 00 67 50 8F 47 E7 4B AD 13 | E q gPÄG Kj
  87 54 F3 79 C6 2F 7F FF 04 00 55 53 42 00   | çT≤y / USB

EFI Variable "Boot0000"
  Guid       : {8BE4DF61-93CA-11D2-AA0D-00E098032B8C}
  Attributes: 0x07 ( NV BS RT )
  Data size : 300 bytes
  Data:
  01 00 00 00 74 00 57 00 69 00 6E 00 64 00 6F 00 |   t W I n d o
  77 00 73 00 20 00 42 00 6F 00 6F 00 74 00 20 00 | w s   B o o t
  4D 00 61 00 6E 00 61 00 67 00 65 00 72 00 00 00 | M a n a g e r
  04 01 2A 00 02 00 00 00 00 A0 0F 00 00 00 00 00 | * á
  00 98 0F 00 00 00 00 00 84 C4 AF 4D 52 3B 80 44 | ý   ä »MR;ÇD
  98 DF 2C A4 93 AB 30 B0 02 02 04 04 46 00 5C 00 | ý ,ñô%0 F \
  45 00 46 00 49 00 5C 00 4D 00 69 00 63 00 72 00 | E F I \ M i c r
  6F 00 73 00 6F 00 66 00 74 00 5C 00 42 00 6F 00 | o s o f t \ B o
  6F 00 74 00 5C 00 62 00 6F 00 6F 00 74 00 6D 00 | o t \ b o o t m
  67 00 66 00 77 00 2E 00 65 00 66 00 69 00 00 00 | g f w . e f i
  7F FF 04 00 57 49 4E 44 4F 57 53 00 01 00 00 00 |   W I N D O W S
  88 00 00 00 78 00 00 00 42 00 43 00 44 00 4F 00 | ê   x   B C D O
  42 00 4A 00 45 00 43 00 54 00 3D 00 7B 00 39 00 | B J E C T = { 9
  64 00 65 00 61 00 38 00 36 00 32 00 63 00 2D 00 | d e a 8 6 2 c -
  35 00 63 00 64 00 64 00 2D 00 34 00 65 00 37 00 | 5 c d d - 4 e 7
  30 00 2D 00 61 00 63 00 63 00 31 00 2D 00 66 00 | 0 - a c c 1 - f
  33 00 32 00 62 00 33 00 34 00 34 00 64 00 34 00 | 3 2 b 3 4 4 d 4
  37 00 39 00 35 00 7D 00 00 00 6F 00 01 00 00 00 | 7 9 5 }   o
  10 00 00 00 04 00 00 00 7F FF 04 00   |

EFI Variable "BootOrder"
  Guid       : {8BE4DF61-93CA-11D2-AA0D-00E098032B8C}
  Attributes: 0x07 ( NV BS RT )
  Data size : 8 bytes
  Data:
  02 00 00 00 01 00 03 00 |

```

<Full output cut for space reasons>

The tool can even interpret the content of each boot variable. You can launch it using the **/enumboot** parameter:

```
C:\Tools>UefiTool.exe /enumboot
UEFI Dump Tool v0.1
Copyright 2018 by Andrea Allievi (AaL186)
```

```
Firmware type: UEFI
Bitlocker enabled for System Volume: NO
```

```
System Boot Configuration
  Number of the Boot entries: 4
  Current active entry: 0
  Order: 2, 0, 1, 3
```

```
Boot Entry #2
  Type: Active
  Description: USB Storage
```

```
Boot Entry #0
  Type: Active
  Description: Windows Boot Manager
  Path: Harddisk0\Partition2 [LBA: 0xFA000]\\EFI\Microsoft\Boot\bootmgfw.efi
  OS Boot Options: BCDOBJECT={9dea862c-5cdd-4e70-acc1-f32b344d4795}
```

```
Boot Entry #1
  Type: Active
  Description: Internal Storage
```

```
Boot Entry #3
  Type: Active
  Description: PXE Network
```

When the tool is able to parse the boot path, it prints the relative *Path* line (the same applies for the Winload OS load options). The UEFI specifications define different interpretations for the path field of a boot entry, which are dependent on the hardware interface. You can change your system boot order by simply setting the value of the `BootOrder` variable, or by using the **/setbootorder** command-line parameter. Keep in mind that this could invalidate the BitLocker Volume master key. (We explain this concept later in this chapter in the “Measured Boot” section):

```
C:\Tools>UefiTool.exe /setvar bootorder {8BE4DF61-93CA-11D2-AA0D-00E098032B8C}
0300020000000100
UEFI Dump Tool v0.1
Copyright 2018 by Andrea Allievi (AaL186)
```

```
Firmware type: UEFI
Bitlocker enabled for System Volume: YES
```

```
Warning, The "bootorder" firmware variable already exist.
Overwriting it could potentially invalidate the system Bitlocker Volume Master Key.
Make sure that you have made a copy of the System volume Recovery Key.
Are you really sure that you would like to continue and overwrite its content? [Y/N] y
The "bootorder" firmware variable has been successfully written.
```

After the Application Parameters data structure has been built and all the boot paths retrieved (\EFI\Microsoft\Boot is the main working directory), the Boot Manager opens and parses the Boot Configuration Data file. This file internally is a registry hive that contains all the boot application descriptors and is usually mapped in an HKLM\BCD00000000 virtual key after the system has completely started. The Boot Manager uses the boot library to open and read the BCD file. The library uses EFI services to read and write physical sectors from the hard disk and, at the time of this writing, implements a light version of various file systems, such as NTFS, FAT, ExFAT, UDFS, El Torito, and virtual file systems that support Network Boot I/O, VMBus I/O (for Hyper-V virtual machines), and WIM images I/O. The Boot Configuration Data hive is parsed, the BCD object that describes the Boot Manager is located (through its GUID), and all the entries that represent boot arguments are added to the startup section of the Application Parameters data structure. Entries in the BCD can include optional arguments that Bootmgr, Winload, and other components involved in the boot process interpret. Table 12-2 contains a list of these options and their effects for Bootmgr, Table 12-3 shows a list of BCD options available to all boot applications, and Table 12-4 shows BCD options for the Windows boot loader. Table 12-5 shows BCD options that control the execution of the Windows Hypervisor.

TABLE 12-2 BCD options for the Windows Boot Manager (Bootmgr)

Readable name	Values	BCD Element Code ¹	Meaning
bcdfilepath	Path	BCD_FILEPATH	Points to the BCD (usually \Boot\BCD) file on the disk.
displaybootmenu	Boolean	DISPLAY_BOOT_MENU	Determines whether the Boot Manager shows the boot menu or picks the default entry automatically.
noerrordisplay	Boolean	NO_ERROR_DISPLAY	Silences the output of errors encountered by the Boot Manager.
resume	Boolean	ATTEMPT_RESUME	Specifies whether resuming from hibernation should be attempted. This option is automatically set when Windows hibernates.
timeout	Seconds	TIMEOUT	Number of seconds that the Boot Manager should wait before choosing the default entry.
resumeobject	GUID	RESUME_OBJECT	Identifier for which boot application should be used to resume the system after hibernation.
displayorder	List	DISPLAY_ORDER	Definition of the Boot Manager's display order list.
toolsdisplayorder	List	TOOLS_DISPLAY_ORDER	Definition of the Boot Manager's tool display order list.
bootsequence	List	BOOT_SEQUENCE	Definition of the one-time boot sequence.
default	GUID	DEFAULT_OBJECT	The default boot entry to launch.
customactions	List	CUSTOM_ACTIONS_LIST	Definition of custom actions to take when a specific keyboard sequence has been entered.
processcustomactions-first	Boolean	PROCESS_CUSTOM_ACTIONS_FIRST	Specifies whether the Boot Manager should run custom actions prior to the boot sequence.
bcddevice	GUID	BCD_DEVICE	Device ID of where the BCD store is located.

Readable name	Values	BCD Element Code ¹	Meaning
hiberboot	Boolean	HIBERBOOT	Indicates whether this boot was a hybrid boot.
fvrecoveryurl	String	FVE_RECOVERY_URL	Specifies the BitLocker recovery URL string.
fvrecoverymessage	String	FVE_RECOVERY_MESSAGE	Specifies the BitLocker recovery message string.
flightedbootmgr	Boolean	BOOT_FLIGHT_BOOTMGR	Specifies whether execution should proceed through a flighted Bootmgr.

¹ All the Windows Boot Manager BCD element codes start with BCDE_BOOTMGR_TYPE, but that has been omitted due to limited space.

TABLE 12-3 BCD library options for boot applications (valid for all object types)

Readable Name	Values	BCD Element Code ²	Meaning
advancedoptions	Boolean	DISPLAY_ADVANCED_OPTIONS	If false, executes the default behavior of launching the auto-recovery command boot entry when the boot fails; otherwise, displays the boot error and offers the user the advanced boot option menu associated with the boot entry. This is equivalent to pressing F8.
avoidlowmemory	Integer	AVOID_LOW_PHYSICAL_MEMORY	Forces physical addresses below the specified value to be avoided by the boot loader as much as possible. Sometimes required on legacy devices (such as ISA) where only memory below 16 MB is usable or visible.
badmemoryaccess	Boolean	ALLOW_BAD_MEMORY_ACCESS	Forces usage of memory pages in the Bad Page List (see Part 1, Chapter 5, “Memory management,” for more information on the page lists).
badmemorylist	Array of page frame numbers (PFNs)	BAD_MEMORY_LIST	Specifies a list of physical pages on the system that are known to be bad because of faulty RAM.
baudrate	Baud rate in bps	DEBUGGER_BAUDRATE	Specifies an override for the default baud rate (19200) at which a remote kernel debugger host will connect through a serial port.
bootdebug	Boolean	DEBUGGER_ENABLED	Enables remote boot debugging for the boot loader. With this option enabled, you can use Kd.exe or Windbg.exe to connect to the boot loader.
bootems	Boolean	EMS_ENABLED	Causes Windows to enable Emergency Management Services (EMS) for boot applications, which reports boot information and accepts system management commands through a serial port.
busparams	String	DEBUGGER_BUS_PARAMETERS	If a physical PCI debugging device is used to provide kernel debugging, specifies the PCI bus, function, and device number (or the ACPI DBG table index) for the device.
channel	Channel between 0 and 62	DEBUGGER_1394_CHANNEL	Used in conjunction with <debugtype> 1394 to specify the IEEE 1394 channel through which kernel debugging communications will flow.

Readable Name	Values	BCD Element Code ²	Meaning
configaccesspolicy	Default, DisallowMmConfig	CONFIG_ACCESS_POLICY	Configures whether the system uses memory-mapped I/O to access the PCI manufacturer's configuration space or falls back to using the HAL's I/O port access routines. Can sometimes be helpful in solving platform device problems.
debugaddress	Hardware address	DEBUGGER_PORT_ADDRESS	Specifies the hardware address of the serial (COM) port used for debugging.
debugport	COM port number	DEBUGGER_PORT_NUMBER	Specifies an override for the default serial port (usually COM2 on systems with at least two serial ports) to which a remote kernel debugger host is connected.
debugstart	Active, AutoEnable, Disable	DEBUGGER_START_POLICY	Specifies settings for the debugger when kernel debugging is enabled. AutoEnable enables the debugger when a breakpoint or kernel exception, including kernel crashes, occurs.
debugtype	Serial, 1394, USB, or Net	DEBUGGER_TYPE	Specifies whether kernel debugging will be communicated through a serial, FireWire (IEEE 1394), USB, or Ethernet port. (The default is serial.)
hostip	Ip address	DEBUGGER_NET_HOST_IP	Specifies the target IP address to connect to when the kernel debugger is enabled through Ethernet.
port	Integer	DEBUGGER_NET_PORT	Specifies the target port number to connect to when the kernel debugger is enabled through Ethernet.
key	String	DEBUGGER_NET_KEY	Specifies the encryption key used for encrypting debugger packets while using the kernel Debugger through Ethernet.
emsbaudrate	Baud rate in bps	EMS_BAUDRATE	Specifies the baud rate to use for EMS.
emSPORT	COM port number	EMS_PORT_NUMBER	Specifies the serial (COM) port to use for EMS.
extendedinput	Boolean	CONSOLE_EXTENDED_INPUT	Enables boot applications to leverage BIOS support for extended console input.
keyringaddress	Physical address	FVE_KEYRING_ADDRESS	Specifies the physical address where the BitLocker key ring is located.
firstmegabytepolicy	UseNone, UseAll, UsePrivate	FIRST_MEGABYTE_POLICY	Specifies how the low 1 MB of physical memory is consumed by the HAL to mitigate corruptions by the BIOS during power transitions.
fontpath	String	FONT_PATH	Specifies the path of the OEM font that should be used by the boot application.
graphicsmodedisabled	Boolean	GRAPHICS_MODE_DISABLED	Disables graphics mode for boot applications.
graphicsresolution	Resolution	GRAPHICS_RESOLUTION	Sets the graphics resolution for boot applications.
initialconsoleinput	Boolean	INITIAL_CONSOLE_INPUT	Specifies an initial character that the system inserts into the PC/ AT keyboard input buffer.
integrityservices	Default, Disable, Enable	SI_POLICY	Enables or disables code integrity services, which are used by Kernel Mode Code Signing. Default is Enabled.

Readable Name	Values	BCD Element Code ²	Meaning
locale	Localization string	PREFERRED_LOCALE	Sets the locale for the boot application (such as EN-US).
noumex	Boolean	DEBUGGER_IGNORE_USERMODE_EXCEPTIONS	Disables user-mode exceptions when kernel debugging is enabled. If you experience system hangs (freezes) when booting in debugging mode, try enabling this option.
recoveryenabled	Boolean	AUTO_RECOVERY_ENABLED	Enables the recovery sequence, if any. Used by fresh installations of Windows to present the Windows PE-based Startup And Recovery interface.
recoverysequence	List	RECOVERY_SEQUENCE	Defines the recovery sequence (described earlier).
relocatephysical	Physical address	RELOCATE_PHYSICAL_MEMORY	Relocates an automatically selected NUMA node's physical memory to the specified physical address.
targetname	String	DEBUGGER_USB_TARGETNAME	Defines the target name for the USB debugger when used with USB2 or USB3 debugging (debugtype is set to USB).
testsigning	Boolean	ALLOW_PRERELEASE_SIGNATURES	Enables test-signing mode, which allows driver developers to load locally signed 64-bit drivers. This option results in a water-marked desktop.
truncatememory	Address in bytes	TRUNCATE_PHYSICAL_MEMORY	Disregards physical memory above the specified physical address.

2 All the BCD elements codes for Boot Applications start with BCDE_LIBRARY_TYPE, but that has been omitted due to limited space.

TABLE 12-4 BCD options for the Windows OS Loader (Winload)

BCD Element	Values	BCD Element Code ³	Meaning
bootlog	Boolean	LOG_INITIALIZATION	Causes Windows to write a log of the boot to the file %SystemRoot%\Ntbtlog.txt.
bootstatuspolicy	DisplayAllFailures, ignoreAllFailures, IgnoreShutdownFailures, IgnoreBootFailures	BOOT_STATUS_POLICY	Overrides the system's default behavior of offering the user a troubleshooting boot menu if the system didn't complete the previous boot or shutdown.
bootux	Disabled, Basic, Standard	BOOTUX_POLICY	Defines the boot graphics user experience that the user will see. Disabled means that no graphics will be seen during boot time (only a black screen), while Basic will display only a progress bar during load. Standard displays the usual Windows logo animation during boot.
bootmenupolicy	Legacy Standard	BOOT_MENU_POLICY	Specify the type of boot menu to show in case of multiple boot entries (see "The boot menu" section later in this chapter).
clustermodeaddressing	Number of processors	CLUSTERMODE_ADDRESSING	Defines the maximum number of processors to include in a single Advanced Programmable Interrupt Controller (APIC) cluster.
configflags	Flags	PROCESSOR_CONFIGURATION_FLAGS	Specifies processor-specific configuration flags.

BCD Element	Values	BCD Element Code ³	Meaning
dbgtransport	Transport image name	DBG_TRANSPORT_PATH	Overrides using one of the default kernel debugging transports (Kdcom.dll, Kd1394, Kdusb.dll) and instead uses the given file, permitting specialized debugging transports to be used that are not typically supported by Windows.
debug	Boolean	KERNEL_DEBUGGER_ENABLED	Enables kernel-mode debugging.
detecthal	Boolean	DETECT_KERNEL_AND_HAL	Enables the dynamic detection of the HAL.
driverloadfailurepolicy	Fatal, UseErrorControl	DRIVER_LOAD_FAILURE_POLICY	Describes the loader behavior to use when a boot driver has failed to load. Fatal will prevent booting, whereas UseErrorControl causes the system to honor a driver's default error behavior, specified in its service key.
ems	Boolean	KERNEL_EMS_ENABLED	Instructs the kernel to use EMS as well. (If only bootems is used, only the boot loader will use EMS.)
evstore	String	EVSTORE	Stores the location of a boot preloaded hive.
groupaware	Boolean	FORCE_GROUP_AWARENESS	Forces the system to use groups other than zero when associating the group seed to new processes. Used only on 64-bit Windows.
groupsize	Integer	GROUP_SIZE	Forces the maximum number of logical processors that can be part of a group (maximum of 64). Can be used to force groups to be created on a system that would normally not require them to exist. Must be a power of 2 and is used only on 64-bit Windows.
hal	HAL image name	HAL_PATH	Overrides the default file name for the HAL image (Hal.dll). This option can be useful when booting a combination of a checked HAL and checked kernel (requires specifying the kernel element as well).
halbreakpoint	Boolean	DEBUGGER_HAL_BREAKPOINT	Causes the HAL to stop at a breakpoint early in HAL initialization. The first thing the Windows kernel does when it initializes is to initialize the HAL, so this breakpoint is the earliest one possible (unless boot debugging is used). If the switch is used without the /DEBUG switch, the system will present a blue screen with a STOP code of 0x00000078 (<i>PHASE0_EXCEPTION</i>).
novesa	Boolean	BCDE_OSLOADER_TYPE_DISABLE_VESA_BIOS	Disables the usage of VESA display modes.
optionsedit	Boolean	OPTIONS_EDIT_ONE_TIME	Enables the options editor in the Boot Manager. With this option, Boot Manager allows the user to interactively set on-demand command-line options and switches for the current boot. This is equivalent to pressing F10.
osdevice	GUID	OS_DEVICE	Specifies the device on which the operating system is installed.

BCD Element	Values	BCD Element Code ³	Meaning
pae	Default, ForceEnable, ForceDisable	PAE_POLICY	Default allows the boot loader to determine whether the system supports PAE and loads the PAE kernel. ForceEnable forces this behavior, while ForceDisable forces the loader to load the non-PAE version of the Windows kernel, even if the system is detected as supporting x86 PAEs and has more than 4 GB of physical memory. However, non-PAE x86 kernels are not supported anymore in Windows 10.
pciexpress	Default, ForceDisable	PCI_EXPRESS_POLICY	Can be used to disable support for PCI Express buses and devices.
perfmem	Size in MB	PERFORMANCE_DATA_MEMORY	Size of the buffer to allocate for performance data logging. This option acts similarly to the <i>removememory</i> element, since it prevents Windows from seeing the size specified as available memory.
quietboot	Boolean	DISABLE_BOOT_DISPLAY	Instructs Windows not to initialize the VGA video driver responsible for presenting bit-mapped graphics during the boot process. The driver is used to display boot progress information, so disabling it disables the ability of Windows to show this information.
ramdiskimagelength	Length in bytes	RAMDISK_IMAGE_LENGTH	Size of the ramdisk specified.
ramdiskimageoffset	Offset in bytes	RAMDISK_IMAGE_OFFSET	If the ramdisk contains other data (such as a header) before the virtual file system, instructs the boot loader where to start reading the ramdisk file from.
ramdisksdipath	Image file name	RAMDISK_SDI_PATH	Specifies the name of the SDI ramdisk to load.
ramdisktftpblocksize	Block size	RAMDISK_TFTP_BLOCK_SIZE	If loading a WIM ramdisk from a network Trivial FTP (TFTP) server, specifies the block size to use.
ramdisktftpclientport	Port number	RAMDISK_TFTP_CLIENT_PORT	If loading a WIM ramdisk from a network TFTP server, specifies the port.
ramdisktftpwindowsize	Window size	RAMDISK_TFTP_WINDOW_SIZE	If loading a WIM ramdisk from a network TFTP server, specifies the window size to use.
removememory	Size in bytes	REMOVE_MEMORY	Specifies an amount of memory Windows won't use.
restrictapiccluster	Cluster number	RESTRICT_APIC_CLUSTER	Defines the largest APIC cluster number to be used by the system.
resumeobject	Object GUID	ASSOCIATED_RESUME_OBJECT	Describes which application to use for resuming from hibernation, typically Winresume.exe.
safeboot	Minimal, Network, DsRepair	SAFEBOOT	Specifies options for a safe-mode boot. Minimal corresponds to safe mode without networking, Network to safe mode with networking, and DsRepair to safe mode with Directory Services Restore mode. (See the "Safe mode" section later in this chapter.)

BCD Element	Values	BCD Element Code ³	Meaning
safebootalternateshell	Boolean	SAFEBOOT_ALTERNATE_SHELL	Tells Windows to use the program specified by the HKLM\SYSTEM\CurrentControlSet\Control\SafeBoot\AlternateShell value as the graphical shell rather than the default, which is Windows Explorer. This option is referred to as safe mode with command prompt in the alternate boot menu.
sos	Boolean	SOS	Causes Windows to list the device drivers marked to load at boot time and then to display the system version number (including the build number), amount of physical memory, and number of processors.
systemroot	String	SYSTEM_ROOT	Specifies the path, relative to osdevice, in which the operating system is installed.
targetname	Name	KERNEL_DEBUGGER_USB_TARGETNAME	For USB debugging, assigns a name to the machine that is being debugged.
tpmbootentropy	Default, ForceDisable, ForceEnable	TPM_BOOT_ENTROPY_POLICY	Forces a specific TPM Boot Entropy policy to be selected by the boot loader and passed on to the kernel. TPM Boot Entropy, when used, seeds the kernel's random number generator (RNG) with data obtained from the TPM (if present).
usefirmwarepcisettings	Boolean	USE_FIRMWARE_PCI_SETTINGS	Stops Windows from dynamically assigning IO/IRQ resources to PCI devices and leaves the devices configured by the BIOS. See Microsoft Knowledge Base article 148501 for more information.
uselegacyapicmode	Boolean	USE_LEGACY_APIC_MODE	Forces usage of basic APIC functionality even though the chipset reports extended APIC functionality as present. Used in cases of hardware errata and/or incompatibility.
usephysicaldestination	Boolean	USE_PHYSICAL_DESTINATION,	Forces the use of the APIC in physical destination mode.
useplatformclock	Boolean	USE_PLATFORM_CLOCK	Forces usage of the platform's clock source as the system's performance counter.
vga	Boolean	USE_VGA_DRIVER	Forces Windows to use the VGA display driver instead of the third-party high-performance driver.
winpe	Boolean	WINPE	Used by Windows PE, this option causes the configuration manager to load the registry SYSTEM hive as a volatile hive such that changes made to it in memory are not saved back to the hive image.
x2apicpolicy	Disabled, Enabled, Default	X2APIC_POLICY	Specifies whether extended APIC functionality should be used if the chipset supports it. Disabled is equivalent to setting uselegacyapicmode, whereas Enabled forces ACPI functionality on even if errata are detected. Default uses the chipset's reported capabilities (unless errata are present).
xsavepolicy	Integer	XSAVEPOLICY	Forces the given XSAVE policy to be loaded from the XSAVE Policy Resource Driver (Hwpolicy.sys).

BCD Element	Values	BCD Element Code ³	Meaning
xsaveaddfeature0-7	Integer	XSAVEADDFEATURE0-7	Used while testing support for XSAVE on modern Intel processors; allows for faking that certain processor features are present when, in fact, they are not. This helps increase the size of the CONTEXT structure and confirms that applications work correctly with extended features that might appear in the future. No actual extra functionality will be present, however.
xsaveremovefeature	Integer	XSAVEREMOVEFEATURE	Forces the entered XSAVE feature not to be reported to the kernel, even though the processor supports it.
xsaveprocessorsmask	Integer	XSAVEPROCESSORSMASK	Bitmask of which processors the XSAVE policy should apply to.
xsavedisable	Boolean	XSAVEDISABLE	Turns off support for the XSAVE functionality even though the processor supports it.

³ All the BCD elements codes for the Windows OS Loader start with BCDE_OSLOADER_TYPE, but this has been omitted due to limited space.

TABLE 12-5 BCD options for the Windows Hypervisor loader (hvloader)

BCD Element	Values	BCD Element Code ⁴	Meaning
hypervisorlaunchtype	Off Auto	HYPervisor_LAUNCH_TYPE	Enables loading of the hypervisor on a Hyper-V system or forces it to be disabled.
hypervisordebug	Boolean	HYPervisor_DEBUGGER_ENABLED	Enables or disables the Hypervisor Debugger.
hypervisordebugtype	Serial 1394 None Net	HYPervisor_DEBUGGER_TYPE	Specifies the Hypervisor Debugger type (through a serial port or through an IEEE-1394 or network interface).
hypervisoriommpolicy	Default Enable Disable	HYPervisor_IOMMU_POLICY	Enables or disables the hypervisor DMA Guard, a feature that blocks direct memory access (DMA) for all hot-pluggable PCI ports until a user logs in to Windows.
hypervisormsrfilterpolicy	Disable Enable	HYPervisor_MSR_FILTER_POLICY	Controls whether the root partition is allowed to access restricted MSRs (model specific registers).
hypervisormmionxpolicy	Disable Enable	HYPervisor_MMIO_NX_POLICY	Enables or disables the No-Execute (NX) protection for UEFI runtime service code and data memory regions.
hypervisorenforced-codeintegrity	Disable Enable Strict	HYPervisor_ENFORCED_CODE_INTEGRITY	Enables or disables the Hypervisor Enforced Code Integrity (HVCI), a feature that prevents the root partition kernel from allocating unsigned executable memory pages.
hypervisorschedulertype	Classic Core Root	HYPervisor_SCHEDULER_TYPE	Specifies the hypervisor's partitions scheduler type.
hypervisordisableslat	Boolean	HYPervisor_SLAT_DISABLED	Forces the hypervisor to ignore the presence of the second layer address translation (SLAT) feature if supported by the processor.
hypervisornumproc	Integer	HYPervisor_NUM_PROC	Specifies the maximum number of logical processors available to the hypervisor.

BCD Element	Values	BCD Element Code ⁴	Meaning
hypervisorrootprocperr-node	Integer	HYPervisor_ROOT_PROC_PER_NODE	Specifies the total number of root virtual processors per node.
hypervisorrootproc	Integer	HYPervisor_ROOT_PROC	Specifies the maximum number of virtual processors in the root partition.
hypervisorbaudrate	Baud rate in bps	HYPervisor_DEBUGGER_BAUDRATE	If using serial hypervisor debugging, specifies the baud rate to use.
hypervisorchannel	Channel number from 0 to 62	HYPervisor_DEBUGGER_1394_CHANNEL	If using FireWire (IEEE 1394) hypervisor debugging, specifies the channel number to use.
hypervisordebugport	COM port number	HYPervisor_DEBUGGER_PORT_NUMBER	If using serial hypervisor debugging, specifies the COM port to use.
hypervisoruselargevtlb	Boolean	HYPervisor_USE_LARGE_VTLB	Enables the hypervisor to use a larger number of virtual TLB entries.
hypervisorhostip	IP address (binary format)	HYPervisor_DEBUGGER_NET_HOST_IP	Specifies the IP address of the target machine (the debugger) used in hypervisor network debugging.
hypervisorhostport	Integer	HYPervisor_DEBUGGER_NET_HOST_PORT	Specifies the network port used in hypervisor network debugging.
hypervisorusekey	String	HYPervisor_DEBUGGER_NET_KEY	Specifies the encryption key used for encrypting the debug packets sent through the wire.
hypervisorbusparams	String	HYPervisor_DEBUGGER_BUSPARAMS	Specifies the bus, device, and function numbers of the network adapter used for hypervisor debugging.
hypervisordhcp	Boolean	HYPervisor_DEBUGGER_NET_DHCP	Specifies whether the Hypervisor Debugger should use DHCP for getting the network interface IP address.

⁴ All the BCD elements codes for the Windows Hypervisor Loader start with BCDE_OSLOADER_TYPE, but this has been omitted due to limited space.

All the entries in the BCD store play a key role in the startup sequence. Inside each boot entry (a boot entry is a BCD object), there are listed all the boot options, which are stored into the hive as registry subkeys (as shown in Figure 12-5). These options are called BCD elements. The Windows Boot Manager is able to add or remove any boot option, either in the physical hive or only in memory. This is important because, as we describe later in the section “The boot menu,” not all the BCD options need to reside in the physical hive.

If the Boot Configuration Data hive is corrupt, or if some error has occurred while parsing its boot entries, the Boot Manager retries the operation using the Recovery BCD hive. The Recovery BCD hive is normally stored in \EFI\Microsoft\Recovery\BCD. The system could be configured for direct use of this store, skipping the normal one, via the *recoverybcd* parameter (stored in the UEFI boot variable) or via the *Bootstat.log* file.

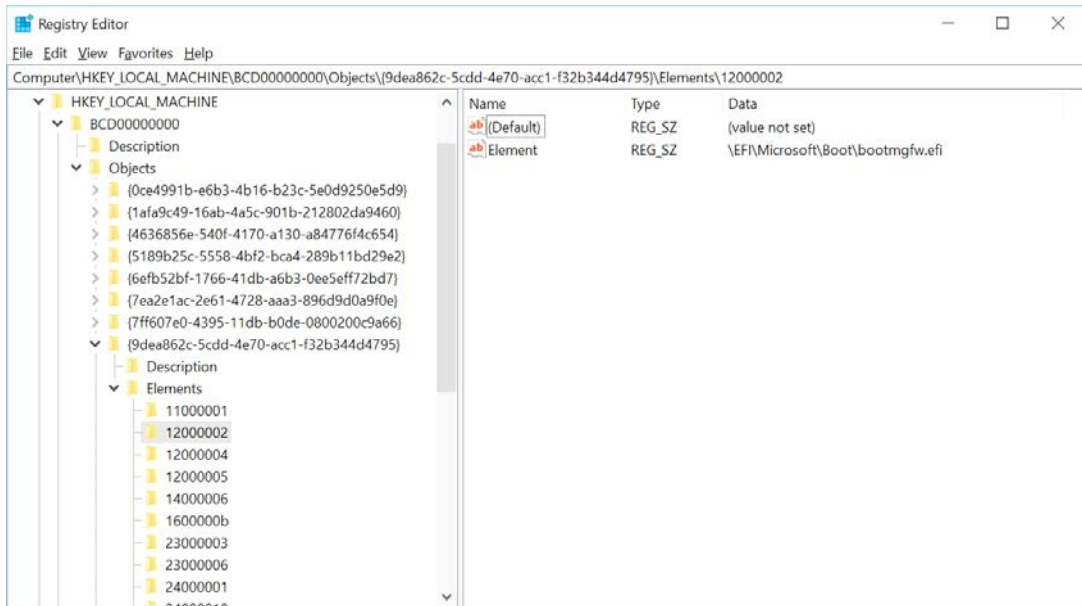

FIGURE 12-5 An example screenshot of the Windows Boot Manager’s BCD objects and their associated boot options (BCD elements).

The system is ready to load the Secure Boot policies, show the boot menu (if needed), and launch the boot application. The list of boot certificates that the firmware can or cannot trust is located in the *db* and *dbx* UEFI authenticated variables. The code integrity boot library reads and parses the UEFI variables, but these control only whether a particular boot manager module can be loaded. Once the Windows Boot Manager is launched, it enables you to further customize or extend the UEFI-supplied Secure Boot configuration with a Microsoft-provided certificates list. The Secure Boot policy file (stored in `\EFI\Microsoft\Boot\SecureBootPolicy.p7b`), the platform manifest policies files (.pm files), and the supplemental policies (.pol files) are parsed and merged with the policies stored in the UEFI variables. Because the kernel code integrity engine ultimately takes over, the additional policies contain OS-specific information and certificates. In this way, a secure edition of Windows (like the S version) could verify multiple certificates without consuming precious UEFI resources. This creates the root of trust because the files that specify new customized certificates lists are signed by a digital certificate contained in the UEFI allowed signatures database.

If not disabled by boot options (*nointegritycheck* or *testsigning*) or by a Secure Boot policy, the Boot Manager performs a self-verification of its own integrity: it opens its own file from the hard disk and validates its digital signature. If Secure Boot is on, the signing chain is validated against the Secure Boot signing policies.

The Boot Manager initializes the Boot Debugger and checks whether it needs to display an OEM bitmap (through the BGRT system ACPI table). If so, it clears the screen and shows the logo. If Windows has enabled the BCD setting to inform Bootmgr of a hibernation resume (or of a hybrid boot), this shortcuts the boot process by launching the Windows Resume Application, *Winresume.efi*, which will read the contents of the hibernation file into memory and transfer control to code in the kernel that

resumes a hibernated system. That code is responsible for restarting drivers that were active when the system was shut down. `Hiberfil.sys` is valid only if the last computer shutdown was a hibernation or a hybrid boot. This is because the hibernation file is invalidated after a resume to avoid multiple resumes from the same point. The Windows Resume Application BCD object is linked to the Boot Manager descriptor through a specific BCD element (called *resumeobject*, which is described in the “Hibernation and Fast Startup” section later in this chapter).

Bootmgr detects whether OEM custom boot actions are registered through the relative BCD element, and, if so, processes them. At the time of this writing, the only custom boot action supported is the launch of an OEM boot sequence. In this way the OEM vendors can register a customized recovery sequence invoked through a particular key pressed by the user at startup.

The boot menu

In Windows 8 and later, in the standard boot configurations, the classical (legacy) boot menu is never shown because a new technology, modern boot, has been introduced. Modern boot provides Windows with a rich graphical boot experience while maintaining the ability to dive more deeply into boot-related settings. In this configuration, the final user is able to select the OS that they want to execute, even with touch-enabled systems that don’t have a proper keyboard and mouse. The new boot menu is drawn on top of the Win32 subsystem; we describe its architecture later in this chapter in the “Smss, Csrss, and Wininit” section.

The *bootmenupolicy* boot option controls whether the Boot Loader should use the old or new technology to show the boot menu. If there are no OEM boot sequences, Bootmgr enumerates the system boot entry GUIDs that are linked into the *displayorder* boot option of the Boot Manager. (If this value is empty, Bootmgr relies on the default entry.) For each GUID found, Bootmgr opens the relative BCD object and queries the type of boot application, its startup device, and the readable description. All three attributes must exist; otherwise, the Boot entry is considered invalid and will be skipped. If Bootmgr doesn’t find a valid boot application, it shows an error message to the user and the entire Boot process is aborted. The boot menu display algorithm begins here. One of the key functions, *BmpProcessBootEntry*, is used to decide whether to show the Legacy Boot menu:

- If the boot menu policy of the default boot application (and not of the Bootmgr entry) is explicitly set to the Modern type, the algorithm exits immediately and launches the default entry through the *BmpLaunchBootEntry* function. Noteworthy is that in this case no user keys are checked, so it is not possible to force the boot process to stop. If the system has multiple boot entries, a special BCD option⁵ is added to the in-memory boot option list of the default boot application. In this way, in the later stages of the System Startup, Winlogon can recognize the option and show the Modern menu.
- Otherwise, if the boot policy for the default boot application is legacy (or is not set at all) and there is only an entry, *BmpProcessBootEntry* checks whether the user has pressed the F8 or F10 key. These are described in the `bootmgr.xml` resource file as the Advanced Options and Boot

⁵ The multi-boot “special option” has no name. Its element code is `BCDE_LIBRARY_TYPE_MULTI_BOOT_SYSTEM` (that corresponds to 0x16000071 in hexadecimal value).

Options keys. If *Bootmgr* detects that one of the keys is pressed at startup time, it adds the relative BCD element to the in-memory boot options list of the default boot application (the BCD element is not written to the disk). The two boot options are processed later in the Windows Loader. Finally, *BmpProcessBootEntry* checks whether the system is forced to display the boot menu even in case of only one entry (through the relative “displaybootmenu” BCD option).

- In case of multiple boot entries, the timeout value (stored as a BCD option) is checked and, if it is set to 0, the default application is immediately launched; otherwise, the Legacy Boot menu is shown with the *BmDisplayBootMenu* function.

While displaying the Legacy Boot menu, *Bootmgr* enumerates the installed boot tools that are listed in the *toolsdisplayorder* boot option of the Boot Manager.

Launching a boot application

The last goal of the Windows Boot Manager is to correctly launch a boot application, even if it resides on a BitLocker-encrypted drive, and manage the recovery sequence in case something goes wrong. *BmpLaunchBootEntry* receives a GUID and the boot options list of the application that needs to be executed. One of the first things that the function does is check whether the specified entry is a Windows Recovery (WinRE) entry (through a BCD element). These kinds of boot applications are used when dealing with the recovery sequence. If the entry is a WinRE type, the system needs to determine the boot application that WinRE is trying to recover. In this case, the startup device of the boot application that needs to be recovered is identified and then later unlocked (in case it is encrypted).

The *BmTransferExecution* routine uses the services provided by the boot library to open the device of the boot application, identify whether the device is encrypted, and, if so, decrypt it and read the target OS loader file. If the target device is encrypted, the Windows Boot Manager tries first to get the master key from the TPM. In this case, the TPM unseals the master key only if certain conditions are satisfied (see the next paragraph for more details). In this way, if some startup configuration has changed (like the enablement of Secure Boot, for example), the TPM won't be able to release the key. If the key extraction from the TPM has failed, the Windows Boot Manager displays a screen similar to the one shown in Figure 12-6, asking the user to enter an unlock key (even if the boot menu policy is set to Modern, because at this stage the system has no way to launch the Modern Boot user interface). At the time of this writing, *Bootmgr* supports four different unlock methods: PIN, passphrase, external media, and recovery key. If the user is unable to provide a key, the startup process is interrupted and the Windows recovery sequence starts.

The firmware is used to read and verify the target OS loader. The verification is done through the Code Integrity library, which applies the secure boot policies (both the systems and all the customized ones) on the file's digital signature. Before actually passing the execution to the target boot application, the Windows Boot Manager needs to notify the registered components (ETW and Measured Boot in particular) that the boot application is starting. Furthermore, it needs to make sure that the TPM can't be used to unseal anything else.

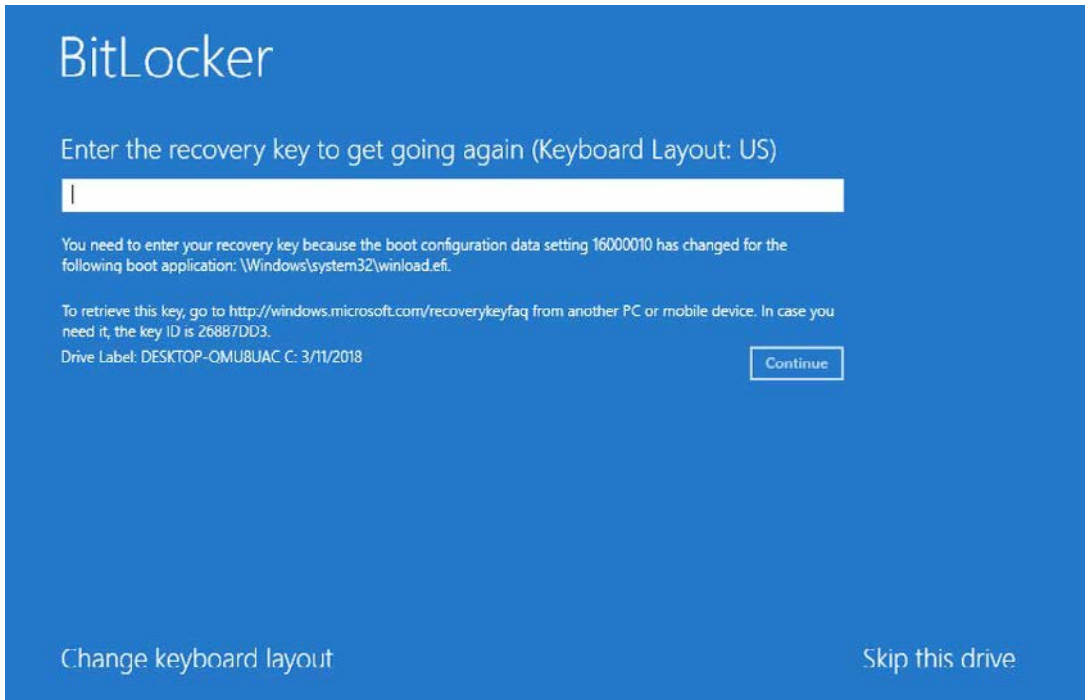

FIGURE 12-6 The BitLocker recovery procedure, which has been raised because something in the boot configuration has changed.

Finally, the code execution is transferred to the Windows Loader through *BllmgStartBootApplication*. This routine returns only in case of certain errors. As before, the Boot Manager manages the latter situation by launching the Windows Recovery Sequence.

Measured Boot

In late 2006, Intel introduced the Trusted Execution Technology (TXT), which ensures that an authentic operating system is started in a trusted environment and not modified or altered by an external agent (like malware). The TXT uses a TPM and cryptographic techniques to provide measurements of software and platform (UEFI) components. Windows 8.1 and later support a new feature called Measured Boot, which measures each component, from firmware up through the boot start drivers, stores those measurements in the TPM of the machine, and then makes available a log that can be tested remotely to verify the boot state of the client. This technology would not exist without the TPM. The term *measurement* refers to a process of calculating a cryptographic hash of a particular entity, like code, data structures, configuration, or anything that can be loaded in memory. The measurements are used for various purposes. Measured Boot provides antimalware software with a trusted (resistant to spoofing and tampering) log of all boot components that started before Windows. The antimalware software uses the log to determine whether components that ran before it are trustworthy or are infected with malware. The software on the local machine sends the log to a remote server for evaluation. Working with the TPM and non-Microsoft software, Measured Boot allows a trusted server on the network to verify the integrity of the Windows startup process.

The main rules of the TPM are the following:

- Provide a secure nonvolatile storage for protecting secrets
- Provide platform configuration registers (PCRs) for storing measurements
- Provide hardware cryptographic engines and a true random number generator

The TPM stores the Measured Boot measurements in PCRs. Each PCR provides a storage area that allows an unlimited number of measurements in a fixed amount of space. This feature is provided by a property of cryptographic hashes. The Windows Boot Manager (or the Windows Loader in later stages) never writes directly into a PCR register; it “extends” the PCR content. The “extend” operation takes the current value of the PCR, appends the new measured value, and calculates a cryptographic hash (SHA-1 or SHA-256 usually) of the combined value. The hash result is the new PCR value. The “extend” method assures the order-dependency of the measurements. One of the properties of the cryptographic hashes is that they are order-dependent. This means that hashing two values A and B produces two different results from hashing B and A. Because PCRs are extended (not written), even if malicious software is able to extend a PCR, the only effect is that the PCR would carry an invalid measurement. Another property of the cryptographic hashes is that it’s impossible to create a block of data that produces a given hash. Thus, it’s impossible to extend a PCR to get a given result, except by measuring the same objects in exactly the same order.

At the early stages of the boot process, the System Integrity module of the boot library registers different callback functions. Each callback will be called later at different points in the startup sequence with the goal of managing measured-boot events, like Test Signing enabling, Boot Debugger enabling, PE Image loading, boot application starting, hashing, launching, exiting, and BitLocker unlocking. Each callback decides which kind of data to hash and to extend into the TPM PCR registers. For instance, every time the Boot Manager or the Windows Loader starts an external executable image, it generates three measured boot events that correspond to different phases of the Image loading: *LoadStarting*, *ApplicationHashed*, and *ApplicationLaunched*. In this case, the measured entities, which are sent to the PCR registers (11 and 12) of the TPM, are the following: hash of the image, hash of the digital signature of the image, image base, and size.

All the measurements will be employed later in Windows when the system is completely started, for a procedure called *attestation*. Because of the uniqueness property of cryptographic hashes, you can use PCR values and their logs to identify exactly what version of software is executing, as well as its environment. At this stage, Windows uses the TPM to provide a TPM quote, where the TPM signs the PCR values to assure that values are not maliciously or inadvertently modified in transit. This guarantees the authenticity of the measurements. The quoted measurements are sent to an attestation authority, which is a trusted third-party entity that is able to authenticate the PCR values and translate those values by comparing them with a database of known good values. Describing all the models used for attestation is outside the scope of this book. The final goal is that the remote server confirms whether the client is a trusted entity or could be altered by some malicious component.

Earlier we explained how the Boot Manager is able to automatically unlock the BitLocker-encrypted startup volume. In this case, the system takes advantage of another important service provided by the TPM: secure nonvolatile storage. The TPM nonvolatile random access memory (NVRAM) is persistent

across power cycles and has more security features than system memory. While allocating TPM NVRAM, the system should specify the following:

- **Read access rights** Specify which TPM privilege level, called *locality*, can read the data. More importantly, specify whether any PCRs must contain specific values in order to read the data.
- **Write access rights** The same as above but for write access.
- **Attributes/permissions** Provide optional authorizations values for reading or writing (like a password) and temporal or persistent locks (that is, the memory can be locked for write access).

The first time the user encrypts the boot volume, BitLocker encrypts its volume master key (VMK) with another random symmetric key and then “seals” that key using the extended TPM PCR values (in particular, PCR 7 and 11, which measure the BIOS and the Windows Boot sequence) as the sealing condition. *Sealing* is the act of having the TPM encrypt a block of data so that it can be decrypted only by the same TPM that has encrypted it, only if the specified PCRs have the correct values. In subsequent boots, if the “unsealing” is requested by a compromised boot sequence or by a different BIOS configuration, TPM refuses the request to unseal and reveal the VMK encryption key.

EXPERIMENT: Invalidate TPM measurements

In this experiment, you explore a quick way to invalidate the TPM measurements by invalidating the BIOS configuration. Before measuring the startup sequence, drivers, and data, Measured Boot starts with a static measurement of the BIOS configuration (stored in PCR1). The measured BIOS configuration data strictly depends on the hardware manufacturer and sometimes even includes the UEFI boot order list. Before starting the experiment, verify that your system includes a valid TPM. Type **tpm.msc** in the Start menu search box and execute the snap-in. The Trusted Platform Module (TPM) Management console should appear. Verify that a TPM is present and enabled in your system by checking that the Status box is set to The TPM Is Ready For Use.

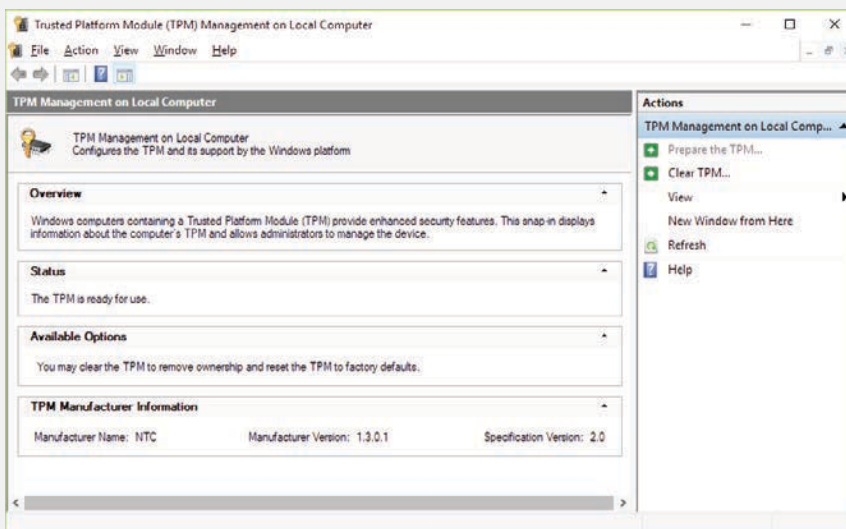

Start the BitLocker encryption of the system volume. If your system volume is already encrypted, you can skip this step. You must be sure to save the recovery key, though. (You can check the recovery key by selecting **Back Up Your Recovery Key**, which is located in the BitLocker drive encryption applet of the Control Panel.) Open File Explorer by clicking its taskbar icon, and navigate to This PC. Right-click the system volume (the volume that contains all the Windows files, usually C:) and select **Turn On BitLocker**. After the initial verifications are made, select **Let BitLocker Automatically Unlock My Drive** when prompted on the Choose How to Unlock Your Drive at Startup page. In this way, the VMK will be sealed by the TPM using the boot measurements as the “unsealing” key. Be careful to save or print the recovery key; you’ll need it in the next stage. Otherwise, you won’t be able to access your files anymore. Leave the default value for all the other options.

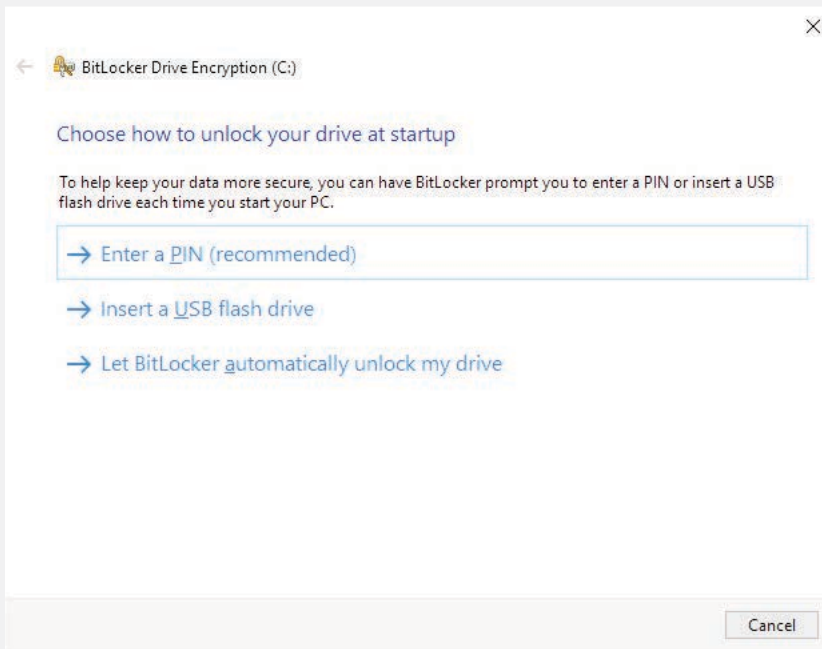

After the encryption is complete, switch off your computer and start it by entering the UEFI BIOS configuration. (This procedure is different for each PC manufacturer; check the hardware user manual for directions for entering the UEFI BIOS settings.) In the BIOS configuration pages, simply change the boot order and then restart your computer. (You can change the startup boot order by using the UefiTool utility, which is in the downloadable files of the book.) If your hardware manufacturer includes the boot order in the TPM measurements, you should get the BitLocker recovery message before Windows boots. Otherwise, to invalidate the TPM measurements, simply insert the Windows Setup DVD or flash drive before switching on the workstation. If the boot order is correctly configured, the Windows Setup bootstrap code starts, which prints

the Press Any Key For Boot From CD Or DVD message. If you don't press any key, the system proceeds to boot the next Boot entry. In this case, the startup sequence has changed, and the TPM measurements are different. As a result, the TPM won't be able to unseal the VMK.



You can invalidate the TPM measurements (and produce the same effects) if you have Secure Boot enabled and you try to disable it. This experiment demonstrates that Measured Boot is tied to the BIOS configuration.

Trusted execution

Although Measured Boot provides a way for a remote entity to confirm the integrity of the boot process, it does not resolve an important issue: Boot Manager still trusts the machine's firmware code and uses its services to effectively communicate with the TPM and start the entire platform. At the time of this writing, attacks against the UEFI core firmware have been demonstrated multiple times. The Trusted Execution Technology (TXT) has been improved to support another important feature, called Secure Launch. Secure Launch (also known as Trusted Boot in the Intel nomenclature) provides secure authenticated code modules (ACM), which are signed by the CPU manufacturer and executed

by the chipset (and not by the firmware). Secure Launch provides the support of dynamic measurements made to PCRs that can be reset without resetting the platform. In this scenario, the OS provides a special Trusted Boot (TBOOT) module used to initialize the platform for secure mode operation and initiate the Secure Launch process.

An *authenticated code module* (ACM) is a piece of code provided by the chipset manufacturer. The ACM is signed by the manufacturer, and its code runs in one of the highest privilege levels within a special secure memory that is internal to the processor. ACMs are invoked using a special *GETSEC* instruction. There are two types of ACMs: BIOS and SINIT. While BIOS ACM measures the BIOS and performs some BIOS security functions, the SINIT ACM is used to perform the measurement and launch of the Operating System TCB (TBOOT) module. Both BIOS and SINIT ACM are usually contained inside the System BIOS image (this is not a strict requirement), but they can be updated and replaced by the OS if needed (refer to the “Secure Launch” section later in this chapter for more details).

The ACM is the core root of trusted measurements. As such, it operates at the highest security level and must be protected against all types of attacks. The processor microcode copies the ACM module in the secure memory and performs different checks before allowing the execution. The processor verifies that the ACM has been designed to work with the target chipset. Furthermore, it verifies the ACM integrity, version, and digital signature, which is matched against the public key hardcoded in the chipset fuses. The *GETSEC* instruction doesn’t execute the ACM if one of the previous checks fails.

Another key feature of Secure Launch is the support of Dynamic Root of Trust Measurement (DRTM) by the TPM. As introduced in the previous section, “Measured Boot,” 16 different TPM PCR registers (0 through 15) provide storage for boot measurements. The Boot Manager could extend these PCRs, but it’s not possible to clear their contents until the next platform reset (or power up). This explains why these kinds of measurements are called static measurements. Dynamic measurements are measurements made to PCRs that can be reset without resetting the platform. There are six dynamic PCRs (actually there are eight, but two are reserved and not usable by the OS) used by Secure Launch and the trusted operating system.

In a typical TXT Boot sequence, the boot processor, after having validated the ACM integrity, executes the ACM startup code, which measures critical BIOS components, exits ACM secure mode, and jumps to the UEFI BIOS startup code. The BIOS then measures all of its remaining code, configures the platform, and verifies the measurements, executing the *GETSEC* instruction. This TXT instruction loads the BIOS ACM module, which performs the security checks and locks the BIOS configuration. At this stage the UEFI BIOS could measure each option ROM code (for each device) and the Initial Program Load (IPL). The platform has been brought to a state where it’s ready to boot the operating system (specifically through the IPL code).

The TXT Boot sequence is part of the Static Root of Trust Measurement (SRTM) because the trusted BIOS code (and the Boot Manager) has been already verified, and it’s in a good known state that will never change until the next platform reset. Typically, for a TXT-enabled OS, a special TCB (TBOOT) module is used instead of the first kernel module being loaded. The purpose of the TBOOT module is to initialize the platform for secure mode operation and initiate the Secure Launch. The Windows TBOOT

module is named TcbLaunch.exe. Before starting the Secure Launch, the TBOOT module must be verified by the SINIT ACM module. So, there should be some components that execute the *GETSEC* instructions and start the DRTM. In the Windows Secure Launch model, this component is the boot library.

Before the system can enter the secure mode, it must put the platform in a known state. (In this state, all the processors, except the bootstrap one, are in a special idle state, so no other code could ever be executed.) The boot library executes the *GETSEC* instruction, specifying the *SENDER* operation. This causes the processor to do the following:

1. Validate the SINIT ACM module and load it into the processor's secure memory.
2. Start the DRTM by clearing all the relative dynamic PCRs and then measuring the SINIT ACM.
3. Execute the SINIT ACM code, which measures the trusted OS code and executes the Launch Control Policy. The policy determines whether the current measurements (which reside in some dynamic PCR registers) allow the OS to be considered "trusted."

When one of these checks fails, the machine is considered to be under attack, and the ACM issues a TXT reset, which prevents any kind of software from being executed until the platform has been hard reset. Otherwise, the ACM enables the Secure Launch by exiting the ACM mode and jumping to the trusted OS entry point (which, in Windows is the *TcbMain* function of the TcbLaunch.exe module). The trusted OS then takes control. It can extend and reset the dynamic PCRs for every measurement that it needs (or by using another mechanism that assures the chain of trust).

Describing the entire Secure Launch architecture is outside the scope of this book. Please refer to the Intel manuals for the TXT specifications. Refer to the "Secure Launch" section, later in this chapter, for a description of how Trusted Execution is implemented in Windows. Figure 12-7 shows all the components involved in the Intel TXT technology.

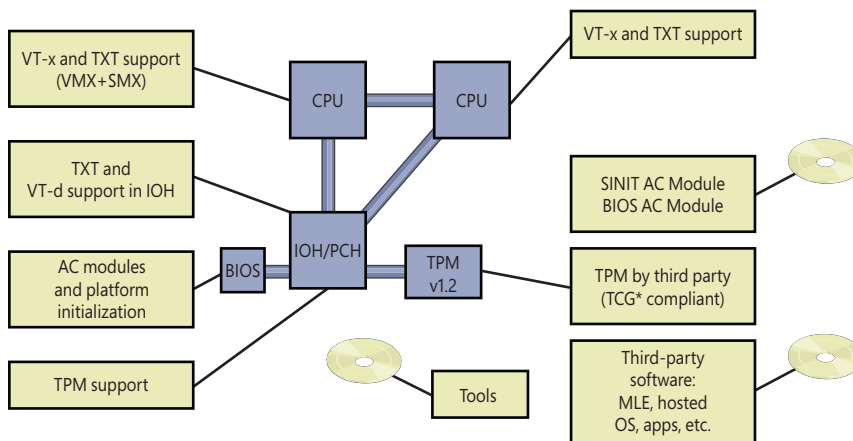

FIGURE 12-7 Intel TXT (Trusted Execution Technology) components.

The Windows OS Loader

The Windows OS Loader (Winload) is the boot application launched by the Boot Manager with the goal of loading and correctly executing the Windows kernel. This process includes multiple primary tasks:

- Create the execution environment of the kernel. This involves initializing, and using, the kernel's page tables and developing a memory map. The EFI OS Loader also sets up and initializes the kernel's stacks, shared user page, GDT, IDT, TSS, and segment selectors.
- Load into memory all modules that need to be executed or accessed before the disk stack is initialized. These include the kernel and the HAL because they handle the early initialization of basic services once control is handed off from the OS Loader. Boot-critical drivers and the registry system hive are also loaded into memory.
- Determine whether Hyper-V and the Secure Kernel (VSM) should be executed, and, if so, correctly load and start them.
- Draw the first background animation using the new high-resolution boot graphics library (BGFX, which replaces the old Bootvid.dll driver).
- Orchestrate the Secure Launch boot sequence in systems that support Intel TXT. (For a complete description of Measured Boot, Secure Launch, and Intel TXT, see the respective sections earlier in this chapter). This task was originally implemented in the hypervisor loader, but it has moved starting from Windows 10 October Update (RS5).

The Windows loader has been improved and modified multiple times during each Windows release. *OslMain* is the main loader function (called by the Boot Manager) that (re)initializes the boot library and calls the internal *OslpMain*. The boot library, at the time of this writing, supports two different execution contexts:

- Firmware context means that the paging is disabled. Actually, it's not disabled but it's provided by the firmware that performs the one-to-one mapping of physical addresses, and only firmware services are used for memory management. Windows uses this execution context in the Boot Manager.
- Application context means that the paging is enabled and provided by the OS. This is the context used by the Windows Loader.

The Boot Manager, just before transferring the execution to the OS loader, creates and initializes the four-level x64 page table hierarchy that will be used by the Windows kernel, creating only the self-map and the identity mapping entries. *OslMain* switches to the Application execution context, just before starting. The *OslPrepareTarget* routine captures the boot/shutdown status of the last boot, reading from the bootstat.dat file located in the system root directory.

When the last boot has failed more than twice, it returns to the Boot Manager for starting the Recovery environment. Otherwise, it reads in the SYSTEM registry hive, \Windows\System32\Config\System, so that it can determine which device drivers need to be loaded to accomplish the boot. (A hive is a file that contains a registry subtree. More details about the registry were provided in Chapter 10.) Then it initializes the BGFX display library (drawing the first background image) and shows the Advanced Options menu if needed (refer to the section "The boot menu" earlier in this chapter). One

of the most important data structures needed for the NT kernel boot, the Loader Block, is allocated and filled with basic information, like the system hive base address and size, a random entropy value (queried from the TPM if possible), and so on.

OsInitializeLoaderBlock contains code that queries the system's ACPI BIOS to retrieve basic device and configuration information (including event time and date information stored in the system's CMOS). This information is gathered into internal data structures that will be stored under the HKLM\HARDWARE\DESCRIPTION registry key later in the boot. This is mostly a legacy key that exists only for compatibility reasons. Today, it's the Plug and Play manager database that stores the true information on hardware.

Next, Winload begins loading the files from the boot volume needed to start the kernel initialization. The boot volume is the volume that corresponds to the partition on which the system directory (usually \Windows) of the installation being booted is located. Winload follows these steps:

1. Determines whether the hypervisor or the Secure Kernel needs to be loaded (through the *hypervisorlaunchtype* BCD option and the VSM policy); if so, it starts phase 0 of the hypervisor setup. Phase 0 pre-loads the HV loader module (Hvloader.dll) into RAM memory and executes its *HvLoadHypervisor* initialization routine. The latter loads and maps the hypervisor image (Hvix64.exe, Hvax64.exe, or Hvaa64.exe, depending on the architecture) and all its dependencies in memory.
2. Enumerates all the firmware-enumerable disks and attaches the list in the Loader Parameter Block. Furthermore, loads the Synthetic Initial Machine Configuration hive (Imc.hiv) if specified by the configuration data and attaches it to the loader block.
3. Initializes the kernel Code Integrity module (Ci.dll) and builds the CI Loader block. The Code Integrity module will be then shared between the NT kernel and Secure Kernel.
4. Processes any pending firmware updates. (Windows 10 supports firmware updates distributed through Windows Update.)
5. Loads the appropriate kernel and HAL images (Ntoskrnl.exe and Hal.dll by default). If Winload fails to load either of these files, it prints an error message. Before properly loading the two modules' dependencies, Winload validates their contents against their digital certificates and loads the API Set Schema system file. In this way, it can process the API Set imports.
6. Initializes the debugger, loading the correct debugger transport.
7. Loads the CPU microcode update module (Mcupdate.dll), if applicable.
8. *OsLoadAllModules* finally loads the modules on which the NT kernel and HAL depend, ELAM drivers, core extensions, TPM drivers, and all the remaining boot drivers (respecting the load order—the file system drivers are loaded first). Boot device drivers are drivers necessary to boot the system. The configuration of these drivers is stored in the SYSTEM registry hive. Every device driver has a registry subkey under HKLM\SYSTEM\CurrentControlSet\Services. For example, Services has a subkey named rdyboost for the ReadyBoost driver, which you can see in Figure 12-8 (for a detailed description of the Services registry entries, see the section “Services” in Chapter 10). All the boot drivers have a start value of *SERVICE_BOOT_START* (0).

9. At this stage, to properly allocate physical memory, Winload is still using services provided by the EFI Firmware (the *AllocatePages* boot service routine). The virtual address translation is instead managed by the boot library, running in the Application execution context.

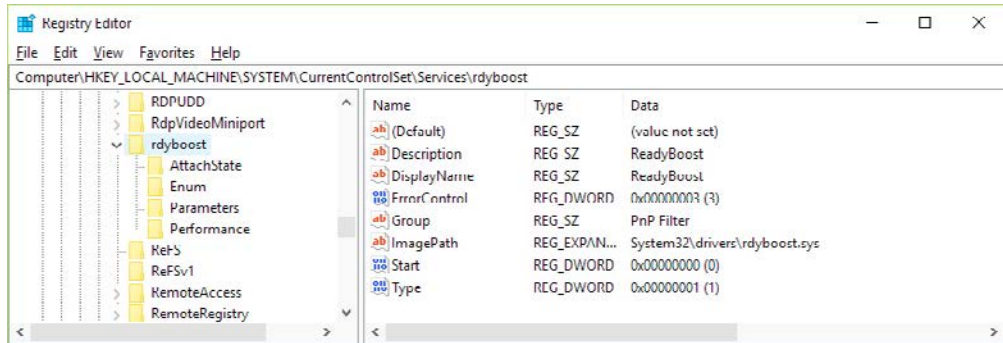

FIGURE 12-8 ReadyBoost driver service settings.

10. Reads in the NLS (National Language System) files used for internationalization. By default, these are *l_intl.nls*, *C_1252.nls*, and *C_437.nls*.
11. If the evaluated policies require the startup of the VSM, executes phase 0 of the Secure Kernel setup, which resolves the locations of the VSM Loader support routines (exported by the *Hvloader.dll* module), and loads the Secure Kernel module (*Securekernel.exe*) and all of its dependencies.
12. For the S edition of Windows, determines the minimum user-mode configurable code integrity signing level for the Windows applications.
13. Calls the *OslArchpKernelSetupPhase0* routine, which performs the memory steps required for kernel transition, like allocating a GDT, IDT, and TSS; mapping the HAL virtual address space; and allocating the kernel stacks, shared user page, and USB legacy handoff. Winload uses the UEFI *GetMemoryMap* facility to obtain a complete system physical memory map and maps each physical page that belongs to EFI Runtime Code/Data into virtual memory space. The complete physical map will be passed to the OS kernel.
14. Executes phase 1 of VSM setup, copying all the needed ACPI tables from VTL0 to VTL1 memory. (This step also builds the VTL1 page tables.)
15. The virtual memory translation module is completely functional, so Winload calls the *ExitBootServices* UEFI function to get rid of the firmware boot services and remaps all the remaining Runtime UEFI services into the created virtual address space, using the *SetVirtualAddressMap* UEFI runtime function.
16. If needed, launches the hypervisor and the Secure Kernel (exactly in this order). If successful, the execution control returns to Winload in the context of the Hyper-V Root Partition. (Refer to Chapter 9, "Virtualization technologies," for details about Hyper-V.)
17. Transfers the execution to the kernel through the *OslArchTransferToKernel* routine.

Booting from iSCSI

Internet SCSI (iSCSI) devices are a kind of network-attached storage in that remote physical disks are connected to an iSCSI Host Bus Adapter (HBA) or through Ethernet. These devices, however, are different from traditional network-attached storage (NAS) because they provide block-level access to disks, unlike the logical-based access over a network file system that NAS employs. Therefore, an iSCSI-connected disk appears as any other disk drive, both to the boot loader and to the OS, as long as the Microsoft iSCSI Initiator is used to provide access over an Ethernet connection. By using iSCSI-enabled disks instead of local storage, companies can save on space, power consumption, and cooling.

Although Windows has traditionally supported booting only from locally connected disks or network booting through PXE, modern versions of Windows are also capable of natively booting from iSCSI devices through a mechanism called iSCSI Boot. As shown in Figure 12-9, the boot loader (Winload.efi) detects whether the system supports iSCSI boot devices reading the iSCSI Boot Firmware Table (iBFT) that must be present in physical memory (typically exposed through ACPI). Thanks to the iBFT table, Winload knows the location, path, and authentication information for the remote disk. If the table is present, Winload opens and loads the network interface driver provided by the manufacturer, which is marked with the `CM_SERVICE_NETWORK_BOOT_LOAD (0x1)` boot flag.

Additionally, Windows Setup also has the capability of reading this table to determine bootable iSCSI devices and allow direct installation on such a device, such that no imaging is required. In combination with the Microsoft iSCSI Initiator, this is all that's required for Windows to boot from iSCSI.

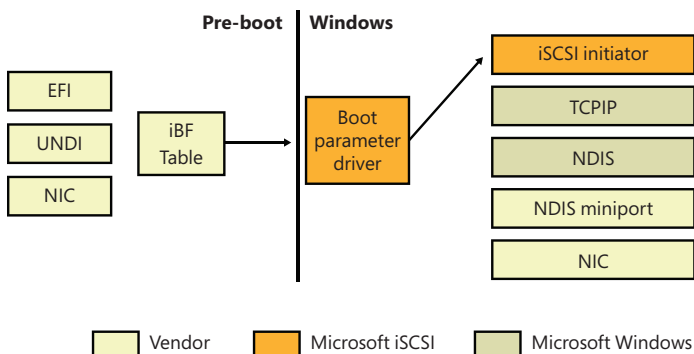

FIGURE 12-9 iSCSI boot architecture.

The hypervisor loader

The hypervisor loader is the boot module (its file name is `Hvloader.dll`) used to properly load and start the Hyper-V hypervisor and the Secure Kernel. For a complete description of Hyper-V and the Secure Kernel, refer to Chapter 9. The hypervisor loader module is deeply integrated in the Windows Loader and has two main goals:

- Detect the hardware platform; load and start the proper version of the Windows Hypervisor (`Hvix64.exe` for Intel Systems, `Hvax64.exe` for AMD systems and `Hvaa64.exe` for ARM64 systems).
- Parse the Virtual Secure Mode (VSM) policy; load and start the Secure Kernel.

In Windows 8, this module was an external executable loaded by Winload on demand. At that time the only duty of the hypervisor loader was to load and start Hyper-V. With the introduction of the VSM and Trusted Boot, the architecture has been redesigned for a better integration of each component.

As previously mentioned, the hypervisor setup has two different phases. The first phase begins in Winload, just after the initialization of the NT Loader Block. The HvLoader detects the target platform through some CPUID instructions, copies the UEFI physical memory map, and discovers the IOAPICs and IOMMUs. Then HvLoader loads the correct hypervisor image (and all the dependencies, like the Debugger transport) in memory and checks whether the hypervisor version information matches the one expected. (This explains why the HvLoader couldn't start a different version of Hyper-V.) HvLoader at this stage allocates the hypervisor loader block, an important data structure used for passing system parameters between HvLoader and the hypervisor itself (similar to the Windows loader block). The most important step of phase 1 is the construction of the hypervisor page tables hierarchy. The just-born page tables include only the mapping of the hypervisor image (and its dependencies) and the system physical pages below the first megabyte. The latter are identity-mapped and are used by the startup transitional code (this concept is explained later in this section).

The second phase is initiated in the final stages of Winload: the UEFI firmware boot services have been discarded, so the HvLoader code copies the physical address ranges of the UEFI Runtime Services into the hypervisor loader block; captures the processor state; disables the interrupts, the debugger, and paging; and calls *HvlpTransferToHypervisorViaTransitionSpace* to transfer the code execution to the below 1 MB physical page. The code located here (the transitional code) can switch the page tables, re-enable paging, and move to the hypervisor code (which actually creates the two different address spaces). After the hypervisor starts, it uses the saved processor context to properly yield back the code execution to Winload in the context of a new virtual machine, called root partition (more details available in Chapter 9).

The launch of the virtual secure mode is divided in three different phases because some steps are required to be done after the hypervisor has started.

1. The first phase is very similar to the first phase in the hypervisor setup. Data is copied from the Windows loader block to the just-allocated VSM loader block; the master key, IDK key, and Crashdump key are generated; and the SecureKernel.exe module is loaded into memory.
2. The second phase is initiated by Winload in the late stages of *OsIPrepareTarget*, where the hypervisor has been already initialized but not launched. Similar to the second phase of the hypervisor setup, the UEFI runtime services physical address ranges are copied into the VSM loader block, along with ACPI tables, code integrity data, the complete system physical memory map, and the hypercall code page. Finally, the second phase constructs the protected page tables hierarchy used for the protected VTL1 memory space (using the *OsIpVsmBuildPageTables* function) and builds the needed GDT.
3. The third phase is the final "launch" phase. The hypervisor has already been launched. The third phase performs the final checks. (Checks such as whether an IOMMU is present, and

whether the root partition has VSM privileges. The IOMMU is very important for VSM. Refer to Chapter 9 for more information.) This phase also sets the encrypted hypervisor crash dump area, copies the VSM encryption keys, and transfers execution to the Secure Kernel entry point (*SkiSystemStartup*). The Secure Kernel entry point code runs in VTL 0. VTL 1 is started by the Secure Kernel code in later stages through the *HvCallEnablePartitionVtl* hypercall. (Read Chapter 9 for more details.)

VSM startup policy

At startup time, the Windows loader needs to determine whether it has to launch the Virtual Secure Mode (VSM). To defeat all the malware attempts to disable this new layer of protection, the system uses a specific policy to seal the VSM startup settings. In the default configurations, at the first boot (after the Windows Setup application has finished to copy the Windows files), the Windows Loader uses the *Os!SetVsmPolicy* routine to read and seal the VSM configuration, which is stored in the VSM root registry key *HKLM\SYSTEM\CurrentControlSet\Control\DeviceGuard*.

VSM can be enabled by different sources:

- **Device Guard Scenarios** Each scenario is stored as a subkey in the VSM root key. The *Enabled* DWORD registry value controls whether a scenario is enabled. If one or more scenarios are active, the VSM is enabled.
- **Global Settings** Stored in the *EnableVirtualizationBasedSecurity* registry value.
- **HVCI Code Integrity policies** Stored in the code integrity policy file (Policy.p7b).

Also, by default, VSM is automatically enabled when the hypervisor is enabled (except if the *HyperVVirtualizationBasedSecurityOptOut* registry value exists).

Every VSM activation source specifies a locking policy. If the locking mode is enabled, the Windows loader builds a Secure Boot variable, called *VbsPolicy*, and stores in it the VSM activation mode and the platform configuration. Part of the VSM platform configuration is dynamically generated based on the detected system hardware, whereas another part is read from the *RequirePlatformSecurityFeatures* registry value stored in the VSM root key. The Secure Boot variable is read at every subsequent boot; the configuration stored in the variable always replaces the configuration located in the Windows registry.

In this way, even if malware can modify the Windows Registry to disable VSM, Windows will simply ignore the change and keep the user environment secure. Malware won't be able to modify the VSM Secure Boot variable because, per Secure Boot specification, only a new variable signed by a trusted digital signature can modify or delete the original one. Microsoft provides a special signed tool that could disable the VSM protection. The tool is a special EFI boot application, which sets another signed Secure Boot variable called *VbsPolicyDisabled*. This variable is recognized at startup time by the Windows Loader. If it exists, Winload deletes the *VbsPolicy* secure variable and modifies the registry to disable VSM (modifying both the global settings and each Scenario activation).

EXPERIMENT: Understanding the VSM policy

In this experiment, you examine how the Secure Kernel startup is resistant to external tampering. First, enable Virtualization Based Security (VBS) in a compatible edition of Windows (usually the Pro and Business editions work well). On these SKUs, you can quickly verify whether VBS is enabled using Task Manager; if VBS is enabled, you should see a process named Secure System on the **Details** tab. Even if it's already enabled, check that the UEFI lock is enabled. Type **Edit Group policy** (or **gpedit.msc**) in the Start menu search box, and start the Local Policy Group Editor snap-in. Navigate to Computer Configuration, Administrative Templates, System, Device Guard, and double-click **Turn On Virtualization Based Security**. Make sure that the policy is set to **Enabled** and that the options are set as in the following figure:

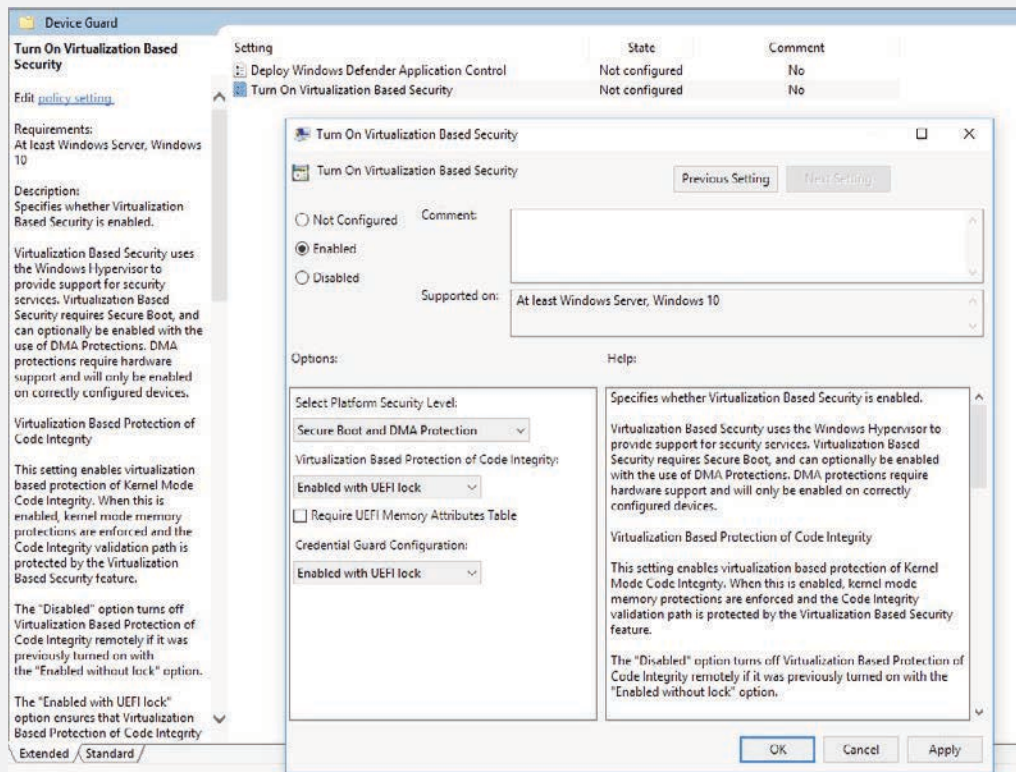

Make sure that Secure Boot is enabled (you can use the System Information utility or your system BIOS configuration tool to confirm the Secure Boot activation), and restart the system. The Enabled With UEFI Lock option provides antitampering even in an Administrator context. After your system is restarted, disable VBS through the same Group policy editor (make sure that all the settings are disabled) and by deleting all the registry keys and values located in HKEY_LOCAL_MACHINE\SYSTEM\CurrentControlSet\Control\DeviceGuard (setting them to 0 produces the same effect). Use the registry editor to properly delete all the values:

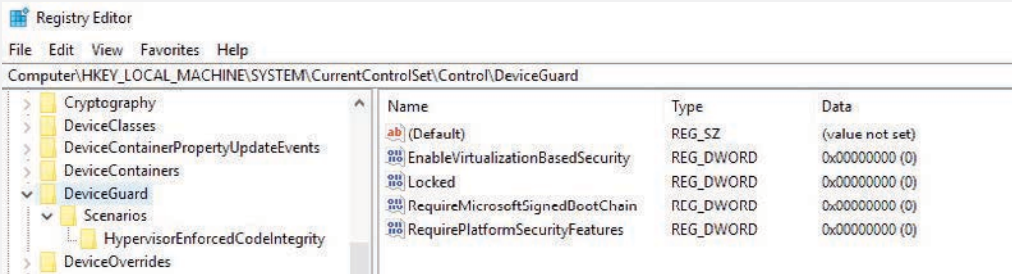

Disable the hypervisor by running `bcdedit /set {current} hypervisorlaunchtype off` from an elevated command prompt. Then restart your computer again. After the system is restarted, even if VBS and hypervisor are expected to be turned off, you should see that the Secure System and Lsalso process are still present in the Task Manager. This is because the UEFI secure variable *VbsPolicy* still contains the original policy, so a malicious program or a user could not easily disable the additional layer of protection. To properly confirm this, open the system event viewer by typing `eventvwr` and navigate to Windows Logs, System. If you scroll between the events, you should see the event that describes the VBS activation type (the event has Kernel-Boot source).

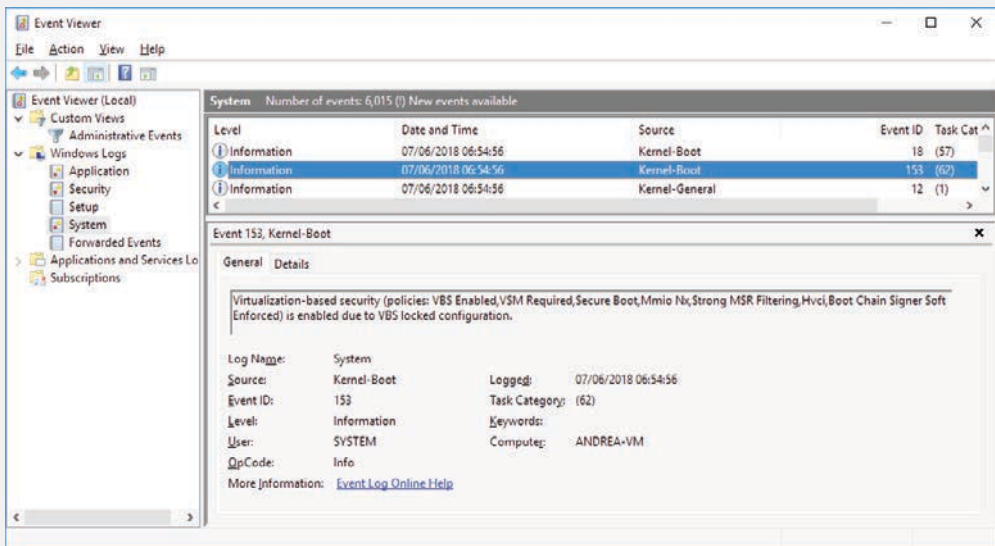

VbsPolicy is a Boot Services–authenticated UEFI variable, so this means it’s not visible after the OS switches to Runtime mode. The UefiTool utility, used in the previous experiment, is not able to show these kinds of variables. To properly examine the *VBSPolicy* variable content, restart your computer again, disable Secure Boot, and use the Efi Shell. The Efi Shell (found in this book’s downloadable resources, or downloadable from <https://github.com/tianocore/edk2/tree/UDK2018/ShellBinPkg/UefiShell/X64>) must be copied into a FAT32 USB stick in a file named *bootx64.efi* and located into the *efi\boot* path. At this point, you will be able to boot from the USB stick, which will launch the Efi Shell. Run the following command:

```
dmpstore VbsPolicy -guid 77FA9ABD-0359-4D32-BD60-28F4E78F784B
```

(*77FA9ABD-0359-4D32-BD60-28F4E78F784B* is the GUID of the Secure Boot private namespace.)

```
UEFI Interactive Shell v2.2
EDK II
UEFI v2.31 (Microsoft, Inc., 0x00010000)
Mapping Table
FS0: Alias(s): HD0a0a2::BLK2:
    PciRoot(0x0)/Pci(0x11,0x0)/Pci(0x4,0x0)/Sata(0x0,0x0,0x0)/HD(2,GPT,593D1320-AB00-49AF-BB8B-AC9A9CC4E6EF,0xF8000,0x31800)
FS1: Alias(s): HD1a0b::BLK7:
    PciRoot(0x0)/Pci(0x16,0x0)/Pci(0x0,0x0)/USB(0x0,0x0)/HD(1,MBR,0x10207431,0x000,0x1CE0000)
BLK0: Alias(s):
    PciRoot(0x0)/Pci(0x11,0x0)/Pci(0x4,0x0)/Sata(0x0,0x0,0x0)
BLK5: Alias(s):
    PciRoot(0x0)/Pci(0x11,0x0)/Pci(0x4,0x0)/Sata(0x1,0x0,0x0)
BLK1: Alias(s):
    PciRoot(0x0)/Pci(0x11,0x0)/Pci(0x4,0x0)/Sata(0x0,0x0,0x0)/HD(1,GPT,8DD697EE-640D-4DC1-9A13-D16D1D2574DE,0x000,0xF9000)
BLK3: Alias(s):
    PciRoot(0x0)/Pci(0x11,0x0)/Pci(0x4,0x0)/Sata(0x0,0x0,0x0)/HD(3,GPT,CF1D3393-8B8F-47AD-8A5A-BD714066C4D,0x12800,0x8000)
BLK4: Alias(s):
    PciRoot(0x0)/Pci(0x11,0x0)/Pci(0x4,0x0)/Sata(0x0,0x0,0x0)/HD(4,GPT,92C43F04-D15F-4746-8DE4-3F45593DBDD5,0x13800,0x13ECC000)
BLK6: Alias(s):
    PciRoot(0x0)/Pci(0x16,0x0)/Pci(0x0,0x0)/AESB(0x0,0x0)
Press ESC in 1 seconds to skip startup.nsh or any other key to continue.
Shell> dmpstore VbsPolicy -guid 77FA9ABD-0359-4D32-BD60-28F4E78F784B
Variable Name: '77FA9ABD-0359-4D32-BD60-28F4E78F784B:VbsPolicy' DataSize = 0x00
00000000: 02 00 00 00 07 02 00 00- *.....*
Shell> _
```

The Secure Launch

If Trusted Execution is enabled (through a specific feature value in the VSM policy) and the system is compatible, Winload enables a new boot path that’s a bit different compared to the normal one. This new boot path is called Secure Launch. Secure Launch implements the Intel Trusted Boot (TXT) technology (or SKINIT in AMD64 machines). Trusted Boot is implemented in two components: boot library and the *TcbLaunch.exe* file. The Boot library, at initialization time, detects that Trusted Boot is enabled and registers a boot callback that intercepts different events: Boot application starting, hash calculation, and Boot application ending. The Windows loader, in the early stages, executes to the three stages of Secure Launch Setup (from now on we call the Secure Launch setup the TCB setup) instead of loading the hypervisor.

As previously discussed, the final goal of Secure Launch is to start a secure boot sequence, where the CPU is the only root of trust. To do so, the system needs to get rid of all the firmware dependencies.

Windows achieves this by creating a RAM disk formatted with the FAT file system, which includes Winload, the hypervisor, the VSM module, and all the boot OS components needed to start the system. The windows loader (Winload) reads TcbLaunch.exe from the system boot disk into memory, using the *BllmgLoadBootApplication* routine. The latter triggers the three events that the TCB boot callback manages. The callback first prepares the Measured Launch Environment (MLE) for launch, checking the ACM modules, ACPI table, and mapping the required TXT regions; then it replaces the boot application entry point with a special TXT MLE routine.

The Windows Loader, in the latest stages of the *OslExecuteTransition* routine, doesn't start the hypervisor launch sequence. Instead, it transfers the execution to the TCB launch sequence, which is quite simple. The TCB boot application is started with the same *BllmgStartBootApplication* routine described in the previous paragraph. The modified boot application entry point calls the TXT MLE launch routine, which executes the GETSEC(SENTER) TXT instruction. This instruction measures the TcbLaunch.exe executable in memory (TBOOT module) and if the measurement succeeds, the MLE launch routine transfers the code execution to the real boot application entry point (*TcbMain*).

TcbMain function is the first code executed in the Secure Launch environment. The implementation is simple: reinitialize the Boot Library, register an event to receive virtualization launch/resume notification, and call *TcbLoadEntry* from the Tcbloader.dll module located in the secure RAM disk. The Tcbloader.dll module is a mini version of the trusted Windows loader. Its goal is to load, verify, and start the hypervisor; set up the Hypercall page; and launch the Secure Kernel. The Secure Launch at this stage ends because the hypervisor and Secure Kernel take care of the verification of the NT kernel and other modules, providing the chain of trust. Execution then returns to the Windows loader, which moves to the Windows kernel through the standard *OslArchTransferToKernel* routine.

Figure 12-10 shows a scheme of Secure Launch and all its involved components. The user can enable the Secure Launch by using the Local Group policy editor (by tweaking the Turn On Virtualization Based Security setting, which is under Computer Configuration, Administrative Templates, System, Device Guard).

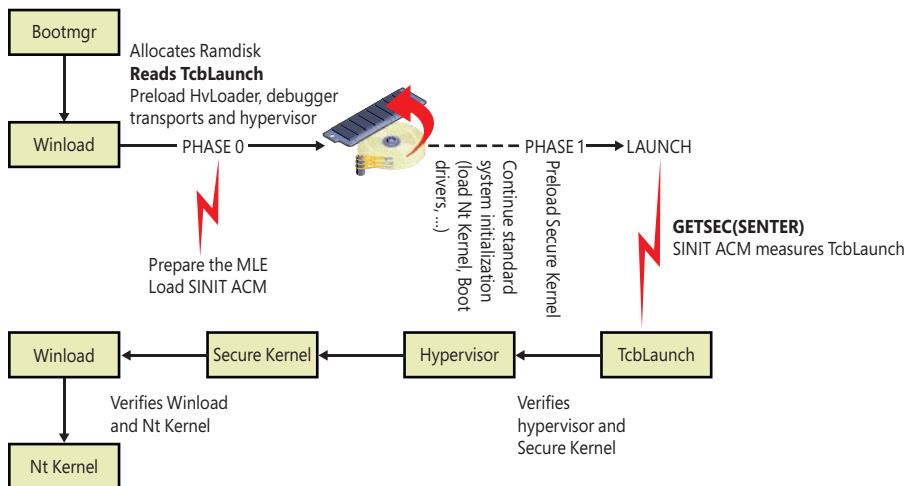

FIGURE 12-10 The Secure Launch scheme. Note that the hypervisor and Secure Kernel start from the RAM disk.



Note The ACM modules of Trusted Boot are provided by Intel and are chipset-dependent. Most of the TXT interface is memory mapped in physical memory. This means that the Hv Loader can access even the SINIT region, verify the SINIT ACM version, and update it if needed. Windows achieves this by using a special compressed WIM file (called *Tcbres.wim*) that contains all the known SINIT ACM modules for each chipset. If needed, the MLE preparation phase opens the compressed file, extracts the right binary module, and replaces the contents of the original SINIT firmware in the TXT region. When the Secure Launch procedure is invoked, the CPU loads the SINIT ACM into secure memory, verifies the integrity of the digital signature, and compares the hash of its public key with the one hardcoded into the chipset.

Secure Launch on AMD platforms

Although Secure Launch is supported on Intel machines thanks to TXT, the Windows 10 Spring 2020 update also supports SKINIT, which is a similar technology designed by AMD for the verifiable startup of trusted software, starting with an initially untrusted operating mode.

SKINIT has the same goal as Intel TXT and is used for the Secure Launch boot flow. It's different from the latter, though: The base of SKINIT is a small type of software called secure loader (SL), which in Windows is implemented in the *amdsl.bin* binary included in the resource section of the *Amddrtm.dll* library provided by AMD. The SKINIT instruction reinitializes the processor to establish a secure execution environment and starts the execution of the SL in a way that can't be tampered with. The secure loader lives in the Secure Loader Block, a 64-Kbyte structure that is transferred to the TPM by the SKINIT instruction. The TPM measures the integrity of the SL and transfers execution to its entry point.

The SL validates the system state, extends measurements into the PCR, and transfers the execution to the AMD MLE launch routine, which is located in a separate binary included in the *TcbLaunch.exe* module. The MLE routine initializes the IDT and GDT and builds the page table for switching the processor to long mode. (The MLE in AMD machines are executed in 32-bit protected mode, with a goal of keeping the code in the TCB as small as possible.) It finally jumps back in the *TcbLaunch*, which, as for Intel systems, reinitializes the Boot Library, registers an event to receive virtualization launch/resume notification, and calls *TcbLoadEntry* from the *tcbloader.dll* module. From now on, the boot flow is identical to the Secure Launch implementation for the Intel systems.

Initializing the kernel and executive subsystems

When *Winload* calls *Ntoskrnl*, it passes a data structure called the Loader Parameter block. The Loader Parameter block contains the system and boot partition paths, a pointer to the memory tables *Winload* generated to describe the system physical memory, a physical hardware tree that is later used to build the volatile HARDWARE registry hive, an in-memory copy of the SYSTEM registry hive, and a pointer to the list of boot drivers *Winload* loaded. It also includes various other information related to the boot processing performed until this point.

EXPERIMENT: Loader Parameter block

While booting, the kernel keeps a pointer to the Loader Parameter block in the *KeLoaderBlock* variable. The kernel discards the parameter block after the first boot phase, so the only way to see the contents of the structure is to attach a kernel debugger before booting and break at the initial kernel debugger breakpoint. If you're able to do so, you can use the **dt** command to dump the block, as shown:

```
kd> dt poi(nt!KeLoaderBlock) nt!LOADER_PARAMETER_BLOCK
+0x000 OsMajorVersion : 0xa
+0x004 OsMinorVersion : 0
+0x008 Size : 0x160
+0x00c OsLoaderSecurityVersion : 1
+0x010 LoadOrderListHead : _LIST_ENTRY [ 0xfffff800`2278a230 - 0xfffff800`2288c150 ]
+0x020 MemoryDescriptorListHead : _LIST_ENTRY [ 0xfffff800`22949000 - 0xfffff800`22949de8 ]
+0x030 BootDriverListHead : _LIST_ENTRY [ 0xfffff800`22840f50 - 0xfffff800`2283f3e0 ]
+0x040 EarlyLaunchListHead : _LIST_ENTRY [ 0xfffff800`228427f0 - 0xfffff800`228427f0 ]
+0x050 CoreDriverListHead : _LIST_ENTRY [ 0xfffff800`228429a0 - 0xfffff800`228405a0 ]
+0x060 CoreExtensionsDriverListHead : _LIST_ENTRY [ 0xfffff800`2283ff20 - 0xfffff800`22843090 ]
+0x070 TpmCoreDriverListHead : _LIST_ENTRY [ 0xfffff800`22831ad0 - 0xfffff800`22831ad0 ]
+0x080 KernelStack : 0xfffff800`25f5e000
+0x088 Prcb : 0xfffff800`22acf180
+0x090 Process : 0xfffff800`23c819c0
+0x098 Thread : 0xfffff800`23c843c0
+0x0a0 KernelStackSize : 0x6000
+0x0a4 RegistryLength : 0xb80000
+0x0a8 RegistryBase : 0xfffff800`22b49000 Void
+0x0b0 ConfigurationRoot : 0xfffff800`22783090 _CONFIGURATION_COMPONENT_DATA
+0x0b8 ArcBootDeviceName : 0xfffff800`22785290 "multi(0)disk(0)rdisk(0)partition(4)"
+0x0c0 ArcHalDeviceName : 0xfffff800`22785190 "multi(0)disk(0)rdisk(0)partition(2)"
+0x0c8 NtBootPathName : 0xfffff800`22785250 "\\WINDOWS\\"
+0x0d0 NtHalPathName : 0xfffff800`22782bd0 ""
+0x0d8 LoadOptions : 0xfffff800`22772c80 "KERNEL=NTKRNLMP.EXE NOEXECUTE=OPTIN
HYPERVISORLAUNCHTYPE=AUTO DEBUG ENCRYPTION_KEY=**** DEBUGPORT=NET
HOST_IP=192.168.18.48 HOST_PORT=50000 NOVGA"
+0x0e0 NlsData : 0xfffff800`2277a450 _NLS_DATA_BLOCK
+0x0e8 ArcDiskInformation : 0xfffff800`22785e30 _ARC_DISK_INFORMATION
+0x0f0 Extension : 0xfffff800`2275cf90 _LOADER_PARAMETER_EXTENSION
+0x0f8 u : <unnamed-tag>
+0x108 FirmwareInformation : _FIRMWARE_INFORMATION_LOADER_BLOCK
+0x148 OsBootstatPathName : (null)
+0x150 ArcOSDataDeviceName : (null)
+0x158 ArcWindowsSysPartName : (null)
```

Additionally, you can use the **!loadermemorylist** command on the *MemoryDescriptorListHead* field to dump the physical memory ranges:

```
kd> !loadermemorylist 0xfffff800`22949000
Base Length Type
0000000001 0000000005 (26) HALCachedMemory ( 20 Kb )
0000000006 000000009a ( 5) FirmwareTemporary ( 616 Kb )
...
```



```

000001304 0000000001 ( 7) OsloaderHeap ( 4 Kb )
000001305 0000000081 ( 5) FirmwareTemporary ( 516 Kb )
000001386 000000001c (20) MemoryData ( 112 Kb )
...
000001800 0000000b80 (19) RegistryData ( 11 Mb 512 Kb )
000002380 00000009fe ( 9) SystemCode ( 9 Mb 1016 Kb )
000002d7e 0000000282 ( 2) Free ( 2 Mb 520 Kb )
000003000 0000000391 ( 9) SystemCode ( 3 Mb 580 Kb )
000003391 0000000068 (11) BootDriver ( 416 Kb )
0000033f9 0000000257 ( 2) Free ( 2 Mb 348 Kb )
000003650 00000008d2 ( 5) FirmwareTemporary ( 8 Mb 840 Kb )
000007ffc9 0000000026 (31) FirmwareData ( 152 Kb )
000007ffef 0000000004 (32) FirmwareReserved ( 16 Kb )
000007fff3 000000000c ( 6) FirmwarePermanent ( 48 Kb )
000007ffff 0000000001 ( 5) FirmwareTemporary ( 4 Kb )
NumberOfDescriptors: 90

```

Summary

Memory Type	Pages		
Free	000007a89c (501916)	(1 Gb 936 Mb 624 Kb)	
LoadedProgram	0000000370 (880)	(3 Mb 448 Kb)	
FirmwareTemporary	0000001fd4 (8148)	(31 Mb 848 Kb)	
FirmwarePermanent	000000030e (782)	(3 Mb 56 Kb)	
OsloaderHeap	0000000275 (629)	(2 Mb 468 Kb)	
SystemCode	0000001019 (4121)	(16 Mb 100 Kb)	
BootDriver	000000115a (4442)	(17 Mb 360 Kb)	
RegistryData	0000000b88 (2952)	(11 Mb 544 Kb)	
MemoryData	0000000098 (152)	(608 Kb)	
NlsData	0000000023 (35)	(140 Kb)	
HALCachedMemory	0000000005 (5)	(20 Kb)	
FirmwareCode	0000000008 (8)	(32 Kb)	
FirmwareData	0000000075 (117)	(468 Kb)	
FirmwareReserved	0000000044 (68)	(272 Kb)	
=====			
Total	000007FFDF (524255)	= (~2047 Mb)	

The Loader Parameter extension can show useful information about the system hardware, CPU features, and boot type:

```

kd> dt poi(nt!KeLoaderBlock) nt!LOADER_PARAMETER_BLOCK Extension
+0x0f0 Extension : 0xfffff800`2275cf90 _LOADER_PARAMETER_EXTENSION
kd> dt 0xfffff800`2275cf90 _LOADER_PARAMETER_EXTENSION
nt!_LOADER_PARAMETER_EXTENSION
+0x000 Size : 0xc48
+0x004 Profile : _PROFILE_PARAMETER_BLOCK
+0x018 EmInffileImage : 0xfffff800`25f2d000 Void
...
+0x068 AcpiTable : (null)
+0x070 AcpiTableSize : 0
+0x074 LastBootSucceeded : 0y1
+0x074 LastBootShutdown : 0y1
+0x074 IoPortAccessSupported : 0y1
+0x074 BootDebuggerActive : 0y0
+0x074 StrongCodeGuarantees : 0y0
+0x074 HardStrongCodeGuarantees : 0y0
+0x074 SidSharingDisabled : 0y0

```

```

+0x074 TpmInitialized      : 0y0
+0x074 VsmConfigured      : 0y0
+0x074 IumEnabled         : 0y0
+0x074 IsSmbboot         : 0y0
+0x074 BootLogEnabled     : 0y0
+0x074 FeatureSettings    : 0y0000000 (0)
+0x074 FeatureSimulations : 0y0000000 (0)
+0x074 MicrocodeSelfHosting : 0y0
...
+0x900 BootFlags          : 0
+0x900 DbgMenuOsSelection : 0y0
+0x900 DbgHiberBoot       : 0y1
+0x900 DbgSoftRestart     : 0y0
+0x908 InternalBootFlags  : 2
+0x908 DbgUtcBootTime     : 0y0
+0x908 DbgRtcBootTime     : 0y1
+0x908 DbgNoLegacyServices : 0y0

```

Ntoskrnl then begins phase 0, the first of its two-phase initialization process (phase 1 is the second). Most executive subsystems have an initialization function that takes a parameter that identifies which phase is executing.

During phase 0, interrupts are disabled. The purpose of this phase is to build the rudimentary structures required to allow the services needed in phase 1 to be invoked. Ntoskrnl's startup function, *KiSystemStartup*, is called in each system processor context (more details later in this chapter in the "Kernel initialization phase 1" section). It initializes the processor boot structures and sets up a Global Descriptor Table (GDT) and Interrupt Descriptor Table (IDT). If called from the boot processor, the startup routine initializes the Control Flow Guard (CFG) check functions and cooperates with the memory manager to initialize KASLR. The KASLR initialization should be done in the early stages of the system startup; in this way, the kernel can assign random VA ranges for the various virtual memory regions (such as the PFN database and system PTE regions; more details about KASLR are available in the "Image randomization" section of Chapter 5, Part 1). *KiSystemStartup* also initializes the kernel debugger, the XSAVE processor area, and, where needed, KVA Shadow. It then calls *KiInitializeKernel*. If *KiInitializeKernel* is running on the boot CPU, it performs systemwide kernel initialization, such as initializing internal lists and other data structures that all CPUs share. It builds and compacts the System Service Descriptor table (SSDT) and calculates the random values for the internal *KiWaitAlways* and *KiWaitNever* values, which are used for kernel pointers encoding. It also checks whether virtualization has been started; if it has, it maps the Hypercall page and starts the processor's enlightenments (more details about the hypervisor enlightenments are available in Chapter 9).

KiInitializeKernel, if executed by compatible processors, has the important role of initializing and enabling the Control Enforcement Technology (CET). This hardware feature is relatively new, and basically implements a hardware shadow stack, used to detect and prevent ROP attacks. The technology is used for protecting both user-mode applications as well as kernel-mode drivers (only when VSM is available). *KiInitializeKernel* initializes the Idle process and thread and calls *ExpInitializeExecutive*. *KiInitializeKernel* and *ExpInitializeExecutive* are normally executed on each system processor. When

executed by the boot processor, *ExpInitializeExecutive* relies on the function responsible for orchestrating phase 0, *InitBootProcessor*, while subsequent processors call only *InitOtherProcessors*.



Note Return-oriented programming (ROP) is an exploitation technique in which an attacker gains control of the call stack of a program with the goal of hijacking its control flow and executes carefully chosen machine instruction sequences, called “gadgets,” that are already present in the machine’s memory. Chained together, multiple gadgets allow an attacker to perform arbitrary operations on a machine.

InitBootProcessor starts by validating the boot loader. If the boot loader version used to launch Windows doesn’t correspond to the right Windows kernel, the function crashes the system with a *LOADER_BLOCK_MISMATCH* bugcheck code (0x100). Otherwise, it initializes the pool look-aside pointers for the initial CPU and checks for and honors the BCD *burnmemory* boot option, where it discards the amount of physical memory the value specifies. It then performs enough initialization of the NLS files that were loaded by Winload (described earlier) to allow Unicode to ANSI and OEM translation to work. Next, it continues by initializing Windows Hardware Error Architecture (WHEA) and calling the HAL function *HallnitSystem*, which gives the HAL a chance to gain system control before Windows performs significant further initialization. *HallnitSystem* is responsible for initializing and starting various components of the HAL, like ACPI tables, debugger descriptors, DMA, firmware, I/O MMU, System Timers, CPU topology, performance counters, and the PCI bus. One important duty of *HallnitSystem* is to prepare each CPU interrupt controller to receive interrupts and to configure the interval clock timer interrupt, which is used for CPU time accounting. (See the section “Quantum” in Chapter 4, “Threads,” in Part 1 for more on CPU time accounting.)

When *HallnitSystem* exits, *InitBootProcessor* proceeds by computing the reciprocal for clock timer expiration. Reciprocals are used for optimizing divisions on most modern processors. They can perform multiplications faster, and because Windows must divide the current 64-bit time value in order to find out which timers need to expire, this static calculation reduces interrupt latency when the clock interval fires. *InitBootProcessor* uses a helper routine, *CmlnitSystem0*, to fetch registry values from the control vector of the SYSTEM hive. This data structure contains more than 150 kernel-tuning options that are part of the HKLM\SYSTEM\CurrentControlSet\Control registry key, including information such as the licensing data and version information for the installation. All the settings are preloaded and stored in global variables. *InitBootProcessor* then continues by setting up the system root path and searching into the kernel image to find the crash message strings it displays on blue screens, caching their location to avoid looking them up during a crash, which could be dangerous and unreliable. Next, *InitBootProcessor* initializes the timer subsystem and the shared user data page.

InitBootProcessor is now ready to call the phase 0 initialization routines for the executive, Driver Verifier, and the memory manager. These components perform the following initialization tasks:

1. The executive initializes various internal locks, resources, lists, and variables and validates that the product suite type in the registry is valid, discouraging casual modification of the registry to “upgrade” to an SKU of Windows that was not actually purchased. This is only one of the many such checks in the kernel.

2. Driver Verifier, if enabled, initializes various settings and behaviors based on the current state of the system (such as whether safe mode is enabled) and verification options. It also picks which drivers to target for tests that target randomly chosen drivers.
3. The memory manager constructs the page tables, PFN database, and internal data structures that are necessary to provide basic memory services. It also enforces the limit of the maximum supported amount of physical memory and builds and reserves an area for the system file cache. It then creates memory areas for the paged and nonpaged pools (described in Chapter 5 in Part 1). Other executive subsystems, the kernel, and device drivers use these two memory pools for allocating their data structures. It finally creates the UltraSpace, a 16 TB region that provides support for fast and inexpensive page mapping that doesn't require TLB flushing.

Next, *InitBootProcessor* enables the hypervisor CPU dynamic partitioning (if enabled and correctly licensed), and calls *HallInitializeBios* to set up the old BIOS emulation code part of the HAL. This code is used to allow access (or to emulate access) to 16-bit real mode interrupts and memory, which are used mainly by Bootvid (this driver has been replaced by BGFX but still exists for compatibility reasons).

At this point, *InitBootProcessor* enumerates the boot-start drivers that were loaded by Winload and calls *DbgLoadImageSymbols* to inform the kernel debugger (if attached) to load symbols for each of these drivers. If the host debugger has configured the break on symbol load option, this will be the earliest point for a kernel debugger to gain control of the system. *InitBootProcessor* now calls *HvlPhase1Initialize*, which performs the remaining HVL initialization that hasn't been possible to complete in previous phases. When the function returns, it calls *HeadlessInit* to initialize the serial console if the machine was configured for Emergency Management Services (EMS).

Next, *InitBootProcessor* builds the versioning information that will be used later in the boot process, such as the build number, service pack version, and beta version status. Then it copies the NLS tables that Winload previously loaded into the paged pool, reinitializes them, and creates the kernel stack trace database if the global flags specify creating one. (For more information on the global flags, see Chapter 6, "I/O system," in Part 1.)

Finally, *InitBootProcessor* calls the object manager, security reference monitor, process manager, user-mode debugging framework, and Plug and Play manager. These components perform the following initialization steps:

1. During the object manager initialization, the objects that are necessary to construct the object manager namespace are defined so that other subsystems can insert objects into it. The system process and the global kernel handle tables are created so that resource tracking can begin. The value used to encrypt the object header is calculated, and the Directory and SymbolicLink object types are created.
2. The security reference monitor initializes security global variables (like the system SIDs and Privilege LUIDs) and the in-memory database, and it creates the token type object. It then creates and prepares the first local system account token for assignment to the initial process. (See Chapter 7 in Part 1 for a description of the local system account.)
3. The process manager performs most of its initialization in phase 0, defining the process, thread, job, and partition object types and setting up lists to track active processes and threads. The

systemwide process mitigation options are initialized and merged with the options specified in the HKLM\SYSTEM\CurrentControlSet\Control\Session Manager\Kernel\MitigationOptions registry value. The process manager then creates the executive system partition object, which is called MemoryPartition0. The name is a little misleading because the object is actually an executive partition object, a new Windows object type that encapsulates a memory partition and a cache manager partition (for supporting the new application containers).

4. The process manager also creates a process object for the initial process and names it idle. As its last step, the process manager creates the *System* protected process and a system thread to execute the routine *Phase1Initialization*. This thread doesn't start running right away because interrupts are still disabled. The *System* process is created as protected to get protection from user mode attacks, because its virtual address space is used to map sensitive data used by the system and by the Code Integrity driver. Furthermore, kernel handles are maintained in the system process's handle table.
5. The user-mode debugging framework creates the definition of the debug object type that is used for attaching a debugger to a process and receiving debugger events. For more information on user-mode debugging, see Chapter 8, "System mechanisms."
6. The Plug and Play manager's phase 0 initialization then takes place, which involves initializing an executive resource used to synchronize access to bus resources.

When control returns to *KiInitializeKernel*, the last step is to allocate the DPC stack for the current processor, raise the IRQL to dispatch level, and enable the interrupts. Then control proceeds to the Idle loop, which causes the system thread created in step 4 to begin executing phase 1. (Secondary processors wait to begin their initialization until step 11 of phase 1, which is described in the following list.)

Kernel initialization phase 1

As soon as the Idle thread has a chance to execute, phase 1 of kernel initialization begins. Phase 1 consists of the following steps:

1. *Phase1InitializationDiscard*, as the name implies, discards the code that is part of the INIT section of the kernel image in order to preserve memory.
2. The initialization thread sets its priority to 31, the highest possible, to prevent preemption.
3. The BCD option that specifies the maximum number of virtual processors (*hypervisorrootproc*) is evaluated.
4. The NUMA/group topology relationships are created, in which the system tries to come up with the most optimized mapping between logical processors and processor groups, taking into account NUMA localities and distances, unless overridden by the relevant BCD settings.
5. *HallnitSystem* performs phase 1 of its initialization. It prepares the system to accept interrupts from external peripherals.
6. The system clock interrupt is initialized, and the system clock tick generation is enabled.

7. The old boot video driver (*bootvid*) is initialized. It's used only for printing debug messages and messages generated by native applications launched by SMSS, such as the NT *chkdsk*.
8. The kernel builds various strings and version information, which are displayed on the boot screen through *Bootvid* if the *sos* boot option was enabled. This includes the full version information, number of processors supported, and amount of memory supported.
9. The power manager's initialization is called.
10. The system time is initialized (by calling *HalQueryRealTimeClock*) and then stored as the time the system booted.
11. On a multiprocessor system, the remaining processors are initialized by *KeStartAllProcessors* and *HalAllProcessorsStarted*. The number of processors that will be initialized and supported depends on a combination of the actual physical count, the licensing information for the installed SKU of Windows, boot options such as *numproc* and *bootproc*, and whether dynamic partitioning is enabled (server systems only). After all the available processors have initialized, the affinity of the system process is updated to include all processors.
12. The object manager initializes the global system silo, the per-processor nonpaged lookaside lists and descriptors, and base auditing (if enabled by the system control vector). It then creates the namespace root directory (**), *\KernelObjects* directory, *\ObjectTypes* directory, and the DOS device name mapping directory (*\Global??*), with the *Global* and *GLOBALROOT* links created in it. The object manager then creates the silo device map that will control the DOS device name mapping and attach it to the system process. It creates the old *\DosDevices* symbolic link (maintained for compatibility reasons) that points to the Windows subsystem device name mapping directory. The object manager finally inserts each registered object type in the *\ObjectTypes* directory object.
13. The executive is called to create the executive object types, including semaphore, mutex, event, timer, keyed event, push lock, and thread pool worker.
14. The I/O manager is called to create the I/O manager object types, including device, driver, controller, adapter, I/O completion, wait completion, and file objects.
15. The kernel initializes the system watchdogs. There are two main types of watchdog: the DPC watchdog, which checks that a DPC routine will not execute more than a specified amount of time, and the CPU Keep Alive watchdog, which verifies that each CPU is always responsive. The watchdogs aren't initialized if the system is executed by a hypervisor.
16. The kernel initializes each CPU processor control block (KPRCB) data structure, calculates the Numa cost array, and finally calculates the System Tick and Quantum duration.
17. The kernel debugger library finalizes the initialization of debugging settings and parameters, regardless of whether the debugger has not been triggered prior to this point.
18. The transaction manager also creates its object types, such as the enlistment, resource manager, and transaction manager types.
19. The user-mode debugging library (*Dbgk*) data structures are initialized for the global system silo.

20. If driver verifier is enabled and, depending on verification options, pool verification is enabled, object handle tracing is started for the system process.
21. The security reference monitor creates the \Security directory in the object manager namespace, protecting it with a security descriptor in which only the SYSTEM account has full access, and initializes auditing data structures if auditing is enabled. Furthermore, the security reference monitor initializes the kernel-mode SDDL library and creates the event that will be signaled after the LSA has initialized (\Security\LSA_AUTHENTICATION_INITIALIZED).

Finally, the Security Reference Monitor initializes the Kernel Code Integrity component (Ci.dll) for the first time by calling the internal *CiInitialize* routine, which initializes all the Code Integrity Callbacks and saves the list of boot drivers for further auditing and verification.
22. The process manager creates a system handle for the executive system partition. The handle will never be dereferenced, so as a result the system partition cannot be destroyed. The Process Manager then initializes the support for kernel optional extension (more details are in step 26). It registers host callouts for various OS services, like the Background Activity Moderator (BAM), Desktop Activity Moderator (DAM), Multimedia Class Scheduler Service (MMCSS), Kernel Hardware Tracing, and Windows Defender System Guard.

Finally, if VSM is enabled, it creates the first minimal process, the IUM System Process, and assigns it the name Secure System.
23. The \SystemRoot symbolic link is created.
24. The memory manager is called to perform phase 1 of its initialization. This phase creates the Section object type, initializes all its associated data structures (like the control area), and creates the \Device\PhysicalMemory section object. It then initializes the kernel Control Flow Guard support and creates the pagefile-backed sections that will be used to describe the user mode CFG bitmap(s). (Read more about Control Flow Guard in Chapter 7, Part 1.) The memory manager initializes the Memory Enclave support (for SGX compatible systems), the hot-patch support, the page-combining data structures, and the system memory events. Finally, it spawns three memory manager system worker threads (Balance Set Manager, Process Swapper, and Zero Page Thread, which are explained in Chapter 5 of Part 1) and creates a section object used to map the API Set schema memory buffer in the system space (which has been previously allocated by the Windows Loader). The just-created system threads have the chance to execute later, at the end of phase 1.
25. NLS tables are mapped into system space so that they can be mapped easily by user-mode processes.
26. The cache manager initializes the file system cache data structures and creates its worker threads.
27. The configuration manager creates the \Registry key object in the object manager namespace and opens the in-memory SYSTEM hive as a proper hive file. It then copies the initial hardware tree data passed by Winload into the volatile HARDWARE hive.
28. The system initializes Kernel Optional Extensions. This functionality has been introduced in Windows 8.1 with the goal of exporting private system components and Windows loader data

(like memory caching requirements, UEFI runtime services pointers, UEFI memory map, SMBIOS data, secure boot policies, and Code Integrity data) to different kernel components (like the Secure Kernel) without using the standard PE (portable executable) exports.

29. The errata manager initializes and scans the registry for errata information, as well as the INF (driver installation file, described in Chapter 6 of Part 1) database containing errata for various drivers.
30. The manufacturing-related settings are processed. The manufacturing mode is a special operating system mode that can be used for manufacturing-related tasks, such as components and support testing. This feature is used especially in mobile systems and is provided by the UEFI subsystem. If the firmware indicates to the OS (through a specific UEFI protocol) that this special mode is enabled, Windows reads and writes all the needed information from the HKLM\System\CurrentControlSet\Control\ManufacturingMode registry key.
31. Superfetch and the prefetcher are initialized.
32. The Kernel Virtual Store Manager is initialized. The component is part of memory compression.
33. The VM Component is initialized. This component is a kernel optional extension used to communicate with the hypervisor.
34. The current time zone information is initialized and set.
35. Global file system driver data structures are initialized.
36. The NT Rtl compression engine is initialized.
37. The support for the hypervisor debugger, if needed, is set up, so that the rest of the system does not use its own device.
38. Phase 1 of debugger-transport-specific information is performed by calling the *KdDebuggerInitialize1* routine in the registered transport, such as Kdcom.dll.
39. The advanced local procedure call (ALPC) subsystem initializes the ALPC port type and ALPC waitable port type objects. The older LPC objects are set as aliases.
40. If the system was booted with boot logging (with the BCD *bootlog* option), the boot log file is initialized. If the system was booted in safe mode, it finds out if an alternate shell must be launched (as in the case of a safe mode with command prompt boot).
41. The executive is called to execute its second initialization phase, where it configures part of the Windows licensing functionality in the kernel, such as validating the registry settings that hold license data. Also, if persistent data from boot applications is present (such as memory diagnostic results or resume from hibernation information), the relevant log files and information are written to disk or to the registry.
42. The MiniNT/WinPE registry keys are created if this is such a boot, and the NLS object directory is created in the namespace, which will be used later to host the section objects for the various memory-mapped NLS files.

43. The Windows kernel Code Integrity policies (like the list of trusted signers and certificate hashes) and debugging options are initialized, and all the related settings are copied from the Loader Block to the kernel CI module (Ci.dll).
44. The power manager is called to initialize again. This time it sets up support for power requests, the power watchdogs, the ALPC channel for brightness notifications, and profile callback support.
45. The I/O manager initialization now takes place. This stage is a complex phase of system startup that accounts for most of the boot time.

The I/O manager first initializes various internal structures and creates the driver and device object types as well as its root directories: \Driver, \FileSystem, \FileSystem\Filters, and \UMDFCommunicationPorts (for the UMDF driver framework). It then initializes the Kernel Shim Engine, and calls the Plug and Play manager, power manager, and HAL to begin the various stages of dynamic device enumeration and initialization. (We covered all the details of this complex and specific process in Chapter 6 of Part 1.) Then the Windows Management Instrumentation (WMI) subsystem is initialized, which provides WMI support for device drivers. (See the section “Windows Management Instrumentation” in Chapter 10 for more information.) This also initializes Event Tracing for Windows (ETW) and writes all the boot persistent data ETW events, if any.

The I/O manager starts the platform-specific error driver and initializes the global table of hardware error sources. These two are vital components of the Windows Hardware Error infrastructure. Then it performs the first Secure Kernel call, asking the Secure Kernel to perform the last stage of its initialization in VTL 1. Also, the encrypted secure dump driver is initialized, reading part of its configuration from the Windows Registry (HKLM\System\CurrentControlSet\Control\CrashControl).

All the boot-start drivers are enumerated and ordered while respecting their dependencies and load-ordering. (Details on the processing of the driver load control information on the registry are also covered in Chapter 6 of Part 1.) All the linked kernel mode DLLs are initialized with the built-in RAW file system driver.

At this stage, the I/O manager maps Ntdll.dll, Vertdll.dll, and the WOW64 version of Ntdll into the system address space. Finally, all the boot-start drivers are called to perform their driver-specific initialization, and then the system-start device drivers are started. The Windows subsystem device names are created as symbolic links in the object manager's namespace.

46. The configuration manager registers and starts its Windows registry's ETW Trace Logging Provider. This allows the tracing of the entire configuration manager.
47. The transaction manager sets up the Windows software trace preprocessor (WPP) and registers its ETW Provider.
48. Now that boot-start and system-start drivers are loaded, the errata manager loads the INF database with the driver errata and begins parsing it, which includes applying registry PCI configuration workarounds.
49. If the computer is booting in safe mode, this fact is recorded in the registry.

50. Unless explicitly disabled in the registry, paging of kernel-mode code (in Ntoskrnl and drivers) is enabled.
51. The power manager is called to finalize its initialization.
52. The kernel clock timer support is initialized.
53. Before the INIT section of Ntoskrnl will be discarded, the rest of the licensing information for the system is copied into a private system section, including the current policy settings that are stored in the registry. The system expiration time is then set.
54. The process manager is called to set up rate limiting for jobs and the system process creation time. It initializes the static environment for protected processes, and looks up various system-defined entry points in the user-mode system libraries previously mapped by the I/O manager (usually Ntdll.dll, Ntdll32.dll, and Vertdll.dll).
55. The security reference monitor is called to create the Command Server thread that communicates with LSASS. This phase creates the Reference Monitor command port, used by LSA to send commands to the SRM. (See the section “Security system components” in Chapter 7 in Part 1 for more on how security is enforced in Windows.)
56. If the VSM is enabled, the encrypted VSM keys are saved to disk. The system user-mode libraries are mapped into the Secure System Process. In this way, the Secure Kernel receives all the needed information about the VTL 0’s system DLLs.
57. The Session Manager (Smss) process (introduced in Chapter 2, “System architecture,” in Part 1) is started. Smss is responsible for creating the user-mode environment that provides the visible interface to Windows—its initialization steps are covered in the next section.
58. The bootvid driver is enabled to allow the NT check disk tool to display the output strings.
59. The TPM boot entropy values are queried. These values can be queried only once per boot, and normally, the TPM system driver should have queried them by now, but if this driver has not been running for some reason (perhaps the user disabled it), the unqueried values would still be available. Therefore, the kernel also manually queries them to avoid this situation; in normal scenarios, the kernel’s own query should fail.
60. All the memory used by the loader parameter block and all its references (like the initialization code of Ntoskrnl and all boot drivers, which reside in the INIT sections) are now freed.

As a final step before considering the executive and kernel initialization complete, the phase 1 initialization thread sets the critical break on termination flag to the new Smss process. In this way, if the Smss process exits or gets terminated for some reason, the kernel intercepts this, breaks into the attached debugger (if any), and crashes the system with a *CRITICAL_PROCESS_DIED* stop code.

If the five-second wait times out (that is, if five seconds elapse), the Session Manager is assumed to have started successfully, and the phase 1 initialization thread exits. Thus, the boot processor executes one of the memory manager’s system threads created in step 22 or returns to the Idle loop.

Smss, Csrss, and Wininit

Smss is like any other user-mode process except for two differences. First, Windows considers Smss a trusted part of the operating system. Second, Smss is a *native* application. Because it's a trusted operating system component, Smss runs as a protected process light (PPL; PPLs are covered in Part 1, Chapter 3, "Processes and jobs") and can perform actions few other processes can perform, such as creating security tokens. Because it's a native application, Smss doesn't use Windows APIs—it uses only core executive APIs known collectively as the Windows native API (which are normally exposed by Ntdll). Smss doesn't use the Win32 APIs, because the Windows subsystem isn't executing when Smss launches. In fact, one of Smss's first tasks is to start the Windows subsystem.

Smss initialization has been already covered in the "Session Manager" section of Chapter 2 of Part 1. For all the initialization details, please refer to that chapter. When the master Smss creates the children Smss processes, it passes two section objects' handles as parameters. The two section objects represent the shared buffers used for exchanging data between multiple Smss and Csrss instances (one is used to communicate between the parent and the child Smss processes, and the other is used to communicate with the client subsystem process). The master Smss spawns the child using the *RtlCreateUserProcess* routine, specifying a flag to instruct the Process Manager to create a new session. In this case, the *PspAllocateProcess* kernel function calls the memory manager to create the new session address space.

The executable name that the child Smss launches at the end of its initialization is stored in the shared section, and, as stated in Chapter 2, is usually Wininit.exe for session 0 and Winlogon.exe for any interactive sessions. An important concept to remember is that before the new session 0 Smss launches Wininit, it connects to the Master Smss (through the SmApiPort ALPC port) and loads and initializes all the subsystems.

The session manager acquires the Load Driver privilege and asks the kernel to load and map the Win32k driver into the new Session address space (using the *NtSetSystemInformation* native API). It then launches the client-server subsystem process (Csrss.exe), specifying in the command line the following information: the root Windows Object directory name (\Windows), the shared section objects' handles, the subsystem name (Windows), and the subsystem's DLLs:

- **Basesrv.dll** The server side of the subsystem process
- **Sxssrv.dll** The side-by-side subsystem support extension module
- **Winsrv.dll** The multiuser subsystem support module

The client-server subsystem process performs some initialization: It enables some process mitigation options, removes unneeded privileges from its token, starts its own ETW provider, and initializes a linked list of *CSR_PROCESS* data structures to trace all the Win32 processes that will be started in the system. It then parses its command line, grabs the shared sections' handles, and creates two ALPC ports:

- **CSR API command port** (\Sessions\<<ID>\Windows\ApiPort) This ALPC Port will be used by every Win32 process to communicate with the Csrss subsystem. (Kernelbase.dll connects to it in its initialization routine.)

- **Subsystem Session Manager API Port** (\Sessions\

Csrss creates the two threads used to dispatch the commands received by the ALPC ports. Finally, it connects to the Session Manager, through another ALPC port (\SmApiPort), which was previously created in the Smss initialization process (step 6 of the initialization procedure described in Chapter 2). In the connection process, the Csrss process sends the name of the just-created Session Manager API port. From now on, new interactive sessions can be started. So, the main Csrss thread finally exits.

After spawning the subsystem process, the child Smss launches the initial process (Wininit or Winlogon) and then exits. Only the master instance of Smss remains active. The main thread in Smss waits forever on the process handle of Csrss, whereas the other ALPC threads wait for messages to create new sessions or subsystems. If either Wininit or Csrss terminate unexpectedly, the kernel crashes the system because these processes are marked as *critical*. If Winlogon terminates unexpectedly, the session associated with it is logged off.

Pending file rename operations

The fact that executable images and DLLs are memory-mapped when they're used makes it impossible to update core system files after Windows has finished booting (unless hotpatching technology is used, but that's only for Microsoft patches to the operating system). The *MoveFileEx* Windows API has an option to specify that a file move be delayed until the next boot. Service packs and hotfixes that must update in-use memory-mapped files install replacement files onto a system in temporary locations and use the *MoveFileEx* API to have them replace otherwise in-use files. When used with that option, *MoveFileEx* simply records commands in the *PendingFileRenameOperations* and *PendingFileRenameOperations2* keys under KLM\SYSTEM\CurrentControlSet\Control\Session Manager. These registry values are of type *MULTI_SZ*, where each operation is specified in pairs of file names: The first file name is the source location, and the second is the target location. Delete operations use an empty string as their target path. You can use the *Pendmoves* utility from Windows Sysinternals (<https://docs.microsoft.com/en-us/sysinternals/>) to view registered delayed rename and delete commands.

Wininit performs its startup steps, as described in the “Windows initialization process” section of Chapter 2 in Part 1, such as creating the initial window station and desktop objects. It also sets up the user environment, starts the Shutdown RPC server and WSI interface (see the “Shutdown” section later in this chapter for further details), and creates the service control manager (SCM) process (*Services.exe*), which loads all services and device drivers marked for auto-start. The local session manager (*Lsm.dll*) service, which runs in a shared *Svchost* process, is launched at this time. Wininit next checks whether there has been a previous system crash, and, if so, it carves the crash dump and starts the Windows Error Reporting process (*werfault.exe*) for further processing. It finally starts the Local Security Authentication Subsystem Service (%SystemRoot%\System32\lsass.exe) and, if Credential Guard is enabled, the Isolated LSA Trustlet (*Lsaiso.exe*) and waits forever for a system shutdown request.

On session 1 and beyond, Winlogon runs instead. While Wininit creates the noninteractive session 0 windows station, Winlogon creates the default interactive-session Windows station, called WinSta0, and two desktops: the Winlogon secure desktop and the default user desktop. Winlogon then queries the system boot information using the *NtQuerySystemInformation* API (only on the first interactive logon session). If the boot configuration includes the volatile Os Selection menu flag, it starts the GDI system (spawning a UMDF host process, fontdrvhost.exe) and launches the modern boot menu application (Bootim.exe). The volatile Os Selection menu flag is set in early boot stages by the Bootmgr only if a multiboot environment was previously detected (for more details see the section “The boot menu” earlier in this chapter).

Bootim is the GUI application that draws the modern boot menu. The new modern boot uses the Win32 subsystem (graphics driver and GDI+ calls) with the goal of supporting high resolutions for displaying boot choices and advanced options. Even touchscreens are supported, so the user can select which operating system to launch using a simple touch. Winlogon spawns the new Bootim process and waits for its termination. When the user makes a selection, Bootim exits. Winlogon checks the exit code; thus it’s able to detect whether the user has selected an OS or a boot tool or has simply requested a system shutdown. If the user has selected an OS different from the current one, Bootim adds the *bootsequence* one-shot BCD option in the main system boot store (see the section “The Windows Boot Manager” earlier in this chapter for more details about the BCD store). The new boot sequence is recognized (and the BCD option deleted) by the Windows Boot Manager after Winlogon has restarted the machine using *NtShutdownSystem* API. Winlogon marks the previous boot entry as good before restarting the system.

EXPERIMENT: Playing with the modern boot menu

The modern boot menu application, spawned by Winlogon after *Csrss* is started, is really a classical Win32 GUI application. This experiment demonstrates it. In this case, it’s better if you start with a properly configured multiboot system; otherwise, you won’t be able to see the multiple entries in the Modern boot menu.

Open a non-elevated console window (by typing **cmd** in the Start menu search box) and go to the `\Windows\System32` path of the boot volume by typing **cd /d C:\Windows\System32** (where C is the letter of your boot volume). Then type **Bootim.exe** and press **Enter**. A screen similar to the modern boot menu should appear, showing only the Turn Off Your Computer option. This is because the Bootim process has been started under the standard non-administrative token (the one generated for User Account Control). Indeed, the process isn’t able to access the system boot configuration data. Press **Ctrl+Alt+Del** to start the Task Manager and terminate the *Bootim* process, or simply select **Turn Off Your Computer**. The actual shutdown process is started by the caller process (which is Winlogon in the original boot sequence) and not by *Bootim*.

Now you should run the Command Prompt window with an administrative token by right-clicking its taskbar icon or the **Command Prompt** item in the Windows search box and selecting **Run As Administrator**. In the new administrative prompt, start the Bootlm executable. This time you will see the real modern boot menu, compiled with all the boot options and tools, similar to the one shown in the following picture:

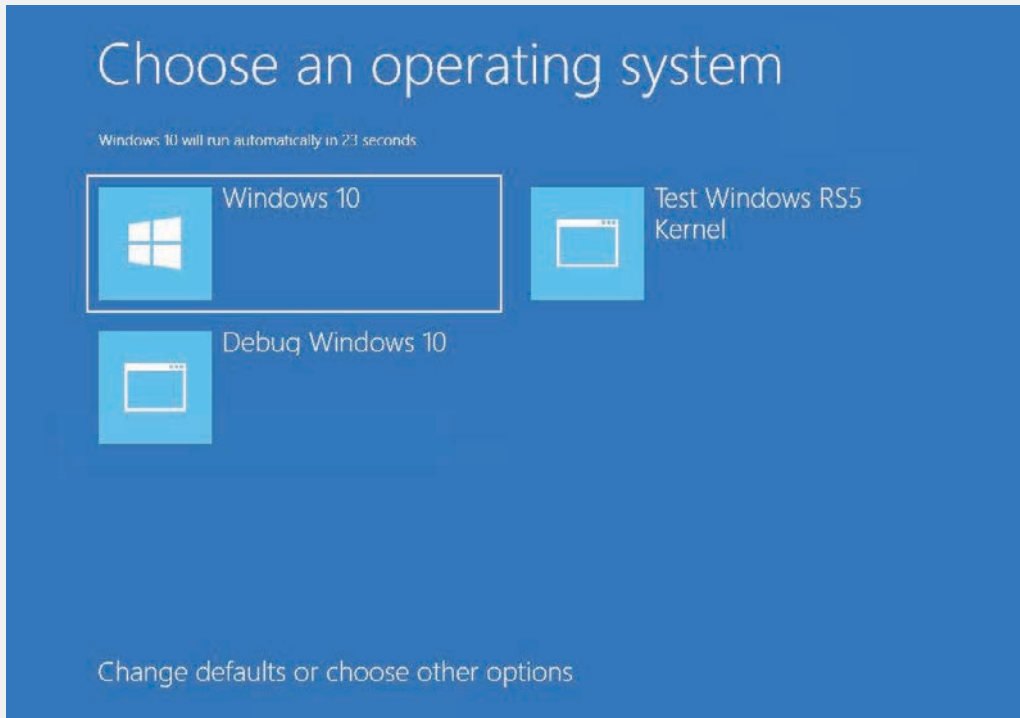

In all other cases, Winlogon waits for the initialization of the LSASS process and LSM service. It then spawns a new instance of the DWM process (Desktop Windows Manager, a component used to draw the modern graphical interface) and loads the registered credential providers for the system (by default, the Microsoft credential provider supports password-based, pin-based, and biometrics-based logons) into a child process called LogonUI (`%SystemRoot%\System32\Logonui.exe`), which is responsible for displaying the logon interface. (For more details on the startup sequence for Wininit, Winlogon, and LSASS, see the section “Winlogon initialization” in Chapter 7 in Part 1.)

After launching the LogonUI process, Winlogon starts its internal finite-state machine. This is used to manage all the possible states generated by the different logon types, like the standard interactive logon, terminal server, fast user switch, and hiberboot. In standard interactive logon types, Winlogon shows a welcome screen and waits for an interactive logon notification from the credential provider (configuring the SAS sequence if needed). When the user has inserted their credential (that can be a password, PIN, or biometric information), Winlogon creates a logon session LUID, and validates the logon using the authentication packages registered in Lsass (a process for which you can find more

information in the section “User logon steps” in Chapter 7 in Part 1). Even if the authentication won’t succeed, Winlogon at this stage marks the current boot as good. If the authentication succeeded, Winlogon verifies the “sequential logon” scenario in case of client SKUs, in which only one session each time could be generated, and, if this is not the case and another session is active, asks the user how to proceed. It then loads the registry hive from the profile of the user logging on, mapping it to HKCU. It adds the required ACLs to the new session’s Windows Station and Desktop and creates the user’s environment variables that are stored in HKCU\Environment.

Winlogon next waits the Sihost process and starts the shell by launching the executable or executables specified in HKLM\SOFTWARE\Microsoft\Windows NT\CurrentVersion\WinLogon\Userinit (with multiple executables separated by commas) that by default points at \Windows\System32\Userinit.exe. The new Userinit process will live in Winsta0\Default desktop. Userinit.exe performs the following steps:

1. Creates the per-session volatile Explorer Session key HKCU\Software\Microsoft\Windows\CurrentVersion\Explorer\SessionInfo\.
2. Processes the user scripts specified in HKCU\Software\Policies\Microsoft\Windows\System\Scripts and the machine logon scripts in HKLM\SOFTWARE\Policies\Microsoft\Windows\System\Scripts. (Because machine scripts run after user scripts, they can override user settings.)
3. Launches the comma-separated shell or shells specified in HKCU\Software\Microsoft\Windows NT\CurrentVersion\Winlogon\Shell. If that value doesn’t exist, Userinit.exe launches the shell or shells specified in HKLM\SOFTWARE\Microsoft\Windows NT\CurrentVersion\Winlogon\Shell, which is by default Explorer.exe.
4. If Group Policy specifies a user profile quota, starts %SystemRoot%\System32\Proquota.exe to enforce the quota for the current user.

Winlogon then notifies registered network providers that a user has logged on, starting the mpsnotify.exe process. The Microsoft network provider, Multiple Provider Router (%SystemRoot%\System32\Mpr.dll), restores the user’s persistent drive letter and printer mappings stored in HKCU\Network and HKCU\Printers, respectively. Figure 12-11 shows the process tree as seen in Process Monitor after a logon (using its boot logging capability). Note the Ssmss processes that are dimmed (meaning that they have since exited). These refer to the spawned copies that initialize each session.

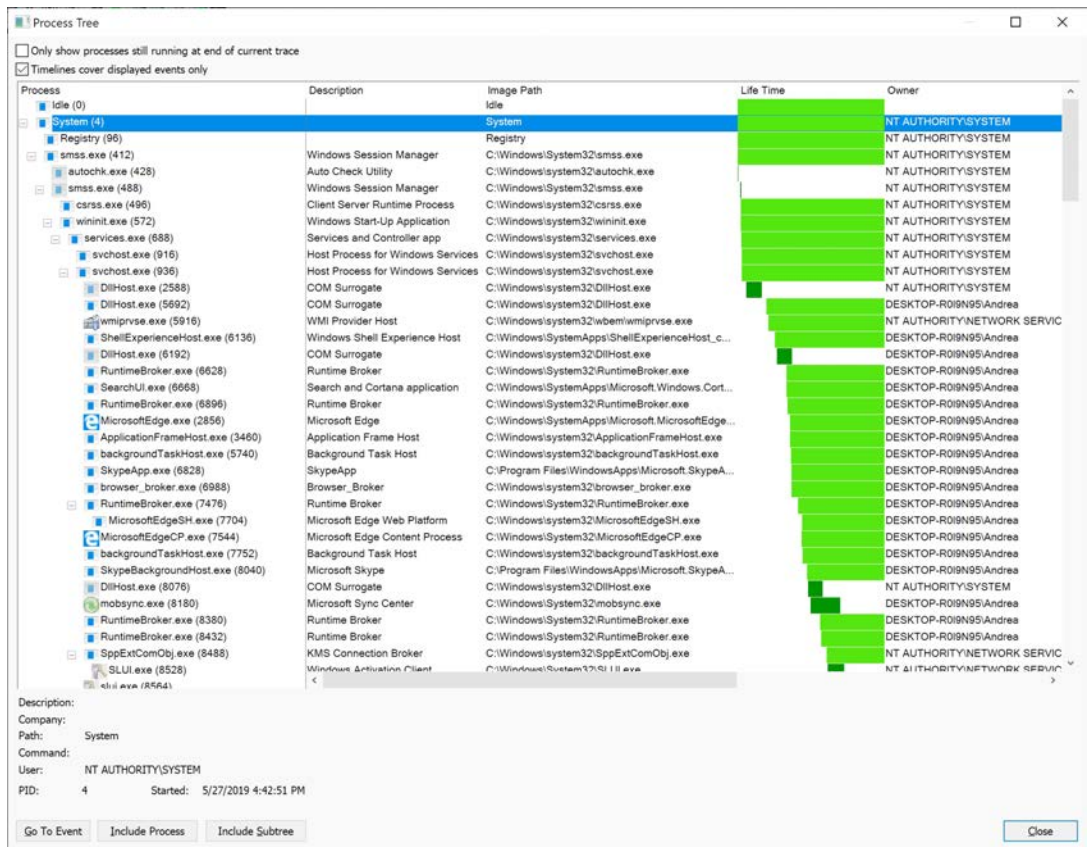

FIGURE 12-11 Process tree during logon.

ReadyBoot

Windows uses the standard logical boot-time prefetcher (described in Chapter 5 of Part 1) if the system has less than 400 MB of free memory, but if the system has 400 MB or more of free RAM, it uses an in-RAM cache to optimize the boot process. The size of the cache depends on the total RAM available, but it's large enough to create a reasonable cache and yet allow the system the memory it needs to boot smoothly. ReadyBoot is implemented in two distinct binaries: the ReadyBoost driver (Rdyboost.sys) and the Sysmain service (Sysmain.dll, which also implements SuperFetch).

The cache is implemented by the Store Manager in the same device driver that implements ReadyBoost caching (Rdyboost.sys), but the cache's population is guided by the boot plan previously stored in the registry. Although the boot cache could be compressed like the ReadyBoost cache, another difference between ReadyBoost and ReadyBoot cache management is that while in ReadyBoot mode, the cache is not encrypted. The ReadyBoost service deletes the cache 50 seconds after the service starts, or if other memory demands warrant it.

When the system boots, at phase 1 of the NT kernel initialization, the ReadyBoost driver, which is a volume filter driver, intercepts the boot volume creation and decides whether to enable the cache. The cache is enabled only if the target volume is registered in the HKLM\System\CurrentControlSet\Services\rdyboost\Parameters\ReadyBootVolumeUniqueld registry value. This value contains the ID of the boot volume. If ReadyBoot is enabled, the ReadyBoost driver starts to log all the volume boot I/Os (through ETW), and, if a previous boot plan is registered in the BootPlan registry binary value, it spawns a system thread that will populate the entire cache using asynchronous volume reads. When a new Windows OS is installed, at the first system boot these two registry values do not exist, so neither the cache nor the log trace are enabled.

In this situation the Sysmain service, which is started later in the boot process by the SCM, determines whether the cache needs to be enabled, checking the system configuration and the running Windows SKU. There are situations in which ReadyBoot is completely disabled, such as when the boot disk is a solid state drive. If the check yields a positive result, Sysmain enables ReadyBoot by writing the boot volume ID on the relative registry value (*ReadyBootVolumeUniqueld*) and by enabling the WMI ReadyBoot Autologger in the HKLM\SYSTEM\CurrentControlSet\Control\WMI\AutoLogger\Readyboot registry key. At the next system boot, the ReadyBoost driver logs all the Volume I/Os but without populating the cache (still no boot plan exists).

After every successive boot, the Sysmain service uses idle CPU time to calculate a boot-time caching plan for the next boot. It analyzes the recorded ETW I/O events and identifies which files were accessed and where they're located on disk. It then stores the processed traces in %SystemRoot%\Prefetch\Readyboot as .fx files and calculates the new caching boot plan using the trace files of the five previous boots. The Sysmain service stores the new generated plan under the registry value, as shown in Figure 12-12. The ReadyBoost boot driver reads the boot plan and populates the cache, minimizing the overall boot startup time.

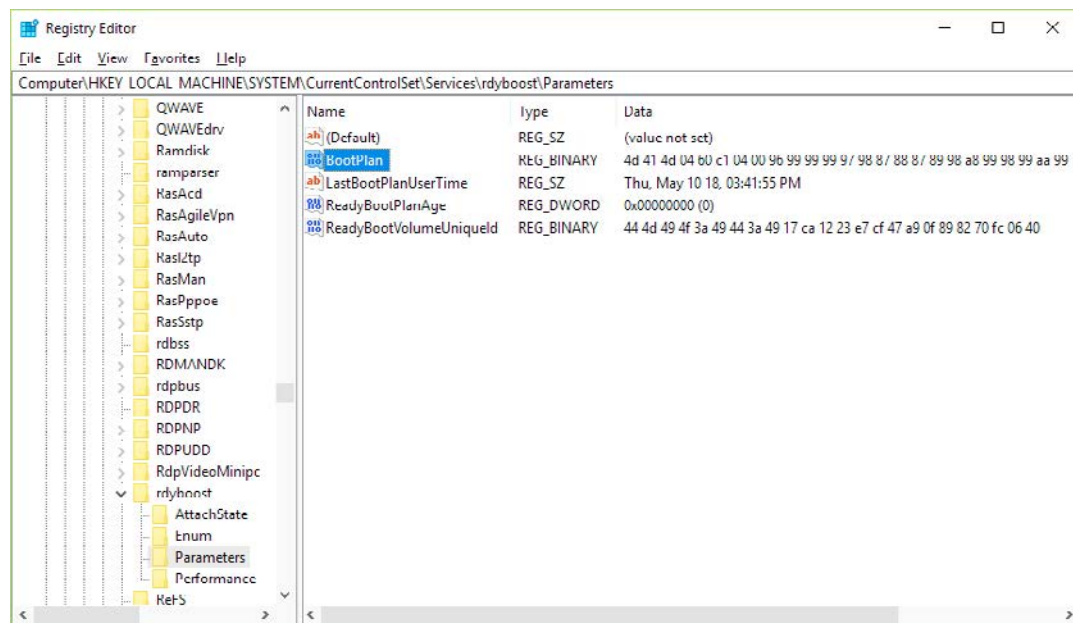

FIGURE 12-12 ReadyBoot configuration and statistics.

Images that start automatically

In addition to the Userinit and Shell registry values in Winlogon's key, there are many other registry locations and directories that default system components check and process for automatic process start-up during the boot and logon processes. The Msconfig utility (%SystemRoot%\System32\Msconfig.exe) displays the images configured by several of the locations. The Autoruns tool, which you can download from Sysinternals and is shown in Figure 12-13, examines more locations than Msconfig and displays more information about the images configured to automatically run. By default, Autoruns shows only the locations that are configured to automatically execute at least one image, but selecting the **Include Empty Locations** entry on the **Options** menu causes Autoruns to show all the locations it inspects. The **Options** menu also has selections to direct Autoruns to hide Microsoft entries, but you should always combine this option with **Verify Image Signatures**; otherwise, you risk hiding malicious programs that include false information about their company name information.

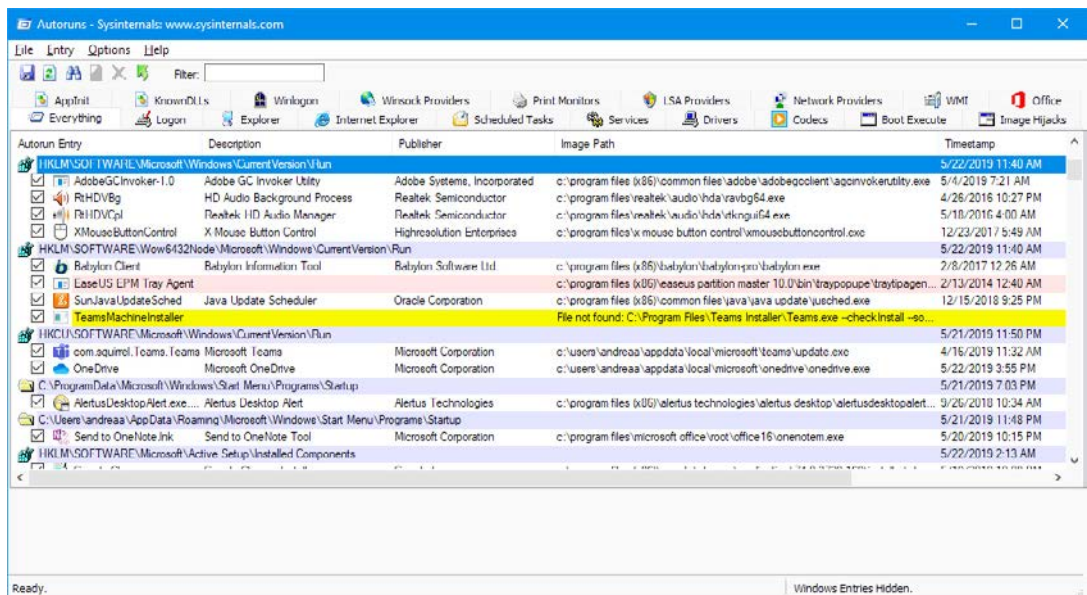

FIGURE 12-13 The Autoruns tool available from Sysinternals.

Shutdown

The system shutdown process involves different components. Wininit, after having performed all its initialization, waits for a system shutdown.

If someone is logged on and a process initiates a shutdown by calling the Windows *ExitWindowsEx* function, a message is sent to that session's Csrss instructing it to perform the shutdown. Csrss in turn impersonates the caller and sends an RPC message to Winlogon, telling it to perform a system shutdown. Winlogon checks whether the system is in the middle of a hybrid boot transition (for further details about hybrid boot, see the "Hybernation and Fast Startup" section later in this chapter), then impersonates the currently logged-on user (who might or might not have the same security context as

the user who initiated the system shutdown), asks LogonUI to fade out the screen (configurable through the registry value HKLM\Software\Microsoft\Windows NCurrentVersion\Winlogon\FadePeriodConfiguration), and calls *ExitWindowsEx* with special internal flags. Again, this call causes a message to be sent to the Csrss process inside that session, requesting a system shutdown.

This time, Csrss sees that the request is from Winlogon and loops through all the processes in the logon session of the interactive user (again, not the user who requested a shutdown) in reverse order of their *shutdown level*. A process can specify a shutdown level, which indicates to the system when it wants to exit with respect to other processes, by calling *SetProcessShutdownParameters*. Valid shutdown levels are in the range 0 through 1023, and the default level is 640. Explorer, for example, sets its shutdown level to 2, and Task Manager specifies 1. For each active process that owns a top-level window, Csrss sends the *WM_QUERYENDSESSION* message to each thread in the process that has a Windows message loop. If the thread returns TRUE, the system shutdown can proceed. Csrss then sends the *WM_ENDSESSION* Windows message to the thread to request it to exit. Csrss waits the number of seconds defined in HKCU\Control Panel\Desktop\HungAppTimeout for the thread to exit. (The default is 5000 milliseconds.)

If the thread doesn't exit before the timeout, Csrss fades out the screen and displays the hung-program screen shown in Figure 12-14. (You can disable this screen by creating the registry value HKCU\Control Panel\Desktop\AutoEndTasks and setting it to 1.) This screen indicates which programs are currently running and, if available, their current state. Windows indicates which program isn't shutting down in a timely manner and gives the user a choice of either killing the process or aborting the shutdown. (There is no timeout on this screen, which means that a shutdown request could wait forever at this point.) Additionally, third-party applications can add their own specific information regarding state—for example, a virtualization product could display the number of actively running virtual machines (using the *ShutdownBlockReasonCreate* API).

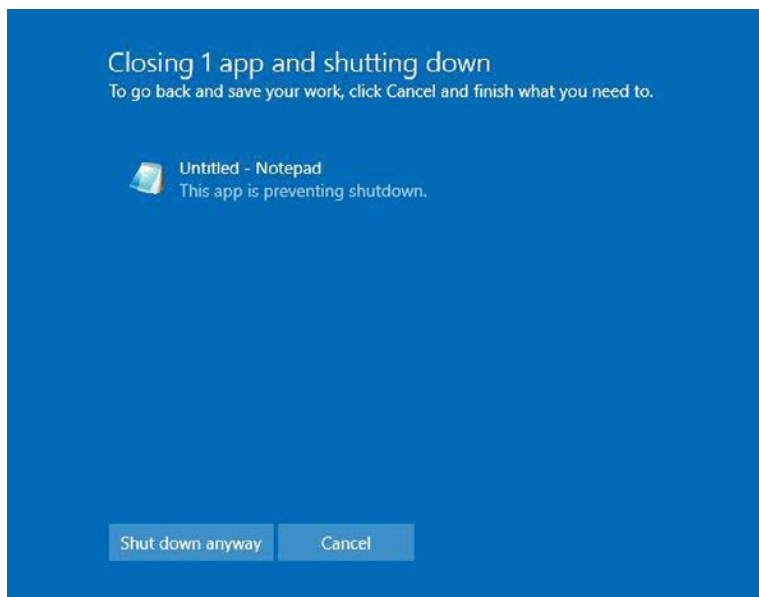
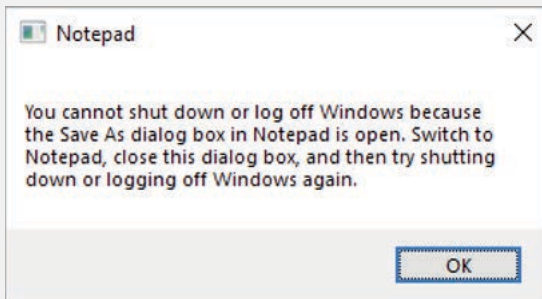

FIGURE 12-14 Hung-program screen.

EXPERIMENT: Witnessing the HungAppTimeout

You can see the use of the HungAppTimeout registry value by running Notepad, entering text into its editor, and then logging off. After the amount of time specified by the HungAppTimeout registry value has expired, Csrss.exe presents a prompt that asks you whether you want to end the Notepad process, which has not exited because it's waiting for you to tell it whether to save the entered text to a file. If you select Cancel, Csrss.exe aborts the shutdown.

As a second experiment, if you try shutting down again (with Notepad's query dialog box still open), Notepad displays its own message box to inform you that shutdown cannot cleanly proceed. However, this dialog box is merely an informational message to help users—Csrss.exe will still consider that Notepad is "hung" and display the user interface to terminate unresponsive processes.



If the thread does exit before the timeout, Csrss continues sending the *WM_QUERYENDSESSION/WM_ENDSESSION* message pairs to the other threads in the process that own windows. Once all the threads that own windows in the process have exited, Csrss terminates the process and goes on to the next process in the interactive session.

If Csrss finds a console application, it invokes the console control handler by sending the *CTRL_LOGOFF_EVENT* event. (Only service processes receive the *CTRL_SHUTDOWN_EVENT* event on shutdown.) If the handler returns *FALSE*, Csrss kills the process. If the handler returns *TRUE* or doesn't respond by the number of seconds defined by *HKCU\Control Panel\Desktop\WaitToKillTimeout* (the default is 5,000 milliseconds), Csrss displays the hung-program screen shown in Figure 12-14.

Next, the Winlogon state machine calls *ExitWindowsEx* to have Csrss terminate any COM processes that are part of the interactive user's session.

At this point, all the processes in the interactive user's session have been terminated. Wininit next calls *ExitWindowsEx*, which this time executes within the system process context. This causes Wininit to send a message to the Csrss part of session 0, where the services live. Csrss then looks at all the processes belonging to the system context and performs and sends the *WM_QUERYENDSESSION/WM_ENDSESSION* messages to GUI threads (as before). Instead of sending *CTRL_LOGOFF_EVENT*, however, it sends *CTRL_SHUTDOWN_EVENT* to console applications that have registered control handlers. Note that the SCM is a console program that registers a control handler. When it receives the shutdown request, it in turn sends the service shutdown control message to all services that registered

for shutdown notification. For more details on service shutdown (such as the shutdown timeout Csrss uses for the SCM), see the “Services” section in Chapter 10.

Although Csrss performs the same timeouts as when it was terminating the user processes, it doesn’t display any dialog boxes and doesn’t kill any processes. (The registry values for the system process timeouts are taken from the default user profile.) These timeouts simply allow system processes a chance to clean up and exit before the system shuts down. Therefore, many system processes are in fact still running when the system shuts down, such as Smss, Wininit, Services, and LSASS.

Once Csrss has finished its pass notifying system processes that the system is shutting down, Wininit wakes up, waits 60 seconds for all sessions to be destroyed, and then, if needed, invokes System Restore (at this stage no user process is active in the system, so the restore application can process all the needed files that may have been in use before). Wininit finishes the shutdown process by shutting down LogonUi and calling the executive subsystem function *NtShutdownSystem*. This function calls the function *PoSetSystemPowerState* to orchestrate the shutdown of drivers and the rest of the executive subsystems (Plug and Play manager, power manager, executive, I/O manager, configuration manager, and memory manager).

For example, *PoSetSystemPowerState* calls the I/O manager to send shutdown I/O packets to all device drivers that have requested shutdown notification. This action gives device drivers a chance to perform any special processing their device might require before Windows exits. The stacks of worker threads are swapped in, the configuration manager flushes any modified registry data to disk, and the memory manager writes all modified pages containing file data back to their respective files. If the option to clear the paging file at shutdown is enabled, the memory manager clears the paging file at this time. The I/O manager is called a second time to inform the file system drivers that the system is shutting down. System shutdown ends in the power manager. The action the power manager takes depends on whether the user specified a shutdown, a reboot, or a power down.

Modern apps all rely on the Windows Shutdown Interface (WSI) to properly shut down the system. The WSI API still uses RPC to communicate between processes and supports the grace period. The grace period is a mechanism by which the user is informed of an incoming shutdown, before the shutdown actually begins. This mechanism is used even in case the system needs to install updates. Advapi32 uses WSI to communicate with Wininit. Wininit queues a timer, which fires at the end of the grace period and calls Winlogon to initialize the shutdown request. Winlogon calls *ExitWindowsEx*, and the rest of the procedure is identical to the previous one. All the UWP applications (and even the new Start menu) use the ShutdownUX module to switch off the system. ShutdownUX manages the power transitions for UWP applications and is linked against Advapi32.dll.

Hibernation and Fast Startup

To improve the system startup time, Windows 8 introduced a new feature called Fast Startup (also known as hybrid boot). In previous Windows editions, if the hardware supported the S4 system power-state (see Chapter 6 of Part 1 for further details about the power manager), Windows allowed the user to put the system in Hibernation mode. To properly understand Fast Startup, a complete description of the Hibernation process is needed.

When a user or an application calls *SetSuspendState* API, a worker item is sent to the power manager. The worker item contains all the information needed by the kernel to initialize the power state transition. The power manager informs the prefetcher of the outstanding hibernation request and waits for all its pending I/Os to complete. It then calls the *NtSetSystemPowerState* kernel API.

NtSetSystemPowerState is the key function that orchestrates the entire hibernation process. The routine checks that the caller token includes the Shutdown privilege, synchronizes with the Plug and Play manager, Registry, and power manager (in this way there is no risk that any other transactions could interfere in the meantime), and cycles against all the loaded drivers, sending an *IRP_MN_QUERY_POWER* Irp to each of them. In this way the power manager informs each driver that a power operation is started, so the driver's devices must not start any more I/O operations or take any other action that would prevent the successful completion of the hibernation process. If one of the requests fails (perhaps a driver is in the middle of an important I/O), the procedure is aborted.

The power manager uses an internal routine that modifies the system boot configuration data (BCD) to enable the Windows Resume boot application, which, as the name implies, attempts to resume the system after the hibernation. (For further details, see the section "The Windows Boot Manager" earlier in this chapter). The power manager:

- Opens the BCD object used to boot the system and reads the associated Windows Resume application GUID (stored in a special unnamed BCD element that has the value 0x23000003).
- Searches the Resume object in the BCD store, opens it, and checks its description. Writes the device and path BCD elements, linking them to the `\Windows\System32\winresume.efi` file located in the boot disk, and propagates the boot settings from the main system BCD object (like the boot debugger options). Finally, it adds the hibernation file path and device descriptor into *filepath* and *filedevice* BCD elements.
- Updates the root Boot Manager BCD object: writes the *resumeobject* BCD element with the GUID of the discovered Windows Resume boot application, sets the *resume* element to 1, and, in case the hibernation is used for Fast Startup, sets the *hiberboot* element to 1.

Next, the power manager flushes the BCD data to disk, calculates all the physical memory ranges that need to be written into the hibernation file (a complex operation not described here), and sends a new power IRP to each driver (*IRP_MN_SET_POWER* function). This time the drivers must put their device to sleep and don't have the chance to fail the request and stop the hibernation process. The system is now ready to hibernate, so the power manager starts a "sleeper" thread that has the sole purpose of powering the machine down. It then waits for an event that will be signaled only when the resume is completed (and the system is restarted by the user).

The sleeper thread halts all the CPUs (through DPC routines) except its own, captures the system time, disables interrupts, and saves the CPU state. It finally invokes the power state handler routine (implemented in the HAL), which executes the ACPI machine code needed to put the entire system to sleep and calls the routine that actually writes all the physical memory pages to disk. The sleeper thread uses the crash dump storage driver to emit the needed low-level disk I/Os for writing the data in the hibernation file.

The Windows Boot Manager, in its earlier boot stages, recognizes the resume BCD element (stored in the Boot Manager BCD descriptor), opens the Windows Resume boot application BCD object, and reads the saved hibernation data. Finally, it transfers the execution to the Windows Resume boot application (Winresume.efi). *HbMain*, the entry point routine of Winresume, reinitializes the boot library and performs different checks on the hibernation file:

- Verifies that the file has been written by the same executing processor architecture
- Checks whether a valid page file exists and has the correct size
- Checks whether the firmware has reported some hardware configuration changes (through the FADT and FACS ACPI tables)
- Checks the hibernation file integrity

If one of these checks fails, Winresume ends the execution and returns control to the Boot Manager, which discards the hibernation file and restarts a standard cold boot. On the other hand, if all the previous checks pass, Winresume reads the hibernation file (using the UEFI boot library) and restores all the saved physical pages contents. Next, it rebuilds the needed page tables and memory data structures, copies the needed information to the OS context, and finally transfers the execution to the Windows kernel, restoring the original CPU context. The Windows kernel code restarts from the same power manager sleeper thread that originally hibernated the system. The power manager reenables interrupts and thaws all the other system CPUs. It then updates the system time, reading it from the CMOS, rebases all the system timers (and watchdogs), and sends another *IRP_MN_SET_POWER* Irp to each system driver, asking them to restart their devices. It finally restarts the prefetcher and sends it the boot loader log for further processing. The system is now fully functional; the system power state is S0 (fully on).

Fast Startup is a technology that's implemented using hibernation. When an application passes the *EWX_HYBRID_SHUTDOWN* flag to the *ExitWindowsEx* API or when a user clicks the Shutdown start menu button, if the system supports the S4 (hibernation) power state and has a hibernation file enabled, it starts a hybrid shutdown. After *Csrss* has switched off all the interactive session processes, session 0 services, and COM servers (see the "Shutdown" section for all the details about the actual shutdown process), Winlogon detects that the shutdown request has the *Hybrid* flag set, and, instead of waking up the shutdown code of Winint, it goes into a different route. The new Winlogon state uses the *NtPowerInformation* system API to switch off the monitor; it next informs LogonUI about the outstanding hybrid shutdown, and finally calls the *NtInitializePowerAction* API, asking for a system hibernation. The procedure from now on is the same as the system hibernation.

EXPERIMENT: Understanding hybrid shutdown

You can see the effects of a hybrid shutdown by manually mounting the BCD store after the system has been switched off, using an external OS. First, make sure that your system has Fast Startup enabled. To do this, type **Control Panel** in the Start menu search box, select **System and Security**, and then select **Power Options**. After clicking **Choose What The Power Button does**, located in the upper-left side of the Power Options window, the following screen should appear:

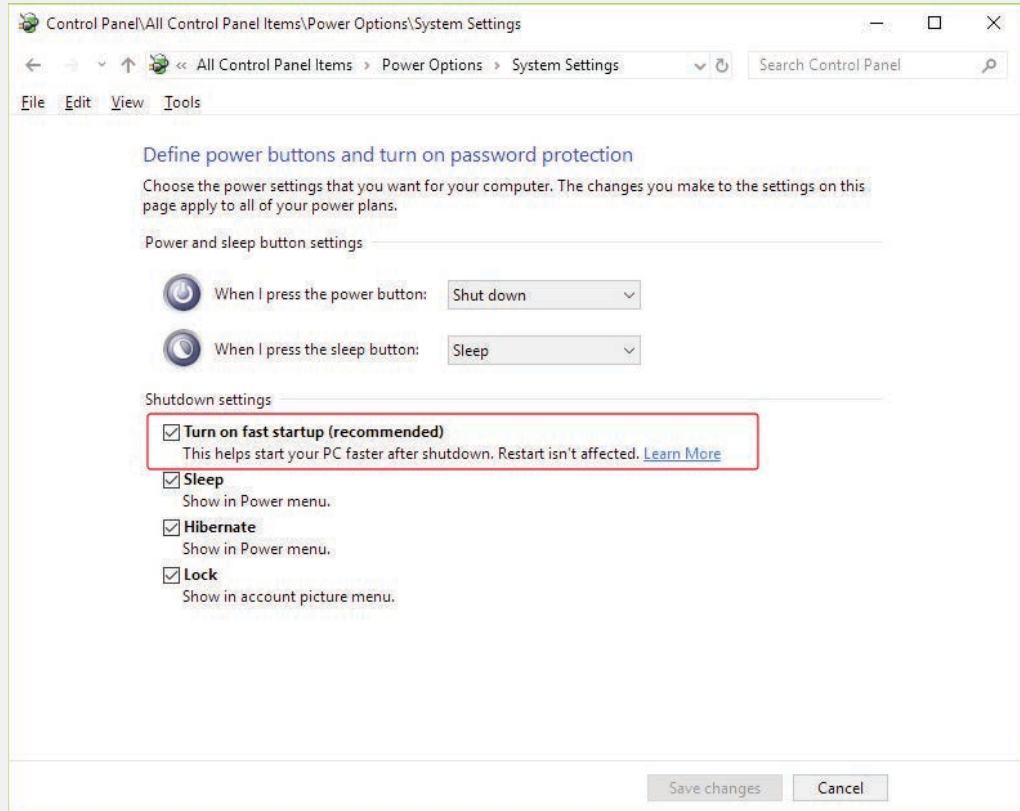

As shown in the figure, make sure that the **Turn On Fast Startup** option is selected. Otherwise, your system will perform a standard shutdown. You can shut down your workstation using the power button located in the left side of the Start menu. Before the computer shuts down, you should insert a DVD or USB flash drive that contains the external OS (a copy of a live Linux should work well). For this experiment, you can't use the Windows Setup Program (or any WinRE based environments) because the setup procedure clears all the hibernation data before mounting the system volume.

When you switch on the workstation, perform the boot from an external DVD or USB drive. This procedure varies between different PC manufacturers and usually requires accessing the BIOS interface. For instructions on accessing the BIOS and performing the boot from an external drive, check your workstation's user manual. (For example, in the Surface Pro and Surface Book laptops, usually it's sufficient to press and hold the Volume Up button before pushing and releasing the Power button for entering the BIOS configuration.) When the new OS is ready, mount the main UEFI system partition with a partitioning tool (depending on the OS type). We don't describe this procedure. After the system partition has been correctly mounted, copy the system Boot Configuration Data file, located in `\EFI\Microsoft\Boot\BCD`, to an external drive (or in the same USB flash drive used for booting). Then you can restart your PC and wait for Windows to resume from hibernation.

After your PC restarts, run the Registry Editor and open the root `HKEY_LOCAL_MACHINE` registry key. Then from the **File** menu, select **Load Hive**. Browse for your saved BCD file, select **Open**, and assign the BCD key name for the new loaded hive. Now you should identify the main Boot Manager BCD object. In all Windows systems, this root BCD object has the `{9DEA862C-5CDD-4E70-ACC1-F32B344D4795}` GUID. Open the relative key and its *Elements* subkey. If the system has been correctly switched off with a hybrid shutdown, you should see the *resume* and *hiberboot* BCD elements (the corresponding keys names are 26000005 and 26000025; see Table 12-2 for further details) with their *Element* registry value set to 1.

To properly locate the BCD element that corresponds to your Windows Installation, use the *displayorder* element (key named 24000001), which lists all the installed OS boot entries. In the *Element* registry value, there is a list of all the GUIDs of the BCD objects that describe the installed operating systems loaders. Check the BCD object that describes the Windows Resume application, reading the GUID value of the *resumeobject* BCD element (which corresponds to the 23000006 key). The BCD object with this GUID includes the hibernation file path into the filepath element, which corresponds to the key named 22000002.

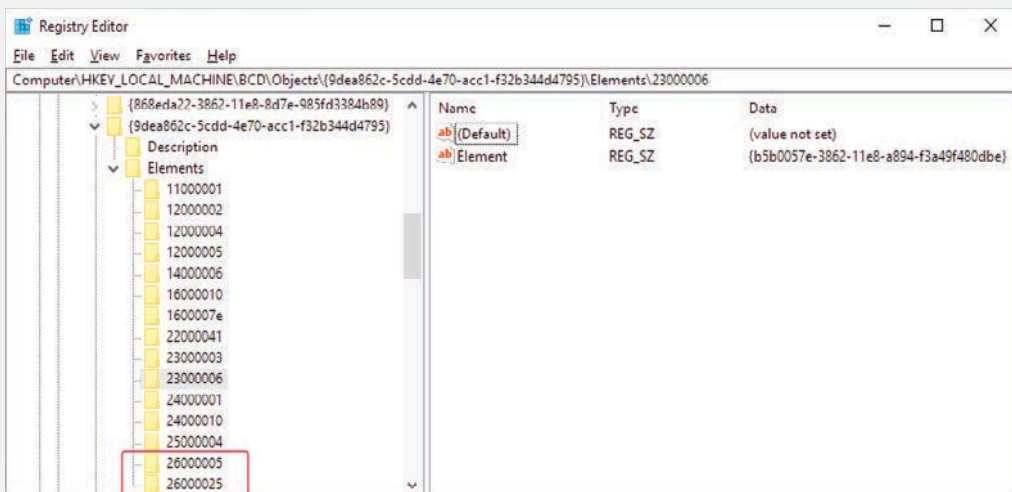

Windows Recovery Environment (WinRE)

The Windows Recovery Environment provides an assortment of tools and automated repair technologies to fix the most common startup problems. It includes six main tools:

- **System Restore** Allows restoring to a previous restore point in cases in which you can't boot the Windows installation to do so, even in safe mode.
- **System Image Recover** Called Complete PC Restore or Automated System Recovery (ASR) in previous versions of Windows, this restores a Windows installation from a complete backup, not just from a system restore point, which might not contain all damaged files and lost data.
- **Startup Repair** An automated tool that detects the most common Windows startup problems and automatically attempts to repair them.
- **PC Reset** A tool that removes all the applications and drivers that don't belong to the standard Windows installation, restores all the settings to their default, and brings back Windows to its original state after the installation. The user can choose to maintain all personal data files or remove everything. In the latter case, Windows will be automatically reinstalled from scratch.
- **Command Prompt** For cases where troubleshooting or repair requires manual intervention (such as copying files from another drive or manipulating the BCD), you can use the command prompt to have a full Windows shell that can launch almost any Windows program (as long as the required dependencies can be satisfied)—unlike the Recovery Console on earlier versions of Windows, which only supported a limited set of specialized commands.
- **Windows Memory Diagnostic Tool** Performs memory diagnostic tests that check for signs of faulty RAM. Faulty RAM can be the reason for random kernel and application crashes and erratic system behavior.

When you boot a system from the Windows DVD or boot disks, Windows Setup gives you the choice of installing Windows or repairing an existing installation. If you choose to repair an installation, the system displays a screen similar to the modern boot menu (shown in Figure 12-15), which provides different choices.

The user can select to boot from another device, use a different OS (if correctly registered in the system BCD store), or choose a recovery tool. All the described recovery tools (except for the Memory Diagnostic Tool) are located in the Troubleshoot section.

The Windows setup application also installs WinRE to a recovery partition on a clean system installation. You can access WinRE by keeping the Shift key pressed when rebooting the computer through the relative shutdown button located in the Start menu. If the system uses the Legacy Boot menu, WinRE can be started using the F8 key to access advanced boot options during Bootmgr execution. If you see the Repair Your Computer option, your machine has a local hard disk copy. Additionally, if your system failed to boot as the result of damaged files or for any other reason that Winload can understand, it instructs Bootmgr to automatically start WinRE at the next reboot cycle. Instead of the dialog box shown in Figure 12-15, the recovery environment automatically launches the Startup Repair tool, shown in Figure 12-16.

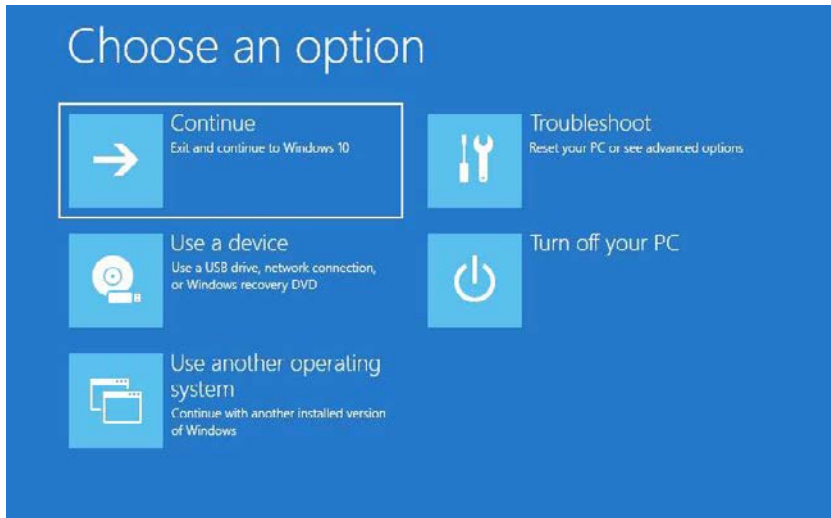

FIGURE 12-15 The Windows Recovery Environment startup screen.

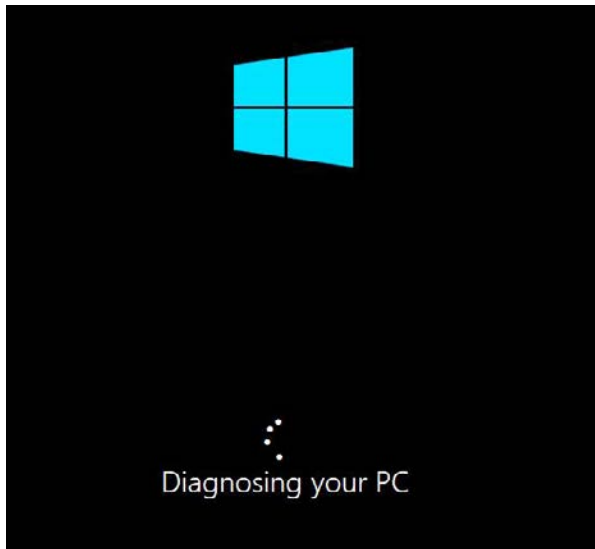

FIGURE 12-16 The Startup Recovery tool.

At the end of the scan and repair cycle, the tool automatically attempts to fix any damage found, including replacing system files from the installation media. If the Startup Repair tool cannot automatically fix the damage, you get a chance to try other methods, and the System Recovery Options dialog box is displayed again.

The Windows Memory Diagnostics Tool can be launched from a working system or from a Command Prompt opened in WinRE using the `mdsched.exe` executable. The tool asks the user if they want to reboot the computer to run the test. If the system uses the Legacy Boot menu, the Memory Diagnostics Tool can be executed using the Tab key to navigate to the Tools section.

Safe mode

Perhaps the most common reason Windows systems become unbootable is that a device driver crashes the machine during the boot sequence. Because software or hardware configurations can change over time, latent bugs can surface in drivers at any time. Windows offers a way for an administrator to attack the problem: booting in *safe mode*. Safe mode is a boot configuration that consists of the minimal set of device drivers and services. By relying on only the drivers and services that are necessary for booting, Windows avoids loading third-party and other nonessential drivers that might crash.

There are different ways to enter safe mode:

- Boot the system in WinRE and select **Startup Settings** in the Advanced options (see Figure 12-17).

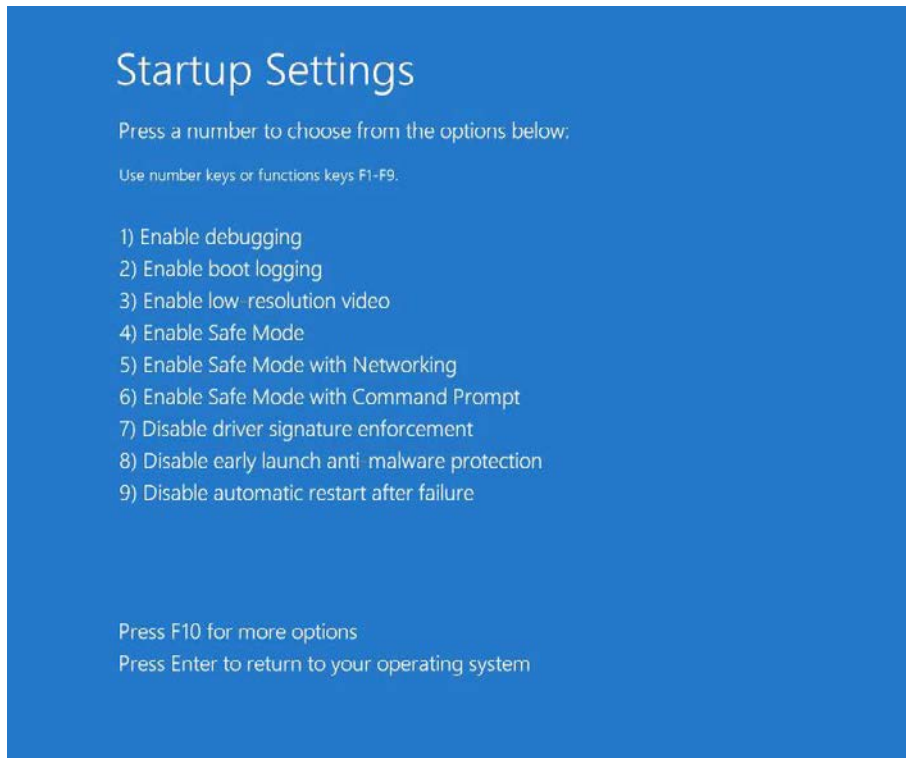

FIGURE 12-17 The Startup Settings screen, in which the user can select three different kinds of safe mode.

- In multi-boot environments, select **Change Defaults Or Choose Other Options** in the modern boot menu and go to the **Troubleshoot** section to select the **Startup Settings** button as in the previous case.
- If your system uses the Legacy Boot menu, press the **F8** key to enter the **Advanced Boot Options** menu.

You typically choose from three safe-mode variations: Safe mode, Safe mode with networking, and Safe mode with command prompt. Standard safe mode includes the minimum number of device drivers and services necessary to boot successfully. Networking-enabled safe mode adds network drivers and services to the drivers and services that standard safe mode includes. Finally, safe mode with command prompt is identical to standard safe mode except that Windows runs the Command Prompt application (Cmd.exe) instead of Windows Explorer as the shell when the system enables GUI mode.

Windows includes a fourth safe mode—Directory Services Restore mode—which is different from the standard and networking-enabled safe modes. You use Directory Services Restore mode to boot the system into a mode where the Active Directory service of a domain controller is offline and unopened. This allows you to perform repair operations on the database or restore it from backup media. All drivers and services, with the exception of the Active Directory service, load during a Directory Services Restore mode boot. In cases when you can't log on to a system because of Active Directory database corruption, this mode enables you to repair the corruption.

Driver loading in safe mode

How does Windows know which device drivers and services are part of standard and networking-enabled safe mode? The answer lies in the HKLM\SYSTEM\CurrentControlSet\Control\SafeBoot registry key. This key contains the Minimal and Network subkeys. Each subkey contains more subkeys that specify the names of device drivers or services or of groups of drivers. For example, the *BasicDisplay.sys* subkey identifies the Basic display device driver that the startup configuration includes. The Basic display driver provides basic graphics services for any PC-compatible display adapter. The system uses this driver as the safe-mode display driver in lieu of a driver that might take advantage of an adapter's advanced hardware features but that might also prevent the system from booting. Each subkey under the *SafeBoot* key has a default value that describes what the subkey identifies; the *BasicDisplay.sys* subkey's default value is Driver.

The *Boot* file system subkey has as its default value Driver Group. When developers design a device driver's installation script (.inf file), they can specify that the device driver belongs to a driver group. The driver groups that a system defines are listed in the List value of the HKLM\SYSTEM\CurrentControlSet\Control\ServiceGroupOrder key. A developer specifies a driver as a member of a group to indicate to Windows at what point during the boot process the driver should start. The *ServiceGroupOrder* key's primary purpose is to define the order in which driver groups load; some driver types must load either before or after other driver types. The *Group* value beneath a driver's configuration registry key associates the driver with a group.

Driver and service configuration keys reside beneath HKLM\SYSTEM\CurrentControlSet\Services. If you look under this key, you'll find the *BasicDisplay* key for the basic display device driver, which you can see in the registry is a member of the Video group. Any file system drivers that Windows requires for access to the Windows system drive are automatically loaded as if part of the Boot file system group. Other file system drivers are part of the File System group, which the standard and networking-enabled safe-mode configurations also include.

When you boot into a safe-mode configuration, the boot loader (Winload) passes an associated switch to the kernel (Ntoskrnl.exe) as a command-line parameter, along with any switches you've specified in the

BCD for the installation you're booting. If you boot into any safe mode, Winload sets the *safeboot* BCD option with a value describing the type of safe mode you select. For standard safe mode, Winload sets *minimal*, and for networking-enabled safe mode, it adds *network*. Winload adds *minimal* and sets *alternateshell* for safe mode with command prompt and *dsrepair* for Directory Services Restore mode.



Note An exception exists regarding the drivers that safe mode excludes from a boot. Winload, rather than the kernel, loads any drivers with a *Start* value of 0 in their registry key, which specifies loading the drivers at boot time. Winload doesn't check the *SafeBoot* registry key because it assumes that any driver with a *Start* value of 0 is required for the system to boot successfully. Because Winload doesn't check the *SafeBoot* registry key to identify which drivers to load, Winload loads all boot-start drivers (and later Ntoskrnl starts them).

The Windows kernel scans the boot parameters in search of the safe-mode switches at the end of phase 1 of the boot process (*Phase1InitializationDiscard*, see the "Kernel initialization phase 1" section earlier in this chapter), and sets the internal variable *InitSafeBootMode* to a value that reflects the switches it finds. During the *InitSafeBoot* function, the kernel writes the *InitSafeBootMode* value to the registry value HKLM\SYSTEM\CurrentControlSet\Control\SafeBoot\Option\OptionValue so that user-mode components, such as the SCM, can determine what boot mode the system is in. In addition, if the system is booting in safe mode with command prompt, the kernel sets the HKLM\SYSTEM\CurrentControlSet\Control\SafeBoot\Option\UseAlternateShell value to 1. The kernel records the parameters that Winload passes to it in the value HKLM\SYSTEM\CurrentControlSet\Control\SystemStartOptions.

When the I/O manager kernel subsystem loads device drivers that HKLM\SYSTEM\CurrentControlSet\Services specifies, the I/O manager executes the function *IopLoadDriver*. When the Plug and Play manager detects a new device and wants to dynamically load the device driver for the detected device, the Plug and Play manager executes the function *PipCallDriverAddDevice*. Both these functions call the function *IopSafebootDriverLoad* before they load the driver in question. *IopSafebootDriverLoad* checks the value of *InitSafeBootMode* and determines whether the driver should load. For example, if the system boots in standard safe mode, *IopSafebootDriverLoad* looks for the driver's group, if the driver has one, under the *Minimal* subkey. If *IopSafebootDriverLoad* finds the driver's group listed, *IopSafebootDriverLoad* indicates to its caller that the driver can load. Otherwise, *IopSafebootDriverLoad* looks for the driver's name under the *Minimal* subkey. If the driver's name is listed as a subkey, the driver can load. If *IopSafebootDriverLoad* can't find the driver group or driver name subkeys, the driver will not be loaded. If the system boots in networking-enabled safe mode, *IopSafebootDriverLoad* performs the searches on the *Network* subkey. If the system doesn't boot in safe mode, *IopSafebootDriverLoad* lets all drivers load.

Safe-mode-aware user programs

When the SCM user-mode component (which Services.exe implements) initializes during the boot process, the SCM checks the value of HKLM\SYSTEM\CurrentControlSet\Control\SafeBoot\Option\OptionValue to determine whether the system is performing a safe-mode boot. If so, the SCM mirrors the actions of *IopSafebootDriverLoad*. Although the SCM processes the services listed under HKLM\SYSTEM\CurrentControlSet\Services, it loads only services that the appropriate safe-mode

subkey specifies by name. You can find more information on the SCM initialization process in the section “Services” in Chapter 10.

Userinit, the component that initializes a user’s environment when the user logs on (%SystemRoot%\System32\Userinit.exe), is another user-mode component that needs to know whether the system is booting in safe mode. It checks the value of HKLM\SYSTEM\CurrentControlSet\Control\SafeBoot\Option\UseAlternateShell. If this value is set, Userinit runs the program specified as the user’s shell in the value HKLM\SYSTEM\CurrentControlSet\Control\SafeBoot\AlternateShell rather than executing Explorer.exe. Windows writes the program name Cmd.exe to the *AlternateShell* value during installation, making the Windows command prompt the default shell for safe mode with command prompt. Even though the command prompt is the shell, you can type **Explorer.exe** at the command prompt to start Windows Explorer, and you can run any other GUI program from the command prompt as well.

How does an application determine whether the system is booting in safe mode? By calling the Windows *GetSystemMetrics(SM_CLEANBOOT)* function. Batch scripts that need to perform certain operations when the system boots in safe mode look for the *SAFEBOOT_OPTION* environment variable because the system defines this environment variable only when booting in safe mode.

Boot status file

Windows uses a *boot status file* (%SystemRoot%\Bootstat.dat) to record the fact that it has progressed through various stages of the system life cycle, including boot and shutdown. This allows the Boot Manager, Windows loader, and Startup Repair tool to detect abnormal shutdown or a failure to shut down cleanly and offer the user recovery and diagnostic boot options, like the Windows Recovery environment. This binary file contains information through which the system reports the success of the following phases of the system life cycle:

- Boot
- Shutdown and hybrid shutdown
- Resume from hibernate or suspend

The boot status file also indicates whether a problem was detected the last time the user attempted to boot the operating system and the recovery options shown, indicating that the user has been made aware of the problem and taken action. Runtime Library APIs (Rtl) in Ntdll.dll contain the private interfaces that Windows uses to read from and write to the file. Like the BCD, it cannot be edited by users.

Conclusion

In this chapter, we examined the detailed steps involved in starting and shutting down Windows (both normally and in error cases). A lot of new security technologies have been designed and implemented with the goal of keeping the system safe even in its earlier startup stages and rendering it immune from a variety of external attacks. We examined the overall structure of Windows and the core system mechanisms that get the system going, keep it running, and eventually shut it down, even in a fast way.

APPENDIX

Contents of *Windows Internals, Seventh Edition, Part 1*

<i>Introduction</i>	<i>xi</i>
Chapter 1 Concepts and tools	1
Windows operating system versions	1
Windows 10 and future Windows versions	3
Windows 10 and OneCore	3
Foundation concepts and terms	4
Windows API	4
Services, functions, and routines	7
Processes	8
Threads	18
Jobs	20
Virtual memory	21
Kernel mode vs. user mode	23
Hypervisor	27
Firmware	29
Terminal Services and multiple sessions	29
Objects and handles	30
Security	31
Registry	32
Unicode	33
Digging into Windows internals	35
Performance Monitor and Resource Monitor	36
Kernel debugging	38
Windows Software Development Kit	43
Windows Driver Kit	43
Sysinternals tools	44
Conclusion	44

Chapter 2	System architecture	45
	Requirements and design goals	45
	Operating system model.....	46
	Architecture overview	47
	Portability.....	50
	Symmetric multiprocessing	51
	Scalability.....	53
	Differences between client and server versions.....	54
	Checked build	57
	Virtualization-based security architecture overview	59
	Key system components	61
	Environment subsystems and subsystem DLLs.....	62
	Other subsystems	68
	Executive.....	72
	Kernel.....	75
	Hardware abstraction layer.....	79
	Device drivers	82
	System processes.....	88
	Conclusion.....	99
Chapter 3	Processes and jobs	101
	Creating a process.....	101
	CreateProcess* functions arguments.....	102
	Creating Windows modern processes.....	103
	Creating other kinds of processes.....	104
	Process internals.....	105
	Protected processes	113
	Protected Process Light (PPL).....	115
	Third-party PPL support	119
	Minimal and Pico processes.....	120
	Minimal processes.....	120
	Pico processes.....	121
	Trustlets (secure processes).....	123
	Trustlet structure	123

Trustlet policy metadata	124
Trustlet attributes	125
System built-in Trustlets	125
Trustlet identity	126
Isolated user-mode services	127
Trustlet-accessible system calls	128
Flow of CreateProcess	129
Stage 1: Converting and validating parameters and flags	131
Stage 2: Opening the image to be executed	135
Stage 3: Creating the Windows executive process object	138
Stage 4: Creating the initial thread and its stack and context	144
Stage 5: Performing Windows subsystem-specific initialization ..	146
Stage 6: Starting execution of the initial thread	148
Stage 7: Performing process initialization in the context of the new process	148
Terminating a process	154
Image loader	155
Early process initialization	157
DLL name resolution and redirection	160
Loaded module database	164
Import parsing	168
Post-import process initialization	170
SwitchBack	171
API Sets	173
Jobs	176
Job limits	177
Working with a job	178
Nested jobs	179
Windows containers (server silos)	183
Conclusion	191

Chapter 4 Threads 193

Creating threads	193
Thread internals	194

Data structures	194
Birth of a thread	206
Examining thread activity	207
Limitations on protected process threads	212
Thread scheduling	214
Overview of Windows scheduling	214
Priority levels	215
Thread states	223
Dispatcher database	228
Quantum	231
Priority boosts	238
Context switching	255
Scheduling scenarios	256
Idle threads	260
Thread suspension	264
(Deep) freeze	264
Thread selection	266
Multiprocessor systems	268
Thread selection on multiprocessor systems	283
Processor selection	284
Heterogeneous scheduling (big.LITTLE)	286
Group-based scheduling	287
Dynamic fair share scheduling	289
CPU rate limits	292
Dynamic processor addition and replacement	295
Worker factories (thread pools)	297
Worker factory creation	298
Conclusion	300

Chapter 5 Memory management 301

Introduction to the memory manager	301
Memory manager components	302
Large and small pages	303
Examining memory usage	305

Internal synchronization	308
Services provided by the memory manager	309
Page states and memory allocations	310
Commit charge and commit limit	313
Locking memory	314
Allocation granularity	314
Shared memory and mapped files	315
Protecting memory	317
Data Execution Prevention	319
Copy-on-write	321
Address Windowing Extensions	323
Kernel-mode heaps (system memory pools)	324
Pool sizes	325
Monitoring pool usage	327
Look-aside lists	331
Heap manager	332
Process heaps	333
Heap types	334
The NT heap	334
Heap synchronization	334
The low-fragmentation heap	335
The segment heap	336
Heap security features	341
Heap debugging features	342
Pageheap	343
Fault-tolerant heap	347
Virtual address space layouts	348
x86 address space layouts	349
x86 system address space layout	352
x86 session space	353
System page table entries	355
ARM address space layout	356
64-bit address space layout	357
x64 virtual addressing limitations	359
Dynamic system virtual address space management	359

System virtual address space quotas	364
User address space layout	365
Address translation	371
x86 virtual address translation	371
Translation look-aside buffer	377
x64 virtual address translation	380
ARM virtual address translation	381
Page fault handling	383
Invalid PTEs	384
Prototype PTEs	385
In-paging I/O	386
Collided page faults	387
Clustered page faults	387
Page files	389
Commit charge and the system commit limit	394
Commit charge and page file size	397
Stacks	398
User stacks	399
Kernel stacks	400
DPC stack	401
Virtual address descriptors	401
Process VADs	402
Rotate VADs	403
NUMA	404
Section objects	405
Working sets	412
Demand paging	413
Logical prefetcher and ReadyBoot	413
Placement policy	416
Working set management	417
Balance set manager and swapper	421
System working sets	422
Memory notification events	423

Page frame number database	425
Page list dynamics	428
Page priority	436
Modified page writer and mapped page writer	438
PFN data structures	440
Page file reservation	443
Physical memory limits	446
Windows client memory limits	447
Memory compression	449
Compression illustration	450
Compression architecture	453
Memory partitions	456
Memory combining	459
The search phase	460
The classification phase	461
The page combining phase	462
From private to shared PTE	462
Combined pages release	464
Memory enclaves	467
Programmatic interface	468
Memory enclave initializations	469
Enclave construction	469
Loading data into an enclave	471
Initializing an enclave	472
Proactive memory management (SuperFetch)	472
Components	473
Tracing and logging	474
Scenarios	475
Page priority and rebalancing	476
Robust performance	478
ReadyBoost	479
ReadyDrive	480
Process reflection	480
Conclusion	482

Chapter 6 I/O system	483
I/O system components	483
The I/O manager	485
Typical I/O processing	486
Interrupt Request Levels and Deferred Procedure Calls	488
Interrupt Request Levels	488
Deferred Procedure Calls	490
Device drivers	492
Types of device drivers	492
Structure of a driver	498
Driver objects and device objects	500
Opening devices	507
I/O processing	510
Types of I/O	511
I/O request packets	513
I/O request to a single-layered hardware-based driver	525
I/O requests to layered drivers	533
Thread-agnostic I/O	536
I/O cancellation	537
I/O completion ports	541
I/O prioritization	546
Container notifications	552
Driver Verifier	552
I/O-related verification options	554
Memory-related verification options	555
The Plug and Play manager	559
Level of Plug and Play support	560
Device enumeration	561
Device stacks	563
Driver support for Plug and Play	569
Plug-and-play driver installation	571
General driver loading and installation	575
Driver loading	575
Driver installation	577

The Windows Driver Foundation	578
Kernel-Mode Driver Framework	579
User-Mode Driver Framework	587
The power manager	590
Connected Standby and Modern Standby	594
Power manager operation	595
Driver power operation	596
Driver and application control of device power	599
Power management framework	600
Power availability requests	602
Conclusion	603

Chapter 7 Security 605

Security ratings	605
Trusted Computer System Evaluation Criteria	605
The Common Criteria	607
Security system components	608
Virtualization-based security	611
Credential Guard	612
Device Guard	617
Protecting objects	619
Access checks	621
Security identifiers	625
Virtual service accounts	646
Security descriptors and access control	650
Dynamic Access Control	666
The AuthZ API	666
Conditional ACEs	667
Account rights and privileges	668
Account rights	669
Privileges	670
Super privileges	675
Access tokens of processes and threads	677

Security auditing	677
Object access auditing	679
Global audit policy	682
Advanced Audit Policy settings	683
AppContainers	684
Overview of UWP apps	685
The AppContainer	687
Logon	710
Winlogon initialization	711
User logon steps	713
Assured authentication	718
Windows Biometric Framework	719
Windows Hello	721
User Account Control and virtualization	722
File system and registry virtualization	722
Elevation	729
Exploit mitigations	735
Process-mitigation policies	735
Control Flow Integrity	740
Security assertions	752
Application Identification	756
AppLocker	757
Software Restriction Policies	762
Kernel Patch Protection	764
PatchGuard	765
HyperGuard	768
Conclusion	770
<i>Index</i>	771

Index

SYMBOLS

\ (root directory), 692

NUMBERS

32-bit handle table entry, 147

64-bit IDT, viewing, 34–35

A

AAM (Application Activation Manager), 244

ACL (access control list), displaying, 153–154

ACM (authenticated code module), 805–806

!acpiirqarb command, 49

ActivationObject object, 129

ActivityReference object, 129

address-based pushlocks, 201

address-based waits, 202–203

ADK (Windows Assessment and Deployment Kit), 421

administrative command prompt, opening, 253, 261

AeDebug and AeDebugProtected root keys, WER (Windows Error Reporting), 540

AES (Advanced Encryption Standard), 711

allocators, ReFS (Resilient File System), 743–745

ALPC (Advanced Local Procedure Call), 209

!alpc command, 224

ALPC message types, 211

ALPC ports, 129, 212–214

ALPC worker thread, 118

APC level, 40, 43, 62, 63, 65

!apciirqarb command, 48

APCs (asynchronous procedure calls), 61–66

APIC, and PIC (Programmable Interrupt Controller), 37–38

APIC (Advanced Programmable Interrupt Controller), 35–36

!apic command, 37

APIC Timer, 67

APIs, 690

\AppContainer NamedObjects directory, 160

AppContainers, 243–244

AppExecution aliases, 263–264

apps, activating through command line, 261–262. *See also* packaged applications

APT (Advanced Persistent Threats), 781

!arbiter command, 48

architectural system service dispatching, 92–95

\ArcName directory, 160

ARM32 simulation on ARM 64 platforms, 115

assembly code, 2

associative cache, 13

atomic execution, 207

attributes, resident and nonresident, 667–670

auto-expand pushlocks, 201

Autoruns tool, 837

autostart services startup, 451–457

AWE (Address Windowing Extension), 201

B

B+ Tree physical layout, ReFS (Resilient File System), 742–743

background tasks and Broker Infrastructure, 256–258

Background Broker Infrastructure

- Background Broker Infrastructure, 244, 256–258
 - backing up encrypted files, 716–717
 - bad-cluster recovery, NTFS recovery support, 703–706. *See also* clusters
 - bad-cluster remapping, NTFS, 633
 - base named objects, looking at, 163–164.
See also objects
 - \BaseNamedObjects directory, 160
 - BCD (Boot Configuration Database), 392, 398–399
 - BCD library for boot operations, 790–792
 - BCD options
 - Windows hypervisor loader (Hvloader), 796–797
 - Windows OS Loader, 792–796
 - bcdedit command, 398–399
 - BI (Background Broker Infrastructure), 244, 256–258
 - BI (Broker Infrastructure), 238
 - BindFlt (Windows Bind minifilter driver), 248
 - BitLocker
 - encryption offload, 717–718
 - recovery procedure, 801
 - turning on, 804
 - block volumes, DAX (Direct Access Disks), 728–730
 - BNO (Base Named Object) Isolation, 167
 - BOOLEAN status, 208
 - boot application, launching, 800–801
 - Boot Manager
 - BCD objects, 798
 - overview, 785–799
 - and trusted execution, 805
 - boot menu, 799–800
 - boot process. *See also* Modern boot menu
 - BIOS, 781
 - driver loading in safe mode, 848–849
 - hibernation and Fast Startup, 840–844
 - hypervisor loader, 811–813
 - images start automatically, 837
 - kernel and executive subsystems, 818–824
 - kernel initialization phase 1, 824–829
 - Measured Boot, 801–805
 - ReadyBoot, 835–836
 - safe mode, 847–850
 - Secure Boot, 781–784
 - Secure Launch, 816–818
 - shutdown, 837–840
 - Smss, Csrss, Wininit, 830–835
 - trusted execution, 805–807
 - UEFI, 777–781
 - VSM (Virtual Secure Mode) startup policy, 813–816
 - Windows OS Loader, 808–810
 - WinRE (Windows Recovery Environment), 845
 - boot status file, 850
 - Bootim.exe command, 832
 - booting from iSCSI, 811
 - BPB (boot parameter block), 657
 - BTB (Branch Target Buffer), 11
 - bugcheck, 40
- ## C
- C-states and timers, 76
 - cache
 - copying to and from, 584
 - forcing to write through to disk, 595
 - cache coherency, 568–569
 - cache data structures, 576–582
 - cache manager
 - in action, 591–594
 - centralized system cache, 567
 - disk I/O accounting, 600–601
 - features, 566–567
 - lazy writer, 622
 - mapping views of files, 573
 - memory manager, 567
 - memory partitions support, 571–572
 - NTFS MFT working set enhancements, 571
 - read-ahead thread, 622–623
 - recoverable file system support, 570

- stream-based caching, 569
- virtual block caching, 569
- write-back cache with lazy write, 589
- cache size, 574–576
- cache virtual memory management, 572–573
- cache-aware pushlocks, 200–201
- caches and storage memory, 10
- caching
 - with DMA (direct memory access) interfaces, 584–585
 - with mapping and pinning interfaces, 584
- caching and file systems
 - disks, 565
 - partitions, 565
 - sectors, 565
 - volumes, 565–566
- \Callback directory, 160
- cd command, 144, 832
- CDFS legacy format, 602
- CEA (Common Event Aggregator), 238
- Centennial applications, 246–249, 261
- CFG (Control Flow Integrity), 343
- Chain of Trust, 783–784
- change journal file, NTFS on-disk structure, 675–679
- change logging, NTFS, 637–638
- check-disk and fast repair, NTFS recovery support, 707–710
- checkpoint records, NTFS recovery support, 698
- !chksvctbl command, 103
- CHPE (Compile Hybrid Executable) bitmap, 115–118
- CIM (Common Information Model), WMI (Windows Management Instrumentation), 488–495
- CLFS (common logging file system), 403–404
- Clipboard User Service, 472
- clock time, 57
- cloning ReFS files, 755
- Close method, 141
- clusters. *See also* bad-cluster recovery

- defined, 566
- NTFS on-disk structure, 655–656
- cmd command, 253, 261, 275, 289, 312, 526, 832
- COM-hosted task, 479, 484–486
- command line, activating apps through, 261–262
- Command Prompt, 833, 845
- commands
 - !acpiirqarb, 49
 - !alpc, 224
 - !apciirqarb, 48
 - !apic, 37
 - !arbiter, 48
 - bcdedit, 398–399
 - Bootim.exe, 832
 - cd, 144, 832
 - !chksvctbl, 103
 - cmd, 253, 261, 275, 289, 312, 526, 832
 - db, 102
 - defrag.exe, 646
 - !devhandles, 151
 - !devnode, 49
 - !devobj, 48
 - dg, 7–8
 - dps, 102–103
 - dt, 7–8
 - dtrace, 527
 - .dumpdebug, 547
 - dx, 7, 35, 46, 137, 150, 190
 - .enumtag, 547
 - eventvwr, 288, 449
 - !exqueue, 83
 - fsutil resource, 693
 - fsutil storagereserve findById, 687
 - g, 124, 241
 - Get-FileStorageTier, 649
 - Get-VMPmemController, 737
 - !handle, 149
 - !idt, 34, 38, 46
 - !ioapic, 38
 - !irq, 41

commands (*continued*)

- k, 485
- link.exe/dump/loadconfig, 379
- !locks, 198
- msinfo32, 312, 344
- notepad.exe, 405
- !object, 137–138, 151, 223
- perfmon, 505, 519
- !pic, 37
- !process, 190
- !qllocks, 176
- !reg openkeys, 417
- regedit.exe, 468, 484, 542
- Runas, 397
- Set-PhysicalDisk, 774
- taskschd.msc, 479, 484
- !thread, 75, 190
- .tss, 8
- Wbemtest, 491
- wnfdump, 237
- committing a transaction, 697
- Composition object, 129
- compressing
 - nonsparse data, 673–674
 - sparse data, 671–672
- compression and ghosting, ReFS (Resilient File System), 769–770
- compression and sparse files, NTFS, 637
- condition variables, 205–206
- connection ports, dumping, 223–224
- container compaction, ReFS (Resilient File System), 766–769
- container isolation, support for, 626
- contiguous file, 643
- copying
 - to and from cache, 584
 - encrypted files, 717
- CoreMessaging object, 130
- corruption record, NTFS recovery support, 708
- CoverageSampler object, 129

- CPL (Code Privilege Level), 6
- CPU branch predictor, 11–12
- CPU cache(s), 9–10, 12–13
- crash dump files, WER (Windows Error Reporting), 543–548
- crash dump generation, WER (Windows Error Reporting), 548–551
- crash report generation, WER (Windows Error Reporting), 538–542
- crashes, consequences of, 421
- critical sections, 203–204
- CS (Code Segment)), 31
- Csrss, 830–835, 838–840

D

- data compression and sparse files, NTFS, 670–671
- data redundancy and fault tolerance, 629–630
- data streams, NTFS, 631–632
- data structures, 184–189
- DAX (Direct Access Disks). *See also* disks
 - block volumes, 728–730
 - cached and noncached I/O in volume, 723–724
 - driver model, 721–722
 - file system filter driver, 730–731
 - large and huge pages support, 732–735
 - mapping executable images, 724–728
 - overview, 720–721
 - virtual PMs and storage spaces support, 736–739
 - volumes, 722–724
- DAX file alignment, 733–735
- DAX mode I/Os, flushing, 731
- db command, 102
- /debug switch, FsTool, 734
- debugger
 - breakpoints, 87–88
 - objects, 241–242
 - !pte extension, 735
 - !trueref command, 148

- debugging. *See also* user-mode debugging
 - object handles, 158
 - trustlets, 374–375
 - WoW64 in ARM64 environments, 122–124
 - decryption process, 715–716
 - defrag.exe command, 646
 - defragmentation, NTFS, 643–645
 - Delete method, 141
 - Dependency Mini Repository, 255
 - Desktop object, 129
 - !devhandles command, 151
 - \Device directory, 161
 - device shims, 564
 - !devnode command, 49
 - !devobj command, 48
 - dg command, 4, 7–8
 - Directory object, 129
 - disk I/Os, counting, 601
 - disks, defined, 565. *See also* DAX (Direct Access Disks)
 - dispatcher routine, 121
 - DLLs
 - Hvloader.dll, 811
 - IUM (Isolated User Mode), 371–372
 - Ntevt.dll, 497
 - for Wow64, 104–105
 - DMA (Direct Memory Access), 50, 584–585
 - DMTF, WMI (Windows Management Instrumentation), 486, 489
 - DPC (dispatch or deferred procedure call) interrupts, 54–61, 71. *See also* software interrupts
 - DPC Watchdog, 59
 - dps (dump pointer symbol) command, 102–103
 - drive-letter name resolution, 620
 - \Driver directory, 161
 - driver loading in safe mode, 848–849
 - driver objects, 451
 - driver shims, 560–563
 - \DriverStore(s) directory, 161
 - dt command, 7, 47
 - DTrace (dynamic tracing)
 - ETW provider, 533–534
 - FBT (Function Boundary Tracing) provider, 531–533
 - initialization, 529–530
 - internal architecture, 528–534
 - overview, 525–527
 - PID (Process) provider, 531–533
 - symbol server, 535
 - syscall provider, 530
 - type library, 534–535
 - dtrace command, 527
 - .dump command, LiveKd, 545
 - dump files, 546–548
 - Dump method, 141
 - .dumpdebug command, 547
 - Duplicate object service, 136
 - DVRT (Dynamic Value Relocation Table), 23–24, 26
 - dx command, 7, 35, 46, 137, 150, 190
 - Dxgk* objects, 129
 - dynamic memory, tracing, 532–533
 - dynamic partitioning, NTFS, 646–647
- ## E
- EFI (Extensible Firmware Interface), 777
 - EFS (Encrypting File System)
 - architecture, 712
 - BitLocker encryption offload, 717–718
 - decryption process, 715–716
 - described, 640
 - first-time usage, 713–715
 - information and key entries, 713
 - online support, 719–720
 - overview, 710–712
 - recovery agents, 714
 - EFS information, viewing, 716
 - EIP program counter, 8
 - enclave configuration, dumping, 379–381

encrypted files

- encrypted files
 - backing up, 716–717
 - copying, 717
 - encrypting file data, 714–715
 - encryption NTFS, 640
 - encryption support, online, 719–720
 - EnergyTracker object, 130
 - enhanced timers, 78–81. *See also* timers
 - /enum command-line parameter, 786
 - .enumtag command, 547
 - Error Reporting. *See* WER (Windows Error Reporting)
 - ETL file, decoding, 514–515
 - ETW (Event Tracing for Windows). *See also* tracing dynamic memory
 - architecture, 500
 - consuming events, 512–515
 - events decoding, 513–515
 - Global logger and autologgers, 521
 - and high-frequency timers, 68–70
 - initialization, 501–502
 - listing processes activity, 510
 - logger thread, 511–512
 - overview, 499–500
 - providers, 506–509
 - providing events, 509–510
 - security, 522–525
 - security registry key, 503
 - sessions, 502–506
 - system loggers, 516–521
 - ETW provider, DTrace (dynamic tracing), 533–534
 - ETW providers, enumerating, 508
 - ETW sessions
 - default security descriptor, 523–524
 - enumerating, 504–506
 - ETW_GUID_ENTRY data structure, 507
 - ETW_REG_ENTRY, 507
 - EtwConsumer object, 129
 - EtwRegistration object, 129
 - Event Log provider DLL, 497
 - Event object, 128
 - Event Viewer tool, 288
 - eventvwr command, 288, 449
 - ExAllocatePool* function, 26
 - exception dispatching, 85–91
 - executive mutexes, 196–197
 - executive objects, 126–130
 - executive resources, 197–199
 - exFAT, 606
 - explicit file I/O, 619–622
 - export thunk, 117
 - !exqueue command, 83
- ## F
- F5 key, 124, 397
 - fast I/O, 585–586. *See also* I/O system
 - fast mutexes, 196–197
 - fast repair and check-disk, NTFS recovery support, 707–710
 - Fast Startup and hibernation, 840–844
 - FAT12, FAT16, FAT32, 603–606
 - FAT64, 606
 - Fault Reporting process, WER (Windows Error Reporting), 540
 - fault tolerance and data redundancy, NTFS, 629–630
 - FCB (File Control Block), 571
 - FCB Headers, 201
 - feature settings and values, 22–23
 - FEK (File Encryption Key), 711
 - file data, encrypting, 714–715
 - file names, NTFS on-disk structure, 664–666
 - file namespaces, 664
 - File object, 128
 - file record numbers, NTFS on-disk structure, 660
 - file records, NTFS on-disk structure, 661–663
 - file system drivers, 583
 - file system formats, 566
 - file system interfaces, 582–585
 - File System Virtualization, 248

file systems

- CDFS, 602
- data-scan sections, 624–625
- drivers architecture, 608
- exFAT, 606
- explicit file I/O, 619–622
- FAT12, FAT16, FAT32, 603–606
- filter drivers, 626
- filter drivers and minifilters, 623–626
- filtering named pipes and mailslots, 625
- FSDs (file system drivers), 608–617
- mapped page writers, 622
- memory manager, 622
- NTFS file system, 606–607
- operations, 618
- Process Monitor, 627–628
- ReFS (Resilient File System), 608
- remote FSDs, 610–617
- reparse point behavior, 626
- UDF (Universal Disk Format), 603

\FileSystem directory, 161

fill buffers, 17

Filter Manager, 626

FilterCommunicationPort object, 130

FilterConnectionPort object, 130

Flags, 132

flushing mapped files, 595–596

Foreshadow (L1TF) attack, 16

fragmented file, 643

FSCTL (file system control) interface, 688

FSDs (file system drivers), 608–617

FsTool, /debug switch, 734

fsutil resource command, 693

fsutil storagereserve findById command, 687

G

g command, 124, 241

gadgets, 15

GDI/User objects, 126–127. *See also*
user-mode debugging

GDT (Global Descriptor Table), 2–5

Get-FileStorageTier command, 649

Get-VMPmemController command, 737

Gflags.exe, 554–557

GIT (Generic Interrupt Timer), 67

\GLOBAL?? directory, 161

global flags, 554–557

global namespace, 167

GPA (guest physical address), 17

GPIO (General Purpose Input Output), 51

GSIV (global system interrupt vector), 32, 51

guarded mutexes, 196–197

GUI thread, 96

H

HAM (Host Activity Manager), 244, 249–251

!handle command, 149

Handle count, 132

handle lists, single instancing, 165

handle tables, 146, 149–150

handles

- creating maximum number of, 147
- viewing, 144–145

hard links, NTFS, 634

hardware indirect branch controls, 21–23

hardware interrupt processing, 32–35

hardware side-channel vulnerabilities, 9–17

hibernation and Fast Startup, 840–844

high-IRQL synchronization, 172–177

hive handles, 410

hives. *See also* registry

- loading, 421
- loading and unloading, 408
- reorganization, 414–415

HKEY_CLASSES_ROOT, 397–398

HKEY_CURRENT_CONFIG, 400

HKEY_CURRENT_USER subkeys, 395

HKEY_LOCAL_MACHINE, 398–400

HKEY_PERFORMANCE_DATA, 401

HKEY_PERFORMANCE_TEXT, 401

- HKEY_USERS, 396
 - HKLM\SYSTEM\CurrentControlSet\Control\SafeBoot registry key, 848
 - HPET (High Performance Event Timer), 67
 - hung program screen, 838
 - HungAppTimeout, 839
 - HVCI (Hypervisor Enforced Code Integrity), 358
 - hybrid code address range table, dumping, 117–118
 - hybrid shutdown, 843–844
 - hypercalls and hypervisor TLFS (Top Level Functional Specification), 299–300
 - Hyper-V schedulers. *See also* Windows hypervisor
 - classic, 289–290
 - core, 291–294
 - overview, 287–289
 - root scheduler, 294–298
 - SMT system, 292
 - hypervisor debugger, connecting, 275–277
 - hypervisor loader boot module, 811–813
- I**
- IBPB (Indirect Branch Predictor Barrier), 22, 25
 - IBRS (Indirect Branch Restricted Speculation), 21–22, 25
 - IDT (interrupt dispatch table), 32–35
 - !idt command, 34, 38, 46
 - images starting automatically, 837
 - Import Optimization and Retpoline, 23–26
 - indexing facility, NTFS, 633, 679–680
 - Info mask, 132
 - Inheritance object service, 136
 - integrated scheduler, 294
 - interlocked operations, 172
 - interrupt control flow, 45
 - interrupt dispatching
 - hardware interrupt processing, 32–35
 - overview, 32
 - programmable interrupt controller architecture, 35–38
 - software IRQs (interrupt request levels), 38–50
 - interrupt gate, 32
 - interrupt internals, examining, 46–50
 - interrupt objects, 43–50
 - interrupt steering, 52
 - interrupt vectors, 42
 - interrupts
 - affinity and priority, 52–53
 - latency, 50
 - masking, 39
 - I/O system, components of, 652. *See also* Fast I/O
 - IOAPIC (I/O Advanced Programmable Interrupt Controller), 32, 36
 - !ioapic command, 38
 - IoCompletion object, 128
 - IoCompletionReserve object, 128
 - Ionescu, Alex, 28
 - IRPs (I/O request packets), 567, 583, 585, 619, 621–624, 627, 718
 - IRQ affinity policies, 53
 - IRQ priorities, 53
 - IRQL (interrupt request levels), 347–348. *See also* software IRQs (interrupt request levels)
 - !irq command, 41
 - IRTimer object, 128
 - iSCSI, booting from, 811
 - isolation, NTFS on-disk structure, 689–690
 - ISR (interrupt service routine), 31
 - IST (Interrupt Stack Table), 7–9
 - IUM (Isolated User Mode)
 - overview, 371–372
 - SDF (Secure Driver Framework), 376
 - secure companions, 376
 - secure devices, 376–378
 - SGRA (System Guard Runtime attestation), 386–390
 - trustlets creation, 372–375
 - VBS-based enclaves, 378–386

J

jitted blocks, 115, 117
 jitting and execution, 121–122
 Job object, 128

K

k command, 485
 Kali Linux, 247
KeBugCheckEx system function, 32
 KEK (Key Exchange Key), 783
 kernel. *See also* Secure Kernel
 dispatcher objects, 179–181
 objects, 126
 spinlocks, 174
 synchronization mechanisms, 179
 kernel addresses, mapping, 20
 kernel debugger
 !handle extension, 125
 !locks command, 198
 searching for open files with, 151–152
 viewing handle table with, 149–150
 kernel logger, tracing TCP/IP activity with,
 519–520
 Kernel Patch Protection, 24
 kernel reports, WER (Windows Error
 Reporting), 551
 kernel shims
 database, 559–560
 device shims, 564
 driver shims, 560–563
 engine initialization, 557–559
 shim database, 559–560
 witnessing, 561–563
 kernel-based system call dispatching, 97
 kernel-mode debugging events, 240
 \KernelObjects directory, 161
 Key object, 129
 keyed events, 194–196
 KeyedEvent object, 128
 KilsrThunk, 33

KINTERRUPT object, 44, 46
 \KnownDlls directory, 161
 \KnownDlls32 directory, 161
 KPCR (Kernel Processor Control Region), 4
 KPRCB fields, timer processing, 72
 KPTI (Kernel Page Table Isolation), 18
 KTM (Kernel Transaction Manager), 157, 688
 KVA Shadow, 18–21

L

L1TF (Foreshadow) attack, 16
 LAPIC (Local Advanced Programmable
 Interrupt Controllers), 32
 lazy jitter, 119
 lazy segment loading, 6
 lazy writing
 disabling, 595
 and write-back caching, 589–595
 LBA (logical block address), 589
 LCNs (logical cluster numbers), 656–658
 leak detections, ReFS (Resilient File System),
 761–762
 leases, 614–615, 617
 LFENCE, 23
 LFS (log file service), 652, 695–697
 line-based versus message signaled-based
 interrupts, 50–66
 link tracking, NTFS, 639
 link.exe tool, 117, 379
 link.exe/dump/loadconfig command, 379
 LiveKd, .dump command, 545
 load ports, 17
 loader issues, troubleshooting, 556–557
 Loader Parameter block, 819–821
 local namespace, 167
 local procedure call
 ALPC direct event attribute, 222
 ALPC port ownership, 220
 asynchronous operation, 214–215
 attributes, 216–217
 blobs, handles, and resources, 217–218

local procedure call

- local procedure call (*continued*)
 - connection model, 210–212
 - debugging and tracing, 222–224
 - handle passing, 218–219
 - message model, 212–214
 - overview, 209–210
 - performance, 220–221
 - power management, 221
 - security, 219–220
 - views, regions, and sections, 215–216
- Lock, 132
- !locks command, kernel debugger, 198
- log record types, NTFS recovery support, 697–699
- \$LOGGED_UTILITY_STREAM attribute, 663
- logging implementation, NTFS on-disk structure, 693
- Low-IRQL synchronization. *See also* synchronization
 - address-based waits, 202–203
 - condition variables, 205–206
 - critical sections, 203–204
 - data structures, 184–194
 - executive resources, 197–202
 - kernel dispatcher objects, 179–181
 - keyed events, 194–196
 - mutexes, 196–197
 - object-less waiting (thread alerts), 183–184
 - overview, 177–179
 - run once initialization, 207–208
 - signalling objects, 181–183
 - (SRW) Slim Reader/Writer locks, 206–207
 - user-mode resources, 205
- LRC parity and RAID 6, 773
- LSASS (Local Security Authority Subsystem Service) process, 453, 465
- LSN (logical sequence number), 570

M

- mapped files, flushing, 595–596
- mapping and pinning interfaces, caching with, 584
- masking interrupts, 39
- MBEC (Mode Base Execution Controls), 93
- MDL (Memory Descriptor List), 220
- MDS (Microarchitectural Data Sampling), 17
- Measured Boot, 801–805
- media mixer, creating, 165
- Meltdown attack, 14, 18
- memory, sharing, 171
- memory hierarchy, 10
- memory manager
 - modified and mapped page writer, 622
 - overview, 567
 - page fault handler, 622–623
- memory partitions support, 571–572
- metadata
 - defined, 566, 570
- metadata logging, NTFS recovery support, 695
- MFT (Master File Table)
 - NTFS metadata files in, 657
 - NTFS on-disk structure, 656–660
 - record for small file, 661
- MFT file records, 668–669
- MFT records, compressed file, 674
- Microsoft Incremental linker ((link.exe)), 117
- minifilter driver, Process Monitor, 627–628
- Minstore architecture, ReFS (Resilient File System), 740–742
- Minstore I/O, ReFS (Resilient File System), 746–748
- Minstore write-ahead logging, 758
- Modern Application Model, 249, 251, 262
- modern boot menu, 832–833. *See also* boot process
- MOF (Managed Object Format), WMI (Windows Management Instrumentation), 488–495
- MPS (Multiprocessor Specification), 35
- Mscconfig utility, 837

MSI (message signaled interrupts), 50–66
 msinfo32 command, 312, 344
 MSRs (model specific registers), 92
 Mutex object, 128
 mutexes, fast and guarded, 196–197
 mutual exclusion, 170

N

named pipes and mailslots, filtering, 625
 namespace instancing, viewing, 169
 \NLS directory, 161
 nonarchitectural system service dispatching, 96–97
 nonparse data, compressing, 673–674
 notepad.exe command, 405
 notifications. *See* WNF (Windows Notification Facility)
 NT kernel, 18–19, 22
 Ntdll version list, 106
 Ntevt.dll, 497
 NTFS bad-cluster recovery, 703–706
 NTFS file system

- advanced features, 630
- change logging, 637–638
- compression and sparse files, 637
- data redundancy, 629–630
- data streams, 631–632
- data structures, 654
- defragmentation, 643–646
- driver, 652–654
- dynamic bad-cluster remapping, 633
- dynamic partitioning, 646–647
- encryption, 640
- fault tolerance, 629–630
- hard links, 634
- high-end requirements, 628
- indexing facility, 633
- link tracking, 639
- metadata files in MFT, 657
- overview, 606–607
- per-user volume quotas, 638–639

POSIX deletion, 641–643
 recoverability, 629
 recoverable file system support, 570
 and related components, 653
 security, 629
 support for tiered volumes, 647–651
 symbolic links and junctions, 634–636
 Unicode-based names, 633
 NTFS files, attributes for, 662–663
 NTFS information, viewing, 660
 NTFS MFT working set enhancements, 571
 NTFS on-disk structure

- attributes, 667–670
- change journal file, 675–679
- clusters, 655–656
- consolidated security, 682–683
- data compression and sparse files, 670–674
- on-disk implementation, 691–693
- file names, 664–666
- file record numbers, 660
- file records, 661–663
- indexing, 679–680
- isolation, 689–690
- logging implementation, 693
- master file table, 656–660
- object IDs, 681
- overview, 654
- quota tracking, 681–682
- reparse points, 684–685
- sparse files, 675
- Storage Reserves and reservations, 685–688
- transaction support, 688–689
- transactional APIs, 690
- tunneling, 666–667
- volumes, 655

 NTFS recovery support

- analysis pass, 700
- bad clusters, 703–706
- check-disk and fast repair, 707–710
- design, 694–695
- LFS (log file service), 695–697

NTFS recovery support

NTFS recovery support (*continued*)

- log record types, 697–699

- metadata logging, 695

- recovery, 699–700

- redo pass, 701

- self-healing, 706–707

- undo pass, 701–703

NTFS reservations and Storage Reserves, 685–688

Ntoskrnl and Winload, 818

NVMe (Non-volatile Memory disk), 565

O

!object command, 137–138, 151, 223

Object Create Info, 132

object handles, 146, 158

object IDs, NTFS on-disk structure, 681

Object Manager

- executive objects, 127–130

- overview, 125–127

- resource accounting, 159

- symbolic links, 166–170

Object type index, 132

object-less waiting (thread alerts), 183–184

objects. *See also* base named objects; private

- objects; reserve objects

- directories, 160–165

- filtering, 170

- flags, 134–135

- handles and process handle table, 143–152

- headers and bodies, 131–136

- methods, 140–143

- names, 159–160

- reserves, 152–153

- retention, 155–158

- security, 153–155

- services, 136

- signalling, 181–183

- structure, 131

- temporary and permanent, 155

- types, 126, 136–140

\ObjectTypes directory, 161

ODBC (Open Database Connectivity),
WMI (Windows Management
Instrumentation), 488

Okay to close method, 141

on-disk implementation, NTFS on-disk
structure, 691–693

open files, searching for, 151–152

open handles, viewing, 144–145

Open method, 141

Openfiles/query command, 126

oplocks and FSDs, 611–612, 616

Optimize Drives tool, 644–645

OS/2 operating system, 130

out-of-order execution, 10–11

P

packaged applications. *See also* apps

- activation, 259–264

- BI (Background Broker Infrastructure),
256–258

- bundles, 265

- Centennial, 246–249

- Dependency Mini Repository, 255

- Host Activity Manager, 249–251

- overview, 243–245

- registration, 265–266

- scheme of lifecycle, 250

- setup and startup, 258

- State Repository, 251–254

- UWP, 245–246

page table, ReFS (Resilient File System),
745–746

PAN (Privileged Access Neven), 57

Parse method, 141

Partition object, 130

partitions

- caching and file systems, 565

- defined, 565

Pc Reset, 845

PCIDs (Process-Context Identifiers), 20

PEB (process environment block), 104
 per-file cache data structures, 579–582
 perfmon command, 505, 519
 per-user volume quotas, NTFS, 638–639
 PFN database, physical memory removed from, 286
 PIC (Programmable Interrupt Controller), 35–38
 !pic command, 37
 pinning and mapping interfaces, caching with, 584
 pinning the bucket, ReFS (Resilient File System), 743
 PIT (Programmable Interrupt Timer), 66–67
 PM (persistent memory), 736
 Pointer count field, 132
 pop thunk, 117
 POSIX deletion, NTFS, 641–643
 PowerRequest object, 129
 private objects, looking at, 163–164.
 See also objects
 Proactive Scan maintenance task, 708–709
 !process command, 190
 Process Explorer, 58, 89–91, 144–145, 147, 153–154, 165–169
 Process Monitor, 591–594, 627–628, 725–728
 Process object, 128, 137
 processor execution model, 2–9
 processor selection, 73–75
 processor traps, 33
 Profile object, 130
 PSM (Process State Manager), 244
 !pte extension of debugger, 735
 PTEs (Page table entries), 16, 20
 push thunk, 117
 pushlocks, 200–202

Q

!qllocks command, 176
 Query name method, 141
 Query object service, 136
 Query security object service, 136

queued spinlocks, 175–176
 quota tracking, NTFS on-disk structure, 681–682

R

RAID 6 and LRC parity, 773
 RAM (Random Access Memory), 9–11
 RawInputManager object, 130
 RDCL (Rogue Data Cache load), 14
 Read (R) access, 615
 read-ahead and write-behind
 cache manager disk I/O accounting, 600–601
 disabling lazy writing, 595
 dynamic memory, 599–600
 enhancements, 588–589
 flushing mapped files, 595–596
 forcing cache to write through disk, 595
 intelligent read-ahead, 587–588
 low-priority lazy writes, 598–599
 overview, 586–587
 system threads, 597–598
 write throttling, 596–597
 write-back caching and lazy writing, 589–594
 reader/writer spinlocks, 176–177
 ReadyBoost driver service settings, 810
 ReadyBoot, 835–836
 Reconciler, 419–420
 recoverability, NTFS, 629
 recoverable file system support, 570
 recovery, NTFS recovery support, 699–700.
 See also WinRE (Windows Recovery Environment)
 redo pass, NTFS recovery support, 701
 ReFS (Resilient File System)
 allocators, 743–745
 architecture's scheme, 749
 B+ tree physical layout, 742–743
 compression and ghosting, 769–770
 container compaction, 766–769

ReFS (Resilient File System)

ReFS (Resilient File System) *(continued)*

- data integrity scanner, 760
- on-disk structure, 751–752
- file integrity streams, 760
- files and directories, 750
- file's block cloning and spare VDL, 754–757
- leak detections, 761–762
- Minstore architecture, 740–742
- Minstore I/O, 746–748
- object IDs, 752–753
- overview, 608, 739–740, 748–751
- page table, 745–746
- pinning the bucket, 743
- recovery support, 759–761
- security and change journal, 753–754
- SMR (shingled magnetic recording) volumes, 762–766
- snapshot support through HyperV, 756–757
- tiered volumes, 764–766
- write-through, 757–758
- zap and salvage operations, 760
- ReFS files, cloning, 755
- !reg openkeys command, 417
- regedit.exe command, 468, 484, 542
- registered file systems, 613–614
- registry. *See also* hives
 - application hives, 402–403
 - cell data types, 411–412
 - cell maps, 413–414
 - CLFS (common logging file system), 403–404
 - data types, 393–394
 - differencing hives, 424–425
 - filtering, 422
 - hive structure, 411–413
 - hives, 406–408
 - HKEY_CLASSES_ROOT, 397–398
 - HKEY_CURRENT_CONFIG, 400
 - HKEY_CURRENT_USER subkeys, 395
 - HKEY_LOCAL_MACHINE, 398–400
 - HKEY_PERFORMANCE_DATA, 401
 - HKEY_PERFORMANCE_TEXT, 401
 - HKEY_USERS, 396
 - HKLM\SYSTEM\CurrentControlSet\Control\SafeBoot key, 848
- incremental logging, 419–421
- key control blocks, 417–418
- logical structure, 394–401
- modifying, 392–393
- monitoring activity, 404
- namespace and operation, 415–418
- namespace redirection, 423
- optimizations, 425–426
- Process Monitor, 405–406
- profile loading and unloading, 397
- Reconciler, 419–420
- remote BCD editing, 398–399
- reorganization, 414–415
- root keys, 394–395
- ServiceGroupOrder key, 452
- stable storage, 418–421
- startup and process, 408–414
- symbolic links, 410
- TxR (Transactional Registry), 403–404
- usage, 392–393
- User Profiles, 396
- viewing and changing, 391–392
- virtualization, 422–425
- RegistryTransaction object, 129
- reparse points, 626, 684–685
- reserve objects, 152–153. *See also* objects
- resident and nonresident attributes, 667–670
- resource manager information, querying, 692–693
- Resource Monitor, 145
- Restricted User Mode, 93
- Retpoline and Import optimization, 23–26
- RH (Read-Handle) access, 615
- RISC (Reduced Instruction Set Computing), 113
- root directory (\), 692
- \RPC Control directory, 161
- RSA (Rivest-Shamir-Adleman) public key algorithm, 711

RTC (Real Time Clock), 66–67
 run once initialization, 207–208
 Runas command, 397
 runtime drivers, 24
 RW (Read-Write) access, 615
 RWH (Read-Write-Handle) access, 615

S

safe mode, 847–850
 SCM (Service Control Manager)
 network drive letters, 450
 overview, 446–449
 and Windows services, 426–428
 SCM Storage driver model, 722
 SCP (service control program), 426–427
 SDB (shim database), 559–560
 SDF (Secure Driver Framework), 376
 searching for open files, 151–152
 SEB (System Events Broker), 226, 238
 second-chance notification, 88
 Section object, 128
 sectors
 caching and file systems, 565
 and clusters on disk, 566
 defined, 565
 secure boot, 781–784
 Secure Kernel. *See also* kernel
 APs (application processors) startup,
 362–363
 control over hypercalls, 349
 hot patching, 368–371
 HVCI (Hypervisor Enforced Code
 Integrity), 358
 memory allocation, 367–368
 memory manager, 363–368
 NAR data structure, 365
 overview, 345
 page identity/secure PFN database,
 366–367
 secure intercepts, 348–349
 secure IRQs, 347–348
 secure threads and scheduling, 356–358
 Syscall selector number, 354
 trustlet for normal call, 354
 UEFI runtime virtualization, 358–360
 virtual interrupts, 345–348
 VSM startup, 360–363
 VSM system calls, 349–355
 Secure Launch, 816–818
 security consolidation, NTFS on-disk structure,
 682–683
 Security descriptor field, 132
 \Security directory, 161
 Security method, 141
 security reference monitor, 153
 segmentation, 2–6
 self-healing, NTFS recovery support, 706–707
 Semaphore object, 128
 service control programs, 450–451
 service database, organization of, 447
 service descriptor tables, 100–104
 ServiceGroupOrder registry key, 452
 services logging, enabling, 448–449
 session namespace, 167–169
 Session object, 130
 \Sessions directory, 161
 Set security object service, 136
 /setbootorder command-line parameter, 788
 Set-PhysicalDisk command, 774
 SGRA (System Guard Runtime attestation),
 386–390
 SGX, 16
 shadow page tables, 18–20
 shim database, 559–560
 shutdown process, 837–840
 SID (security identifier), 162
 side-channel attacks
 L1TF (Foreshadow), 16
 MDS (Microarchitectural Data Sampling), 17
 Meltdown, 14
 Spectre, 14–16
 SSB (speculative store bypass), 16

Side-channel mitigations in Windows

- Side-channel mitigations in Windows
 - hardware indirect branch controls, 21–23
 - KVA Shadow, 18–21
 - Retpoline and import optimization, 23–26
 - STIPB pairing, 26–30
- Signal an object and wait for another service, 136
- Sihost process, 834
- \Silo directory, 161
- SKINIT and Secure Launch, 816, 818
- SkTool, 28–29
- SLAT (Second Level Address Translation) table, 17
- SMAP (Supervisor Mode Access Protection), 57, 93
- SMB protocol, 614–615
- SMP (symmetric multiprocessing), 171
- SMR (shingled magnetic recording) volumes, 762–763
- SMR disks tiers, 765–766
- Smss user-mode process, 830–835
- SMT system, 292
- software interrupts. *See also* DPC (dispatch or deferred procedure call) interrupts
 - APCs (asynchronous procedure calls), 61–66
 - DPC (dispatch or deferred procedure call), 54–61
 - overview, 54
- software IRQLs (interrupt request levels), 38–50. *See also* IRQL (interrupt request levels)
- Spaces. *See* Storage Spaces
- sparse data, compressing, 671–672
- sparse files
 - and data compression, 670–671
 - NTFS on-disk structure, 675
- Spectre attack, 14–16
- SpecuCheck tool, 28–29
- SpeculationControl PowerShell script, 28
- spinlocks, 172–177
- Spot Verifier service, NTFS recovery support, 708
- spurious traps, 31
- SQLite databases, 252
- SRW (Slim Read Writer) Locks, 178, 195, 205–207
- SSB (speculative store bypass), 16
- SSBD (Speculative Store Bypass Disable), 22
- SSD (solid-state disk), 565, 644–645
- SSD volume, retrimming, 646
- Startup Recovery tool, 846
- Startup Repair, 845
- State Repository, 251–252
- state repository, witnessing, 253–254
- STIBP (Single Thread Indirect Branch Predictors), 22, 25–30
- Storage Reserves and NTFS reservations, 685–688
- Storage Spaces
 - internal architecture, 771–772
 - overview, 770–771
 - services, 772–775
- store buffers, 17
- stream-based caching, 569
- structured exception handling, 85
- Svchost service splitting, 467–468
- symbolic links, 166
- symbolic links and junctions, NTFS, 634–637
- SymbolicLink object, 129
- symmetric encryption, 711
- synchronization. *See also* Low-IRQL synchronization
 - High-IRQL, 172–177
 - keyed events, 194–196
 - overview, 170–171
- syscall instruction, 92
- system call numbers, mapping to functions and arguments, 102–103
- system call security, 99–100
- system call table compaction, 101–102
- system calls and exception dispatching, 122
- system crashes, consequences of, 421
- System Image Recover, 845
- SYSTEM process, 19–20
- System Restore, 845
- system service activity, viewing, 104
- system service dispatch table, 96

- system service dispatcher, locating, 94–95
- system service dispatching, 98
- system service handling
 - architectural system service dispatching, 92–95
 - overview, 91
- system side-channel mitigation status, querying, 28–30
- system threads, 597–598
- system timers, listing, 74–75. *See also* timers
- system worker threads, 81–85

T

- take state segments, 6–9
- Task Manager, starting, 832
- Task Scheduler
 - boot task master key, 478
 - COM interfaces, 486
 - initialization, 477–481
 - overview, 476–477
 - Triggers and Actions, 478
 - and UBPM (Unified Background Process Manager), 481–486
 - XML descriptor, 479–481
- task scheduling and UBPM, 475–476
- taskschd.msc command, 479, 484
- TBOOT module, 806
- TCP/IP activity, tracing with kernel logger, 519–520
- TEB (Thread Environment Block), 4–5, 104
- Terminal object, 130
- TerminalEventQueue object, 130
- thread alerts (object-less waiting), 183–184
- !thread command, 75, 190
- thread-local register effect, 4. *See also* Windows threads
- thunk kernel routines, 33
- tiered volumes. *See also* volumes
 - creating maximum number of, 774–775
 - support for, 647–651
- Time Broker, 256
- timer coalescing, 76–77
- timer expiration, 70–72
- timer granularity, 67–70
- timer lists, 71
- Timer object, 128
- timer processing, 66
- timer queuing behaviors, 73
- timer serialization, 73
- timer tick distribution, 75–76
- timer types
 - and intervals, 66–67
 - and node collection indices, 79
- timers. *See also* enhanced timers; system timers
 - high frequency, 68–70
 - high resolution, 80
- TLB flushing algorithm, 18, 20–21, 272
- TmEn object, 129
- TmRm object, 129
- TmTm object, 129
- TmTx object, 129
- Token object, 128
- TPM (Trusted Platform Module), 785, 800–801
- TPM measurements, invalidating, 803–805
- TpWorkerFactory object, 129
- TR (Task Register), 6, 32
- Trace Flags field, 132
- tracing dynamic memory, 532–533. *See also* DTrace (dynamic tracing); ETW (Event Tracing for Windows)
- transaction support, NTFS on-disk structure, 688–689
- transactional APIs, NTFS on-disk structure, 690
- transactions
 - committing, 697
 - undoing, 702
- transition stack, 18
- trap dispatching
 - exception dispatching, 85–91
 - interrupt dispatching, 32–50
 - line-based interrupts, 50–66
 - message signaled-based interrupts, 50–66

trap dispatching

- trap dispatching (*continued*)
 - overview, 30–32
 - system service handling, 91–104
 - system worker threads, 81–85
 - timer processing, 66–81
- TRIM commands, 645
- troubleshooting Windows loader issues, 556–557
- !trueref debugger command, 148
- trusted execution, 805–807
- trustlets
 - creation, 372–375
 - debugging, 374–375
 - secure devices, 376–378
 - Secure Kernel and, 345
 - secure system calls, 354
 - VBS-based enclaves, 378
 - in VTL 1, 371
 - Windows hypervisor on ARM64, 314–315
- TSS (Task State Segment), 6–9
- .tss command, 8
- tunneling, NTFS on-disk structure, 666–667
- TxF APIs, 688–690
- \$TXF_DATA attribute, 691–692
- TXT (Trusted Execution Technology), 801, 805–807, 816
- type initializer fields, 139–140
- type objects, 131, 136–140

U

- UBPM (Unified Background Process Manager), 481–486
- UDF (Universal Disk Format), 603
- UEFI boot, 777–781
- UEFI runtime virtualization, 358–363
- UMDF (User-Mode Driver Framework), 209
- \UMDFCommunicationPorts directory, 161
- undo pass, NTFS recovery support, 701–703
- unexpected traps, 31
- Unicode-based names, NTFS, 633
- user application crashes, 537–542

- User page tables, 18
- UserApcReserve object, 130
- user-issued system call dispatching, 98
- user-mode debugging. *See also* debugging;
GDI/User objects
 - kernel support, 239–240
 - native support, 240–242
 - Windows subsystem support, 242–243
- user-mode resources, 205
- UWP (Universal Windows Platform)
 - and application hives, 402
 - application model, 244
 - bundles, 265
 - and SEB (System Event Broker), 238
 - services to apps, 243
- UWP applications, 245–246, 259–260

V

- VACBs (virtual address control blocks), 572, 576–578, 581–582
- VBO (virtual byte offset), 589
- VBR (volume boot record), 657
- VBS (virtualization-based security)
 - detecting, 344
 - overview, 340
 - VSM (Virtual Secure Mode), 340–344
 - VTLs (virtual trust levels), 340–342
- VCNs (virtual cluster numbers), 656–658, 669–672
- VHDPMEM image, creating and mounting, 737–739
- virtual block caching, 569
- virtual PMs architecture, 736
- virtualization stack
 - deferred commit, 339
 - EPF (enlightened page fault), 339
 - explained, 269
 - hardware support, 329–335
 - hardware-accelerated devices, 332–335
 - memory access hints, 338
 - memory-zeroing enlightenments, 338

- overview, 315
- paravirtualized devices, 331
- ring buffer, 327–329
- VA-backed virtual machines, 336–340
- VDEVs (virtual devices), 326–327
- VID driver and memory manager, 317
- VID.sys (Virtual Infrastructure Driver), 317
- virtual IDE controller, 330
- VM (virtual machine), 318–322
- VM manager service and worker processes, 315–316
- VM Worker process, 318–322, 330
- VMBus, 323–329
- VMMEM process, 339–340
- Vmms.exe (virtual machine manager service), 315–316
- VM (View Manager), 244
- VMENTER event, 268
- VMEXIT event, 268, 330–331
- \VmSharedMemory directory, 161
- VMXROOT mode, 268
- volumes. *See also* tiered volumes
 - caching and file systems, 565–566
 - defined, 565–566
 - NTFS on-disk structure, 655
 - setting repair options, 706
- VSM (Virtual Secure Mode)
 - overview, 340–344
 - startup policy, 813–816
 - system calls, 349–355
- VTLs (virtual trust levels), 340–342

W

- wait block states, 186
- wait data structures, 189
- Wait for a single object service, 136
- Wait for multiple objects service, 136
- wait queues, 190–194
- WaitCompletionPacket object, 130
- wall time, 57
- Wbemtest command, 491

- Wcifs (Windows Container Isolation minifilter driver), 248
- Wcnfs (Windows Container Name Virtualization minifilter driver), 248
- WDK (Windows Driver Kit), 392
- WER (Windows Error Reporting)
 - ALPC (advanced local procedure call), 209
 - AeDebug and AeDebugProtected root keys, 540
 - crash dump files, 543–548
 - crash dump generation, 548–551
 - crash report generation, 538–542
 - dialog box, 541
 - Fault Reporting process, 540
 - implementation, 536
 - kernel reports, 551
 - kernel-mode (system) crashes, 543–551
 - overview, 535–537
 - process hang detection, 551–553
 - registry settings, 539–540
 - snapshot creation, 538
 - user application crashes, 537–542
 - user interface, 542
- Windows 10 Creators Update (RS2), 571
- Windows API, executive objects, 128–130
- Windows Bind minifilter driver, (BindFit) 248
- Windows Boot Manager, 785–799
 - BCD objects, 798
- \Windows directory, 161
- Windows hypervisor. *See also* Hyper-V schedulers
 - address space isolation, 282–285
 - AM (Address Manager), 275, 277
 - architectural stack, 268
 - on ARM64, 313–314
 - boot virtual processor, 277–279
 - child partitions, 269–270, 323
 - dynamic memory, 285–287
 - emulation of VT-x virtualization extensions, 309–310
 - enlightenments, 272

Windows hypervisor

- Windows hypervisor (*continued*)
 - execution vulnerabilities, 282
 - Hyperclear mitigation, 283
 - intercepts, 300–301
 - memory manager, 279–287
 - nested address translation, 310–313
 - nested virtualization, 307–313
 - overview, 267–268
 - partitions, processes, threads, 269–273
 - partitions physical address space, 281–282
 - PFN database, 286
 - platform API and EXO partitions, 304–305
 - private address spaces/memory zones, 284
 - process data structure, 271
 - processes and threads, 271
 - root partition, 270, 277–279
 - SLAT table, 281–282
 - startup, 274–279
 - SynIC (synthetic interrupt controller), 301–304
 - thread data structure, 271
 - VAL (VMX virtualization abstraction layer), 274, 279
 - VID driver, 272
 - virtual processor, 278
 - VM (Virtualization Manager), 278
 - VM_VP data structure, 278
 - VTIs (virtual trust levels), 281
- Windows hypervisor loader (Hvloader), BCD options, 796–797
- Windows loader issues, troubleshooting, 556–557
- Windows Memory Diagnostic Tool, 845
- Windows OS Loader, 792–796, 808–810
- Windows PowerShell, 774
- Windows services
 - accounts, 433–446
 - applications, 426–433
 - autostart startup, 451–457
 - boot and last known good, 460–462
 - characteristics, 429–433
 - Clipboard User Service, 472
 - control programs, 450–451
 - delayed autostart, 457–458
 - failures, 462–463
 - groupings, 466
 - interactive services/session 0 isolation, 444–446
 - local service account, 436
 - local system account, 434–435
 - network service account, 435
 - packaged services, 473
 - process, 428
 - protected services, 474–475
 - Recovery options, 463
 - running services, 436
 - running with least privilege, 437–439
 - SCM (Service Control Manager), 426, 446–450
 - SCP (service control program), 426
 - Service and Driver Registry parameters, 429–432
 - service isolation, 439–443
 - Service SIDs, 440–441
 - shared processes, 465–468
 - shutdown, 464–465
 - startup errors, 459–460
 - Svchost service splitting, 467–468
 - tags, 468–469
 - triggered-start, 457–459
 - user services, 469–473
 - virtual service account, 443–444
 - window stations, 445
- Windows threads, viewing user start address for, 89–91. *See also* thread-local register effect
- WindowStation object, 129
- Wininit, 831–835
- Winload, 792–796, 808–810
- Winlogon, 831–834, 838
- WinObjEx64 tool, 125
- WinRE (Windows Recovery Environment), 845–846. *See also* recovery

- WMI (Windows Management Instrumentation)
 - architecture, 487–488
 - CIM (Common Information Model), 488–495
 - class association, 493–494
 - Control Properties, 498
 - DMTF, 486, 489
 - implementation, 496–497
 - Managed Object Format Language, 489–495
 - MOF (Managed Object Format), 488–495
 - namespace, 493
 - ODBC (Open Database Connectivity), 488
 - overview, 486–487
 - providers, 488–489, 497
 - scripts to manage systems, 495
 - security, 498
 - System Control commands, 497
 - WmiGuid object, 130
 - WmiPrvSE creation, viewing, 496
 - WNF (Windows Notification Facility)
 - event aggregation, 237–238
 - features, 224–225
 - publishing and subscription model, 236–237
 - state names and storage, 233–237
 - users, 226–232
 - WNF state names, dumping, 237
 - wnfdump command, 237
 - WnfDump utility, 226, 237
 - WoW64 (Windows-on-Windows)
 - ARM, 113–114
 - ARM32 simulation on ARM 64 platforms, 115
 - core, 106–109
 - debugging in ARM64, 122–124
 - exception dispatching, 113
 - file system redirection, 109–110
 - memory models, 114
 - overview, 104–106
 - registry redirection, 110–111
 - system calls, 112
 - user-mode core, 108–109
 - X86 simulation on AMD64 platforms, 759–751
 - X86 simulation on ARM64 platforms, 115–125
 - write throttling, 596–597
 - write-back caching and lazy writing, 589–595
 - write-behind and read-ahead. *See* read-ahead and write-behind
 - WSL (Windows Subsystem for Linux), 64, 128
- ## X
- x64 systems, 2–4
 - viewing GDT on, 4–5
 - viewing TSS and IST on, 8–9
 - x86 simulation in ARM64 platforms, 115–124
 - x86 systems, 3, 35, 94–95, 101–102
 - exceptions and interrupt numbers, 86
 - Retpoline code sequence, 23
 - viewing GDT on, 5
 - viewing TSSs on, 7–8
 - XML descriptor, Task Scheduler, 479–481
 - XPERF tool, 504
 - XTA cache, 118–120