

vSphere Availability

Update 3

VMware vSphere 7.0

VMware ESXi 7.0

vCenter Server 7.0

You can find the most up-to-date technical documentation on the VMware website at:

<https://docs.vmware.com/>

VMware, Inc.
3401 Hillview Ave.
Palo Alto, CA 94304
www.vmware.com

Copyright © 2009-2021 VMware, Inc. All rights reserved. [Copyright and trademark information.](#)

Contents

About vSphere Availability 6

- 1 Business Continuity and Minimizing Downtime 7**
 - Reducing Planned Downtime 7
 - Preventing Unplanned Downtime 8
 - vSphere HA Provides Rapid Recovery from Outages 8
 - vSphere Fault Tolerance Provides Continuous Availability 10
 - Protecting vCenter Server with vCenter High Availability 10
 - Protecting vCenter Server with VMware Service Lifecycle Manager 10

- 2 Creating and Using vSphere HA Clusters 11**
 - How vSphere HA Works 11
 - Primary and Secondary Hosts 12
 - Host Failure Types 13
 - Determining Responses to Host Issues 14
 - VM and Application Monitoring 16
 - VM Component Protection 18
 - Network Partitions 19
 - Datastore Heartbeating 19
 - vSphere HA Security 20
 - vSphere HA Admission Control 21
 - Cluster Resources Percentage Admission Control 22
 - Slot Policy Admission Control 24
 - Dedicated Failover Hosts Admission Control 27
 - vSphere HA Interoperability 27
 - Using vSphere HA with vSAN 27
 - Using vSphere HA and DRS Together 29
 - Other vSphere HA Interoperability Issues 30
 - Creating a vSphere HA Cluster 31
 - vSphere HA Checklist 31
 - Create a vSphere HA Cluster in the vSphere Client 32
 - Configuring vSphere Availability Settings 34
 - Configuring Responses to Failures 34
 - Configure Proactive HA 37
 - Configure Admission Control 38
 - Configure Heartbeat Datastores 39
 - Set Advanced Options 40
 - Best Practices for VMware vSphere® High Availability Clusters 44

- Best Practices for Networking 44
- Best Practices for Interoperability 46
- Best Practices for Cluster Monitoring 47
- Change in behavior for HA VIBs 48

3 Providing Fault Tolerance for Virtual Machines 49

- How Fault Tolerance Works 49
- Fault Tolerance Use Cases 50
- Fault Tolerance Requirements, Limits, and Licensing 51
- Fault Tolerance Interoperability 52
 - vSphere Features not Supported with Fault Tolerance 52
 - Features and Devices Incompatible with Fault Tolerance 53
 - Using Fault Tolerance with DRS 53
- Preparing Your Cluster and Hosts for Fault Tolerance 54
 - Fault Tolerance Checklist 54
 - Configure Networking for Host Machines 56
 - Create Cluster and Check Compliance 56
- Using Fault Tolerance 57
 - Validation Checks for Turning On Fault Tolerance 57
 - Turn On Fault Tolerance 58
 - Turn Off Fault Tolerance 59
 - Suspend Fault Tolerance 60
 - Migrate Secondary 60
 - Test Failover 61
 - Test Restart Secondary 61
 - Upgrade Hosts Used for Fault Tolerance 61
- Enable Fault Tolerance Encryption 62
- Best Practices for Fault Tolerance 63
- Legacy Fault Tolerance 65
- Troubleshooting Fault Tolerant Virtual Machines 65
 - Hardware Virtualization Not Enabled 66
 - Compatible Hosts Not Available for Secondary VM 66
 - Secondary VM on Overcommitted Host Degrades Performance of Primary VM 67
 - Increased Network Latency Observed in FT Virtual Machines 67
 - Some Hosts Are Overloaded with FT Virtual Machines 68
 - Losing Access to FT Metadata Datastore 68
 - Turning On vSphere FT for Powered-On VM Fails 69
 - FT Virtual Machines not Placed or Evacuated by vSphere DRS 69
 - Fault Tolerant Virtual Machine Failovers 70

4 vCenter High Availability 72

Plan the vCenter HA Deployment	73
vCenter Architecture Overview	73
vCenter HA Hardware and Software Requirements	74
Configuration Workflow Overview in the vSphere Client	75
Configure the Network	76
Configure vCenter HA With the vSphere Client	77
Manage the vCenter HA Configuration	79
Set Up SNMP Traps	80
Set Up Your Environment to Use Custom Certificates	81
Manage vCenter HA SSH Keys	81
Initiate a vCenter HA Failover	82
Edit the vCenter HA Cluster Configuration	82
Perform Backup and Restore Operations	84
Remove a vCenter HA Configuration	84
Reboot All vCenter HA Nodes	85
Change the Server Environment	85
Collecting Support Bundles for a vCenter HA Node	85
Troubleshoot Your vCenter HA Environment	86
vCenter HA Clone Operation Fails During Deployment	86
Redeploy the Passive or Witness node	87
vCenter HA Deployment Fails with an Error	88
Troubleshooting a Degraded vCenter HA Cluster	88
Recovering from Isolated vCenter HA Nodes	89
Resolving Failover Failures	90
VMware vCenter® HA Alarms and Events	91
Patching a vCenter High Availability Environment	92

About vSphere Availability

vSphere Availability describes solutions that provide business continuity, including how to establish vSphere[®] High Availability (HA) and vSphere Fault Tolerance.

At VMware, we value inclusion. To foster this principle within our customer, partner, and internal community, we create content using inclusive language.

Intended Audience

This information is for anyone who wants to provide business continuity through the vSphere HA and Fault Tolerance solutions. The information in this book is for experienced Windows or Linux system administrators who are familiar with virtual machine technology and data center operations.

Business Continuity and Minimizing Downtime

1

Downtime, whether planned or unplanned, brings considerable costs. However, solutions that ensure higher levels of availability have traditionally been costly, hard to implement, and difficult to manage.

VMware software makes it simpler and less expensive to provide higher levels of availability for important applications. With vSphere, you can increase the baseline level of availability provided for all applications and provide higher levels of availability more easily and cost effectively. With vSphere, you can:

- Provide high availability independent of hardware, operating system, and applications.
- Reduce the planned downtime for common maintenance operations.
- Provide automatic recovery in cases of failure.

vSphere makes it possible to reduce planned downtime, prevent unplanned downtime, and recover rapidly from outages.

This chapter includes the following topics:

- [Reducing Planned Downtime](#)
- [Preventing Unplanned Downtime](#)
- [vSphere HA Provides Rapid Recovery from Outages](#)
- [vSphere Fault Tolerance Provides Continuous Availability](#)
- [Protecting vCenter Server with vCenter High Availability](#)
- [Protecting vCenter Server with VMware Service Lifecycle Manager](#)

Reducing Planned Downtime

Planned downtime typically accounts for over 80% of data center downtime. Hardware maintenance, server migration, and firmware updates all require downtime for physical servers. To minimize the impact of this downtime, organizations are forced to delay maintenance until inconvenient and difficult-to-schedule downtime windows.

vSphere makes it possible for organizations to dramatically reduce planned downtime. Because workloads in a vSphere environment can be dynamically moved to different physical servers without downtime or service interruption, server maintenance can be performed without requiring application and service downtime. With vSphere, organizations can:

- Eliminate downtime for common maintenance operations.
- Eliminate planned maintenance windows.
- Perform maintenance at any time without disrupting users and services.

The vSphere vMotion[®] and Storage vMotion functionality in vSphere makes it possible for organizations to reduce planned downtime because workloads in a VMware environment can be dynamically moved to different physical servers or to different underlying storage without service interruption. Administrators can perform faster and completely transparent maintenance operations, without being forced to schedule inconvenient maintenance windows.

Preventing Unplanned Downtime

While an ESXi host provides a robust platform for running applications, an organization must also protect itself from unplanned downtime caused from hardware or application failures. vSphere builds important capabilities into data center infrastructure that can help you prevent unplanned downtime.

These vSphere capabilities are part of virtual infrastructure and are transparent to the operating system and applications running in virtual machines. These features can be configured and utilized by all the virtual machines on a physical system, reducing the cost and complexity of providing higher availability. Key availability capabilities are built into vSphere:

- Shared storage. Eliminate single points of failure by storing virtual machine files on shared storage, such as Fibre Channel or iSCSI SAN, or NAS. The use of SAN mirroring and replication features can be used to keep updated copies of virtual disk at disaster recovery sites.
- Network interface teaming. Provide tolerance of individual network card failures.
- Storage multipathing. Tolerate storage path failures.

In addition to these capabilities, the vSphere HA and Fault Tolerance features can minimize or eliminate unplanned downtime by providing rapid recovery from outages and continuous availability, respectively.

vSphere HA Provides Rapid Recovery from Outages

vSphere HA leverages multiple ESXi hosts configured as a cluster to provide rapid recovery from outages and cost-effective high availability for applications running in virtual machines.

vSphere HA protects application availability in the following ways:

- It protects against a server failure by restarting the virtual machines on other hosts within the cluster.

- It protects against application failure by continuously monitoring a virtual machine and resetting it in the event that a failure is detected.
- It protects against datastore accessibility failures by restarting affected virtual machines on other hosts which still have access to their datastores.
- It protects virtual machines against network isolation by restarting them if their host becomes isolated on the management or vSAN network. This protection is provided even if the network has become partitioned.

Unlike other clustering solutions, vSphere HA provides the infrastructure to protect all workloads with the infrastructure:

- You do not need to install special software within the application or virtual machine. All workloads are protected by vSphere HA. After vSphere HA is configured, no actions are required to protect new virtual machines. They are automatically protected.
- You can combine vSphere HA with vSphere Distributed Resource Scheduler (DRS) to protect against failures and to provide load balancing across the hosts within a cluster.

vSphere HA has several advantages over traditional failover solutions:

Minimal setup

After a vSphere HA cluster is set up, all virtual machines in the cluster get failover support without additional configuration.

Reduced hardware cost and setup

The virtual machine acts as a portable container for the applications and it can be moved among hosts. Administrators avoid duplicate configurations on multiple machines. When you use vSphere HA, you must have sufficient resources to fail over the number of hosts you want to protect with vSphere HA. However, the VMware vCenter Server® system automatically manages resources and configures clusters.

Increased application availability

Any application running inside a virtual machine has access to increased availability. Because the virtual machine can recover from hardware failure, all applications that start at boot have increased availability without increased computing needs, even if the application is not itself a clustered application. By monitoring and responding to VMware Tools heartbeats and restarting nonresponsive virtual machines, it protects against guest operating system crashes.

DRS and vMotion integration

If a host fails and virtual machines are restarted on other hosts, DRS can provide migration recommendations or migrate virtual machines for balanced resource allocation. If one or both of the source and destination hosts of a migration fail, vSphere HA can help recover from that failure.

vSphere Fault Tolerance Provides Continuous Availability

vSphere HA provides a base level of protection for your virtual machines by restarting virtual machines in the event of a host failure. vSphere Fault Tolerance provides a higher level of availability, allowing users to protect any virtual machine from a host failure with no loss of data, transactions, or connections.

Fault Tolerance provides continuous availability by ensuring that the states of the Primary and Secondary VMs are identical at any point in the instruction execution of the virtual machine.

If either the host running the Primary VM or the host running the Secondary VM fails, an immediate and transparent failover occurs. The functioning ESXi host seamlessly becomes the Primary VM host without losing network connections or in-progress transactions. With transparent failover, there is no data loss and network connections are maintained. After a transparent failover occurs, a new Secondary VM is respawned and redundancy is re-established. The entire process is transparent and fully automated and occurs even if vCenter Server is unavailable.

Protecting vCenter Server with vCenter High Availability

vCenter High Availability (vCenter HA) protects not only against host and hardware failures but also against vCenter Server application failures. Using automated failover from active to passive, vCenter HA supports high availability with minimal downtime.

You configure vCenter HA from the vSphere Client. The configuration wizard provides these options.

Option	Description
Automatic	<p>The automatic option clones the Active node to the Passive node and witness node, and configures the nodes for you.</p> <p>If your environment meets the following requirements, you can use this option.</p> <ul style="list-style-type: none"> ■ The vCenter Server that becomes the Active node is managing its own ESXi host and its own virtual machine. This configuration is sometimes called a self-managed vCenter Server.
Manual	<p>The manual option offers more flexibility. You can use this option provided that your environment meets hardware and software requirements.</p> <p>If you select this option, you are responsible for cloning the Active node to the Passive node and the Witness node. You must also perform some networking configuration.</p>

Protecting vCenter Server with VMware Service Lifecycle Manager

Availability of vCenter Server is provided by VMware Service Lifecycle Manager.

If a vCenter service fails, VMware Service Lifecycle Manager restarts it. VMware Service Lifecycle Manager monitors the health of services and it takes preconfigured remediation action when it detects a failure. Service does not restart if multiple attempts to remediate fail.

Creating and Using vSphere HA Clusters

2

vSphere HA clusters enable a collection of ESXi hosts to work together so that, as a group, they provide higher levels of availability for virtual machines than each ESXi host can provide individually. When you plan the creation and usage of a new vSphere HA cluster, the options you select affect the way that cluster responds to failures of hosts or virtual machines.

Before you create a vSphere HA cluster, you should know how vSphere HA identifies host failures and isolation and how it responds to these situations. You also should know how admission control works so that you can choose the policy that fits your failover needs. After you establish a cluster, you can customize its behavior with advanced options and optimize its performance by following recommended best practices.

Note You might get an error message when you try to use vSphere HA. For information about error messages related to vSphere HA, see the VMware knowledge base article at <http://kb.vmware.com/kb/1033634>.

This chapter includes the following topics:

- [How vSphere HA Works](#)
- [vSphere HA Admission Control](#)
- [vSphere HA Interoperability](#)
- [Creating a vSphere HA Cluster](#)
- [Configuring vSphere Availability Settings](#)
- [Best Practices for VMware vSphere® High Availability Clusters](#)
- [Change in behavior for HA VIBs](#)

How vSphere HA Works

vSphere HA provides high availability for virtual machines by pooling the virtual machines and the hosts they reside on into a cluster. Hosts in the cluster are monitored and in the event of a failure, the virtual machines on a failed host are restarted on alternate hosts.

When you create a vSphere HA cluster, a single host is automatically elected as the primary host. The primary host communicates with vCenter Server and monitors the state of all protected virtual machines and of the secondary hosts. Different types of host failures are possible, and the primary host must detect and appropriately deal with the failure. The primary host must distinguish between a failed host and one that is in a network partition or that has become network isolated. The primary host uses network and datastore heartbeating to determine the type of failure.



Sphere HA Clusters

(<http://link.brightcove.com/services/player/bcpid2296383276001?bctid=ref:vSphereHAClusters>)

Primary and Secondary Hosts

When you add a host to a vSphere HA cluster, an agent is uploaded to the host and configured to communicate with other agents in the cluster. Each host in the cluster functions as a primary host or a secondary host.

When vSphere HA is enabled for a cluster, all active hosts (that are not in standby, maintenance mode or not disconnected) participate in an election to choose the cluster's primary host. The host that mounts the greatest number of datastores has an advantage in the election. Only one primary host typically exists per cluster and all other hosts are secondary hosts. If the primary host fails, is shut down or put in standby mode, or is removed from the cluster a new election is held.

The primary host in a cluster has several responsibilities:

- Monitoring the state of secondary hosts. If a secondary host fails or becomes unreachable, the primary host identifies which virtual machines must be restarted.
- Monitoring the power state of all protected virtual machines. If one virtual machine fails, the primary host ensures that it is restarted. Using a local placement engine, the primary host also determines where the restart takes place.
- Managing the lists of cluster hosts and protected virtual machines.
- Acting as the vCenter Server management interface to the cluster and reporting the cluster health state.

The secondary hosts primarily contribute to the cluster by running virtual machines locally, monitoring their runtime states, and reporting state updates to the primary host. A primary host can also run and monitor virtual machines. Both secondary hosts and primary hosts implement the VM and Application Monitoring features.

One of the functions performed by the primary host is to orchestrate restarts of protected virtual machines. A virtual machine is protected by a primary host after vCenter Server observes that the virtual machine's power state has changed from powered off to powered on in response to a user action. The primary host persists the list of protected virtual machines in the cluster's datastores. A newly elected primary host uses this information to determine which virtual machines to protect.

Note If you disconnect a host from a cluster, the virtual machines registered to that host are unprotected by vSphere HA.

Host Failure Types

The primary host of a VMware vSphere® High Availability cluster is responsible for detecting the failure of secondary hosts. Depending on the type of failure detected, the virtual machines running on the hosts might need to be failed over.

In a vSphere HA cluster, three types of host failure are detected:

- Failure. A host stops functioning.
- Isolation. A host becomes network isolated.
- Partition. A host loses network connectivity with the primary host.

The primary host monitors the liveness of the secondary hosts in the cluster. This communication happens through the exchange of network heartbeats every second. When the primary host stops receiving these heartbeats from a secondary host, it checks for host liveness before declaring the host failed. The liveness check that the primary host performs is to determine whether the secondary host is exchanging heartbeats with one of the datastores. See [Datastore Heartbeating](#) . Also, the primary host checks whether the host responds to ICMP pings sent to its management IP addresses.

If a primary host cannot communicate directly with the agent on a secondary host, the secondary host does not respond to ICMP pings. If the agent is not issuing heartbeats, it is viewed as failed. The host's virtual machines are restarted on alternate hosts. If such a secondary host is exchanging heartbeats with a datastore, the primary host assumes that the secondary host is in a network partition or is network isolated. So, the primary host continues to monitor the host and its virtual machines. See [Network Partitions](#) .

Host network isolation occurs when a host is still running, but it can no longer observe traffic from vSphere HA agents on the management network. If a host stops observing this traffic, it attempts to ping the cluster isolation addresses. If this pinging also fails, the host declares that it is isolated from the network.

The primary host monitors the virtual machines that are running on an isolated host. If the primary host observes that the VMs power off, and the primary host is responsible for the VMs, it restarts them.

Note If you ensure that the network infrastructure is sufficiently redundant and that at least one network path is always available, host network isolation is less likely to occur.

Proactive HA Failures

A Proactive HA failure occurs when a host component fails, which results in a loss of redundancy or a noncatastrophic failure. However, the functional behavior of the VMs residing on the host is not yet affected. For example, if a power supply on the host fails, but other power supplies are available, that is a Proactive HA failure.

If a Proactive HA failure occurs, you can automate the remediation action taken in the vSphere Availability section of the vSphere Client. The VMs on the affected host can be evacuated to other hosts and the host is either placed in Quarantine mode or Maintenance mode.

Note Your cluster must use vSphere DRS for the Proactive HA failure monitoring to work.

Determining Responses to Host Issues

If a host fails and its virtual machines must be restarted, you can control the order in which the virtual machines are restarted with the VM restart priority setting. You can also configure how vSphere HA responds if hosts lose management network connectivity with other hosts by using the host isolation response setting. Other factors are also considered when vSphere HA restarts a virtual machine after a failure.

The following settings apply to all virtual machines in the cluster in the case of a host failure or isolation. You can also configure exceptions for specific virtual machines. See [Customize an Individual Virtual Machine](#) .

Host Isolation Response

Host isolation response determines what happens when a host in a vSphere HA cluster loses its management network connections, but continues to run. You can use the isolation response to have vSphere HA power off virtual machines that are running on an isolated host and restart them on a non-isolated host. Host isolation responses require that Host Monitoring Status is enabled. If Host Monitoring Status is disabled, host isolation responses are also suspended. A host determines that it is isolated when it is unable to communicate with the agents running on the other hosts, and it is unable to ping its isolation addresses. The host then executes its isolation response. The responses are Power off and restart VMs or Shutdown and restart VMs. You can customize this property for individual virtual machines.

Note If a virtual machine has a restart priority setting of Disabled, no host isolation response is made.

To use the Shutdown and restart VMs setting, you must install VMware Tools in the guest operating system of the virtual machine. Shutting down the virtual machine provides the advantage of preserving its state. Shutting down is better than powering off the virtual machine, which does not flush most recent changes to disk or commit transactions. Virtual machines that are in the process of shutting down take longer to fail over while the shutdown completes. Virtual Machines that have not shut down in 300 seconds, or the time specified in the advanced option `das.isolationshutdowntimeout`, are powered off.

After you create a vSphere HA cluster, you can override the default cluster settings for Restart Priority and Isolation Response for specific virtual machines. Such overrides are useful for virtual machines that are used for special tasks. For example, virtual machines that provide infrastructure services like DNS or DHCP might need to be powered on before other virtual machines in the cluster.

A virtual machine "split-brain" condition can occur when a host becomes isolated or partitioned from a primary host and the primary host cannot communicate with it using heartbeat datastores. In this situation, the primary host cannot determine that the host is alive and so declares it dead. The primary host then attempts to restart the virtual machines that are running on the isolated or partitioned host. This attempt succeeds if the virtual machines remain running on the isolated/partitioned host and that host lost access to the virtual machines' datastores when it became isolated or partitioned. A split-brain condition then exists because there are two instances of the virtual machine. However, only one instance is able to read or write the virtual machine's virtual disks. VM Component Protection can be used to prevent this split-brain condition. When you enable VMCP with the aggressive setting, it monitors the datastore accessibility of powered-on virtual machines, and shuts down those that lose access to their datastores.

To recover from this situation, ESXi generates a question on the virtual machine that has lost the disk locks for when the host comes out of isolation and cannot reacquire the disk locks. vSphere HA automatically answers this question, allowing the virtual machine instance that has lost the disk locks to power off, leaving just the instance that has the disk locks.

Virtual Machine Dependencies

You can create dependencies between groups of virtual machines. To do so, you must first create the VM groups in the vSphere Client by going to the **Configure** tab for the cluster and selecting **VM/Host Groups**. Once the groups have been created, you can create restart dependency rules between the groups by browsing to **VM/Host Rules** and in the Type drop-down menu, select **Virtual Machines to Virtual Machines**. These rules can specify that certain VM groups cannot be restarted until other, specified VM groups have been Ready first.

Factors Considered for Virtual Machine Restarts

After a failure, the cluster's primary host attempts to restart affected virtual machines by identifying a host that can power them on. When choosing such a host, the primary host considers a number of factors.

File accessibility

Before a virtual machine can be started, its files must be accessible from one of the active cluster hosts that the primary can communicate with over the network

Virtual machine and host compatibility

If there are accessible hosts, the virtual machine must be compatible with at least one of them. The compatibility set for a virtual machine includes the effect of any required VM-Host affinity rules. For example, if a rule only permits a virtual machine to run on two hosts, it is considered for placement on those two hosts.

Resource reservations

Of the hosts that the virtual machine can run on, at least one must have sufficient unreserved capacity to meet the memory overhead of the virtual machine and any resource reservations. Four types of reservations are considered: CPU, Memory, vNIC, and Virtual flash. Also, sufficient network ports must be available to power on the virtual machine.

Host limits

In addition to resource reservations, a virtual machine can only be placed on a host if doing so does not violate the maximum number of allowed virtual machines or the number of in-use vCPUs.

Feature constraints

If the advanced option has been set that requires vSphere HA to enforce VM to VM anti-affinity rules, vSphere HA does not violate this rule. Also, vSphere HA does not violate any configured per host limits for fault tolerant virtual machines.

If no hosts satisfy the preceding considerations, the primary host issues an event stating that there are not enough resources for vSphere HA to start the VM and tries again when the cluster conditions have changed. For example, if the virtual machine is not accessible, the primary host tries again after a change in file accessibility.

VM and Application Monitoring

VM Monitoring restarts individual virtual machines if their VMware Tools heartbeats are not received within a set time. Similarly, Application Monitoring can restart a virtual machine if the heartbeats for an application it is running are not received. You can enable these features and configure the sensitivity with which vSphere HA monitors non-responsiveness.

When you enable VM Monitoring, the VM Monitoring service (using VMware Tools) evaluates whether each virtual machine in the cluster is running by checking for regular heartbeats and I/O activity from the VMware Tools process running inside the guest. If no heartbeats or I/O activity are received, this is most likely because the guest operating system has failed or VMware Tools is not being allocated any time to complete tasks. In such a case, the VM Monitoring service determines that the virtual machine has failed and the virtual machine is rebooted to restore service.

Occasionally, virtual machines or applications that are still functioning properly stop sending heartbeats. To avoid unnecessary resets, the VM Monitoring service also monitors a virtual machine's I/O activity. If no heartbeats are received within the failure interval, the I/O stats interval (a cluster-level attribute) is checked. The I/O stats interval determines if any disk or network activity has occurred for the virtual machine during the previous two minutes (120 seconds). If not, the virtual machine is reset. This default value (120 seconds) can be changed using the advanced option `das.iostatsinterval`.

To enable Application Monitoring, you must first obtain the appropriate SDK (or be using an application that supports VMware Application Monitoring) and use it to set up customized heartbeats for the applications you want to monitor. After you have done this, Application Monitoring works much the same way that VM Monitoring does. If the heartbeats for an application are not received for a specified time, its virtual machine is restarted.

You can configure the level of monitoring sensitivity. Highly sensitive monitoring results in a more rapid conclusion that a failure has occurred. While unlikely, highly sensitive monitoring might lead to falsely identifying failures when the virtual machine or application in question is actually still working, but heartbeats have not been received due to factors such as resource constraints. Low sensitivity monitoring results in longer interruptions in service between actual failures and virtual machines being reset. Select an option that is an effective compromise for your needs.

You can also specify custom values for both monitoring sensitivity and the I/O stats interval by selecting the **Custom** checkbox.

Table 2-1. VM Monitoring Settings

Setting	Failure Interval (seconds)	Reset Period
High	30	1 hour
Medium	60	24 hours
Low	120	7 days

After failures are detected, vSphere HA resets virtual machines. The reset ensures that services remain available. To avoid resetting virtual machines repeatedly for nontransient errors, by default, virtual machines will be reset only three times during a certain configurable time interval. After virtual machines have been reset three times, vSphere HA makes no further attempts to reset the virtual machines after subsequent failures until after the specified time has elapsed. You can configure the number of resets using the **Maximum per-VM resets** custom setting.

Note The reset statistics are cleared when a virtual machine is powered off then back on, or when it is migrated using vMotion to another host. This causes the guest operating system to reboot, but is not the same as a 'restart' in which the power state of the virtual machine is changed.

VM Component Protection

If VM Component Protection (VMCP) is enabled, vSphere HA can detect datastore accessibility failures and provide automated recovery for affected virtual machines.

VMCP provides protection against datastore accessibility failures that can affect a virtual machine running on a host in a vSphere HA cluster. When a datastore accessibility failure occurs, the affected host can no longer access the storage path for a specific datastore. You can determine the response that vSphere HA will make to such a failure, ranging from the creation of event alarms to virtual machine restarts on other hosts.

Note When you use the VM Component Protection feature, your ESXi hosts must be version 6.0 or higher.

Types of Failure

There are two types of datastore accessibility failure:

PDL

PDL (Permanent Device Loss) is an unrecoverable loss of accessibility that occurs when a storage device reports the datastore is no longer accessible by the host. This condition cannot be reverted without powering off virtual machines.

APD

APD (All Paths Down) represents a transient or unknown accessibility loss or any other unidentified delay in I/O processing. This type of accessibility issue is recoverable.

Configuring VMCP

VM Component Protection is configured in the vSphere Client. Go to the **Configure** tab and click **vSphere Availability** and **Edit**. Under **Failures and Responses** you can select **Datastore with PDL** or **Datastore with APD**. The storage protection levels you can choose and the virtual machine remediation actions available differ depending on the type of database accessibility failure.

PDL Failures

Under **Datastore with PDL**, you can select **Issue events** or **Power off and restart VMs**.

APD Failures

The response to APD events is more complex and accordingly the configuration is more fine-grained. You can select **Issue events**, **Power off and restart VMs--conservative restart policy**, or **Power off and restart VMs--aggressive restart policy**

Note If either the Host Monitoring or VM Restart Priority settings are disabled, VMCP cannot perform virtual machine restarts. Storage health can still be monitored and events can be issued, however.

Network Partitions

When a management network failure occurs for a vSphere HA cluster, a subset of the cluster's hosts might be unable to communicate over the management network with the other hosts. Multiple partitions can occur in a cluster.

A partitioned cluster leads to degraded virtual machine protection and cluster management functionality. Correct the partitioned cluster as soon as possible.

- Virtual machine protection. vCenter Server allows a virtual machine to be powered on, but it can be protected only if it is running in the same partition as the primary host that is responsible for it. The primary host must be communicating with vCenter Server. A primary host is responsible for a virtual machine if it has exclusively locked a system-defined file on the datastore that contains the virtual machine's configuration file.
- Cluster management. vCenter Server can communicate with the primary host, but only a subset of the secondary hosts. As a result, changes in configuration that affect vSphere HA might not take effect until after the partition is resolved. This failure could result in one of the partitions operating under the old configuration, while another uses the new settings.

Datastore Heartbeating

When the primary host in a VMware vSphere® High Availability cluster cannot communicate with a secondary host over the management network, the primary host uses datastore heartbeating to determine whether the secondary host has failed, is in a network partition, or is network isolated. If the secondary host has stopped datastore heartbeating, it is considered to have failed and its virtual machines are restarted elsewhere.

VMware vCenter Server® selects a preferred set of datastores for heartbeating. This selection is made to maximize the number of hosts that have access to a heartbeating datastore and minimize the likelihood that the datastores are backed by the same LUN or NFS server.

You can use the advanced option `das.heartbeatdsperhost` to change the number of heartbeat datastores selected by vCenter Server for each host. The default is two and the maximum valid value is five.

vSphere HA creates a directory at the root of each datastore that is used for both datastore heartbeating and for persisting the set of protected virtual machines. The name of the directory is `.vSphere-HA`. Do not delete or modify the files stored in this directory, because this can have an impact on operations. Because more than one cluster might use a datastore, subdirectories for this directory are created for each cluster. Root owns these directories and files and only root can read and write to them. The disk space used by vSphere HA depends on several factors including which VMFS version is in use and the number of hosts that use the datastore for heartbeating. With vmfs3, the maximum usage is 2GB and the typical usage is 3MB. With vmfs5, the maximum and typical usage is 3MB. vSphere HA use of the datastores adds negligible overhead and has no performance impact on other datastore operations.

vSphere HA limits the number of virtual machines that can have configuration files on a single datastore. See *Configuration Maximums* for updated limits. If you place more than this number of virtual machines on a datastore and power them on, vSphere HA protects virtual machines only up to the limit.

Note A vSAN datastore cannot be used for datastore heartbeating. Therefore, if no other shared storage is accessible to all hosts in the cluster, there can be no heartbeat datastores in use. However, if you have storage that is accessible by an alternate network path independent of the vSAN network, you can use it to set up a heartbeat datastore.

vSphere HA Security

vSphere HA is enhanced by several security features.

Select firewall ports opened

vSphere HA uses TCP and UDP port 8182 for agent-to-agent communication. The firewall ports open and close automatically to ensure they are open only when needed.

Configuration files protected using file system permissions

vSphere HA stores configuration information on the local storage or on ramdisk if there is no local datastore. These files are protected using file system permissions and they are accessible only to the root user. Hosts without local storage are only supported if they are managed by Auto Deploy.

Detailed logging

The location where vSphere HA places log files depends on the version of host.

- For ESXi 5.x hosts, vSphere HA writes to syslog only by default, so logs are placed where syslog is configured to put them. The log file names for vSphere HA are prepended with `fdm`, fault domain manager, which is a service of vSphere HA.
- For legacy ESXi 4.x hosts, vSphere HA writes to `/var/log/vmware/fdm` on local disk, as well as syslog if it is configured.
- For legacy ESX 4.x hosts, vSphere HA writes to `/var/log/vmware/fdm`.

Secure vSphere HA logins

vSphere HA logs onto the vSphere HA agents using a user account, **vpxuser**, created by vCenter Server. This account is the same account used by vCenter Server to manage the host. vCenter Server creates a random password for this account and changes the password periodically. The time period is set by the vCenter Server `VirtualCenter.VimPasswordExpirationInDays` setting. Users with administrative privileges on the root folder of the host can log in to the agent.

Secure communication

All communication between vCenter Server and the vSphere HA agent is done over SSL. Agent-to-agent communication also uses SSL except for election messages, which occur over UDP. Election messages are verified over SSL so that a rogue agent can prevent only the host on which the agent is running from being elected as a primary host. In this case, a configuration issue for the cluster is issued so the user is aware of the problem.

Host SSL certificate verification required

vSphere HA requires that each host have a verified SSL certificate. Each host generates a self-signed certificate when it is booted for the first time. This certificate can then be regenerated or replaced with one issued by an authority. If the certificate is replaced, vSphere HA needs to be reconfigured on the host. If a host becomes disconnected from vCenter Server after its certificate is updated and the ESXi or ESX Host agent is restarted, then vSphere HA is automatically reconfigured when the host is reconnected to vCenter Server. If the disconnection does not occur because vCenter Server host SSL certificate verification is disabled at the time, verify the new certificate and reconfigure vSphere HA on the host.

vSphere HA Admission Control

vSphere HA uses admission control to ensure that sufficient resources are reserved for virtual machine recovery when a host fails.

Admission control imposes constraints on resource usage. Any action that might violate these constraints is not permitted. Actions that might be disallowed include the following examples:

- Powering on a virtual machine
- Migrating a virtual machine
- Increasing the CPU or memory reservation of a virtual machine

The basis for vSphere HA admission control is how many host failures your cluster is allowed to tolerate and still guarantee failover. The host failover capacity can be set in three ways:

- Cluster resource percentage
- Slot policy
- Dedicated failover hosts

Note vSphere HA admission control can be disabled. However, without it you have no assurance that the expected number of virtual machines can be restarted after a failure. Do not permanently disable admission control.

Regardless of the admission control option chosen, a VM resource reduction threshold also exists. You use this setting to specify the percentage of resource degradation to tolerate, but it is not available unless vSphere DRS is enabled.

The resource reduction calculation is checked for both CPU and memory. It considers a virtual machine's reserved memory and memory overload to decide whether to permit it to power on, migrate, or have reservation changes. The actual memory consumed by the virtual machine is not considered in the calculation because the memory reservation does not always correlate with the actual memory usage of the virtual machine. If the actual usage is more than reserved memory, insufficient failover capacity is available, resulting in performance degradation on failover.

Setting a performance reduction threshold enables you to specify the occurrence of a configuration issue. For example:

- The default value is 100%, which produces no warnings.
- If you reduce the threshold to 0%, a warning is generated when cluster usage exceeds the available capacity.
- If you reduce the threshold to 20%, the performance reduction that can be tolerated is calculated as $\text{performance reduction} = \text{current utilization} * 20\%$. When the current usage minus the performance reduction exceeds the available capacity, a configuration notice is issued.

Cluster Resources Percentage Admission Control

You can configure vSphere HA to perform admission control by reserving a specific percentage of cluster CPU and memory resources for recovery from host failures.

With this type of admission control, vSphere HA ensures that a specified percentage of aggregate CPU and memory resources are reserved for failover.

With the cluster resources percentage option, vSphere HA enforces admission control as follows:

- 1 Calculates the total resource requirements for all powered-on virtual machines in the cluster.
- 2 Calculates the total host resources available for virtual machines.
- 3 Calculates the Current CPU Failover Capacity and Current Memory Failover Capacity for the cluster.
- 4 Determines if either the Current CPU Failover Capacity or Current Memory Failover Capacity is less than the corresponding Configured Failover Capacity (provided by the user).

If so, admission control disallows the operation.

vSphere HA uses the actual reservations of the virtual machines. If a virtual machine does not have reservations, meaning that the reservation is 0, a default of 0MB memory and 32MHz CPU is applied.

Note The cluster resources percentage option for admission control also checks that there are at least two vSphere HA-enabled hosts in the cluster (excluding hosts that are entering maintenance mode). If there is only one vSphere HA-enabled host, an operation is not allowed, even if there is a sufficient percentage of resources available. The reason for this extra check is that vSphere HA cannot perform failover if there is only a single host in the cluster.

Computing the Current Failover Capacity

The total resource requirements for the powered-on virtual machines is comprised of two components, CPU and memory. vSphere HA calculates these values.

- The CPU component by summing the CPU reservations of the powered-on virtual machines. If you have not specified a CPU reservation for a virtual machine, it is assigned a default value of 32MHz (this value can be changed using the `das.vmcPumInMHz` advanced option.)
- The memory component by summing the memory reservation (plus memory overhead) of each powered-on virtual machine.

The total host resources available for virtual machines is calculated by adding the hosts' CPU and memory resources. These amounts are those contained in the host's root resource pool, not the total physical resources of the host. Resources being used for virtualization purposes are not included. Only hosts that are connected, not in maintenance mode, and have no vSphere HA errors are considered.

The Current CPU Failover Capacity is computed by subtracting the total CPU resource requirements from the total host CPU resources and dividing the result by the total host CPU resources. The Current Memory Failover Capacity is calculated similarly.

Example: Admission Control Using Cluster Resources Percentage

The way that Current Failover Capacity is calculated and used with this admission control policy is shown with an example. Make the following assumptions about a cluster:

- The cluster is comprised of three hosts, each with a different amount of available CPU and memory resources. The first host (H1) has 9GHz of available CPU resources and 9GB of available memory, while Host 2 (H2) has 9GHz and 6GB and Host 3 (H3) has 6GHz and 6GB.
- There are five powered-on virtual machines in the cluster with differing CPU and memory requirements. VM1 needs 2GHz of CPU resources and 1GB of memory, while VM2 needs 2GHz and 1GB, VM3 needs 1GHz and 2GB, VM4 needs 1GHz and 1GB, and VM5 needs 1GHz and 1GB.
- The Configured Failover Capacity for CPU and Memory are both set to 25%.

Figure 2-1. Admission Control Example with Percentage of Cluster Resources Reserved Policy

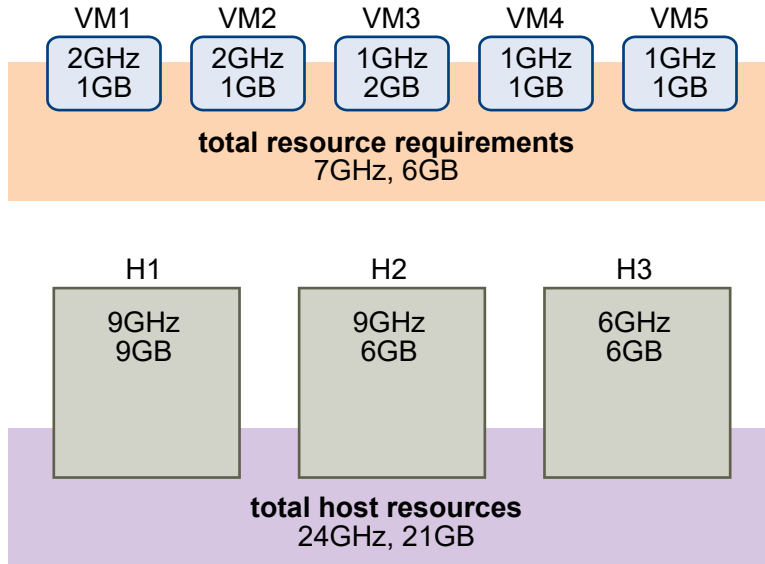

The total resource requirements for the powered-on virtual machines is 7GHz and 6GB. The total host resources available for virtual machines is 24GHz and 21GB. Based on this, the Current CPU Failover Capacity is 70% $((24\text{GHz} - 7\text{GHz})/24\text{GHz})$. Similarly, the Current Memory Failover Capacity is 71% $((21\text{GB} - 6\text{GB})/21\text{GB})$.

Because the cluster's Configured Failover Capacity is set to 25%, 45% of the cluster's total CPU resources and 46% of the cluster's memory resources are still available to power on additional virtual machines.

Slot Policy Admission Control

With the slot policy option, vSphere HA admission control ensures that a specified number of hosts can fail and sufficient resources remain in the cluster to fail over all the virtual machines from those hosts.

Using the slot policy, vSphere HA performs admission control in the following way:

- 1 Calculates the slot size.

A slot is a logical representation of memory and CPU resources. By default, it is sized to satisfy the requirements for any powered-on virtual machine in the cluster.

- 2 Determines how many slots each host in the cluster can hold.
- 3 Determines the Current Failover Capacity of the cluster.

This is the number of hosts that can fail and still leave enough slots to satisfy all of the powered-on virtual machines.

- 4 Determines whether the Current Failover Capacity is less than the Configured Failover Capacity (provided by the user).

If it is, admission control disallows the operation.

Note You can set a specific slot size for both CPU and memory in the admission control section of the vSphere HA settings in the vSphere Client.

Slot Size Calculation



vSphere HA Slot Size and Admission Control

(http://link.brightcove.com/services/player/bcpid2296383276001?bctid=ref:video_vsphere_slot_admission_control)

Slot size is comprised of two components, CPU and memory.

- vSphere HA calculates the CPU component by obtaining the CPU reservation of each powered-on virtual machine and selecting the largest value. If you have not specified a CPU reservation for a virtual machine, it is assigned a default value of 32MHz. You can change this value by using the `das.vmcpuminhz` advanced option.)
- vSphere HA calculates the memory component by obtaining the memory reservation, plus memory overhead, of each powered-on virtual machine and selecting the largest value. There is no default value for the memory reservation.

If your cluster contains any virtual machines that have much larger reservations than the others, they will distort slot size calculation. To avoid this, you can specify an upper bound for the CPU or memory component of the slot size by using the `das.slotcpuinhz` or `das.slotmeminhz` advanced options, respectively. See [vSphere HA Advanced Options](#).

You can also determine the risk of resource fragmentation in your cluster by viewing the number of virtual machines that require multiple slots. This can be calculated in the admission control section of the vSphere HA settings in the vSphere Client. Virtual machines might require multiple slots if you have specified a fixed slot size or a maximum slot size using advanced options.

Using Slots to Compute the Current Failover Capacity

After the slot size is calculated, vSphere HA determines each host's CPU and memory resources that are available for virtual machines. These amounts are those contained in the host's root resource pool, not the total physical resources of the host. The resource data for a host that is used by vSphere HA can be found on the host's **Summary** tab on the vSphere Client. If all hosts in your cluster are the same, this data can be obtained by dividing the cluster-level figures by the number of hosts. Resources being used for virtualization purposes are not included. Only hosts that are connected, not in maintenance mode, and that have no vSphere HA errors are considered.

The maximum number of slots that each host can support is then determined. To do this, the host's CPU resource amount is divided by the CPU component of the slot size and the result is rounded down. The same calculation is made for the host's memory resource amount. These two numbers are compared and the smaller number is the number of slots that the host can support.

The Current Failover Capacity is computed by determining how many hosts (starting from the largest) can fail and still leave enough slots to satisfy the requirements of all powered-on virtual machines.

Example: Admission Control Using Slot Policy

The way that slot size is calculated and used with this admission control policy is shown in an example. Make the following assumptions about a cluster:

- The cluster is comprised of three hosts, each with a different amount of available CPU and memory resources. The first host (H1) has 9GHz of available CPU resources and 9GB of available memory, while Host 2 (H2) has 9GHz and 6GB and Host 3 (H3) has 6GHz and 6GB.
- There are five powered-on virtual machines in the cluster with differing CPU and memory requirements. VM1 needs 2GHz of CPU resources and 1GB of memory, while VM2 needs 2GHz and 1GB, VM3 needs 1GHz and 2GB, VM4 needs 1GHz and 1GB, and VM5 needs 1GHz and 1GB.
- The Host Failures Cluster Tolerates is set to one.

Figure 2-2. Admission Control Example with Host Failures Cluster Tolerates Policy

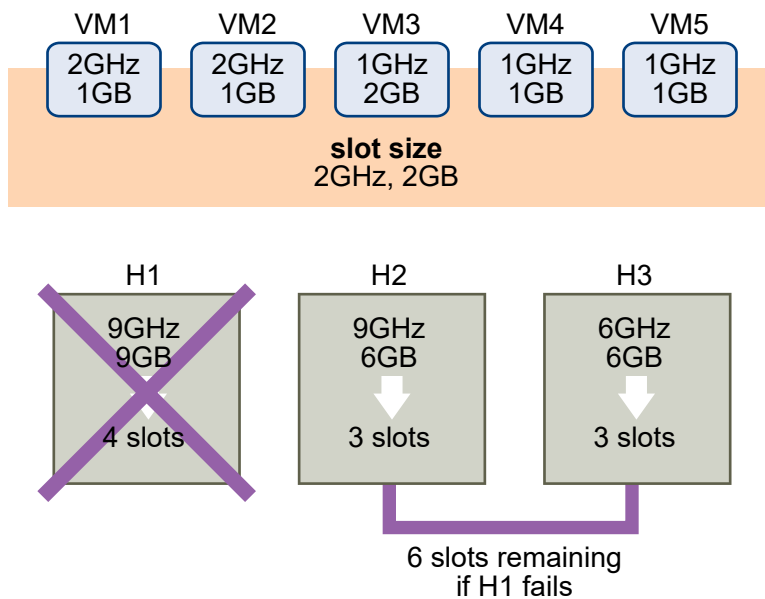

- 1 Slot size is calculated by comparing both the CPU and memory requirements of the virtual machines and selecting the largest.

The largest CPU requirement (shared by VM1 and VM2) is 2GHz, while the largest memory requirement (for VM3) is 2GB. Based on this, the slot size is 2GHz CPU and 2GB memory.

- 2 Maximum number of slots that each host can support is determined.

H1 can support four slots. H2 can support three slots (which is the smaller of 9GHz/2GHz and 6GB/2GB) and H3 can also support three slots.

- 3 Current Failover Capacity is computed.

The largest host is H1 and if it fails, six slots remain in the cluster, which is sufficient for all five of the powered-on virtual machines. If both H1 and H2 fail, only three slots remain, which is insufficient. Therefore, the Current Failover Capacity is one.

The cluster has one available slot (the six slots on H2 and H3 minus the five used slots).

Dedicated Failover Hosts Admission Control

You can configure vSphere HA to designate specific hosts as the failover hosts.

With dedicated failover hosts admission control, when a host fails, vSphere HA attempts to restart its virtual machines on any of the specified failover hosts. If restarting the virtual machines is not possible, for example the failover hosts have failed or have insufficient resources, then vSphere HA attempts to restart those virtual machines on other hosts in the cluster.

To ensure that spare capacity is available on a failover host, you are prevented from powering on virtual machines or using vMotion to migrate virtual machines to a failover host. Also, DRS does not use a failover host for load balancing.

Note If you use dedicated failover hosts admission control and designate multiple failover hosts, DRS does not attempt to enforce VM-VM affinity rules for virtual machines that are running on failover hosts.

vSphere HA Interoperability

vSphere HA can interoperate with many other features, such as DRS and vSAN.

Before configuring vSphere HA, you should be aware of the limitations of its interoperability with these other features or products.

Using vSphere HA with vSAN

You can use vSAN as the shared storage for a vSphere HA cluster. If enabled, vSAN aggregates the specified local storage disks available on the hosts into a single datastore shared by all hosts.

To use vSphere HA with vSAN, you must be aware of certain considerations and limitations for the interoperability of these two features.

For information about vSAN, see *Administering VMware vSAN*.

Note You can use vSphere HA with vSAN stretched clusters.

ESXi Host Requirements

You can use vSAN with a vSphere HA cluster only if the following conditions are met:

- All the cluster's ESXi hosts must be version 5.5 or later.
- The cluster must have a minimum of three ESXi hosts.

Networking Differences

vSAN has its own network. If vSAN and vSphere HA are enabled for the same cluster, the HA interagent traffic flows over this storage network rather than the management network. vSphere HA uses the management network only if vSAN is disabled. vCenter Server chooses the appropriate network if vSphere HA is configured on a host.

Note You can enable vSAN only if vSphere HA is disabled.

If you change the vSAN network configuration, the vSphere HA agents do not automatically pick up the new network settings. To make changes to the vSAN network, you must take the following steps in the vSphere Client:

- 1 Disable Host Monitoring for the vSphere HA cluster.
- 2 Make the vSAN network changes.
- 3 Right-click all hosts in the cluster and select **Reconfigure for vSphere HA**.
- 4 Re-enable Host Monitoring for the vSphere HA cluster.

Table 2-2. [vSphere HA Networking Differences](#) shows the differences in vSphere HA networking whether or not vSAN is used.

Table 2-2. vSphere HA Networking Differences

	vSAN Enabled	vSAN Disabled
Network used by vSphere HA	vSAN storage network	Management network
Heartbeat datastores	Any datastore mounted to > 1 host, but not vSAN datastores	Any datastore mounted to > 1 host
Host declared isolated	Isolation addresses not pingable and vSAN storage network inaccessible	Isolation addresses not pingable and management network inaccessible

Capacity Reservation Settings

When you reserve capacity for your vSphere HA cluster with an admission control policy, you must coordinate this setting with the corresponding vSAN setting that ensures data accessibility on failures. Specifically, the Number of Failures Tolerated setting in the vSAN rule set must not be lower than the capacity that the vSphere HA admission control setting reserved.

For example, if the vSAN rule set allows for only two failures, the vSphere HA admission control policy must reserve capacity that is equivalent to only one or two host failures. If you are using the Percentage of Cluster Resources Reserved policy for a cluster that has eight hosts, you must not reserve more than 25% of the cluster resources. In the same cluster, with the Host Failures Cluster Tolerates policy, the setting must not be higher than two hosts. If vSphere HA reserves less capacity, failover activity might be unpredictable. Reserving too much capacity overly constrains the powering on of virtual machines and intercluster vSphere vMotion migrations.

Using vSphere HA and DRS Together

Using vSphere HA with Distributed Resource Scheduler (DRS) combines automatic failover with load balancing. This combination can result in a more balanced cluster after vSphere HA has moved virtual machines to different hosts.

When vSphere HA performs failover and restarts virtual machines on different hosts, its first priority is the immediate availability of all virtual machines. After the virtual machines have been restarted, those hosts on which they were powered on might be heavily loaded, while other hosts are comparatively lightly loaded. vSphere HA uses the virtual machine's CPU and memory reservation and overhead memory to determine if a host has enough spare capacity to accommodate the virtual machine.

In a cluster using DRS and vSphere HA with admission control turned on, virtual machines might not be evacuated from hosts entering maintenance mode. This behavior occurs because of the resources reserved for restarting virtual machines in the event of a failure. You must manually migrate the virtual machines off of the hosts using vMotion.

In some scenarios, vSphere HA might not be able to fail over virtual machines because of resource constraints. This can occur for several reasons.

- HA admission control is disabled and Distributed Power Management (DPM) is enabled. This can result in DPM consolidating virtual machines onto fewer hosts and placing the empty hosts in standby mode leaving insufficient powered-on capacity to perform a failover.
- VM-Host affinity (required) rules might limit the hosts on which certain virtual machines can be placed.
- There might be sufficient aggregate resources but these can be fragmented across multiple hosts so that they can not be used by virtual machines for failover.

In such cases, vSphere HA can use DRS to try to adjust the cluster (for example, by bringing hosts out of standby mode or migrating virtual machines to defragment the cluster resources) so that HA can perform the failovers.

If DPM is in manual mode, you might need to confirm host power-on recommendations. Similarly, if DRS is in manual mode, you might need to confirm migration recommendations.

If you are using VM-Host affinity rules that are required, be aware that these rules cannot be violated. vSphere HA does not perform a failover if doing so would violate such a rule.

For more information about DRS, see the *vSphere Resource Management* documentation.

Note vSphere DRS is a critical feature of vSphere which is required to maintain the health of the workloads running inside vSphere Cluster. Starting with vSphere 7.0 Update 1, DRS depends on the availability of vCLS VMs. See *vSphere Cluster Services (vCLS)* in *vSphere Resource Management* for more information.

vSphere HA and DRS Affinity Rules

If you create a DRS affinity rule for your cluster, you can specify how vSphere HA applies that rule during a virtual machine failover.

The two types of rules for which you can specify vSphere HA failover behavior are the following:

- VM anti-affinity rules force specified virtual machines to remain apart during failover actions.
- VM-Host affinity rules place specified virtual machines on a particular host or a member of a defined group of hosts during failover actions.

When you edit a DRS affinity rule, you must use vSphere HA advanced options to enforce the desired failover behavior for vSphere HA.

- **HA must respect VM anti-affinity rules during failover** -- When the advanced option for VM anti-affinity rules is set, vSphere HA does not fail over a virtual machine if doing so violates a rule. Instead, vSphere HA issues an event reporting there are insufficient resources to perform the failover.
- **HA should respect VM to Host affinity rules during failover** --vSphere HA attempts to place VMs with this rule on the specified hosts if at all possible.

For more information, see vSphere HA Advanced Options.

Note vSphere HA can restart a VM in a DRS-disabled cluster, overriding a VM-Host affinity rules mapping if the host failure happens soon (by default, within 5 minutes) after setting the rule.

Other vSphere HA Interoperability Issues

To use vSphere HA, you must be aware of the following additional interoperability issues.

VM Component Protection

VM Component Protection (VMCP) has the following interoperability issues and limitations:

- VMCP does not support vSphere Fault Tolerance. If VMCP is enabled for a cluster using Fault Tolerance, the affected FT virtual machines will automatically receive overrides that disable VMCP.
- VMCP does not detect or respond to accessibility issues for files located on vSAN datastores. If a virtual machine's configuration and VMDK files are located only on vSAN datastores, they are not protected by VMCP.
- VMCP does not detect or respond to accessibility issues for files located on Virtual Volume datastores. If a virtual machine's configuration and VMDK files are located only on Virtual Volume datastores, they are not protected by VMCP.
- VMCP does not protect against inaccessible Raw Device Mapping (RDM)s.

IPv6

vSphere HA can be used with IPv6 network configurations, which are fully supported if the following considerations are observed:

- The cluster contains only ESXi 6.0 or later hosts.
- The management network for all hosts in the cluster must be configured with the same IP version, either IPv6 or IPv4. vSphere HA clusters cannot contain both types of networking configuration.
- The network isolation addresses used by vSphere HA must match the IP version used by the cluster for its management network.
- IPv6 cannot be used in vSphere HA clusters that also utilize vSAN.

In addition to the previous restrictions, the following types of IPv6 address types are not supported for use with the vSphere HA isolation address or management network: link-local, ORCHID, and link-local with zone indices. Also, the loopback address type cannot be used for the management network.

Note To upgrade an existing IPv4 deployment to IPv6, you must first disable vSphere HA.

Creating a vSphere HA Cluster

vSphere HA operates in the context of a cluster of ESXi (or legacy ESX) hosts. You must create a cluster, populate it with hosts, and configure vSphere HA settings before failover protection can be established.

When you create a vSphere HA cluster, you must configure a number of settings that determine how the feature works. Before you do this, identify your cluster's nodes. These nodes are the ESXi hosts that will provide the resources to support virtual machines and that vSphere HA will use for failover protection. You should then determine how those nodes are to be connected to one another and to the shared storage where your virtual machine data resides. After that networking architecture is in place, you can add the hosts to the cluster and finish configuring vSphere HA.

You can enable and configure vSphere HA before you add host nodes to the cluster. However, until the hosts are added, your cluster is not fully operational and some of the cluster settings are unavailable. For example, the Specify a Failover Host admission control policy is unavailable until there is a host that can be designated as the failover host.

Note The Virtual Machine Startup and Shutdown (automatic startup) feature is disabled for all virtual machines residing on hosts that are in (or moved into) a vSphere HA cluster. Automatic startup is not supported when used with vSphere HA.

vSphere HA Checklist

The vSphere HA checklist contains requirements that you must be aware of before creating and using a vSphere HA cluster.

Review this list before you set up a vSphere HA cluster. For more information, follow the appropriate cross reference.

- All hosts must be licensed for vSphere HA.
- A cluster must contain at least two hosts.
- All hosts must be configured with static IP addresses. If you are using DHCP, you must ensure that the address for each host persists across reboots.
- All hosts must have at least one management network in common. The best practice is to have at least two management networks in common. You should use the VMkernel network with the **Management traffic** checkbox enabled. The networks must be accessible to each other and vCenter Server and the hosts must be accessible to each other on the management networks. See [Best Practices for Networking](#).
- To ensure that any virtual machine can run on any host in the cluster, all hosts must have access to the same virtual machine networks and datastores. Similarly, virtual machines must be located on shared, not local, storage otherwise they cannot be failed over in the case of a host failure.

Note vSphere HA uses datastore heartbeating to distinguish between partitioned, isolated, and failed hosts. So if some datastores are more reliable in your environment, configure vSphere HA to give preference to them.

- For VM Monitoring to work, VMware tools must be installed. See [VM and Application Monitoring](#).
- vSphere HA supports both IPv4 and IPv6. See [Other vSphere HA Interoperability Issues](#) for considerations when using IPv6.
- For VM Component Protection to work, hosts must have the All Paths Down (APD) Timeout feature enabled.
- To use VM Component Protection, clusters must contain ESXi 6.0 hosts or later.
- Only vSphere HA clusters that contain ESXi 6.0 or later hosts can be used to enable VMCP. Clusters that contain hosts from an earlier release cannot enable VMCP, and such hosts cannot be added to a VMCP-enabled cluster.
- If your cluster uses Virtual Volume datastores, when vSphere HA is enabled a configuration Virtual Volume is created on each datastore by vCenter Server. In these containers, vSphere HA stores the files it uses to protect virtual machines. vSphere HA does not function correctly if you delete these containers. Only one container is created per Virtual Volume datastore.

Create a vSphere HA Cluster in the vSphere Client

To enable your cluster for vSphere HA, you must first create an empty cluster. After you plan the resources and networking architecture of your cluster, use the vSphere Client to add hosts to the cluster and specify the cluster's vSphere HA settings.

A vSphere HA-enabled cluster is a prerequisite for vSphere Fault Tolerance.

Prerequisites

- Verify that all virtual machines and their configuration files reside on shared storage.
- Verify that the hosts are configured to access the shared storage so that you can power on the virtual machines by using different hosts in the cluster.
- Verify that hosts are configured to have access to the virtual machine network.
- Verify that you are using redundant management network connections for vSphere HA. For information about setting up network redundancy, see [Best Practices for Networking](#).
- Verify that you have configured hosts with at least two datastores to provide redundancy for vSphere HA datastore heartbeating.
- Connect vSphere Client to vCenter Server by using an account with cluster administrator permissions.

Procedure

- 1 In the vSphere Client, browse to the data center where you want the cluster to reside and click **New Cluster**.
- 2 Complete the **New Cluster** wizard.
Do not turn on vSphere HA (or DRS).
- 3 Click **OK** to close the wizard and create an empty cluster.
- 4 Based on your plan for the resources and networking architecture of the cluster, use the vSphere Client to add hosts to the cluster.
- 5 Browse to the cluster and enable vSphere HA.
 - a Click the **Configure** tab.
 - b Select **vSphere Availability** and click **Edit**.
 - c Select **vSphere HA**.
- 6 Under **Failures and Responses** select **Enable Host Monitoring**.
With Host Monitoring enabled, hosts in the cluster can exchange network heartbeats and vSphere HA can take action when it detects failures. Host Monitoring is required for the vSphere Fault Tolerance recovery process to work properly.
- 7 Select a setting for **VM Monitoring**.
Select **VM Monitoring Only** to restart individual virtual machines if their heartbeats are not received within a set time. You can also select **VM and Application Monitoring** to enable application monitoring.
- 8 Click **OK**.

Results

You have a vSphere HA cluster, populated with hosts.

What to do next

Configure the appropriate vSphere HA settings for your cluster.

- Failures and responses
- Admission Control
- Heartbeat Datastores
- Advanced Options

See [Configuring vSphere Availability Settings](#).

Configuring vSphere Availability Settings

When you create a vSphere HA cluster or configure an existing cluster, you must configure settings that determine how the feature works.

In the vSphere Client, you can configure following the vSphere HA settings:

Failures and responses

Provide settings here for host failure responses, host isolation, VM monitoring, and VM Component Protection.

Admission Control

Enable or disable admission control for the vSphere HA cluster and choose a policy for how it is enforced.

Heartbeat Datastores

Specify preferences for the datastores that vSphere HA uses for datastore heartbeating.

Advanced Options

Customize vSphere HA behavior by setting advanced options.

Configuring Responses to Failures

The **Failure and Responses** pane of the vSphere HA settings allows you to configure how your cluster should function when problems are encountered.

In this part of the vSphere Client, you can determine the specific responses the vSphere HA cluster has for host failures and isolation. You can also configure VM Component Protection (VMCP) actions when Permanent Device Loss (PDL) and All Paths Down (APD) situations occur and you can enable VM monitoring.

The following tasks are available:

Procedure

1 [Respond to Host Failure](#)

You can set specific responses to host failures that occur in your vSphere HA cluster.

2 Respond to Host Isolation

You can set specific responses to host isolation that occurs in your vSphere HA cluster.

3 Configure VMCP Responses

Configure the response that VM Component Protection (VMCP) makes when a datastore encounters a PDL or APD failure.

4 Enable VM Monitoring

You can turn on VM and Application Monitoring and also set the monitoring sensitivity for your vSphere HA cluster.

Respond to Host Failure

You can set specific responses to host failures that occur in your vSphere HA cluster.

This page is editable only if you have enabled vSphere HA.

Procedure

- 1 In the vSphere Client, browse to the vSphere HA cluster.
- 2 Click the **Configure** tab.
- 3 Select **vSphere Availability** and click **Edit**.
- 4 Click **Failures and Responses** and then expand **Host Failure Response**.
- 5 Select from the following configuration options.

Option	Description
Failure Response	If you select Disabled , this setting turns off host monitoring and VMs are not restarted when host failures occur. If Restart VMs is selected, VMs are failed over based on their restart priority when a host fails.
Default VM Restart Priority	The restart priority determines the order in which virtual machines are restarted when the host fails. Higher priority virtual machines are started first. If multiple hosts fail, all virtual machines are migrated from the first host in order of priority, then all virtual machines from the second host in order of priority, and so on.
VM Restart Priority Condition	A specific condition must be selected as well as a delay after that condition has been met, before vSphere HA is allowed to continue to the next VM restart priority.

- 6 Click **OK**.

Results

Your settings for the host failure response take effect.

Respond to Host Isolation

You can set specific responses to host isolation that occurs in your vSphere HA cluster.

This page is editable only if you have enabled vSphere HA.

Procedure

- 1 In the vSphere Client, browse to the vSphere HA cluster.
- 2 Click the **Configure** tab.
- 3 Select **vSphere Availability** and click **Edit**.
- 4 Click **Failures and Responses** and expand **Response for Host Isolation**.
- 5 To configure the host isolation response, select **Disabled**, **Shut down and restart VMs**, or **Power off and restart VMs**.
- 6 Click **OK**.

Results

Your setting for the host isolation response takes effect.

Configure VMCP Responses

Configure the response that VM Component Protection (VMCP) makes when a datastore encounters a PDL or APD failure.

This page is editable only if you have enabled vSphere HA.

Procedure

- 1 In the vSphere Client, browse to the vSphere HA cluster.
- 2 Click the **Configure** tab.
- 3 Select **vSphere Availability** and click **Edit**.
- 4 Click **Failures and Responses**, and expand either **Datastore with PDL** or **Datastore with APD**.
- 5 If you clicked **Datastore with PDL**, you can set the VMCP failure response for this type of issue, either **Disabled**, **Issue Events**, or **Power off and restart VMs**.
- 6 If you clicked **Datastore with APD**, you can set the VMCP failure response for this type of issue, either **Disabled**, **Issue Events**, **Power off and restart VMs--Conservative restart policy**, or **Power off and restart VMs--Aggressive restart policy**. You can also set **Response recovery**, which is the number of minutes that VMCP waits before taking action.
- 7 Click **OK**.

Results

Your settings for the VMCP failure response take effect.

Enable VM Monitoring

You can turn on VM and Application Monitoring and also set the monitoring sensitivity for your vSphere HA cluster.

This page is editable only if you have enabled vSphere HA.

Procedure

- 1 In the vSphere Client, browse to the vSphere HA cluster.
- 2 Click the **Configure** tab.
- 3 Select **vSphere Availability** and click **Edit**.
- 4 Click **Failures and Responses** and expand **VM Monitoring**.
- 5 Select **VM Monitoring** and **Application Monitoring**.
These settings turn on VMware Tools heartbeats and application heartbeats, respectively.
- 6 To set the heartbeat monitoring sensitivity, move the slider between **Low** and **High** or select **Custom** to provide custom settings.
- 7 Click **OK**.

Results

Your monitoring settings take effect.

Configure Proactive HA

You can configure how Proactive HA responds when a provider has notified its health degradation to vCenter, indicating a partial failure of that host.

This page is editable only if you have enabled vSphere DRS.

Procedure

- 1 In the vSphere Client, browse to the Proactive HA cluster.
- 2 Click the **Configure** tab.
- 3 Select **vSphere Availability** and click **Edit**.
- 4 Select **Turn on Proactive HA**.
- 5 Click **Proactive HA Failures and Responses**.

6 Select from the following configuration options.

Option	Description
Automation Level	<p>Determine whether host quarantine or maintenance mode and VM migrations are recommendations or automatic.</p> <ul style="list-style-type: none"> ■ Manual. vCenter Server suggests migration recommendations for virtual machines. ■ Automated. Virtual machines are migrated to healthy hosts and degraded hosts are entered into quarantine or maintenance mode depending on the configured Proactive HA automation level.
Remediation	<p>Determine what happens to partially degraded hosts.</p> <ul style="list-style-type: none"> ■ Quarantine mode for all failures. Balances performance and availability, by avoiding the usage of partially degraded hosts provided that virtual machine performance is unaffected. ■ Quarantine mode for moderate and Maintenance mode for severe failure (Mixed). Balances performance and availability, by avoiding the usage of moderately degraded hosts provided that virtual machine performance is unaffected. Ensures that virtual machines do not run on severely failed hosts. ■ Maintenance mode for all failures. Ensures that virtual machines do not run on partially failed hosts. <p><code>Host.Config.Quarantine</code> and <code>Host.Config.Maintenance</code> privileges are required to put hosts in Quarantine mode and Maintenance mode, respectively.</p>

To enable Proactive HA providers for this cluster, select the check boxes. Providers appear when their corresponding vSphere Client plugin has been installed and the providers monitor every host in the cluster. To view or edit the failure conditions supported by the provider, click the edit link.

7 Click **OK**.

Configure Admission Control

After you create a cluster, you can configure admission control to specify whether virtual machines can be started if they violate availability constraints. The cluster reserves resources so that failover can occur for all running virtual machines on the specified number of hosts.

The Admission Control page appears only if you enabled vSphere HA.

Procedure

- 1 In the vSphere Client, browse to the vSphere HA cluster.
- 2 Click the **Configure** tab.
- 3 Select **vSphere Availability** and click **Edit**.
- 4 Click **Admission Control** to display the configuration options.
- 5 Select a number for the **Host failures cluster tolerates**. This is the maximum number of host failures that the cluster can recover from or guarantees failover for.

6 Select an option for **Define host failover capacity by**.

Option	Description
Cluster resource percentage	Specify a percentage of the cluster's CPU and memory resources to reserve as spare capacity to support failovers.
Slot Policy (powered-on VMs)	Select a slot size policy that covers all powered on VMs or is a fixed size. You can also calculate how many VMs require multiple slots.
Dedicated failover hosts	Select hosts to use for failover actions. Failovers can still occur on other hosts in the cluster if a default failover host does not have enough resources.
Disabled	Select this option to disable admission control and allow virtual machine power ons that violate availability constraints.

7 Set the percentage for the **Performance degradation VMs tolerate**.

This setting determines what percentage of performance degradation the VMs in the cluster are allowed to tolerate during a failure.

8 Click **OK**.

Results

Your admission control settings take effect.

Configure Heartbeat Datastores

vSphere HA uses datastore heartbeating to distinguish between hosts that have failed and hosts that reside on a network partition. With datastore heartbeating, vSphere HA can monitor hosts when a management network partition occurs and continue to respond to failures.

You can specify the datastores that you want to be used for datastore heartbeating.

Procedure

- 1 In the vSphere Client, browse to the vSphere HA cluster.
- 2 Click the **Configure** tab.
- 3 Select **vSphere Availability** and click **Edit**.
- 4 Click **Heartbeat Datastores** to display the configuration options for datastore heartbeating.

- To instruct vSphere HA about how to select the datastores and how to treat your preferences, select from the following options.

Table 2-3.

Datastore Heartbeating Options
Automatically select datastores accessible from the host
Use datastores only from the specified list
Use datastores from the specified list and complement automatically if needed

- In the Available heartbeat datastores pane, select the datastores that you want to use for heartbeating.

The listed datastores are shared by more than one host in the vSphere HA cluster. When a datastore is selected, the lower pane displays all the hosts in the vSphere HA cluster that can access it.

- Click **OK**.

Set Advanced Options

To customize vSphere HA behavior, set advanced vSphere HA options.

Prerequisites

Verify that you have cluster administrator privileges.

Note Because these options affect the functioning of vSphere HA, change them with caution.

Procedure

- In the vSphere Client, browse to the vSphere HA cluster.
- Click the **Configure** tab.
- Select **vSphere Availability** and click **Edit**.
- Click **Advanced Options**.
- Click **Add** and type the name of the advanced option in the text box.
You can set the value of the option in the text box in the Value column.
- Repeat step 5 for each new option that you want to add and click **OK**.

Results

The cluster uses the options that you added or modified.

What to do next

Once you have set an advanced vSphere HA option, it persists until you do one the following:

- Using the vSphere Client, reset its value to the default value.

- Manually edit or delete the option from the `fdm.cfg` file on all hosts in the cluster.

vSphere HA Advanced Options

You can set advanced options that affect the behavior of your vSphere HA cluster.

Table 2-4. vSphere HA Advanced Options

Option	Description
<code>das.isolationaddress[...]</code>	Sets the address to ping to determine if a host is isolated from the network. This address is pinged only when heartbeats are not received from any other host in the cluster. If not specified, the default gateway of the management network is used. This default gateway has to be a reliable address that is available, so that the host can determine if it is isolated from the network. You can specify multiple isolation addresses (up to 10) for the cluster: <code>das.isolationAddressX</code> , where X = 0-9. Typically you should specify one per management network. Specifying too many addresses makes isolation detection take too long.
<code>das.usedefaultisolationaddress</code>	By default, vSphere HA uses the default gateway of the console network as an isolation address. This option specifies whether or not this default is used (<code>true/false</code>).
<code>das.isolationshutdowntimeout</code>	The period of time the system waits for a virtual machine to shut down before powering it off. This only applies if the host's isolation response is Shut down VM. Default value is 300 seconds.
<code>das.slotmeminmb</code>	Defines the maximum bound on the memory slot size. If this option is used, the slot size is the smaller of this value or the maximum memory reservation plus memory overhead of any powered-on virtual machine in the cluster.
<code>das.slotcpuinmhz</code>	Defines the maximum bound on the CPU slot size. If this option is used, the slot size is the smaller of this value or the maximum CPU reservation of any powered-on virtual machine in the cluster.
<code>das.vmmemoryminmb</code>	Defines the default memory resource value assigned to a virtual machine if its memory reservation is not specified or zero. This is used for the Host Failures Cluster Tolerates admission control policy. If no value is specified, the default is 0 MB.
<code>das.vmcpumminmhz</code>	Defines the default CPU resource value assigned to a virtual machine if its CPU reservation is not specified or zero. This is used for the Host Failures Cluster Tolerates admission control policy. If no value is specified, the default is 32MHz.

Table 2-4. vSphere HA Advanced Options (continued)

Option	Description
<code>das.iostatsinterval</code>	<p>Changes the default I/O stats interval for VM Monitoring sensitivity. The default is 120 (seconds). Can be set to any value greater than, or equal to 0. Setting to 0 disables the check.</p> <p>Note Values of less than 50 are not recommended since smaller values can result in vSphere HA unexpectedly resetting a virtual machine.</p>
<code>das.ignoreinsufficienthbdatastore</code>	<p>Disables configuration issues created if the host does not have sufficient heartbeat datastores for vSphere HA. Default value is false.</p>
<code>das.heartbeatdsperhost</code>	<p>Changes the number of heartbeat datastores required. Valid values can range from 2-5 and the default is 2.</p>
<code>das.config.fdm.isolationPolicyDelaySec</code>	<p>The number of seconds system waits before executing the isolation policy once it is determined that a host is isolated. The minimum value is 30. If set to a value less than 30, the delay will be 30 seconds.</p>
<code>das.respectvmvantiAffinityrules</code>	<p>Determines if vSphere HA enforces VM-VM anti-affinity rules. The default value is "true" and rules are enforced even if vSphere DRS is not enabled. In this case, vSphere HA does not fail over a virtual machine if doing so violates a rule, but it issues an event reporting there are insufficient resources to perform the failover. This option can also be set to "false", whereby the rules are not enforced.</p> <p>See <i>vSphere Resource Management</i> for more information on anti-affinity rules.</p>
<code>das.maxresets</code>	<p>The maximum number of reset attempts made by VMCP. If a reset operation on a virtual machine affected by an APD situation fails, VMCP retries the reset this many times before giving up</p>
<code>das.maxterminates</code>	<p>The maximum number of retries made by VMCP for virtual machine termination.</p>
<code>das.terminateretryintervalsec</code>	<p>If VMCP fails to terminate a virtual machine, this is the number of seconds the system waits before it retries a terminate attempt</p>
<code>das.config.fdm.reportfailoverfailevent</code>	<p>When set to 1, enables generation of a detailed per-VM event when an attempt by vSphere HA to restart a virtual machine is unsuccessful. Default value is 0. In versions earlier than vSphere 6.0, this event is generated by default.</p>
<code>vpzd.das.completemetadataupdateintervalsec</code>	<p>The period of time (seconds) after a VM-Host affinity rule is set during which vSphere HA can restart a VM in a DRS-disabled cluster, overriding the rule. Default value is 300 seconds.</p>

Table 2-4. vSphere HA Advanced Options (continued)

Option	Description
<code>das.config.fdm.memReservationMB</code>	<p>By default vSphere HA agents run with a configured memory limit of 250 MB. A host might not allow this reservation if it runs out of reservable capacity. You can use this advanced option to lower the memory limit to avoid this issue. Only integers greater than 100, which is the minimum value, can be specified. Conversely, to prevent problems during primary agent elections in a large cluster (containing 6,000 to 8,000 VMs) you should raise this limit to 325 MB.</p> <p>Note Once this limit is changed, for all hosts in the cluster you must run the Reconfigure HA task. Also, when a new host is added to the cluster or an existing host is rebooted, this task should be performed on those hosts in order to update this memory setting.</p>
<code>das.reregisterrestartdisabledvms</code>	<p>When vSphere HA is disabled on a specific VM this option ensures that the VM is registered on another host after a failure. This allows you to power-on that VM without needing to re-register it manually.</p> <p>Note When this option is used, vSphere HA does not power on the VM, but only registers it.</p>
<code>das.respectvmhostsoftaffinityrules</code>	<p>Determines if vSphere HA restarts a respective VM on a host that belongs to the same VM-Host group. If no such host is available or if the value of this option is set to "false", vSphere HA restarts the VM on any available host in the cluster. In vSphere 6.5, the default value is "true". This value might not be visibly defined in the advanced HA options of the cluster. If you want to disable the option, you must manually set this option as "false" in the advanced HA options for the cluster.</p>

Note If you change the value of any of the following advanced options, you must disable and then re-enable vSphere HA before your changes take effect.

- `das.isolationaddress[...]`
- `das.usedefaultisolationaddress`
- `das.isolationshutdowntimeout`

Customize an Individual Virtual Machine

Each virtual machine in a vSphere HA cluster is assigned the cluster default settings for VM Restart Priority, Host Isolation Response, VM Component Protection, and VM Monitoring. You can specify specific behavior for each virtual machine by changing these defaults. If the virtual machine leaves the cluster, these settings are lost.

Procedure

- 1 In the vSphere Client, browse to the vSphere HA cluster.
- 2 Click the **Configure** tab.
- 3 Under Configuration, select **VM Overrides** and click **Add**.
- 4 Use the **+** button to select virtual machines to which to apply the overrides.
- 5 Click **OK**.
- 6 (Optional) You can change other settings, such as the **Automation level**, **VM restart priority**, **Response for Host Isolation**, VMCP settings, **VM Monitoring**, or **VM monitoring sensitivity** settings.

Note You can view the cluster defaults for these settings by first expanding **Relevant Cluster Settings** and then expanding **vSphere HA**.

- 7 Click **OK**.

Results

The virtual machine's behavior now differs from the cluster defaults for each setting that you changed.

Best Practices for VMware vSphere® High Availability Clusters

To ensure optimal vSphere HA cluster performance, you must follow certain best practices. This section highlights some of the key best practices for a vSphere HA cluster.

You can also refer to the *vSphere High Availability Deployment Best Practices* publication for further discussion.

Best Practices for Networking

Observe the following best practices for the configuration of host NICs and network topology for vSphere HA. Best Practices include recommendations for your ESXi hosts, and for cabling, switches, routers, and firewalls.

Network Configuration and Maintenance

The following network maintenance suggestions can help you avoid the accidental detection of failed hosts and network isolation because of dropped vSphere HA heartbeats.

- When changing the networks that your clustered ESXi hosts are on, suspend the Host Monitoring feature. Changing your network hardware or networking settings can interrupt the heartbeats that vSphere HA uses to detect host failures, which might result in unwanted attempts to fail over virtual machines.

- When you change the networking configuration on the ESXi hosts themselves, for example, adding port groups, or removing vSwitches, suspend Host Monitoring. After you have made the networking configuration changes, you must reconfigure vSphere HA on all hosts in the cluster, which causes the network information to be reinspected. Then re-enable Host Monitoring.

Note Because networking is a vital component of vSphere HA, if network maintenance must be performed inform the vSphere HA administrator.

Networks Used for vSphere HA Communications

To identify which network operations might disrupt the functioning of vSphere HA, you must know which management networks are being used for heart beating and other vSphere HA communications.

- On legacy ESX hosts in the cluster, vSphere HA communications travel over all networks that are designated as service console networks. VMkernel networks are not used by these hosts for vSphere HA communications. To contain vSphere HA traffic to a subset of the ESX console networks, use the `allowedNetworks` advanced option.
- On ESXi hosts in the cluster, vSphere HA communications, by default, travel over VMkernel networks. With an ESXi host, if you want to use a network other than the one vCenter Server uses to communicate with the host for vSphere HA, you must explicitly enable the **Management traffic** check box.

To keep vSphere HA agent traffic on the networks you have specified, configure hosts so vmkNICs used by vSphere HA do not share subnets with vmkNICs used for other purposes. vSphere HA agents send packets using any pNIC that is associated with a given subnet when there is also at least one vmkNIC configured for vSphere HA management traffic. Therefore, to ensure network flow separation, the vmkNICs used by vSphere HA and by other features must be on different subnets.

Network Isolation Addresses

A network isolation address is an IP address that is pinged to determine whether a host is isolated from the network. This address is pinged only when a host has stopped receiving heartbeats from all other hosts in the cluster. If a host can ping its network isolation address, the host is not network isolated, and the other hosts in the cluster have either failed or are network partitioned. However, if the host cannot ping its isolation address, it is likely that the host has become isolated from the network and no failover action is taken.

By default, the network isolation address is the default gateway for the host. Only one default gateway is specified, regardless of how many management networks have been defined. Use the `das.isolationaddress[...]` advanced option to add isolation addresses for additional networks. See [vSphere HA Advanced Options](#).

Network Path Redundancy

Network path redundancy between cluster nodes is important for vSphere HA reliability. A single management network ends up being a single point of failure and can result in failovers although only the network has failed. If you have only one management network, any failure between the host and the cluster can cause an unnecessary (or false) failover activity if heartbeat datastore connectivity is not retained during the networking failure. Possible failures include NIC failures, network cable failures, network cable removal, and switch resets. Consider these possible sources of failure between hosts and try to minimize them, typically by providing network redundancy.

The first way you can implement network redundancy is at the NIC level with NIC teaming. Using a team of two NICs connected to separate physical switches improves the reliability of a management network. Because servers connected through two NICs (and through separate switches) have two independent paths for sending and receiving heartbeats, the cluster is more resilient. To configure a NIC team for the management network, configure the vNICs in vSwitch configuration for Active or Standby configuration. The recommended parameter settings for the vNICs are:

- Default load balancing = route based on originating port ID
- Failback = No

After you have added a NIC to a host in your vSphere HA cluster, you must reconfigure vSphere HA on that host.

In most implementations, NIC teaming provides sufficient heartbeat redundancy, but as an alternative you can create a second management network connection attached to a separate virtual switch. Redundant management networking allows the reliable detection of failures and prevents isolation or partition conditions from occurring, because heartbeats can be sent over multiple networks. The original management network connection is used for network and management purposes. When the second management network connection is created, vSphere HA sends heartbeats over both management network connections. If one path fails, vSphere HA still sends and receives heartbeats over the other path.

Note Configure the fewest possible number of hardware segments between the servers in a cluster. The goal being to limit single points of failure. Also, routes with too many hops can cause networking packet delays for heartbeats, and increase the possible points of failure.

Using IPv6 Network Configurations

Only one IPv6 address can be assigned to a given network interface used by your vSphere HA cluster. Assigning multiple IP addresses increases the number of heartbeat messages sent by the cluster's primary host with no corresponding benefit.

Best Practices for Interoperability

Observe the following best practices for allowing interoperability between vSphere HA and other features.

vSphere HA and Storage vMotion Interoperability in a Mixed Cluster

In clusters where ESXi 5.x hosts and ESX/ESXi 4.1 or earlier hosts are present and where Storage vMotion is used extensively or Storage DRS is enabled, do not deploy vSphere HA. vSphere HA might respond to a host failure by restarting a virtual machine on a host with an ESXi version different from the one on which the virtual machine was running before the failure. A problem can occur if, at the time of failure, the virtual machine was involved in a Storage vMotion action on an ESXi 5.x host, and vSphere HA restarts the virtual machine on a host with a version earlier than ESXi 5.0. While the virtual machine might power-on, any subsequent attempts at snapshot operations might corrupt the vdisk state and leave the virtual machine unusable.

Using Auto Deploy with vSphere HA

You can use vSphere HA and Auto Deploy together to improve the availability of your virtual machines. Auto Deploy provisions hosts when they power-on and you can also configure it to install the vSphere HA agent on hosts during the boot process. See the Auto Deploy documentation included in vSphere Installation and Setup for details.

Upgrading Hosts in a Cluster Using vSAN

If you are upgrading the ESXi hosts in your vSphere HA cluster to version 5.5 or later, and you also plan to use vSAN, follow this process.

- 1 Upgrade all of the hosts.
- 2 Disable vSphere HA.
- 3 Enable vSAN.
- 4 Re-enable vSphere HA.

Best Practices for Cluster Monitoring

Observe the following best practices for monitoring the status and validity of your vSphere HA cluster.

Setting Alarms to Monitor Cluster Changes

When vSphere HA or Fault Tolerance take action to maintain availability, for example, a virtual machine failover, you can be notified about such changes. Configure alarms in vCenter Server to be triggered when these actions occur, and have alerts, such as emails, sent to a specified set of administrators.

Several default vSphere HA alarms are available.

- Insufficient failover resources (a cluster alarm)
- Cannot find primary (a cluster alarm)
- Failover in progress (a cluster alarm)
- Host HA status (a host alarm)
- VM monitoring error (a virtual machine alarm)

- VM monitoring action (a virtual machine alarm)
- Failover failed (a virtual machine alarm)

Note The default alarms include the feature name, vSphere HA.

Change in behavior for HA VIBs

In vSphere 7.0, it is possible the HA VIBs might be removed in some cases when HA is enabled on a Lifecycle Managed (vLCM) cluster. In previous releases, vCenter would not attempt to remove HA VIBs from ESXi hosts.

This situation can occur only on vLCM clusters with vSphere HA enabled. When a vLCM **Remediate** operation occurs (either as a user-initiated operation or an API invocation) after vSphere HA is disabled on the cluster, the vSphere HA VIBs might be removed as a consequence.

Note This change in behavior is harmless because vCenter pushes the required vSphere HA VIBs when HA is enabled again.

Providing Fault Tolerance for Virtual Machines

3

You can use vSphere Fault Tolerance for your virtual machines to ensure continuity with higher levels of availability and data protection.

Fault Tolerance is built on the ESXi host platform, and it provides availability by having identical virtual machines run on separate hosts.

To obtain the optimal results from Fault Tolerance you must be familiar with how it works, how to enable it for your cluster, virtual machines and the best practices for its usage.

This chapter includes the following topics:

- [How Fault Tolerance Works](#)
- [Fault Tolerance Use Cases](#)
- [Fault Tolerance Requirements, Limits, and Licensing](#)
- [Fault Tolerance Interoperability](#)
- [Preparing Your Cluster and Hosts for Fault Tolerance](#)
- [Using Fault Tolerance](#)
- [Enable Fault Tolerance Encryption](#)
- [Best Practices for Fault Tolerance](#)
- [Legacy Fault Tolerance](#)
- [Troubleshooting Fault Tolerant Virtual Machines](#)

How Fault Tolerance Works

You can use vSphere Fault Tolerance (FT) for most mission critical virtual machines. FT provides continuous availability for such a virtual machine by creating and maintaining another VM that is identical and continuously available to replace it in the event of a failover situation.

The protected virtual machine is called the Primary VM. The duplicate virtual machine, the Secondary VM, is created and runs on another host. The primary VM is continuously replicated to the secondary VM so that the secondary VM can take over at any point, thereby providing Fault Tolerant protection.

The Primary and Secondary VMs continuously monitor the status of one another to ensure that Fault Tolerance is maintained. A transparent failover occurs if the host running the Primary VM fails, or encounters an uncorrectable hardware error in the memory of the Primary VM, in which case the Secondary VM is immediately activated to replace the Primary VM. A new Secondary VM is started and Fault Tolerance redundancy is reestablished automatically. If the host running the Secondary VM fails, it is also immediately replaced. In either case, users experience no interruption in service and no loss of data.

A fault tolerant virtual machine and its secondary copy are not allowed to run on the same host. This restriction ensures that a host failure cannot result in the loss of both VMs.

Note You can also use VM-Host affinity rules to dictate which hosts designated virtual machines can run on. If you use these rules, be aware that for any Primary VM that is affected by such a rule, its associated Secondary VM is also affected by that rule. For more information about affinity rules, see the vSphere Resource Management documentation.

Fault Tolerance avoids "split-brain" situations, which can lead to two active copies of a virtual machine after recovery from a failure. Atomic file locking on shared storage is used to coordinate failover so that only one side continues running as the Primary VM and a new Secondary VM is respawned automatically.

vSphere Fault Tolerance can accommodate symmetric multiprocessor (SMP) virtual machines with up to four vCPUs.

Fault Tolerance Use Cases

Several typical situations can benefit from the use of vSphere Fault Tolerance.

Fault Tolerance provides a higher level of business continuity than vSphere HA. When a Secondary VM is called upon to replace its Primary VM counterpart, the Secondary VM immediately takes over the Primary VM's role with the entire state of the virtual machine preserved. Applications are already running, and data stored in memory does not need to be reentered or reloaded. Failover provided by vSphere HA restarts the virtual machines affected by a failure.

This higher level of continuity and the added protection of state information and data informs the scenarios when you might want to deploy Fault Tolerance.

- Applications which must always be available, especially applications that have long-lasting client connections that users want to maintain during hardware failure.
- Custom applications that have no other way of doing clustering.
- Cases where high availability might be provided through custom clustering solutions, which are too complicated to configure and maintain.

Another key use case for protecting a virtual machine with Fault Tolerance can be described as On-Demand Fault Tolerance. In this case, a virtual machine is adequately protected with vSphere HA during normal operation. During certain critical periods, you might want to enhance the protection of the virtual machine. For example, you might be running a quarter-end report which, if interrupted, might delay the availability of critical information. With vSphere Fault Tolerance, you can protect this virtual machine before running this report and then turn off or suspend Fault Tolerance after the report has been produced. You can use On-Demand Fault Tolerance to protect the virtual machine during a critical time period and return the resources to normal during non-critical operation.

Fault Tolerance Requirements, Limits, and Licensing

Before using vSphere Fault Tolerance (FT), consider the high-level requirements, limits, and licensing that apply to this feature.

Requirements

The following CPU and networking requirements apply to FT.

CPUs that are used in host machines for fault tolerant VMs must be compatible with vSphere vMotion. Also, CPUs that support Hardware MMU virtualization (Intel EPT or AMD RVI) are required. The following CPUs are supported.

- Intel Sandy Bridge or later. Avoton is not supported.
- AMD Bulldozer or later.

Use a 10-Gbit logging network for FT and verify that the network is low latency. A dedicated FT network is highly recommended.

Limits

In a cluster configured to use Fault Tolerance, two limits are enforced independently.

das.maxftvmsperhost

The maximum number of fault tolerant VMs allowed on a host in the cluster. The default value is 4. There is no FT VMs per host maximum, you can use larger numbers if the workload performs well in FT VMs. You can disable checking by setting the value to 0.

das.maxftvcpusperhost

The maximum number of vCPUs aggregated across all fault tolerant VMs on a host. The default value is 8. There is no FT vCPU per host maximum, you can use larger numbers if the workload performs well. You can disable checking by setting the value to 0.

Licensing

The number of vCPUs supported by a single fault tolerant VM is limited by the level of licensing that you have purchased for vSphere. Fault Tolerance is supported as follows:

- vSphere Standard and Enterprise. Allows up to 2 vCPUs
- vSphere Enterprise Plus. Allows up to 8 vCPUs

Note FT is supported in vSphere Standard, vSphere Enterprise and vSphere Enterprise Plus Editions.

Fault Tolerance Interoperability

Before configuring vSphere Fault Tolerance, you must be aware of the features and products Fault Tolerance cannot interoperate with.

vSphere Features Not Supported with Fault Tolerance

When configuring your cluster, you should be aware that not all vSphere features can interoperate with Fault Tolerance.

The following vSphere features are not supported for fault tolerant virtual machines.

- Snapshots. Snapshots must be removed or committed before Fault Tolerance can be enabled on a virtual machine. In addition, it is not possible to take snapshots of virtual machines on which Fault Tolerance is enabled.

Note Disk-only snapshots created for vStorage APIs - Data Protection (VADP) backups are supported with Fault Tolerance. However, legacy FT does not support VADP.

- Storage vMotion. You cannot invoke Storage vMotion for virtual machines with Fault Tolerance turned on. To migrate the storage, you should temporarily turn off Fault Tolerance, and perform the storage vMotion action. When this is complete, you can turn Fault Tolerance back on.
- Linked clones. You cannot use Fault Tolerance on a virtual machine that is a linked clone, nor can you create a linked clone from an FT-enabled virtual machine.
- Virtual Volume datastores.
- Storage-based policy management. Storage policies are supported for vSAN storage.
- I/O filters.
- Disk encryption.
- TPM.
- VBS enabled VMs.

Features and Devices Incompatible with Fault Tolerance

Not all third party devices, features, or products can interoperate with Fault Tolerance.

For a virtual machine to be compatible with Fault Tolerance, the Virtual Machine must not use the following features or devices.

Table 3-1. Features and Devices Incompatible with Fault Tolerance and Corrective Actions

Incompatible Feature or Device	Corrective Action
Physical Raw Disk mapping (RDM).	With legacy FT you can reconfigure virtual machines with physical RDM-backed virtual devices to use virtual RDMs instead.
CD-ROM or floppy virtual devices backed by a physical or remote device.	Remove the CD-ROM or floppy virtual device or reconfigure the backing with an ISO installed on shared storage.
USB and sound devices.	Remove these devices from the virtual machine.
N_Port ID Virtualization (NPIV).	Disable the NPIV configuration of the virtual machine.
NIC passthrough.	This feature is not supported by Fault Tolerance so it must be turned off.
Hot-plugging devices.	<p>The hot plug feature is automatically disabled for fault tolerant virtual machines. To hot plug devices (either adding or removing), you must momentarily turn off Fault Tolerance, perform the hot plug, and then turn on Fault Tolerance.</p> <p>Note When using Fault Tolerance, changing the settings of a virtual network card while a virtual machine is running is a hot-plug operation, since it requires "unplugging" the network card and then "plugging" it in again. For example, with a virtual network card for a running virtual machine, if you change the network that the virtual NIC is connected to, FT must be turned off first.</p>
Serial or parallel ports	Remove these devices from the virtual machine.
Video devices that have 3D enabled.	Fault Tolerance does not support video devices that have 3D enabled.
Virtual Machine Communication Interface (VMCI)	Not supported by Fault Tolerance.
2TB+ VMDK	Fault Tolerance is not supported with a 2TB+ VMDK.

Using Fault Tolerance with DRS

You can use vSphere Fault Tolerance with vSphere Distributed Resource Scheduler (DRS).

FT VMs do not require EVC to support DRS. You can use FT with DRS on vSphere 6.5 and 6.0 hosts that are managed by a vSphere 6.7 or higher VC.

Note vSphere DRS is a critical feature of vSphere which is required to maintain the health of the workloads running inside vSphere Cluster. Starting with vSphere 7.0 Update 1, DRS depends on the availability of vCLS VMs. See *vSphere Cluster Services (vCLS)* in *vSphere Resource Management* for more information.

Preparing Your Cluster and Hosts for Fault Tolerance

To enable vSphere Fault Tolerance for your cluster, you must meet the feature's prerequisites and you must perform certain configuration steps on your hosts. After those steps are accomplished and your cluster has been created, you can also check that your configuration complies with the requirements for enabling Fault Tolerance.

The tasks you should complete before attempting to set up Fault Tolerance for your cluster include the following:

- Ensure that your cluster, hosts, and virtual machines meet the requirements outlined in the Fault Tolerance checklist.
- Configure networking for each host.
- Create the vSphere HA cluster, add hosts, and check compliance.

After your cluster and hosts are prepared for Fault Tolerance, you are ready to turn on Fault Tolerance for your virtual machines. See [Turn On Fault Tolerance](#).

Fault Tolerance Checklist

The following checklist contains cluster, host, and virtual machine requirements that you need to be aware of before using vSphere Fault Tolerance.

Review this list before setting up Fault Tolerance.

Note The failover of fault tolerant virtual machines is independent of vCenter Server, but you must use vCenter Server to set up your Fault Tolerance clusters.

Cluster Requirements for Fault Tolerance

You must meet the following cluster requirements before you use Fault Tolerance.

- Fault Tolerance logging and VMotion networking configured. See [Configure Networking for Host Machines](#).
- vSphere HA cluster created and enabled. See [Creating a vSphere HA Cluster](#). vSphere HA must be enabled before you can power on fault tolerant virtual machines or add a host to a cluster that already supports fault tolerant virtual machines.

Host Requirements for Fault Tolerance

You must meet the following host requirements before you use Fault Tolerance.

- Hosts must use supported processors.
- Hosts must be licensed for Fault Tolerance.
- Hosts must be certified for Fault Tolerance. See <http://www.vmware.com/resources/compatibility/search.php> and select **Search by Fault Tolerant Compatible Sets** to determine if your hosts are certified.
- The configuration for each host must have Hardware Virtualization (HV) enabled in the BIOS.

Note VMware recommends that the hosts you use to support FT VMs have their BIOS power management settings turned to "Maximum performance" or "OS-managed performance".

To confirm the compatibility of the hosts in the cluster to support Fault Tolerance, you can also run profile compliance checks as described in [Create Cluster and Check Compliance](#).

Virtual Machine Requirements for Fault Tolerance

You must meet the following virtual machine requirements before you use Fault Tolerance.

- No unsupported devices attached to the virtual machine. See [Fault Tolerance Interoperability](#).
- Incompatible features must not be running with the fault tolerant virtual machines. See [Fault Tolerance Interoperability](#).
- Virtual machine files (except for the VMDK files) must be stored on shared storage. Acceptable shared storage solutions include Fibre Channel, (hardware and software) iSCSI, vSAN, NFS, and NAS.

Other Configuration Recommendations

You should also observe the following guidelines when configuring Fault Tolerance.

- If you are using NFS to access shared storage, use dedicated NAS hardware with at least a 1Gbit NIC to obtain the network performance required for Fault Tolerance to work properly.
- The memory reservation of a fault tolerant virtual machine is set to the VM's memory size when Fault Tolerance is turned on. Ensure that a resource pool containing fault tolerant VMs has memory resources above the memory size of the virtual machines. Without this excess in the resource pool, there might not be any memory available to use as overhead memory.
- To ensure redundancy and maximum Fault Tolerance protection, you should have a minimum of three hosts in the cluster. In a failover situation, this provides a host that can accommodate the new Secondary VM that is created.

Configure Networking for Host Machines

On each host that you want to add to a vSphere HA cluster, you must configure two different networking switches (vMotion and FT logging) so that the host can support vSphere Fault Tolerance.

To set up Fault Tolerance for a host, you must complete this procedure for each port group option (vMotion and FT logging) to ensure that sufficient bandwidth is available for Fault Tolerance logging. Select one option, finish this procedure, and repeat the procedure a second time, selecting the other port group option.

Prerequisites

Multiple gigabit Network Interface Cards (NICs) are required. For each host supporting Fault Tolerance, a minimum of two physical NICs is recommended. For example, you need one dedicated to Fault Tolerance logging and one dedicated to vMotion. Use three or more NICs to ensure availability.

Procedure

- 1 In the vSphere Client, browse to the host.
- 2 Click the **Configure** tab and click **Networking**.
- 3 Select **VMkernel adapters**.
- 4 Click the **Add Networking** icon.
- 5 Provide appropriate information for your connection type.
- 6 Click **Finish**.

Results

After you create both a vMotion and Fault Tolerance logging virtual switch, you can create other virtual switches, as needed. Add the host to the cluster and complete any steps needed to turn on Fault Tolerance.

What to do next

Note If you configure networking to support FT but subsequently suspend the Fault Tolerance logging port, pairs of fault tolerant virtual machines that are powered on remain powered on. If a failover situation occurs, when the Primary VM is replaced by its Secondary VM a new Secondary VM is not started, causing the new Primary VM to run in a Not Protected state.

Create Cluster and Check Compliance

vSphere Fault Tolerance is used in the context of a vSphere HA cluster. After you configure networking on each host, create the vSphere HA cluster and add the hosts to it. You can check to see whether the cluster is configured correctly and complies with the requirements for the enablement of Fault Tolerance.

Procedure

- 1 In the vSphere Client, browse to the cluster.
- 2 Click the **Monitor** tab and click **Profile Compliance**.
- 3 Click **Check Compliance Now** to run the compliance tests.

Results

The results of the compliance test appear, and the compliance or noncompliance of each host is shown.

Using Fault Tolerance

After you have taken all of the required steps for enabling vSphere Fault Tolerance for your cluster, you can use the feature by turning it on for individual virtual machines.

Before Fault Tolerance can be turned on, validation checks are performed on a virtual machine.

After these checks are passed and you turn on vSphere Fault Tolerance for a virtual machine, new options are added to the Fault Tolerance section of its context menu. These include turning off or disabling Fault Tolerance, migrating the Secondary VM, testing failover, and testing restart of the Secondary VM.

Validation Checks for Turning On Fault Tolerance

If the option to turn on Fault Tolerance is available, this task still must be validated and can fail if certain requirements are not met.

Several validation checks are performed on a virtual machine before Fault Tolerance can be turned on.

- SSL certificate checking must be enabled in the vCenter Server settings.
- The host must be in a vSphere HA cluster or a mixed vSphere HA and DRS cluster.
- The host must have ESXi 6.x or greater installed.
- The virtual machine must not have snapshots.
- The virtual machine must not be a template.
- The virtual machine must not have vSphere HA disabled.
- The virtual machine must not have a video device with 3D enabled.

Checks for Powered-On Virtual Machines

Several additional validation checks are performed for powered-on virtual machines (or those that are in the process of being powered on).

- The BIOS of the hosts where the fault tolerant virtual machines reside must have Hardware Virtualization (HV) enabled.

- The host that supports the Primary VM must have a processor that supports Fault Tolerance.
- Your hardware should be certified as compatible with Fault Tolerance. To confirm that it is, use the VMware Compatibility Guide at <http://www.vmware.com/resources/compatibility/search.php> and select **Search by Fault Tolerant Compatible Sets**.
- The configuration of the virtual machine must be valid for use with Fault Tolerance (for example, it must not contain any unsupported devices).

Secondary VM Placement

When your effort to turn on Fault Tolerance for a virtual machine passes the validation checks, the Secondary VM is created. The placement and immediate status of the Secondary VM depends upon whether the Primary VM was powered-on or powered-off when you turned on Fault Tolerance.

If the Primary VM is powered on:

- The entire state of the Primary VM is copied and the Secondary VM is created, placed on a separate compatible host, and powered on if it passes admission control.
- The Fault Tolerance Status displayed for the virtual machine is **Protected**.

If the Primary VM is powered off:

- The Secondary VM is immediately created and registered to a host in the cluster (it might be re-registered to a more appropriate host when it is powered on.)
- The Secondary VM is not powered on until after the Primary VM is powered on.
- The Fault Tolerance Status displayed for the virtual machine is **Not Protected, VM not Running**.
- When you attempt to power on the Primary VM after Fault Tolerance has been turned on, the additional validation checks listed above are performed.

After these checks are passed, the Primary and Secondary VMs are powered on and placed on separate, compatible hosts. The virtual machine's Fault Tolerance Status is tagged as **Protected**.

Turn On Fault Tolerance

You can turn on vSphere Fault Tolerance through the vSphere Client.

When Fault Tolerance is turned on, vCenter Server resets the virtual machine's memory limit and sets the memory reservation to the memory size of the virtual machine. While Fault Tolerance remains turned on, you cannot change the memory reservation, size, limit, number of vCPUs, or shares. You also cannot add or remove disks for the VM. When Fault Tolerance is turned off, any parameters that were changed are not reverted to their original values.

Connect vSphere Client to vCenter Server using an account with cluster administrator permissions.

Prerequisites

The option to turn on Fault Tolerance is unavailable (dimmed) if any of these conditions apply:

- The virtual machine resides on a host that does not have a license for the feature.
- The virtual machine resides on a host that is in maintenance mode or standby mode.
- The virtual machine is disconnected or orphaned (its .vmx file cannot be accessed).
- The user does not have permission to turn the feature on.

Procedure

- 1 In the vSphere Client, browse to the virtual machine for which you want to turn on Fault Tolerance.
- 2 Right-click the virtual machine and select **Fault Tolerance > Turn On Fault Tolerance**.
- 3 Click **Yes**.
- 4 Select a datastore on which to place the Secondary VM configuration files. Then click **Next**.
- 5 Select a host on which to place the Secondary VM. Then click **Next**.
- 6 Review your selections and then click **Finish**.

Results

The specified virtual machine is designated as a Primary VM, and a Secondary VM is established on another host. The Primary VM is now fault tolerant.

Note The VM datastores and memory are replicated during the FT Turn On process. This can take several minutes depending on the size of the replicated data. The VM state does not appear as protected until replication is complete.

Turn Off Fault Tolerance

Turning off vSphere Fault Tolerance deletes the secondary virtual machine, its configuration, and all history.

Use the **Turn Off Fault Tolerance** option if you do not plan to reenable the feature. Otherwise, use the **Suspend Fault Tolerance** option.

Note If the Secondary VM resides on a host that is in maintenance mode, disconnected, or not responding, you cannot use the **Turn Off Fault Tolerance** option. In this case, you should suspend and resume Fault Tolerance instead.

Procedure

- 1 In the vSphere Client, browse to the virtual machine for which you want to turn off Fault Tolerance.
- 2 Right-click the virtual machine and select **Fault Tolerance > Turn Off Fault Tolerance**.

- 3 Click **Yes**.

Results

Fault Tolerance is turned off for the selected virtual machine. The history and the secondary virtual machine for the selected virtual machine are deleted.

Note Fault Tolerance cannot be turned off when the secondary VM is in the process of being started. Since this involves syncing up the primary VM's full state to the secondary VM, this process may take longer than expected.

Suspend Fault Tolerance

Suspending vSphere Fault Tolerance for a virtual machine suspends its Fault Tolerance protection, but preserves the Secondary VM, its configuration, and all history. Use this option to resume Fault Tolerance protection in the future.

Procedure

- 1 In the vSphere Client, browse to the virtual machine for which you want to suspend Fault Tolerance.
- 2 Right-click the virtual machine and select **Fault Tolerance > Suspend Fault Tolerance**.
- 3 Click **Yes**.

Results

Fault Tolerance is suspended for the selected virtual machine. Any history and the Secondary VM for the selected virtual machine are preserved and will be used if the feature is resumed.

What to do next

After you suspend Fault Tolerance, to resume the feature select **Resume Fault Tolerance**.

Migrate Secondary

After vSphere Fault Tolerance is turned on for a Primary VM, you can migrate its associated Secondary VM.

Procedure

- 1 In the vSphere Client, browse to the Primary VM for which you want to migrate its Secondary VM.
- 2 Right-click the virtual machine and select **Fault Tolerance > Migrate Secondary**.
- 3 Complete the options in the Migrate dialog box and confirm the changes that you made.
- 4 Click **Finish** to apply the changes.

Results

The Secondary VM associated with the selected fault tolerant virtual machine is migrated to the specified host.

Test Failover

You can induce a failover situation for a selected Primary VM to test your Fault Tolerance protection.

This option is unavailable (dimmed) if the virtual machine is powered off.

Procedure

- 1 In the vSphere Client, browse to the Primary VM for which you want to test failover.
- 2 Right-click the virtual machine and select **Fault Tolerance > Test Failover**.
- 3 View details about the failover in the Task Console.

Results

This task induces failure of the Primary VM to ensure that the Secondary VM replaces it. A new Secondary VM is also started placing the Primary VM back in a Protected state.

Test Restart Secondary

You can induce the failure of a Secondary VM to test the Fault Tolerance protection provided for a selected Primary VM.

This option is unavailable (dimmed) if the virtual machine is powered off.

Procedure

- 1 In the vSphere Client, browse to the Primary VM for which you want to conduct the test.
- 2 Right-click the virtual machine and select **Fault Tolerance > Test Restart Secondary**.
- 3 View details about the test in the Task Console.

Results

This task results in the termination of the Secondary VM that provided Fault Tolerance protection for the selected Primary VM. A new Secondary VM is started, placing the Primary VM back in a Protected state.

Upgrade Hosts Used for Fault Tolerance

Use the following procedure to upgrade hosts used for Fault Tolerance.

Prerequisites

Verify that you have cluster administrator privileges.

Verify that you have sets of four or more ESXi hosts that are hosting fault tolerant virtual machines that are powered on. If the virtual machines are powered off, the Primary and Secondary VMs can be relocated to hosts with different builds.

Note This upgrade procedure is for a minimum four-node cluster. The same instructions can be followed for a smaller cluster, though the unprotected interval will be slightly longer.

Procedure

- 1 Using vMotion, migrate the fault tolerant virtual machines off of two hosts.
- 2 Upgrade the two evacuated hosts to the same ESXi build.
- 3 Suspend Fault Tolerance on the Primary VM.
- 4 Using vMotion, move the Primary VM for which Fault Tolerance has been suspended to one of the upgraded hosts.
- 5 Resume Fault Tolerance on the Primary VM that was moved.
- 6 Repeat [Step 1](#) to [Step 5](#) for as many fault tolerant virtual machine pairs as can be accommodated on the upgraded hosts.
- 7 Using vMotion, redistribute the fault tolerant virtual machines.

Results

All ESXi hosts in a cluster are upgraded.

Enable Fault Tolerance Encryption

You can encrypt Fault Tolerance log traffic.

vSphere Fault Tolerance performs frequent checks between a primary VM and secondary VM so that the secondary VM can quickly resume from the last successful checkpoint. The checkpoint contains the VM state that has been modified since the previous checkpoint. You can encrypt Fault Tolerance log traffic.

When you turn on Fault Tolerance, FT encryption is set to **Opportunistic** by default, which means it enables encryption only if both the primary and secondary host are capable of encryption. Follow this procedure if you need to change the FT encryption mode manually.

Prerequisites

FT encryption requires SMP-FT. Encryption on Legacy FT (Record-Replay FT) is not supported.

Procedure

- 1 Select the VM and choose **Edit Settings**.
- 2 Under **VM Options** select the **Encrypted FT** drop-down menu.

3 Choose one of the following options:

Option	Description
Disabled	Do not turn on encrypted Fault Tolerance logging.
Opportunistic	Turn on encryption only if both sides are capable. A Fault Tolerance VM is allowed to move to an ESXi host which does not support encrypted Fault Tolerance logging.
Required	Choose hosts for Fault Tolerance primary and secondary that both support encrypted FT logging.

Note While VM encryption is enabled, FT encryption mode is set to **Required** by default and cannot be modified.

When FT encryption mode is set to **Required**:

- When you turn on FT, only FT encryption supported hosts are listed for the placement of FT secondary.
- FT failover can only happen on the FT encryption supported hosts.

4 Click **OK**.

Best Practices for Fault Tolerance

To ensure optimal Fault Tolerance results, you should follow certain best practices.

The following recommendations for host and networking configuration can help improve the stability and performance of your cluster.

Host Configuration

Hosts running the Primary and Secondary VMs should operate at approximately the same processor frequencies, otherwise the Secondary VM might be restarted more frequently. Platform power management features that do not adjust based on workload (for example, power capping and enforced low frequency modes to save power) can cause processor frequencies to vary greatly. If Secondary VMs are being restarted on a regular basis, disable all power management modes on the hosts running fault tolerant virtual machines or ensure that all hosts are running in the same power management modes.

Host Networking Configuration

The following guidelines allow you to configure your host's networking to support Fault Tolerance with different combinations of traffic types (for example, NFS) and numbers of physical NICs.

- Distribute each NIC team over two physical switches ensuring L2 domain continuity for each VLAN between the two physical switches.

- Use deterministic teaming policies to ensure particular traffic types have an affinity to a particular NIC (active/standby) or set of NICs (for example, originating virtual port-id).
- Where active/standby policies are used, pair traffic types to minimize impact in a failover situation where both traffic types will share a vmnic.
- Where active/standby policies are used, configure all the active adapters for a particular traffic type (for example, FT Logging) to the same physical switch. This minimizes the number of network hops and lessens the possibility of oversubscribing the switch to switch links.

Note FT logging traffic between Primary and Secondary VMs is unencrypted and contains guest network and storage I/O data, as well as the memory contents of the guest operating system. This traffic can include sensitive data such as passwords in plaintext. To avoid such data being divulged, ensure that this network is secured, especially to avoid 'man-in-the-middle' attacks. For example, you could use a private network for FT logging traffic.

Homogeneous Clusters

vSphere Fault Tolerance can function in clusters with nonuniform hosts, but it works best in clusters with compatible nodes. When constructing your cluster, all hosts should have the following configuration:

- Common access to datastores used by the virtual machines.
- The same virtual machine network configuration.
- The same BIOS settings (power management and hyperthreading) for all hosts.

Run **Check Compliance** to identify incompatibilities and to correct them.

Performance

To increase the bandwidth available for the logging traffic between Primary and Secondary VMs use a 10Gbit NIC, and enable the use of jumbo frames.

You can select multiple NICs for the FT logging network. By selecting multiple NICs, you can take advantage of the bandwidth from multiple NICs even if all of the NICs are not dedicated to running FT.

Store ISOs on Shared Storage for Continuous Access

Store ISOs that are accessed by virtual machines with Fault Tolerance enabled on shared storage that is accessible to both instances of the fault tolerant virtual machine. If you use this configuration, the CD-ROM in the virtual machine continues operating normally, even when a failover occurs.

Avoid Network Partitions

A network partition occurs when a vSphere HA cluster has a management network failure that isolates some of the hosts from vCenter Server and from one another. See [Network Partitions](#) . When a partition occurs, Fault Tolerance protection might be degraded.

In a partitioned vSphere HA cluster using Fault Tolerance, the Primary VM (or its Secondary VM) could end up in a partition managed by a primary host that is not responsible for the virtual machine. When a failover is needed, a Secondary VM is restarted only if the Primary VM was in a partition managed by the primary host responsible for it.

To ensure that your management network is less likely to have a failure that leads to a network partition, follow the recommendations in [Best Practices for Networking](#).

Using vSAN Datastores

vSphere Fault Tolerance can use vSAN datastores, but you must observe the following restrictions:

- A mix of vSAN and other types of datastores is not supported for both Primary VMs and Secondary VMs.
- vSAN metro clusters are not supported with FT.

To increase performance and reliability when using FT with vSAN, the following conditions are also recommended.

- vSAN and FT should use separate networks.
- Keep Primary and Secondary VMs in separate vSAN fault domains.

Legacy Fault Tolerance

Legacy FT VMs can exist only on ESXi hosts that are running on vSphere versions earlier than 6.5.

ESXi hosts prior to version 6.5 supported vSphere Fault Tolerance based on a different technology. If you are using this form of Fault Tolerance and need to continue doing so, we recommend you reserve a vCenter 6.0 instance to manage the pool of pre-6.5 hosts required to run these VMs. vCenter 6.0 was the last version fully capable of managing legacy FT protected VMs. For more information on Legacy Fault Tolerance, see vSphere Availability 6.0 documentation.

Troubleshooting Fault Tolerant Virtual Machines

To maintain a high level of performance and stability for your fault tolerant virtual machines and also to minimize failover rates, you should be aware of certain troubleshooting issues.

The troubleshooting topics discussed focus on problems that you might encounter when using the vSphere Fault Tolerance feature on your virtual machines. The topics also describe how to resolve problems.

You can also see the VMware knowledge base article at <http://kb.vmware.com/kb/1033634> to help you troubleshoot Fault Tolerance. This article contains a list of error messages that you might encounter when you attempt to use the feature and, where applicable, advice on how to resolve each error.

Hardware Virtualization Not Enabled

You must enable Hardware Virtualization (HV) before you use vSphere Fault Tolerance.

Problem

When you attempt to power on a virtual machine with Fault Tolerance enabled, an error message might appear if you did not enable HV.

Cause

This error is often the result of HV not being available on the ESXi server on which you are attempting to power on the virtual machine. HV might not be available either because it is not supported by the ESXi server hardware or because HV is not enabled in the BIOS.

Solution

If the ESXi server hardware supports HV, but HV is not currently enabled, enable HV in the BIOS on that server. The process for enabling HV varies among BIOSes. See the documentation for your hosts' BIOSes for details on how to enable HV.

If the ESXi server hardware does not support HV, switch to hardware that uses processors that support Fault Tolerance.

Compatible Hosts Not Available for Secondary VM

If you power on a virtual machine with Fault Tolerance enabled and no compatible hosts are available for its Secondary VM, you might receive an error message.

Problem

You might encounter the following error message:

```
Secondary VM could not be powered on as there are no compatible hosts that can accommodate it.
```

Cause

This can occur for a variety of reasons including that there are no other hosts in the cluster, there are no other hosts with HV enabled, Hardware MMU Virtualization is not supported by host CPUs, data stores are inaccessible, there is no available capacity, or hosts are in maintenance mode.

Solution

If there are insufficient hosts, add more hosts to the cluster. If there are hosts in the cluster, ensure they support HV and that HV is enabled. The process for enabling HV varies among BIOSes. See the documentation for your hosts' BIOSes for details on how to enable HV. Check that hosts have sufficient capacity and that they are not in maintenance mode.

Secondary VM on Overcommitted Host Degrades Performance of Primary VM

If a Primary VM appears to be executing slowly, even though its host is lightly loaded and retains idle CPU time, check the host where the Secondary VM is running to see if it is heavily loaded.

Problem

When a Secondary VM resides on a host that is heavily loaded, the Secondary VM can affect the performance of the Primary VM.

Cause

A Secondary VM running on a host that is overcommitted (for example, with its CPU resources) might not get the same amount of resources as the Primary VM. When this occurs, the Primary VM must slow down to allow the Secondary VM to keep up, effectively reducing its execution speed to the slower speed of the Secondary VM.

Solution

If the Secondary VM is on an overcommitted host, you can move the VM to another location without resource contention problems. Or more specifically, do the following:

- For FT networking contention, use vMotion technology to move the Secondary VM to a host with fewer FT VMs contending on the FT network. Verify that the quality of the storage access to the VM is not asymmetric.
- For storage contention problems, turn FT off and on again. When you recreate the Secondary VM, change its datastore to a location with less resource contention and better performance potential.
- To resolve a CPU resources problem, set an explicit CPU reservation for the Primary VM at an MHz value sufficient to run its workload at the desired performance level. This reservation is applied to both the Primary and Secondary VMs, ensuring that both VMs can execute at a specified rate. For guidance in setting this reservation, view the performance graphs of the virtual machine (before Fault Tolerance was enabled) to see how many CPU resources it used under normal conditions.

Increased Network Latency Observed in FT Virtual Machines

If your FT network is not optimally configured, you might experience latency problems with the FT VMs.

Problem

FT VMs might see a variable increase in packet latency (on the order of milliseconds). Applications that demand very low network packet latency or jitter (for example, certain real-time applications) might see a degradation in performance.

Cause

Some increase in network latency is expected overhead for Fault Tolerance, but certain factors can add to this latency. For example, if the FT network is on a particularly high latency link, this latency is passed on to the applications. Also, if the FT network has insufficient bandwidth (fewer than 10 Gbps), greater latency might occur.

Solution

Verify that the FT network has sufficient bandwidth (10 Gbps or more) and uses a low latency link between the Primary VM and Secondary VM. These precautions do not eliminate network latency, but minimize its potential impact.

Some Hosts Are Overloaded with FT Virtual Machines

You might encounter performance problems if your cluster's hosts have an imbalanced distribution of FT VMs.

Problem

Some hosts in the cluster might become overloaded with FT VMs, while other hosts might have unused resources.

Cause

vSphere DRS does not load balance FT VMs (unless they are using legacy FT). This limitation might result in a cluster where hosts are unevenly distributed with FT VMs.

Solution

Manually rebalance the FT VMs across the cluster by using vSphere vMotion. Generally, the fewer FT VMs that are on a host, the better they perform, due to reduced contention for FT network bandwidth and CPU resources.

Losing Access to FT Metadata Datastore

Access to the Fault Tolerance metadata datastore is essential for the proper functioning of an FT VM. Loss of this access can cause a variety of problems.

Problem

These problems include the following:

- FT can terminate unexpectedly.
- If both the Primary VM and Secondary VM cannot access the metadata datastore, the VMs might fail unexpectedly. Typically, an unrelated failure that terminates FT must also occur when access to the FT metadata datastore is lost by both VMs. vSphere HA then tries to restart the Primary VM on a host with access to the metadata datastore.

- The VM might stop being recognized as an FT VM by vCenter Server. This failed recognition can allow unsupported operations such as taking snapshots to be performed on the VM and cause problematic behavior.

Cause

Lack of access to the Fault Tolerance metadata datastore can lead to the undesirable outcomes in the previous list.

Solution

When planning your FT deployment, place the metadata datastore on highly available storage. While FT is running, if you see that the access to the metadata datastore is lost on either the Primary VM or the Secondary VM, promptly address the storage problem before loss of access causes one of the previous problems. If a VM stops being recognized as an FT VM by vCenter Server, do not perform unsupported operations on the VM. Restore access to the metadata datastore. After access is restored for the FT VMs and the refresh period has ended, the VMs are recognizable.

Turning On vSphere FT for Powered-On VM Fails

If you try to turn on vSphere Fault Tolerance for a powered-on VM, this operation can fail.

Problem

When you select **Turn On Fault Tolerance** for a powered-on VM, the operation fails and you see an `Unknown error` message.

Cause

This operation can fail if the host that the VM is running on has insufficient memory resources to provide fault tolerant protection. vSphere Fault Tolerance automatically tries to allocate a full memory reservation on the host for the VM. Overhead memory is required for fault tolerant VMs and can sometimes expand to 1 to 2 GB. If the powered-on VM is running on a host that has insufficient memory resources to accommodate the full reservation plus the overhead memory, trying to turn on Fault Tolerance fails. Subsequently, the `Unknown error` message is returned.

Solution

Choose from these solutions:

- Free up memory resources on the host to accommodate the VM's memory reservation and the added overhead.
- Move the VM to a host with ample free memory resources and try again.

FT Virtual Machines not Placed or Evacuated by vSphere DRS

FT virtual machines in a cluster that is enabled with vSphere DRS do not function correctly if Enhanced vMotion Compatibility (EVC) is currently disabled.

Problem

Because EVC is a prerequisite for using DRS with FT VMs, DRS does not place or evacuate them if EVC has been disabled (even if it is later reenabled).

Cause

When EVC is disabled on a DRS cluster, a VM override that disables DRS on an FT VM might be added. Even if EVC is later reenabled, this override is not canceled.

Solution

If DRS does not place or evacuate FT VMs in the cluster, check the VMs for a VM override that is disabling DRS. If you find one, remove the override that is disabling DRS.

Note For more information on how to edit or delete VM overrides, see *vSphere Resource Management*.

Fault Tolerant Virtual Machine Failovers

A Primary or Secondary VM can fail over even though its ESXi host has not crashed. In such cases, virtual machine execution is not interrupted, but redundancy is temporarily lost. To avoid this type of failover, be aware of some of the situations when it can occur and take steps to avoid them.

Partial Hardware Failure Related to Storage

This problem can arise when access to storage is slow or down for one of the hosts. When this occurs there are many storage errors listed in the VMkernel log. To resolve this problem you must address your storage-related problems.

Partial Hardware Failure Related to Network

If the logging NIC is not functioning or connections to other hosts through that NIC are down, this can trigger a fault tolerant virtual machine to be failed over so that redundancy can be reestablished. To avoid this problem, dedicate a separate NIC each for vMotion and FT logging traffic and perform vMotion migrations only when the virtual machines are less active.

Insufficient Bandwidth on the Logging NIC Network

This can happen because of too many fault tolerant virtual machines being on a host. To resolve this problem, more broadly distribute pairs of fault tolerant virtual machines across different hosts.

Use a 10-Gbit logging network for FT and verify that the network is low latency.

vMotion Failures Due to Virtual Machine Activity Level

If the vMotion migration of a fault tolerant virtual machine fails, the virtual machine might need to be failed over. Usually, this occurs when the virtual machine is too active for the migration to be completed with only minimal disruption to the activity. To avoid this problem, perform vMotion migrations only when the virtual machines are less active.

Too Much Activity on VMFS Volume Can Lead to Virtual Machine Failovers

When a number of file system locking operations, virtual machine power ons, power offs, or vMotion migrations occur on a single VMFS volume, this can trigger fault tolerant virtual machines to be failed over. A symptom that this might be occurring is receiving many warnings about SCSI reservations in the VMkernel log. To resolve this problem, reduce the number of file system operations or ensure that the fault tolerant virtual machine is on a VMFS volume that does not have an abundance of other virtual machines that are regularly being powered on, powered off, or migrated using vMotion.

Lack of File System Space Prevents Secondary VM Startup

Check whether or not your `/(root)` or `/vmfs/datasource` file systems have available space. These file systems can become full for many reasons, and a lack of space might prevent you from being able to start a new Secondary VM.

vCenter High Availability

4

vCenter High Availability (vCenter HA) protects vCenter Server against host and hardware failures. The active-passive architecture of the solution can also help you reduce downtime significantly when you patch vCenter Server.

After some network configuration, you create a three-node cluster that contains Active, Passive, and Witness nodes. Different configuration paths are available. What you select depends on your existing configuration.

Procedure

1 Plan the vCenter HA Deployment

Before you can configure vCenter HA, you have to consider several factors. A deployment with components that use different versions of vSphere requires different considerations than a deployment that includes only vSphere 7.0 components. Resource and software requirements and the networking setup must also be considered carefully.

2 Configure the Network

Regardless of the deployment option and inventory hierarchy that you select, you have to set up your network before you can start configuration. To set the foundation for the vCenter HA network, you add a port group to each ESXi host.

3 Configure vCenter HA With the vSphere Client

When you use the vSphere Client, the **Set Up vCenter HA** wizard creates and configures a second network adapter on the vCenter Server, clones the Active node, and configures the vCenter HA network.

4 Manage the vCenter HA Configuration

After you configure your vCenter HA cluster, you can perform management tasks. These tasks include certificate replacement, replacement of SSH keys, and SNMP setup. You can also edit the cluster configuration to disable or enable vCenter HA, enter maintenance mode, and remove the cluster configuration.

5 Troubleshoot Your vCenter HA Environment

In case of problems you can troubleshoot your environment. The task you need to perform depends on the failure symptoms. For additional troubleshooting information, see the VMware Knowledge Base system.

6 Patching a vCenter High Availability Environment

You can patch a vCenter Server which is in a vCenter High Availability cluster by using the `software-packages` utility available in the vCenter Server shell.

Plan the vCenter HA Deployment

Before you can configure vCenter HA, you have to consider several factors. A deployment with components that use different versions of vSphere requires different considerations than a deployment that includes only vSphere 7.0 components. Resource and software requirements and the networking setup must also be considered carefully.

vCenter Architecture Overview

A vCenter HA cluster consists of three vCenter Server instances. The first instance, initially used as the Active node, is cloned twice to a Passive node and to a Witness node. Together, the three nodes provide an active-passive failover solution.

Deploying each of the nodes on a different ESXi instance protects against hardware failure. Adding the three ESXi hosts to a DRS cluster can further protect your environment.

When vCenter HA configuration is complete, only the Active node has an active management interface (public IP). The three nodes communicate over a private network called vCenter HA network that is set up as part of configuration. The Active node is continuously replicating data to the Passive node.

Figure 4-1. vCenter Three-Node Cluster

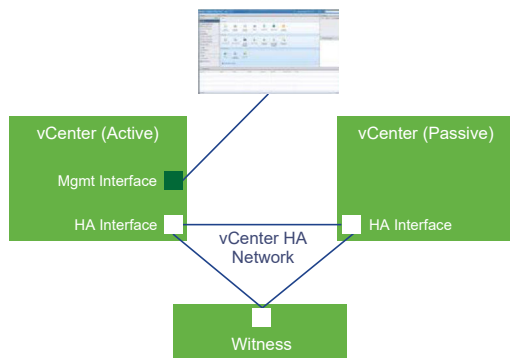

All three nodes are necessary for the functioning of this feature. Compare the node responsibilities.

Table 4-1. vCenter HA Nodes

Node	Description
Active	<ul style="list-style-type: none"> ■ Runs the active vCenter Server instance ■ Uses a public IP address for the management interface ■ Uses the vCenter HA network for replication of data to the Passive node. ■ Uses the vCenter HA network to communicate with the Witness node.
Passive	<ul style="list-style-type: none"> ■ Is initially a clone of the Active node ■ Constantly receives updates from and synchronizes state with the Active node over the vCenter HA network ■ Automatically takes over the role of the Active node if a failure occurs
Witness	<ul style="list-style-type: none"> ■ Is a lightweight clone of the Active node ■ Provides a quorum to protect against a split-brain situations

vCenter HA Hardware and Software Requirements

Before you set up vCenter HA, ensure that you have sufficient memory, CPU, and datastore resources, and ensure that you are using versions of vCenter Server and ESXi that support vCenter HA.

Your environment must meet the following requirements.

Table 4-2. vCenter HA Requirements

Component	Requirements
ESXi	<ul style="list-style-type: none"> ■ ESXi 6.0 or later is required. ■ A minimum of three ESXi hosts is strongly recommended. Each vCenter HA node can then run on a different host for better protection.
Management vCenter Server (if used)	<p>Your environment can include a management vCenter Server system, or you can set up your vCenter Server to manage the ESXi host on which it runs (self-managed vCenter Server)</p> <ul style="list-style-type: none"> ■ vCenter Server 6.0 or later is required.
vCenter Server	<ul style="list-style-type: none"> ■ vCenter Server 6.5 or later is required. ■ Deployment size Small (4 CPU and 16GB RAM) or bigger is required to meet the RTO. Do not use Tiny in production environments. ■ vCenter HA is supported and tested with VMFS, NFS, and vSAN datastores. ■ Ensure you have enough disk space to collect and store support bundles for all three nodes on the Active node. See Collecting Support Bundles for a vCenter HA Node.
Network connectivity	<ul style="list-style-type: none"> ■ vCenter HA network latency between Active, Passive, and Witness nodes must be less than 10 ms. ■ The vCenter HA network must be on a different subnet than the management network.
Licensing required for vCenter HA	<ul style="list-style-type: none"> ■ vCenter HA requires a single vCenter Server license. ■ vCenter HA requires a Standard license.

Configuration Workflow Overview in the vSphere Client

You can use the **Set Up vCenter HA** wizard in the vSphere Client to configure the Passive and Witness nodes. The **Set Up vCenter HA** wizard automatically creates the Passive and Witness nodes as part of vCenter HA configuration. With the manual option, you are responsible for manually cloning the Active node to create the Passive and Witness nodes.

Automatic Configuration with the vSphere Client

You must meet the following requirements to perform automatic configuration.

- The vCenter Server that will become the Active node is managing its own ESXi host and its own virtual machine. This configuration is sometimes called a self-managed vCenter Server.

If you meet the requirements the automatic workflow is as follows.

- 1 The user deploys the first vCenter Server, which will become the Active node.
- 2 The user adds a second network (port group) for vCenter HA traffic on each ESXi host.
- 3 The user starts the vCenter HA configuration and supplies the IP addresses, the target ESXi host or cluster, and the datastore for each clone.
- 4 The system clones the Active node and creates a Passive node with precisely the same settings, including the same host name.
- 5 The system clones the Active node again and creates a more light-weight Witness node.
- 6 The system sets up the vCenter HA network on which the three nodes communicate, for example, by exchanging heartbeats and other information.

Manual Configuration with the vSphere Client

If you want more control over your deployment, you can perform a manual configuration. With this option, you are responsible for cloning the Active node yourself as part of vCenter HA setup. If you select this option and remove the vCenter HA configuration later, you are responsible for deleting the nodes that you created.

For the manual option, the workflow is as follows.

- 1 The user deploys the first vCenter Server, which will become the Active node.
- 2 The user adds a second network (port group) for vCenter HA traffic on each ESXi host.
- 3 The user must add a second network adapter (NIC) to the Active node if the credentials of the Active management vCenter Server are unknown.
- 4 The user logs in to the vCenter Server (Active node) with the vSphere Client.
- 5 The user starts the vCenter HA configuration, selects the checkbox to manually configure and supplies IP address and subnet information for the Passive and Witness nodes. Optionally, the user can override the failover management IP addresses.
- 6 The user logs in to the management vCenter Server and creates two clones of the vCenter Server (Active node).

- 7 The system sets up the vCenter HA network on which the three nodes exchange heartbeats and replication information.
- 8 The vCenter Server is protected by vCenter HA.

See [Configure vCenter HA With the vSphere Client](#) for details.

Configure the Network

Regardless of the deployment option and inventory hierarchy that you select, you have to set up your network before you can start configuration. To set the foundation for the vCenter HA network, you add a port group to each ESXi host.

After configuration is complete, the vCenter HA cluster has two networks, the management network on the first virtual NIC and the vCenter HA network on the second virtual NIC.

Management network

The management network serves client requests (public IP). The management network IP addresses must be static.

vCenter HA network

The vCenter HA network connects the Active, Passive, and Witness nodes and replicates the server state. It also monitors heartbeats.

- The vCenter HA network IP addresses for the Active, Passive, and Witness nodes must be static.
- The vCenter HA network must be on a different subnet than the management network. The three nodes can be on the same subnet or on different subnets.
- Network latency between the Active, Passive, and Witness nodes must be less than 10 milliseconds.
- You must not add a default gateway entry for the cluster network.

Prerequisites

- The vCenter Server that later becomes the Active node, is deployed.
- You can access and have privileges to modify that vCenter Server and the ESXi host on which it runs.
- During network setup, you need static IP addresses for the management network. The management and cluster network addresses must be IPv4 or IPv6. They cannot be mixed mode IP addresses.

Procedure

- 1 Log in to the management vCenter Server and find the ESXi host on which the Active node is running.

- 2 Add a port group to the ESXi host.

This port group can be on an existing virtual switch or, for improved network isolation, you can create a new virtual switch. It must be different from the management network.

- 3 If your environment includes the recommended three ESXi hosts, add the port group to each of the hosts.

Configure vCenter HA With the vSphere Client

When you use the vSphere Client, the **Set Up vCenter HA** wizard creates and configures a second network adapter on the vCenter Server, clones the Active node, and configures the vCenter HA network.

Prerequisites

- Deploy vCenter Server that you want to use as the initial Active node.
 - The vCenter Server must have a static IP address.
 - SSH must be enabled on the vCenter Server.
- Verify that your environment meets the following requirements.
 - The vCenter Server that will become the Active node is managing its own ESXi host and its own virtual machine. This configuration is sometimes called a self-managed vCenter Server.
- Set up the infrastructure for the vCenter HA network. See [Configure the Network](#).
- Determine which static IP addresses to use for the two vCenter Server nodes that will become the Passive node and Witness node.

Procedure

- 1 Log in to the Active node with the vSphere Client.
- 2 Select the vCenter Server object in the inventory and select the **Configure** tab.
- 3 Select **vCenter HA** under settings.
- 4 Click on the **Set Up vCenter HA** button to start the setup wizard.
 - If the vCenter server is self-managed, the **Resource settings** page is displayed. Proceed to step 7.
 - If your vCenter server is managed by another vCenter server in the same SSO domain, proceed to step 7.
 - If your vCenter server is managed by another vCenter server in a different SSO domain, input the location and credential details of that management vCenter server.

- 5 Click **Management vCenter Server credentials**. Specify the Management vCenter server FQDN or IP address, Single Sign-On user name and password and click **Next**.

If you do not have the Single Sign-On administrator credentials, select the second bullet and click **Next**.

- 6 You may see a **Certificate warning** displayed. Review the SHA1 thumbprint and select **Yes** to continue.
- 7 In the **Resource settings** section, first select the vCenter HA network for the active node from the drop-down menu.
- 8 Click on the checkbox if you want to automatically create clones for Passive and Witness nodes.

Note If you do not select the checkbox, you must manually create clones for Passive and Witness nodes after you click **Finish**.

- 9 For the Passive node, click **Edit**.
 - a Specify a unique name and target location.
 - b Select the destination compute resource for the operation.
 - c Select the datastore in which to store the configuration and disk files.
 - d Select virtual machine Management (NIC 0) and vCenter HA (NIC 1) networks.

If there are issues with your selections, errors or compatibility warnings are displayed.
 - e Review your selections and click **Finish**.

- 10 For the Witness node, click **Edit**.
 - a Specify a unique name and target location.
 - b Select the destination compute resource for the operation.
 - c Select the datastore in which to store the configuration and disk files.
 - d Select vCenter HA (NIC 1) network.

If there are issues with your selections, errors or compatibility warnings are displayed.
 - e Review your selections and click **Finish**.

- 11 Click **Next**.

- 12 In the **IP settings** section, select the IP version from the drop-down menu.

- 13 Enter the IPv4 address (NIC 1) and Subnet mask or prefix length information for the Active, Passive and Witness nodes.

You can Edit management network settings for the Passive Node. Customizing these settings are optional. By default, the management network settings of the Active node are applied.

- 14 Click **Finish**.

Results

The Passive and Witness nodes are created. When **Set Up vCenter HA** is complete, vCenter Server has high availability protection. After vCenter HA is enabled, you can click **Edit** to enter Maintenance Mode, Enable or Disable vCenter HA. There are separate buttons to remove vCenter HA or initiate vCenter HA failover.

What to do next

See [Manage the vCenter HA Configuration](#) for a list of cluster management tasks.

For a brief overview of enhancements in the vSphere Client when working with vCenter HA, see:



Enhancements to Working with vCenter HA in the vSphere Client
(http://link.brightcove.com/services/player/bcpid2296383276001?bctid=ref:video_vsphere67_HA)

Manage the vCenter HA Configuration

After you configure your vCenter HA cluster, you can perform management tasks. These tasks include certificate replacement, replacement of SSH keys, and SNMP setup. You can also edit the cluster configuration to disable or enable vCenter HA, enter maintenance mode, and remove the cluster configuration.

■ [Set Up SNMP Traps](#)

You can set up Simple Network Management Protocol (SNMP) traps to receive SNMP notifications for your vCenter HA cluster.

■ [Set Up Your Environment to Use Custom Certificates](#)

The machine SSL certificate on each node is used for cluster management communication and for encryption of replication traffic. If you want to use custom certificates, you have to remove the vCenter HA configuration, delete the Passive and Witness nodes, provision the Active node with the custom certificate, and reconfigure the cluster.

■ [Manage vCenter HA SSH Keys](#)

vCenter HA uses SSH keys for password-less authentication between the Active, Passive, and Witness nodes. The authentication is used for heartbeat exchange and file and data replication. To replace the SSH keys in the nodes of a vCenter HA cluster, you disable the cluster, generate new SSH keys on the Active node, transfer the keys to the passive node, and enable the cluster.

■ [Initiate a vCenter HA Failover](#)

You can manually initiate a failover and have the Passive node become the Active node.

■ [Edit the vCenter HA Cluster Configuration](#)

When you edit the vCenter HA cluster configuration, you can disable or enable the cluster, place the cluster in maintenance mode, or remove the cluster.

- [Perform Backup and Restore Operations](#)

For additional security, you can back up the Active node in the vCenter HA cluster. You can then restore the node in case of catastrophic failure.

- [Remove a vCenter HA Configuration](#)

You can remove a vCenter HA configuration from the vSphere Client.

- [Reboot All vCenter HA Nodes](#)

If you have to shut down and reboot all nodes in the cluster, you must follow a specific shutdown order to prevent the Passive node from assuming the role of Active node.

- [Change the Server Environment](#)

When you deploy a vCenter Server, you select an environment. For vCenter HA, Small, Medium, Large, and X-Large are supported for production environments. If you need more space and want to change the environment, you have to delete the Passive node virtual machine before you change the configuration.

- [Collecting Support Bundles for a vCenter HA Node](#)

Collecting a support bundle from all the nodes in a vCenter HA cluster helps with troubleshooting.

Set Up SNMP Traps

You can set up Simple Network Management Protocol (SNMP) traps to receive SNMP notifications for your vCenter HA cluster.

The traps default to SNMP version 1.

Set up SNMP traps for the Active node and the Passive node. You tell the agent where to send related traps, by adding a target entry to the `snmpd` configuration.

Procedure

- 1 Log in to the Active node by using the Virtual Machine Console or SSH.
- 2 Run the `vicfg-snmp` command, for example:

```
vicfg-snmp -t 10.160.1.1@1166/public
```

In this example, `10.160.1.1` is the client listening address, `1166` is the client listening port, and `public` is the community string.

- 3 Enable the SNMP agent (`snmpd`) by running the following command.

```
vicfg-snmp -e
```

What to do next

You also might find these commands useful.

- To view the complete help for the command, run `vicfg-snmp -h`.

- To disable the SNMP agent, run `vicfg-snmp -D`.
- To show the SNMP agent's configuration, run `vicfg-snmp -s`.
- To reset the configuration to the default, run `vicfg-snmp -r`.

Set Up Your Environment to Use Custom Certificates

The machine SSL certificate on each node is used for cluster management communication and for encryption of replication traffic. If you want to use custom certificates, you have to remove the vCenter HA configuration, delete the Passive and Witness nodes, provision the Active node with the custom certificate, and reconfigure the cluster.

If possible, replace certificates in the vCenter Server that will become the Active node before you clone the node.

Procedure

- 1 Edit the cluster configuration and select **Remove**.
- 2 Delete the Passive node and the Witness node.
- 3 On the Active node, which is now a standalone vCenter Server, replace the machine SSL Certificate with a custom certificate.
- 4 Reconfigure the cluster.

Manage vCenter HA SSH Keys

vCenter HA uses SSH keys for password-less authentication between the Active, Passive, and Witness nodes. The authentication is used for heartbeat exchange and file and data replication. To replace the SSH keys in the nodes of a vCenter HA cluster, you disable the cluster, generate new SSH keys on the Active node, transfer the keys to the passive node, and enable the cluster.

Procedure

- 1 Edit the cluster and change the mode to **Disabled**.
- 2 Log in to the Active node by using the Virtual Machine Console or SSH.
- 3 Enable the bash shell.

```
bash
```

- 4 Run the following command to generate new SSH keys on the Active node.

```
/usr/lib/vmware-vcha/scripts/resetSshKeys.py
```

- 5 Use SCP to copy the keys to the Passive node and Witness node.

```
scp /vcha/.ssh/*
```

- 6 Edit the cluster configuration and set the vCenter HA cluster to **Enabled**.

Initiate a vCenter HA Failover

You can manually initiate a failover and have the Passive node become the Active node.

A vCenter HA cluster supports two types of failover.

Automatic failover

The Passive node attempts to take over the active role in case of an Active node failure.

Manual failover

The user can force a Passive node to take over the active role by using the Initiate Failover action.

Initiate a manual failover for troubleshooting and testing.

Procedure

- 1 Log in to the Active node vCenter Server with the vSphere Client and click **Configure** for the vCenter Server where you need to initiate failover.
- 2 Under **Settings** select **vCenter HA** and click **Initiate Failover**.
- 3 Click **Yes** to start the failover.

A dialog offers you the option to force a failover without synchronization. In most cases, performing synchronization first is best.
- 4 After the failover, you can verify that the Passive node has the role of the Active node in the vSphere Client.

Edit the vCenter HA Cluster Configuration

When you edit the vCenter HA cluster configuration, you can disable or enable the cluster, place the cluster in maintenance mode, or remove the cluster.

The operating mode of a vCenter Server controls the failover capabilities and state replication in a vCenter HA cluster.

A vCenter HA cluster can operate in one of the following modes.

Table 4-3. vCenter HA Cluster Modes of Operation

Mode	Automatic Failover	Manual Failover	Replication	
Enabled	Yes	Yes	Yes	This default mode of operation protects the vCenter Server from hardware and software failures by performing automatic failover.
Maintenance	No	Yes	Yes	Used for some maintenance tasks. For other tasks, you have to disable vCenter HA.
Disabled	No	No	No	If the Passive or Witness nodes are lost or recovering from a failure, a vCenter HA configuration can be disabled. The Active node continues as a standalone vCenter Server.

Note If the cluster is operating in either Maintenance or Disabled mode, an Active node can continue serving client requests even if the Passive and Witness nodes are lost or unreachable.

Prerequisites

Verify that the vCenter HA cluster is deployed and contains the Active, Passive, and Witness nodes.

Procedure

- 1 Log in to the Active node vCenter Server with the vSphere Client and click **Configure**.
- 2 Under **Settings** select **vCenter HA** and click **Edit**.
- 3 Select one of the options.

Option	Result
Enable vCenter HA	Enables replication between the Active and Passive nodes. If the cluster is in a healthy state, your Active node is protected by automatic failover from the Passive node.
Maintenance Mode	In maintenance mode, replication still occurs between the Active and Passive nodes. However, automatic failover is disabled.
Disable vCenter HA	Disables replication and failover. Keeps the configuration of the cluster. You can later enable vCenter HA again.
Remove vCenter HA cluster	Removes the cluster. Replication and failover no longer are provided. The Active node continues to operate as a standalone vCenter Server. See Remove a vCenter HA Configuration for details.

- 4 Click OK.

Perform Backup and Restore Operations

For additional security, you can back up the Active node in the vCenter HA cluster. You can then restore the node in case of catastrophic failure.

Note Remove the cluster configuration before you restore the Active node. Results are unpredictable if you restore the Active node and the Passive node is still running or other cluster configuration is still in place.

Prerequisites

Verify the interoperability of vCenter HA and the backup and restore solution. One solution is vCenter Server file-based restore.

Procedure

- 1 Back up the Active node.
Do not back up the Passive node and Witness node.
- 2 Before you restore the cluster, power off and delete all vCenter HA nodes.
- 3 Restore the Active node.
The Active node is restored as a standalone vCenter Server.
- 4 Reconfigure the vCenter HA.

Remove a vCenter HA Configuration

You can remove a vCenter HA configuration from the vSphere Client.

Procedure

- 1 Log in to the Active node vCenter Server and click **Configure**.
- 2 Under **Settings** select **vCenter HA** and click **Remove VCHA**.
 - The vCenter HA cluster's configuration is removed from the Active, Passive, and Witness nodes.
 - You can choose to delete the Passive and Witness nodes.
 - The Active node continues to run as a standalone vCenter Server.
 - You cannot reuse the Passive and Witness nodes in a new vCenter HA configuration.
 - If you performed a manual configuration, or if the Passive and Witness nodes are not discoverable, you must delete these nodes explicitly.
 - Even if the second virtual NIC was added by the configuration process, the removal process does not remove the virtual NIC.

Reboot All vCenter HA Nodes

If you have to shut down and reboot all nodes in the cluster, you must follow a specific shutdown order to prevent the Passive node from assuming the role of Active node.

Procedure

- 1 Shut down the nodes in this order.
 - Passive node
 - Active node
 - Witness node
- 2 Restart each node.

You can restart nodes in any order.
- 3 Verify that all nodes join the cluster successfully, and that the previous Active node resumes that role.

Change the Server Environment

When you deploy a vCenter Server, you select an environment. For vCenter HA, Small, Medium, Large, and X-Large are supported for production environments. If you need more space and want to change the environment, you have to delete the Passive node virtual machine before you change the configuration.

Procedure

- 1 Log in to the Active node with the vSphere Client, edit the cluster configuration, and select **Disable**.
- 2 Delete the Passive node virtual machine.
- 3 Change the vCenter Server configuration for the Active node, for example, from a Small environment to a Medium environment.
- 4 Reconfigure vCenter HA.

Collecting Support Bundles for a vCenter HA Node

Collecting a support bundle from all the nodes in a vCenter HA cluster helps with troubleshooting.

When you collect a support bundle from the Active node in a vCenter HA cluster, the system proceeds as follows.

- Collects support bundle information from the Active node itself.
- Collects support bundles from Passive and Witness nodes and places them in the `commands` directory on the Active node support bundle.

Note The collection of support bundles from the Passive and Witness nodes is a best effort and happens if the nodes are reachable.

Troubleshoot Your vCenter HA Environment

In case of problems you can troubleshoot your environment. The task you need to perform depends on the failure symptoms. For additional troubleshooting information, see the VMware Knowledge Base system.

- [vCenter HA Clone Operation Fails During Deployment](#)

If the vCenter HA configuration process does not create the clones successfully, you have to resolve that cloning error.

- [Redeploy the Passive or Witness node](#)

If the passive or witness node fails and vCenter HA cluster was configured using the automatic cloning method, you can redeploy it in the **vCenter HA Settings** page.

- [vCenter HA Deployment Fails with an Error](#)

Deployment failures can be caused by configuration issues, especially problems with the networking setup.

- [Troubleshooting a Degraded vCenter HA Cluster](#)

For a vCenter HA cluster to be healthy, each of the Active, Passive, and Witness nodes must be fully operational and be reachable over the vCenter HA cluster network. If any of the nodes fails, the cluster is considered to be in a degraded state.

- [Recovering from Isolated vCenter HA Nodes](#)

If all nodes in a vCenter HA cluster cannot communicate with each other, the Active node stops serving client requests.

- [Resolving Failover Failures](#)

When a Passive node does not become the Active node during a failover, you can force the Passive node to become the Active node.

- [VMware vCenter® HA Alarms and Events](#)

If a vCenter HA cluster is in a degraded state, alarms and events show errors.

vCenter HA Clone Operation Fails During Deployment

If the vCenter HA configuration process does not create the clones successfully, you have to resolve that cloning error.

Problem

Clone operation fails.

Note Cloning a Passive or Witness VM for a VCHA deployment to the same NFS 3.1 datastore as the source Active node VM fails. You must use NFS4 or clone the Passive and Witness VMs to a datastore different from the Active VM.

Cause

Look for the clone exception. It might indicate one of the following problems.

- You have a DRS-enabled cluster, but do not have three hosts.
- The host or database connection is lost.
- Not enough disk space.
- Other **Clone Virtual Machine** errors

Solution

- 1 Resolve the error that caused the problem.
- 2 Remove the cluster and start configuration again.

Redeploy the Passive or Witness node

If the passive or witness node fails and vCenter HA cluster was configured using the automatic cloning method, you can redeploy it in the **vCenter HA Settings** page.

Procedure

- 1 Log in to the Active node with the vSphere Client.
- 2 Select the vCenter Server object in the inventory and select the **Configure** tab.
- 3 Select **vCenter HA** under **Settings**.
- 4 Click on the **REDEPLOY** button next to the node to start the Redeploy wizard.
- 5
 - If your vCenter server is managed by another vCenter server in the same SSO domain, proceed to step 6.
 - If your vCenter server is managed by another vCenter server in a different SSO domain, input the location and credential details of that management vCenter server. Enter the **Management vCenter Server FQDN or IP address** and **Single Sign-On** credentials.
- 6 Specify a unique name and target location.
- 7 Select the destination compute resource for the operation.
- 8 Select the datastore in which to store the configuration and disk files.
- 9 Configure the virtual machine networks.
 - If you are redeploying the Passive node, select virtual machine Management (NIC 0) and vCenter HA (NIC 1) networks.
 - If you are redeploying the Witness node, select vCenter HA (NIC 1) network.

If there are issues with your selections, errors or compatibility warnings are displayed.
- 10 Review your selections and click **Finish** to redeploy the node.

vCenter HA Deployment Fails with an Error

Deployment failures can be caused by configuration issues, especially problems with the networking setup.

Problem

You start a vCenter HA cluster configuration, and it fails with an error. The error might show the cause of the problem, for example, you might see an SSH Connection Failed message.

Solution

If deployment fails, take steps to resolve the network issues.

- 1 Verify that the Passive and Witness nodes can be reached from the Active node.
- 2 Verify that routing between the nodes is set up correctly.
- 3 Check network latency.

Troubleshooting a Degraded vCenter HA Cluster

For a vCenter HA cluster to be healthy, each of the Active, Passive, and Witness nodes must be fully operational and be reachable over the vCenter HA cluster network. If any of the nodes fails, the cluster is considered to be in a degraded state.

Problem

If the cluster is in a degraded state, failover cannot occur. For information about failure scenarios while the cluster is in a degraded state, see [Resolving Failover Failures](#).

Cause

The cluster can be in a degraded state for a number of reasons.

One of the nodes fails

- If the Active node fails, a failover of the Active node to the Passive node occurs automatically. After the failover, the Passive node becomes the Active node.

At this point, the cluster is in a degraded state because the original Active node is unavailable.

After the failed node is repaired or comes online, it becomes the new Passive node and the cluster returns to a healthy state after the Active and Passive nodes synchronize.

- If the Passive node fails, the Active node continues to function, but no failover is possible and the cluster is in a degraded state.

If the Passive node is repaired or comes online, it automatically rejoins the cluster and the cluster state is healthy after the Active and Passive nodes synchronize.

- If the Witness node fails, the Active node continues to function and replication between Active and Passive node continues, but no failover can occur.

If the Witness node is repaired or comes online, it automatically rejoins the cluster and the cluster state is healthy.

Database replication fails

If replication fails between the Active and Passive nodes, the cluster is considered degraded. The Active node continues to synchronize with the Passive node. If it succeeds, the cluster returns to a healthy state. This state can result from network bandwidth problems or other resource shortages.

Configuration file replication issues

If configuration files are not properly replicated between the Active and Passive nodes, the cluster is in a degraded state. The Active node continues to attempt synchronization with the Passive node. This state can result from network bandwidth problems or other resource shortages.

Solution

How you recover depends on the cause of the degraded cluster state. If the cluster is in a degraded state, events, alarms, and SNMP traps show errors.

If one of the nodes is down, check for hardware failure or network isolation. Check whether the failed node is powered on.

In case of replication failures, check if the vCenter HA network has sufficient bandwidth and ensure network latency is 10 ms or less.

Recovering from Isolated vCenter HA Nodes

If all nodes in a vCenter HA cluster cannot communicate with each other, the Active node stops serving client requests.

Problem

Node isolation is a network connectivity problem.

Solution

- 1 Attempt to resolve the connectivity problem. If you can restore connectivity, isolated nodes rejoin the cluster automatically and the Active node starts serving client requests.
- 2 If you cannot resolve the connectivity problem, you have to log in to Active node's console directly.
 - a Power off and delete the Passive node and the Witness node virtual machines.
 - b Log in to the Active node by using SSH or through the Virtual Machine Console.
 - c To enable the Bash shell, enter **shell** at the `appliance$` prompt.

- d Run the following command to remove the vCenter HA configuration.

```
vcha-destroy -f
```

- e Reboot the Active node.

The Active node is now a standalone vCenter Server.

- f Perform vCenter HA cluster configuration again.

Resolving Failover Failures

When a Passive node does not become the Active node during a failover, you can force the Passive node to become the Active node.

Problem

The Passive node fails while trying to assume the role of the Active node.

Cause

A vCenter HA failover might not succeed for these reasons.

- The Witness node becomes unavailable while the Passive node is trying to assume the role of the Active node.
- An server state synchronization issue between the nodes exists.

Solution

You recover from this issue as follows.

- 1 If the Active node recovers from the failure, it becomes the Active node again.
- 2 If the Witness node recovers from the failure, follow these steps.
 - a Log in to the Passive node through the Virtual Machine Console.
 - b To enable the Bash shell, enter **shell** at the `appliancesh` prompt.
 - c Run the following command.

```
vcha-reset-primary
```

- d Reboot the Passive node.
- 3 If both Active node and Witness node cannot recover, you can force the Passive node to become a standalone vCenter Server.
 - a Delete the Active node and Witness node virtual machines.
 - b Log in to the Passive node through the Virtual Machine Console.
 - c To enable the Bash shell, enter **shell** at the `appliancesh` prompt.

- d Run the following command.

```
vcha-destroy
```

- e Reboot the Passive node.

VMware vCenter® HA Alarms and Events

If a vCenter HA cluster is in a degraded state, alarms and events show errors.

Problem

Table 4-4. The following events will raise VCHA health alarm in vpxd:

Event Name	Event Description	Event Type	Category
vCenter HA cluster state is currently healthy	vCenter HA cluster state is currently healthy	com.vmware.vcha.cluster.state.healthy	info
vCenter HA cluster state is currently degraded	vCenter HA cluster state is currently degraded	com.vmware.vcha.cluster.state.degraded	warning
vCenter HA cluster state is currently isolated	vCenter HA cluster state is currently isolated	com.vmware.vcha.cluster.state.isolated	error
vCenter HA cluster is destroyed	vCenter HA cluster is destroyed	com.vmware.vcha.cluster.state.destroyed	info

Table 4-5. The following events will raise PSC HA health alarm in vpxd:

Event Name	Event Description	Event Type	Category
PSC HA state is currently healthy	PSC HA state is currently healthy	com.vmware.vcha.psc.health.healthy	info
PSC HA state is currently degraded	PSC HA state is currently degraded	com.vmware.vcha.psc.health.degraded	info
PSC HA is not monitored after vCenter HA cluster is destroyed	PSC HA state is not being monitored	com.vmware.vcha.psc.health.unknown	info

Table 4-6. Cluster Status Related Events

Event Name	Event Description	Event Type	Category
Node {nodeName} joined back to the cluster	One node joined back to the cluster	com.vmware.vcha.node.joined	info
Node {nodeName} left the cluster	One node left the cluster	com.vmware.vcha.node.left	warning
Failover succeeded	Failover succeeded	com.vmware.vcha.failover.succeeded	info
Failover cannot proceed when cluster is in disabled mode	Failover cannot proceed when cluster is in disabled mode	com.vmware.vcha.failover.failed.disabled.mode	warning

Table 4-6. Cluster Status Related Events (continued)

Event Name	Event Description	Event Type	Category
Failover cannot proceed when cluster does not have all three nodes connected	Failover cannot proceed when cluster does not have all three nodes connected	com.vmware.vcha.failover.failed.node.lost	warning
Failover cannot proceed when vPostgres on Passive node is not ready to takeover	Failover cannot proceed when Passive node is not ready to takeover	com.vmware.vcha.failover.failed.passive.not.ready	warning
vCenter HA cluster mode changed to {clusterMode}	vCenter HA cluster mode changed	com.vmware.vcha.cluster.mode.changed	info

Table 4-7. Database replication-related events

Event Name	Event Description	Event Type	Category
Database replication mode changed to {newState}	Database replication state changed: sync, async or no replication	com.vmware.vcha.DB.replication.state.changed	info

Table 4-8. File replication-related events

Event Name	Event Description	Event Type	Category
Appliance {fileProviderType} is {state}	Appliance File replication state changed	com.vmware.vcha.file.replication.state.changed	info

Patching a vCenter High Availability Environment

You can patch a vCenter Server which is in a vCenter High Availability cluster by using the **software-packages** utility available in the vCenter Server shell.

For more information, see *Patch a vCenter High Availability Environment* in *vSphere Upgrade*.